

The House of a Thousand Sounds

THE **G H W** CO.

Drummers' Instruments

1401 North Nappanee St.

Phone 264-4022 (219)

ELKHART, INDIANA 46514

GEO. H. WAY — Owner



ffff with the dynamics
of Lightning crashes

pppp
with the
whisper of
falling leaves



AVEDIS ZILDJIAN CYMBALS
The Supreme Quality of Percussion Sounds

... CYMBALS ARE THE "CROWNING GLORY" OF EVERY DRUMMER'S OUTFIT. THAT IS WHY SUCH GREAT CARE IS EXERCISED IN MAKING SELECTIONS OF SIZES, WEIGHTS AND SOUNDS. AND THAT IS ALSO WHY THE GREAT MAJORITY (AND WE REPEAT, — THE GREAT MAJORITY) OF PROFESSIONAL, SCHOOL AND COLLEGE DRUMMERS AND BANDMASTERS CHOOSE AVEDIS ZILDJIAN BRAND ABOVE ALL OTHERS. WE SPECIALIZE IN MAKING CAREFUL SELECTIONS. PLEASE DESCRIBE USE INTENDED. WE SUPPLY CYMBALS THRU THE MUSIC STORES FOR PARTICULAR DRUMMERS IN EVERY STATE.



8"	\$10.00 ★
10"	17.00 ★
12"	27.00 ★
13"	32.00 ★
14"	36.00 ★
15"	40.00 ★
16"	45.00 ★
17"	50.00 ★
18"	55.00 ★
19"	60.00 ★
20"	65.00 ★
22"	77.50 ★
24"	90.00 ★

PLEASE
SPECIFY
THICKNESS

"ZILCO" CYMBALS
MADE BY THE AVEDIS ZILDJIAN CO. U.S.A.

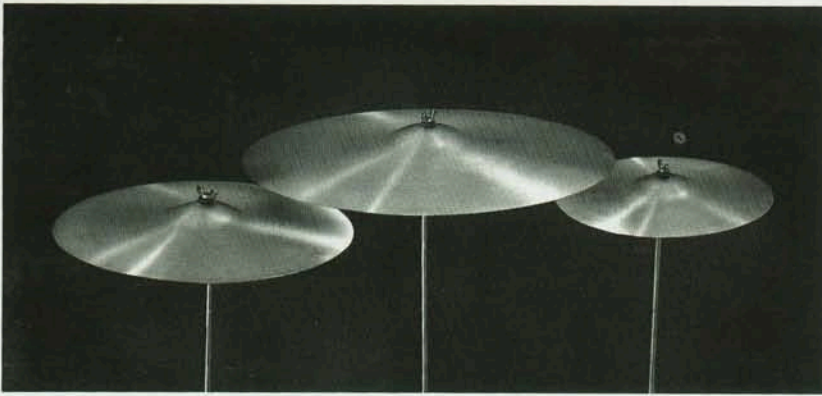

WHEN ORDERING PLEASE SPECIFY SIZE — WEIGHT — AND USE INTENDED — EXTRA THIN — THIN — MEDIUM THIN — MEDIUM — MEDIUM HEAVY AND HEAVY. ZILCO CYMBALS ARE NOT GUARANTEED AGAINST BREAKAGE.

10"	\$13.00★
12"	21.00★
14"	27.00★
16"	34.50★
18"	42.00★
20"	50.00★
22"	60.00★
24"	70.00★

THESE FINE QUALITY CYMBALS ARE MADE BY AZCO LTD., THE NEW CANADIAN FACTORY OF AVEDIS ZILDJIAN. THEY ARE MADE IN THE SAME TRADITION AND UNDER THE SAME SUPERVISION AS WORLD FAMOUS AVEDIS ZILDJIANS. TO A GREAT DEGREE THE SAME MATERIALS AND WORKMANSHIP ARE APPLIED. ZILCO'S BRILLIANT TONE QUALITY, QUICK RESPONSE AND RESONANCE OFFER UNUSUALLY GOOD VALUE TO THE DRUMMER OR ORGANIZATION WITH A MODEST CYMBAL BUDGET.

Pasha Cymbals

TURKISH TYPE — Imported

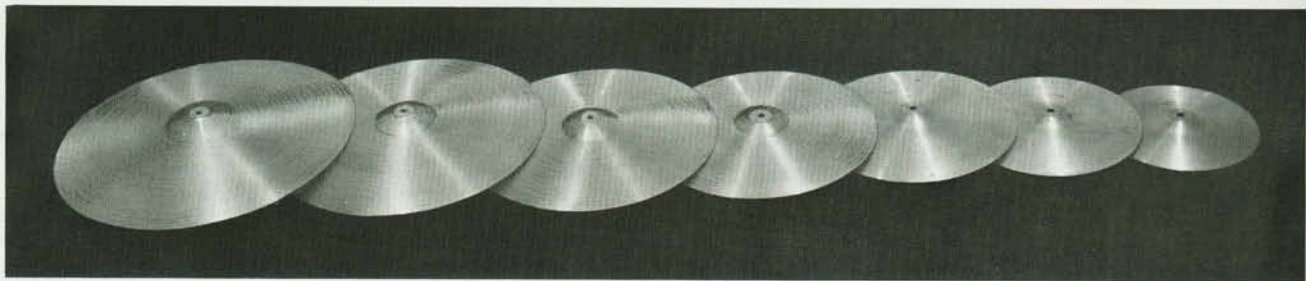

ACCLAIMED BY MANY PROMINENT DRUMMERS AND BANDMASTERS AS THE VERY FINEST TURKISH TYPE IMPORTED CYMBALS ON THE MARKET, WITH BRILLIANT AND RESONANT TONES ESPECIALLY SUITABLE FOR MODERN ORCHESTRA USE. CYMBALS CANNOT BE GUARANTEED PERFECT IN SIZE OR WEIGHT OR AGAINST BREAKAGE.

THIN		MEDIUM		HEAVY	
10" — EXTRA THIN	\$ 9.75	12" — MEDIUM	\$13.50	12" — HEAVY ONLY	\$16.50
11" — EXTRA THIN	11.50	13" — MEDIUM	18.50	13" — HEAVY ONLY	22.00
12" — EXTRA THIN	13.50	14" — MEDIUM	21.00	14" — HEAVY ONLY	25.00
13" — EXTRA THIN	18.50	15" — MEDIUM	23.00	15" — HEAVY ONLY	27.50
14" — EXTRA THIN	21.00	16" — MEDIUM	25.00	16" — HEAVY ONLY	31.75
15" — THIN	23.00	18" — MEDIUM	36.50		
16" — THIN	25.00	20" — MEDIUM	45.00		
18" — THIN	36.50	22" — MEDIUM	63.00		
20" — THIN	45.00				

SIZZLE CYMBALS

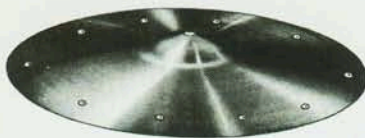

We will install rivets on Zildjian — Zilco — or Pasha cymbals free of charge. State number of rivets desired. Most drummers prefer six or eight.

- FELT
CYMBAL
WASHER
- RUBBER
CYMBAL
TUBE
- LEATHER
CYMBAL
WASHER
- HI-HAT
WING
NUT



1642 .. 16¢ 1643 .. 12¢ 1644 .. 08¢ 1646 .. 12¢

FINGER CYMBALS



Highly polished brass alloy. High pitch sounds. 2 1/8" diameter.

220 — SET OF 4

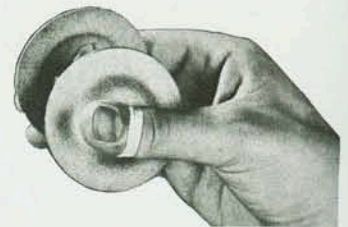

Cast Avedis Zildjian metal. Have piercing ring. For exotic dancers who desire the true Near-East sound. Specify high or low pitch sound.

No. F

SET — 2 PAIRS

CYMBAL POUCH



STRONG VINYL PLASTIC WITH ZIPPER AND SHOULDER STRAP

14" — 15" — 16" — 17" — 18"

19" — 20" — 21" — 22"

CYMBAL STICK



Very good for crashes and sustained "roars". Has a medium hard solid felt head.

3811

**ADJUSTO
HI-HAT**
1729-C...\$22.00



**HOLLYWOOD
HI-HAT**
502-C...\$19.50



**FLUSH BASE
CYMBAL STAND**
1725-C...\$9.90

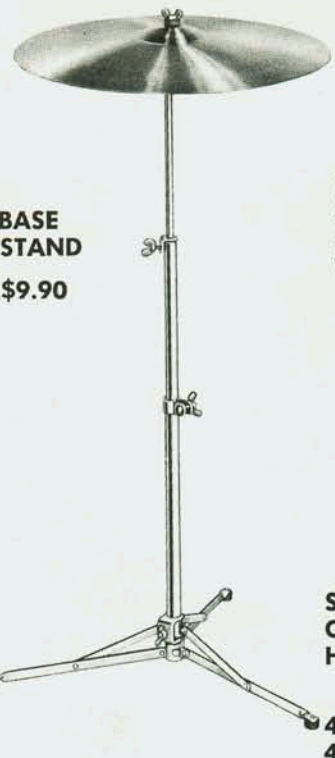

**DISAPPEARING
SHELL MOUNT
CYMBAL HOLDER
WITH TILTER**
1704 - Chrome
\$6.00



**STAY-TITE
CYMBAL HOLDER
HOOP MOUNT**
Chrome
4125 - 12" .. \$5.50
4126 - 15" .. 5.95
4127 - 18" .. 6.25



**ROGERS
CYMBAL
TILTER**
An All-
Direction
Tilter Holds
At All
Angles.
320
\$5.00



**DUPLEX
CYMBAL
TILTER**
Ratchet
Type. Holds
Fast In All
Positions.
3824
\$1.50



**WALBERG
CYMBAL
TILTER**
Pressed
Steel
Parts. All
Positions.
1666-C
\$2.30



**WALBERG
CYMBAL
CLUTCH**
Cone Grip
Cannot
Slip.
1463
\$1.80



**ROGERS
HI-HAT
CLUTCH**
Very Efficient
Will Not
Vibrate
Loose.
4404
\$3.00

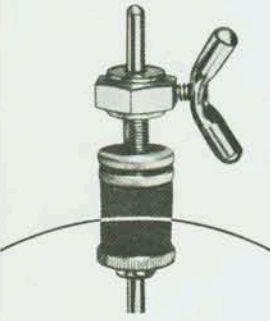

"COMFORTWAY" CYMBAL STRAPS AND PADS

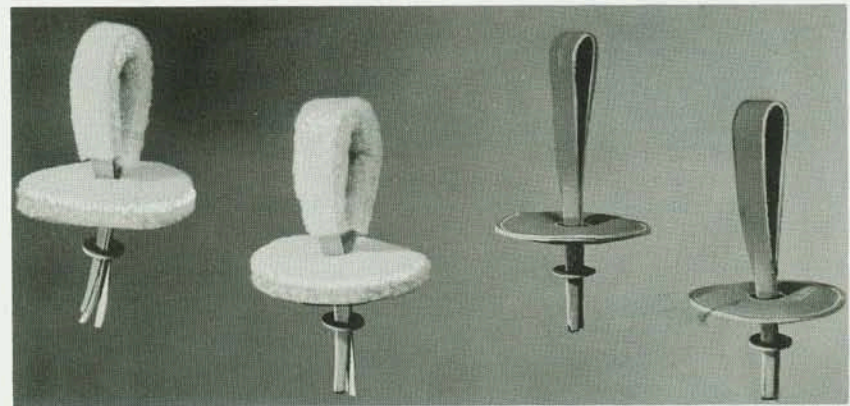

WOOD CYMBAL HANDLES
249 - Pair
\$2.25

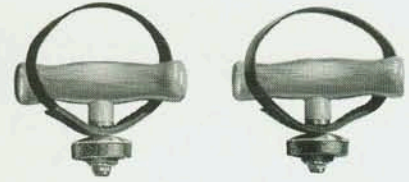

LAMB'S WOOL COVERED	SOLE GRAIN LEATHER
1054 - Straps - Pair\$3.20	1051 - Straps - Pair\$1.80
1056 - Pads - Pair 4.80	1052 - Pads - Pair 2.20
1057 - Straps & Pads - Pr. 8.00	1053 - Straps & Pads 4.00
Washers Included.	1058 - Washers Only - Pair 14¢

Packaged In Plastic Bags

**TELESCOPIC
CYMBAL
HOLDER**

Shell
Mount



3617
\$6.75
With
Tilter

**ROGERS
"ROCKET"
PEDAL**

398
\$29.50



**ROGERS
"JET"
PEDAL**

399
\$24.50



**DUPLEX
HEYN
PEDAL**

125
\$19.50



PEDAL BEATER BALLS AND RODS — FOR ALL SOUNDS



SOLID CORK

Solid Sound
All-Around Work
4597 \$2.20



LAMB'S WOOL

Soft Boom Sound
Concert Work
4431 \$2.75



SOLID FELT

Medium Sound
Most Used
4420 \$2.75



SOLID WOOD

Rock and Roll
and Bombs
4422 \$2.75



SOLID FELT

The "Thumper"
Low-Down Sound
"S"-Square \$3.50



**EVERGRIP
SPURS**

Chrome

710 — Pair \$5.50

**ROCKING CYMBAL
CUP**



3197 \$1.00

**BASS DRUM MUFFLER
With Pressure Adjustment**



4439 — Chrome \$5.90

**INTERNAL SNARE DRUM
AND TOM-TOM MUFFLER**



1448 \$2.50

**REGULATION SPURS
Hoop Mount**



1542 — Nickel Only - Pr. ...\$5.50

**RUBBER
PRACTICE TIPS**



Gum Rubber "Hoods"
Fit Over Stick Tips
For Individual or
Class Practice.

1756 — Pair \$0.30

**RUBBER
TIPS**



1627 1628

1627 — For Hi-Hat and
Drum Stands — each 16¢

1628 — For Spurs and
Anchors — each 16¢

SLEIGH BELLS ON HANDLES

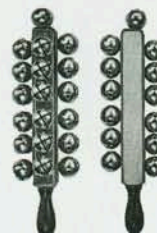

567 — 13 Bells \$ 6.75

568 — 25 Bells 10.50

4

**DISAPPEARING SPURS
SHELLMOUNT — CHROME**

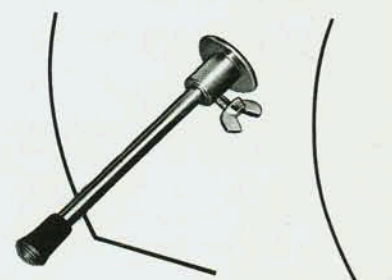

1705-C — Pair \$5.50

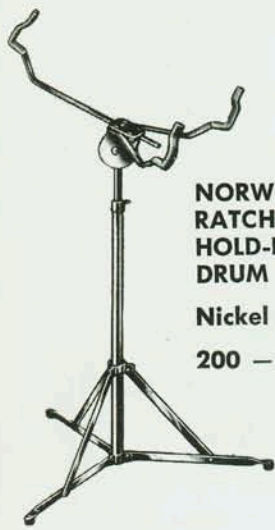

**NORWOOD
RATCHET
HOLD-FAST
DRUM STAND**
Nickel Only
200 — \$9.90



**MARVEL
WALBERG
FLUSH BASE
DRUM STAND**
Chrome
1716-C — \$10.80



**"BUCK ROGERS"
FLUSH BASE
DRUM STAND**
Chrome
1718-C — \$19.75



**POPULAR
FLUSH BASE
DRUM STAND**
Chrome
3830 — \$9.75



**WALBERG
THRONE**
Chrome
864-C \$18.75



**DEWEY
THRONE
Piano Stool
Adjustment**
Chrome
8201
\$27.00



**ANGULAR
THRONE**
Chrome
3833
\$17.50



**ROGERS
THRONE**
Chrome
4200
\$39.50

**WALBERG CONSOLETTA
TOM-TOM HOLDER
BASS DRUM — SHELLMOUNT**

Chrome
1435-C \$12.75



LITTLE GIANT SNARE STRAINER

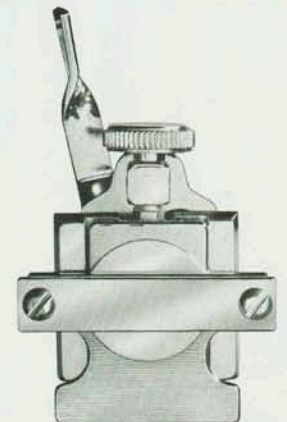

A Precision Die Cast
Model. Fits Most Drums

393 — Chrome \$7.90

**BASS DRUM ANCHOR
HOOP MOUNT**

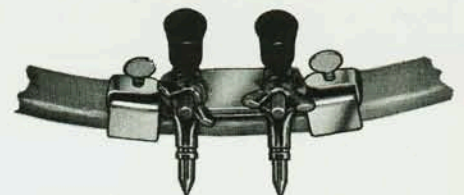

Double Clamps — Reversible Spurs
1601-C — Chrome \$5.50

the **SOUNDS**
of **DRUMS**
and
WHAT TO DO ABOUT THEM
by
GEO. H. WAY
ELKHART, INDIANA
presented by
ROBERT C. BEALS, President
EVANS PRODUCTS, Inc.
DODGE CITY, KANSAS
makers of
EVANS
All Whitten
DRUM HEADS
The best with the
"Plastic" — *long*

24
PAGE
BOOKLET
FREE

FACTS
NOT FOUND
ELSEWHERE

IT DOES NOT
TELL HOW
TO PLAY
DRUMS —
IT DOES
TELL HOW
TO MAKE
DRUMS PLAY

CONTENTS

How The Sound Is Made — What Is The Correct Sound? The Drummers Touch — Degree And Evenness Of Tension — Relative Tension — The "Ring" — The "Choke" — The Periphery — The Function Of The Snare Bed — Plastic Head Wrinkles — Togetherness In Sounds — Drums Without Snare Beds — Historical And Present-Day Facts — The Bass Drum — Tympani Head Notes — Plastic vs. Calf.

ROGERS TOM-TOM LEGS



Set of 3
Chrome

4416 \$9.50



THE "FEEL" AND BALANCE OF DRUM STICKS CANNOT BE DETERMINED BY LOOKING AT PHOTOGRAPHS. THEY MUST BE TRIED IN PERSON TO FIND WHAT BEST SUITS THE INDIVIDUAL. WE INVITE YOU TO PLAY A FEW "LICKS" WITH "PRO-MARKS" ON A DRUM OR PRACTICE PAD. TRY OUT SEVERAL DIFFERENT MODELS. YOU WILL ENJOY A NEW EXPERIENCE IN PLAYING SATISFACTION THAT YOU NEVER THOUGHT POSSIBLE. HERE ARE NEW DESIGNS FAR SUPERIOR TO THE "OLD TIMERS" AND FAR BETTER FOR ALL TYPES OF PLAYING - JAZZ - DANCE - CONCERT BAND - SYMPHONY OR PARADE. THEIR CLEAN SHAPES WITH HARD NO CHIP TIPS - ROUNDED BUTTS & BEAUTIFUL FINISH PROVE "PRO-MARKS" TO BE THE HIGHEST QUALITY STICKS EVER MADE.

All Sticks Packaged In Plastic Bags

All Sticks Packaged In Plastic Bags

STICKS WITH WOOD TIPS \$1.50 Per Pair
 STICKS WITH NYLON TIPS \$1.95 Per Pair

★ STARS SHOW MODELS AVAILABLE IN NYLON TIPS

- | | |
|-------------|-------------------------------------|
| G — 15" | TINY MITE Extra Light Weight |
| 9A — 15" | ★ PEE WEE Light Weight — jazz |
| 7A — 15½" | ★ Light Weight — jazz |
| JM — 15½" | ★ Approximately J.M. shape — dance |
| BR-GK — 16" | ★ Approximately B.R. and G.K. shape |
| C — 15⅞" | General purpose — medium weight |
| 7D — 15" | ★ Approximately M.L. shape — jazz |
| 8D — 15½" | ★ Approximately L.B. shape — jazz |
| 5A — 16⅛" | ★ Light Weight — concert — combo |
| JH — 16" | Approx. J.M. shape — solo — jazz |
| A — 16" | Like old 1A model — general — jazz |
| 7 — 15½" | ★ Approximately B.D. shape — jazz |
| 3D — 14⅞" | Approximately S.P. shape — jazz |
| 2D — 15¼" | General purpose — concert B. + O. |
| 5B — 15¾" | ★ Concert — medium — general |
| 2B — 15⅞" | Concert heavy — light parade |
| 1S — 16⅞" | Medium school — parade |
| 2S — 17" | Heavy parade — military |
| 3S — 16⅞" | Extra heavy parade — military |
| RN — 16" | Rock Nocker — rock 'n roll |

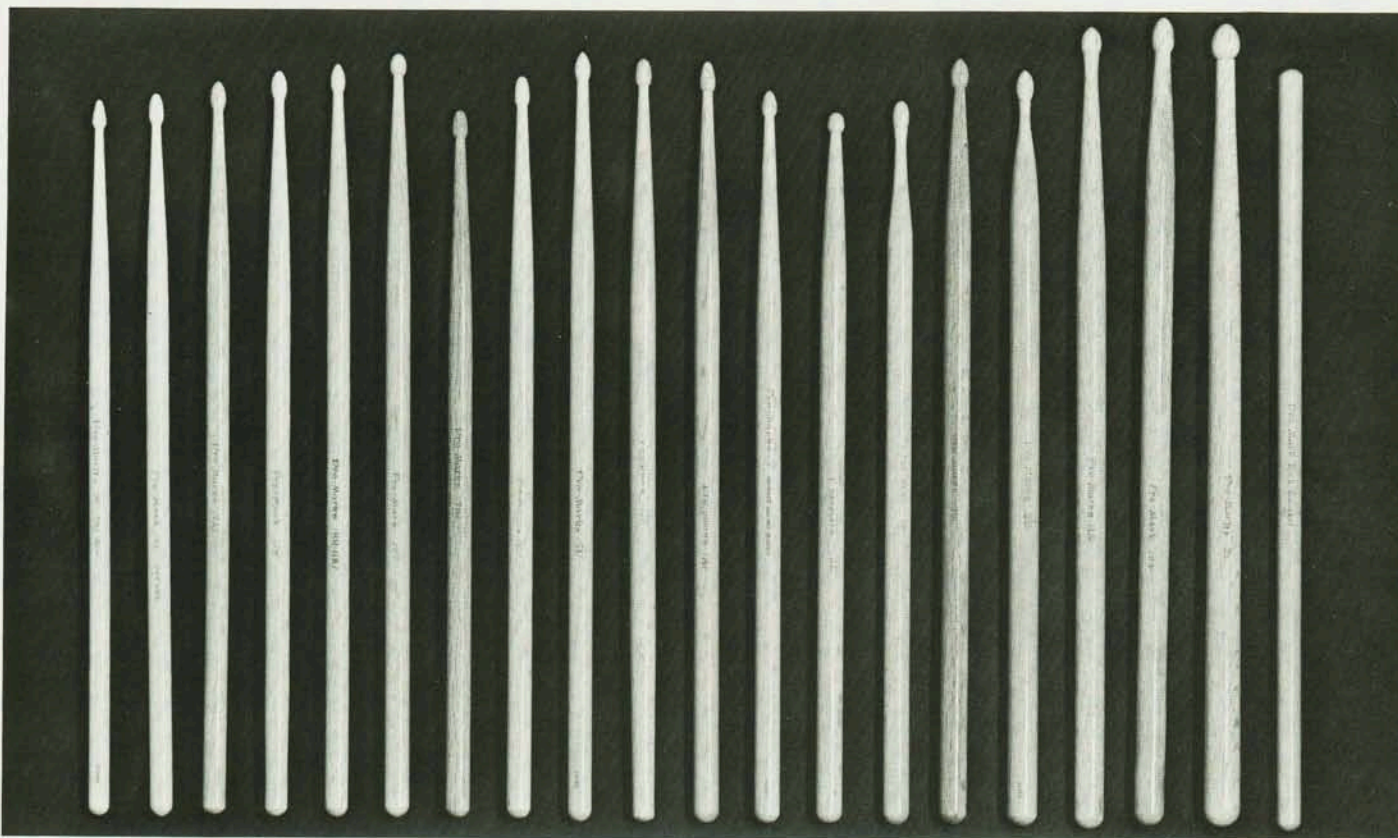

G 9A 7A JM BR-GK C 7D 8D 5A JH A 7 3D 2D 5B 2B 1S 2S 3S RN
 ★

STARS INDICATE MODELS AVAILABLE WITH NYLON TIPS

REGAL TIP DRUM STICKS

THE ORIGINAL NYLON TIP DRUM STICKS
REGAL TIP STICKS ARE MADE IN NYLON TIPS ONLY



SILHOUETTE ..	15"	Extra Light — Thin
COMBO	16"	Light — Thin
JAZZ	16"	Light — Thin
JAKE HANNA	16"	Medium Thin
3A	15½"	Medium Thin
5A	16"	Medium
6A	15"	Heavy Dance
7A	15"	Medium
JC	16"	Light Dance
2B	16"	Medium Heavy
5B	16"	Medium General Use

**\$1.95
PER PAIR**

ABOUT NYLON TIPS

IT IS NO EXAGGERATION TO SAY THAT THE INVENTION OF NYLON TIPS HAS BEEN ONE OF THE OUTSTANDING CONTRIBUTIONS TO BOTH PLAYING SATISFACTION AND MODERN RHYTHM SOUNDS.

SIL. COM. JAZZ HANNA 3A 5A 6A 7A J.C. 2B 5B
ABOVE MODELS MADE IN NYLON TIPS ONLY

STANDARD DRUM KEY AND HOLDER



1275
40¢

1277
80¢

G H W

HIGH GRADE SOLID NYLON TIPS GIVE STRONG PING. MORE DURABLE THAN WOOD TIPS. STICK HICKORY. CABINET FINISHED. EACH PAIR IN POLY BAGS.

★ Stars Show Models In Nylon Tips

T — 15¾" —	★	Extra Light Weight
1A — 16¾" —	★	Extra Light Weight
2A — 16" —		Light Weight
3A — 15½" —		Medium Weight
5A — 16" —	★	Medium Weight
6A — 15" —	★	Light Weight
7A — 15¼" —	★	Light Weight
9A — 14¾" —	★	Light Weight
1B — 16¼" —		Medium Weight
2B — 15¾" —	★	Med. Heavy Weight
5B — 16" —	★	Medium Weight
1S — 16¾" —		Med. Heavy Weight
2S — 16¾" —		Heavy Parade
3S — 16¾" —		Extra Heavy Parade

STICKS WITH WOOD TIPS \$1.40 pair

STICKS WITH NYLON TIPS \$1.95 pair



SELECTED HARDWHITE STRAIGHT GRAIN ALABAMA HICKORY IN STANDARD SHAPES — LACQUER FINISH — PACKAGED IN POLY BAGS.

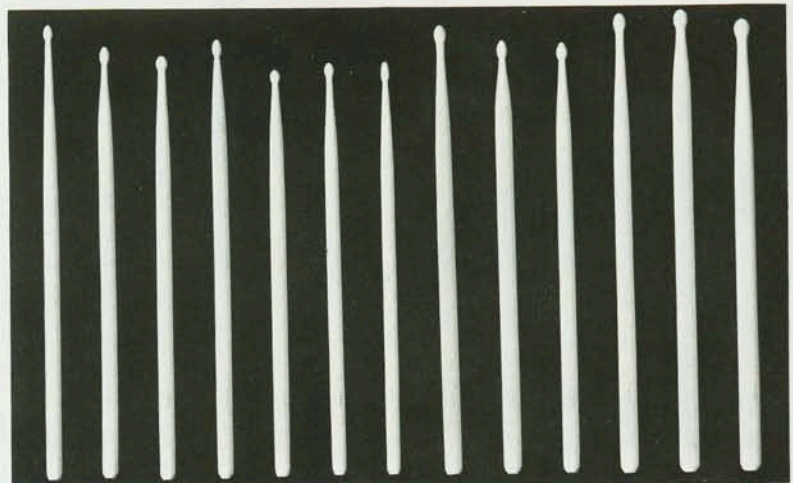

1A 2A 3A 5A 6A 7A 9A 1B 2B 5B 1S 2S 3S
★ ★ ★ ★ ★ ★ ★ ★ ★

STARS INDICATE MODELS AVAILABLE WITH NYLON TIPS



COW BELLS

Measurements Include Handles

COPPER

0-7 ³ / ₄ "	\$3.10
1-6 ⁷ / ₈ "	2.70
2-5 ³ / ₄ "	2.30
3-5 ¹ / ₈ "	2.00

CHROME

0-C-7 ³ / ₄ "	\$5.10
1-C-6 ⁷ / ₈ "	4.70
2-C-5 ³ / ₄ "	4.30
3-C-5 ¹ / ₈ "	4.00

POST COW BELL HOLDER



4656 -C	\$3.95
3096 -C - "U" Clamp50

STICK AND BRUSH TRAY



For Hi-Hat or Floor Cymbal Stand
288 - Chrome \$13.50*

FINGER CASTANETS



Mounted For Full Control

507	\$5.80
-----	-------	--------

WOOD RATTLE



CLAMPS TO
BASS DRUM
HOOP

560	\$6.50
-----	-------	--------

BASS DRUM ANCHOR HOOP MOUNT

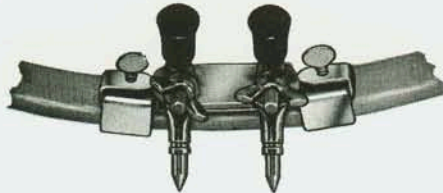

Double Clamps - Reversible Spurs

1601-C - Chrome	\$5.50
-----------------	-------	--------

WOOD BLOCK HOLDER



3462-C	\$1.50
--------	-------	--------

WOOD BLOCK HOLDER



3827-C	\$2.00
--------	-------	--------

WOOD BLOCK



1531	\$2.80
------	-------	--------

COMBINATION HOLDER



3828-C	\$3.00
--------	-------	--------

TAMBOURINE, 2 Rows Jingles



4732 - 10" - 17 PR. JINGLES	\$12.00
-----------------------------	-------	---------

TAMBOURINE, 1 Row Jingles



4722 - 10" - 9 PR. JINGLES	\$10.00
4721 - 8" - 6 PR. JINGLES	7.50
4720 - 7" - 5 PR. JINGLES	6.50

CASTANETS



506 - 2 PAIR ON HANDLE	\$3.90
505 - 1 PAIR ON HANDLE	2.90
500 - 2 PAIR FOR FINGERS	2.00

SLAP STICK



ROCK MAPLE WITH SPRING - LOUD	
116	\$4.50

BIRD WHISTLES

WARBLER - LARGE	
56	\$3.00
CANARY - SMALL	
59	\$2.25



ACME SIREN WHISTLE



27 - MADE IN ENGLAND	\$5.40
----------------------	-------	--------

SLIDE (SONG) WHISTLE



427	\$4.50
-----	-------	--------

TACKED HEADS — Large Bongos



Non Tunable — 7½" and 6½" Dia.
Mexican — Two-Tone Natural Wood.

107 \$9.50

TACKED HEADS—Medium Bongos



Non Tunable — 5¼" and 5" Dia.
Mexican — Two-Tone Natural Wood.

107-A \$8.50

LARGE MEXICAN MARACAS



1201 \$4.00

MEDIUM MEXICAN MARACAS



1203 \$3.50

MEXICAN HARDWOOD CLAVES



106 — Professional Size \$2.50

**DOUBLE TOM-TOM HOLDER
for Bass Drum Shell Mount**

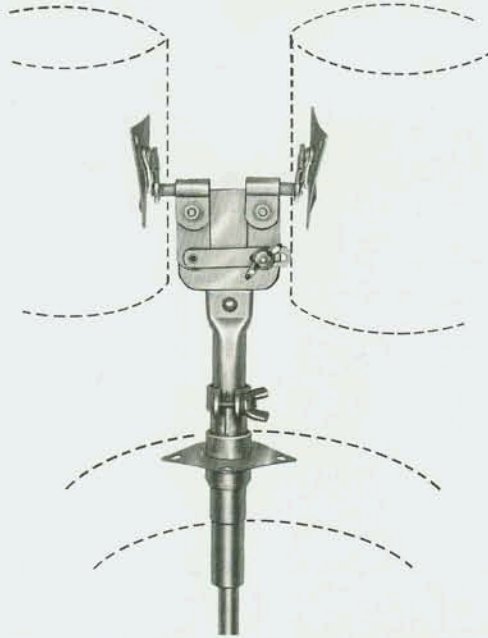

Great Strength — Adjustable — Rigid
4020 — Chrome \$19.90

BAND CYMBAL HOLDER

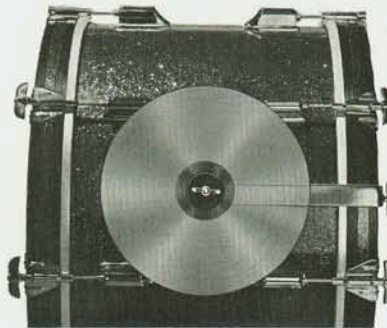

For Concert and Parade Work
999 \$5.50

MARACA STICKS



164 — Shakers — Pair \$3.50

CHIME Mallet



2 SIZES — RAWHIDE

1 — 4 oz. \$5.00
2 — 6 oz. 5.50

All Prices In This Catalog Are
Subject To Change Without Notice

Cymbals Are Not Guaranteed
Against Breakage From Any Cause

**BELL-LYRAS
Made In 3 Sizes**

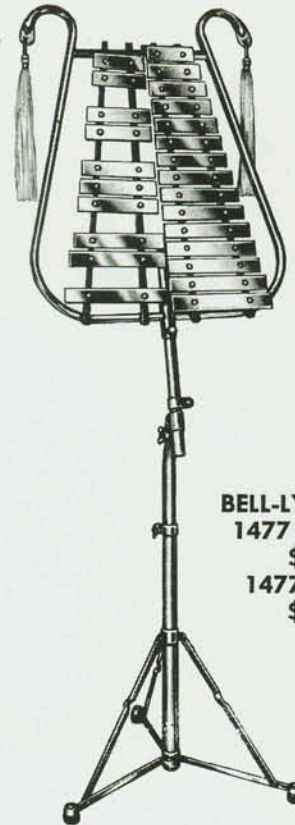

BELL-LYRA STAND
1477 — Chrome
\$22.00
1477 — Nickel
\$18.00

The "EL CAPITAN"

Bars — 1½" x ¾" — Wt. 12 lbs. — Ht. 28"
300 \$135.00

The "DRESS PARADE"

Bars — 1¼" x 5/16" — Wt. 10 lbs. — Ht. 26"
330 \$117.00

The "AMERICAN PATROL"

Bars — 1" x ¼" — Wt. 7 lbs. — Ht. 24"
310 \$96.50

BELL-LYRA SLINGS — SEE PAGE 10

HEAVY BASS DRUM RACK
1" Dia. Tubing — Larger Than Most



Heavy 1" Dia. Steel Tube Rack. Very
Sturdy. Original Design By
Geo. H. Way
4015 — Chrome \$22.50

"CYMBALITE" The Sunshine Of Your Drum Set.

It Restores The Original Color And Sheen To Cymbals

An Exclusive Formula. Use Dry. Do Not Moisten — Sprinkle On A Small Amount And Rub With Dry Cloth. Keep Moving The Rubbing Spot On Cloth To Fresh Areas To Avoid Picked-Up Dirt. Rub Off Powder With Another Dry Clean Cloth.



GLEAMING CYMBALS GIVE MORE PLAYING SATISFACTION
"CYMBALITE" — 4 Ounce Container \$1.50

WALBERG WIRE BRUSHES
The Choice Of Most Professionals



RUBBER COVERED HANDLES

Loop Ends

943 - RC
Pair — \$1.75



RUBBER COVERED HANDLES

Ball Ends

944 - RCRB
Pair — \$1.85

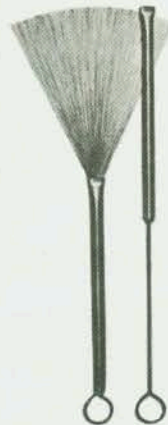

PLAIN ALUMINUM HANDLES

Loop Ends

943
Pair — \$1.75

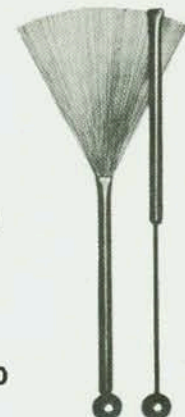

PLAIN ALUMINUM HANDLES

943-B
Pair — \$1.75

"SNAPPY" COILED WIRE SNARES



- 1241 — 12 Strand for 14" Drums \$3.30
- 1242 — 12 Strand for 15" Drums 3.30
- 1245 — 16 Strand for 14" Drums \$3.60
- 1246 — 16 Strand for 15" Drums 3.60
- 1250 — 20 Strand for 14" Drums \$3.90
- 1251 — 20 Strand for 15" Drums 3.90

WEB DRUM SLINGS

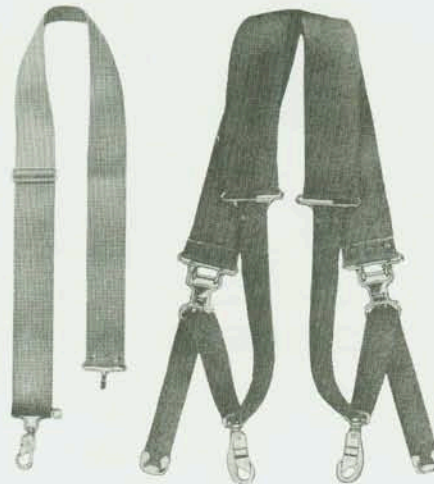

- 4447—Sn. Dr.—White .. \$2.20
- 4453—B. D.—White 4.40

LEATHER BELL-LYRA SLINGS



SINGLE

DOUBLE

- 4855—White \$15.50
- 4853—Tan .. 15.00
- 4857—White \$16.50
- 4856—Tan .. 16.00

PARADE LEG REST

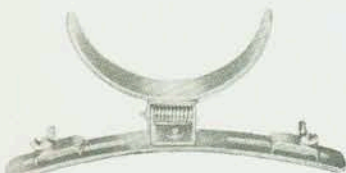

- Rod Mount—Self-Aligning
- 4437—Chrome \$6.80
- 4434—Nickel 4.80

ACME DRUM MAJOR WHISTLE



- Very Shrill — Made in England
- 23—Small \$2.40
- 26—Large 2.50

PARADE DRUM EYE FOR SLING SNAP HOOK



- Fits Under Square Head Rod
- 355 \$.40*

SQUARE HEAD TENSION RODS



Measure from under the collar to end of thread. We carry most lengths. There are a few we cannot supply. All Chrome.
All Lengths—each \$.60*

Fresh Heads Spark Up The Sounds Of Drums

EVANS

REMO

"All-Weather" Plastic Heads

"Weather King" Plastic Heads

BATTER — Light Weight "Symphonic" Extremely Sensitive	14"	\$ 7.50
---	-----	---------

BATTER — Light Weight "Diplomat" Extremely Sensitive	14"	\$ 7.50
--	-----	---------

BATTER — Medium Weight "Orchestra" For All-Around School and Professional Needs. Also Used in Concert Bands	13"	\$ 7.00
	14"	7.50
	15"	8.00

BATTER — Medium Weight "Ambassador" For all-Around School and Professional Needs. Also Used in Concert Bands	13"	\$ 7.00
	14"	7.50
	15"	8.00

BATTER — Heavy Weight "Parade" For Marching Bands and Drum Corps	14"	\$ 7.50
	15"	8.00
	16"	8.50

BATTER — Heavy Weight "Emperor" For Marching Bands and Drum Corps	14"	\$ 7.50
	15"	8.00
	16"	8.50

SNARE — Medium Weight "Orchestra" Especially Designed for Matching with "Symphonic" and "Orchestra" Batters	13"	\$ 6.00
	14"	6.50
	15"	7.00

SNARE — Medium Weight "Ambassador" Especially Designed For Matching With "Diplomat" and "Ambassador" Batters	13"	\$ 6.00
	14"	6.50
	15"	7.00

SNARE — Heavy Weight "Parade" For Marching Bands and Drum Corps	14"	\$ 6.50
	15"	7.00
	16"	7.50

SNARE — Heavy Weight "Emperor" For Marching Bands and Drum Corps	14"	\$ 6.50
	15"	7.00
	16"	7.50

BASS DRUM — Medium Weight For Schools — Dance Bands — Combos — Concert Bands — Show Bands and Orchestras	20"	\$16.00
	22"	17.00
	24"	18.00
	26"	19.50
	28"	21.00
	30"	24.00
	32"	28.00

BASS DRUM — Medium Weight For Schools — Dance Bands — Combos — Concert Bands — Show Bands and Orchestras	20"	\$17.00
	22"	18.00
	24"	19.00
	26"	21.00
	28"	22.00
	30"	23.00
	32"	25.00

BASS DRUM — Heavy Weight For Marching Band and Drum Corps	26"	\$31.00
	28"	34.00

TOM-TOM — Medium Weight Assuring Full Range and Deep Sound In Both FFF and PPP Playing	12"	\$ 6.50
	13"	7.00
	14"	7.50
	15"	8.00
	16"	8.50
	17"	10.00
18"	10.50	

TOM-TOM — Medium Weight "Ambassador" Assuring Full Range and Deep Sounds In Both FFF and PPP Playing	12"	\$ 6.50
	13"	7.00
	14"	7.50
	15"	8.00
	16"	8.50
	17"	9.25
18"	9.75	

TYMPANI Correct Weights For All Sizes	25"	\$28.00
	26"	30.00
	28"	32.00
	30"	36.00

TYMPANI Correct Weights For All Sizes	25"	\$21.00
	26"	22.00
	28"	24.00
	30"	27.00

CALF HEADS — Mounted or Unmounted Supplied at Prevailing Prices

Practice

G H W

Pads . . .

HIGH GRADE DESIGNS THAT MAKE PRACTICE A PLEASURE AND SPEED UP TECHNIQUE

ALL MODELS HAVE 6" GENUINE GUM RUBBER CIRCLES OF THE CORRECT DENSITY TO GIVE REALISTIC DRUM ACTION

PADS THAT TRULY ENCOURAGE MORE HOURS OF PRACTICE

The "SPEEDWAY" SLANT TOP

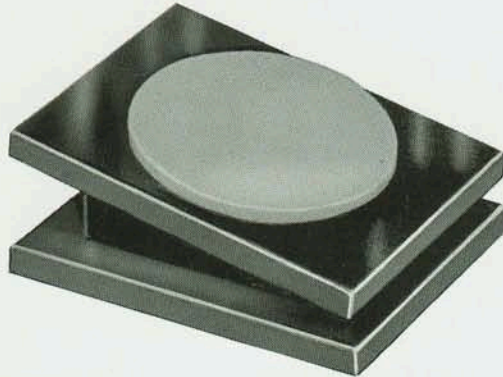

1210 - 9"x7" \$4.95

3
gleaming
enamel
finishes . . .

Choice of:
RED
GREEN
YELLOW

Rubber Bumper Feet
On All Base Boards

All Pads Packaged
in Polyethylene Bags

The "SPEEDWAY" FLAT TOP

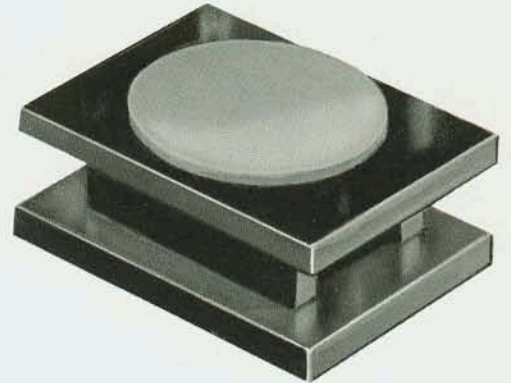

1212 - 9"x7" \$4.95

The "NUWAY" SLANT TOP

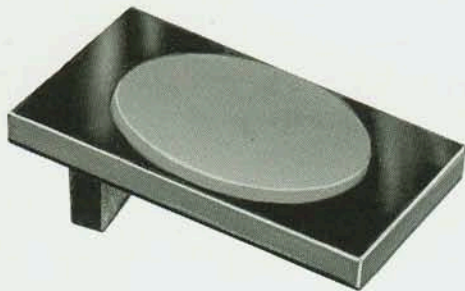

1215 - 9"x7" \$2.95

HEAVY-DUTY PRACTICE PAD STAND



1160—Stand Only.
(Nickel Only) \$9.00

1114—Stand and
Nuway 1220
Flat Top Pad 11.45

The "NUWAY" FLAT TOP



1220 - 9"x7" \$2.45

The "EXTRA" 6" RUBBER DISC



To be carried in pocket or music folio.
Use on table or chair when large pad is
in another location.

1230 \$1.80

The "MUFFLE DRUM" 14" PRACTICE PAD

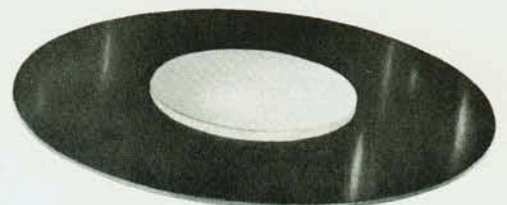

It lies flat on drum head. Play on the
6"x1/4" thick gum rubber disc. Subdued
realistic drum sound without disturbing
those nearby.

1233 \$3.95

LAMBS WOOL BASS DRUM STICKS



LAMB'S WOOL
DOUBLE END
EXTRA LENGTH
4828,
17½" — \$6.30



LAMB'S WOOL
DOUBLE END
REGULAR LENGTH
4827, 16" — \$5.95



LAMB'S WOOL
SINGLE END
4826, 15" — \$5.60



LAMB'S WOOL
WITH SLING
4824, 15" — \$6.75

FELT BASS DRUM STICKS



HIGH GRADE FELT
DOUBLE END
4823,
13½" — \$5.10



HIGH GRADE FELT
SINGLE END
4825, 13" — \$4.20



SUPER GRADE FELT
SINGLE END
4821, 13" — \$4.80



HIGH GRADE FELT
SLING & WOOL GRIP
4820, 13" — \$6.95

SCOTCH BASS DRUM STICKS



SUPER GRADE FELT
MEDIUM HARD
LEATHER THONGS
4830, 14" — \$7.95



HIGH GRADE FELT
MEDIUM HARD
LEATHER THONGS
4829, 14" — \$6.95

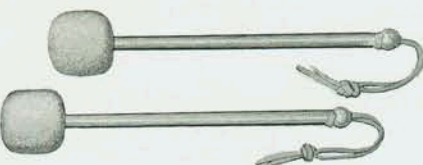

LAMB'S WOOL
SOFT TONES
LEATHER THONGS
4822, 14" — \$8.40

TENOR DRUM STICKS



SUPER GRADE
FELT
12" OVERALL
4834
\$7.45



HIGH GRADE
FELT
12" OVERALL
4831
\$6.50

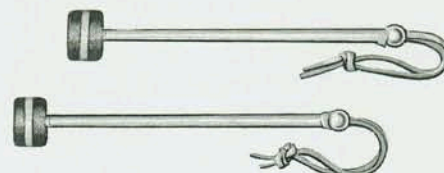

SOLID FELT
11¾" OVERALL
4835
\$6.75

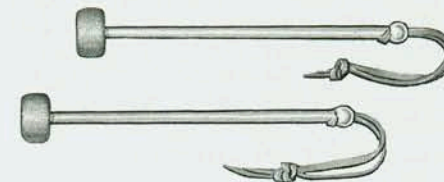

LAMB'S WOOL
12" OVERALL
4832
\$7.80

TYMPANI STICKS



PIANO FELT
DETACHABLE
3812
\$7.00



PIANO FELT
DETACHABLE
3814
\$7.40



PIANO FELT
FIXED BALLS
4843
\$6.30



SOLID FELT
DETACHABLE
3810
\$6.00



LAMB'S WOOL
FIXED BALLS
4845
\$6.60

ABOUT DEAGAN MALLETS



George says . . .

THE J. C. DEAGAN CO. HAS, SINCE THEIR ORIGIN MORE THAN 80 YEARS AGO, GONE TO EXTREME LENGTHS TO MAKE MALLETS OF THE HIGHEST POSSIBLE QUALITY. I RECALL HAVING HEARD (ABOUT 1909) THAT MR. J. C. DEAGAN STATED — "MALLET

FOR MARIMBA, XYLOPHONE AND BELLS ARE AS IMPORTANT TO THE PLAYERS OF THESE INSTRUMENTS AS A FINE BOW IS TO THE CONCERT VIOLINIST." BELIEVING THIS TO BE TRUE, THE COMPANY HAS THROUGH THE YEARS BEEN EVER WATCHFUL IN THE MAKING OF THESE ITEMS. THEY HAVE ALWAYS BEEN ALERT AND READY TO ADOPT BETTER MATERIALS AS THEY BECAME AVAILABLE — AND NEW METHODS AS THEY WERE INVENTED. THEIR RIGID STANDARD FOR FINE WORKMANSHIP, PLUS THE ADDITION OF NEW DESIGNS TO MEET THE UP-TO-DATE STYLES OF PLAYING, HAS KEPT THEM AT THE VERY TOP IN THIS DEPARTMENT. . . . NOW YOU WILL FIND THE GREAT MAJORITY OF LEADING ARTISTS (IN BOTH THE PROFESSIONAL AND SCHOOL FIELDS) USE THE VARIOUS DEAGAN MODELS AS SHOWN ON THIS PAGE.

The TERRY GIBBS DESIGN

FOR PROFESSIONAL MODEL VIBRAHARPS
CORD WOUND HEADS —
RATTAN HANDLES

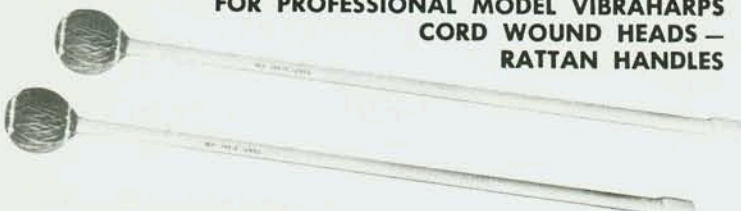

2031 — BLUE, SOFT, Pair	\$6.50
2032 — GREEN, MEDIUM, Pair	6.50
2033 — RED, HARD, Pair	6.50

VARIATION CORD WOUND MALLETS

FOR ALL BAR SIZES — VIBRAHARPS AND MARIMBAS
WHITE MERCERIZED COTTON WOUND HEADS —
RATTAN HANDLES

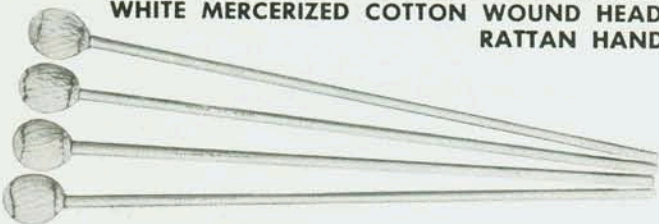

2024 — SET OF 4 — 1 of Each Hardness	\$12.00
2024 — 1 DOT — SOFT, Pair	6.50
2024 — 2 DOTS — MEDIUM SOFT, Pair	6.50
2024 — 3 DOTS — MEDIUM HARD, Pair	6.50
2024 — 4 DOTS — HARD, Pair	6.50

Dots on Handles Identify Hardness

GRADUATED CORD WOUND MALLETS

FOR GENERAL USE ON VIBRAHARPS
OF ALL BAR SIZES —
RATTAN HANDLES

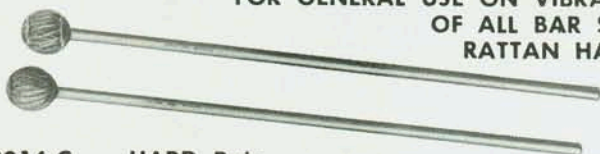

2014-C — HARD, Pair	\$4.80
2015-C — MEDIUM HARD, Pair	4.80
2015½-C — MEDIUM SOFT, Pair	4.80
2016-C — SOFT, Pair	4.80

Heads Are Color Stitched for Identification

VARIATION RUBBER MALLET

FOR MARIMBAS, XYLOPHONES, BELLS,
BELL LYRAS AND VIBRAHARPS —
RATTAN HANDLES



2002 — SOFT, Pair	\$2.60
2002½ — MEDIUM SOFT, Pair	2.60
2003 — MEDIUM HARD, Pair	2.60
2004 — HARD, Pair	2.60
2004½ — EXTRA HARD, Pair	2.60

VARIATION YARN WOUND MARIMBA MALLET

SIZE AND HARDNESS RANGE MEETS EVERY MARIMBA
REQUIREMENT FOR 2, 3 AND 4 Mallet PLAYING —
RATTAN HANDLES



2014-Y — HARD, Pair	\$4.80
2015-Y — MEDIUM HARD, Pair	4.80
2015½-Y — MEDIUM SOFT, Pair	4.80
2016-Y — SOFT, Pair	4.80
2018-Y — LARGE HEAD — SOFT, Pair	4.80
2020-Y — LARGE HEAD — EXTRA SOFT, Pair	4.80

Heads Are Color Stitched for Identification

AL G. WRIGHT BELL-LYRA MALLET



POSITIVELY GUARANTEED UNBREAKABLE BALLS — RUBBER
HANDLE GRIPS — MAGNESIUM STEEL SHAFTS —
FINE BALANCE ASSISTS ACCURATE AIM

Originally suggested by Purdue Univ. Eng. School. Developed
by Geo. H. Way for marketing in collaboration with Al G.
Wright, Director of Bands, Purdue University.

4890 — Pair	\$4.90
-------------------	--------

NYLON ONE-PIECE BELL-LYRA MALLET



MOULDED IN ONE PIECE SOLID NYLON. NOT AFFECTED
BY HEAT OR COLD. NO HANDLE OR BALL TO COME LOOSE.
WILL NOT BREAK. GIVES CLEAR, BRILLIANT TONES.

1740-R — Pair	\$3.00
---------------------	--------

Dependable Drum Protection

MACKINTOSH ZIPPER COVERS

All Sizes Shown Are Shell Measurements
Only — Allowance Is Made For Hoops.
PLEASE STATE TITLE AND SIZE

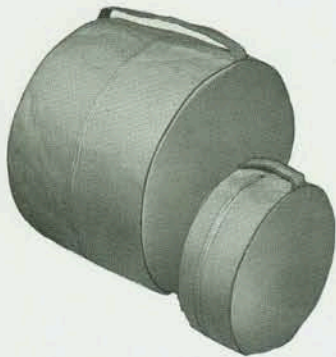

SNARE DRUM COVERS

5" x 14"	\$ 7.80
5½" x 14"	7.80
6½" x 14"	7.80
8" x 15"	7.80

PARADE DRUM COVERS

10" x 14"	\$ 8.70
12" x 15"	9.00
12" x 16"	9.00

TOM-TOM COVERS

8" x 12"	\$ 8.10
9" x 13"	8.10
14" x 14"	9.00
16" x 16"	9.30

BASS DRUM COVERS

14" x 20"	\$13.50
14" x 22"	13.50
14" x 24"	14.30
14" x 26"	15.00
10" x 28"	15.90
14" x 28"	15.90
14" x 30"	16.80
16" x 30"	17.70
16" x 32"	17.70

TYMPANI COVERS

Long Skirt — Pair	\$27.00
-------------------------	---------

NAUGAHYDE COVERS

(Not Illustrated)

5" x 14"	\$ 8.85
5½" x 14"	8.85
6½" x 14"	8.85
8" x 12"	9.15
9" x 13"	9.45
14" x 14"	10.95
16" x 16"	11.55
10" x 14"	11.55
12" x 15"	11.55
14" x 20"	16.50
14" x 22"	17.40

Other Sizes On Request

SUPER CARRY-ALL FIBRE CASE

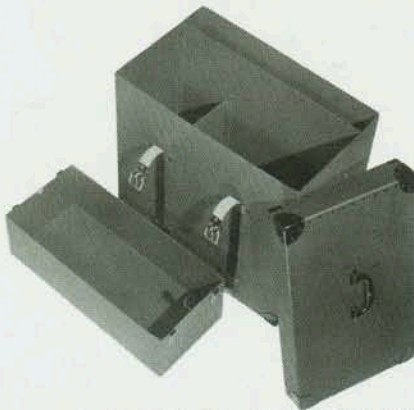

EXTRA LARGE SIZE — TRAY AND TWO PARTITIONS — HOLDS 22" CYMBAL

*21	\$39.50
*21-W—With Wheels	50.00

REGULATION CARRY-ALL FIBRE CASE

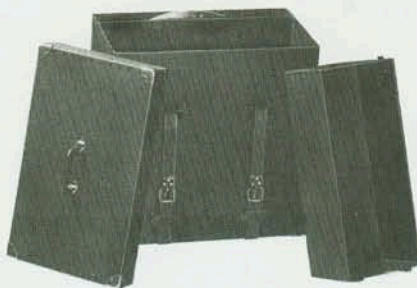

HAS TRAY AND ONE PARTITION — WILL HOLD 15" CYMBAL

*20	\$39.50
-----------	---------

DELUXE FIBRE SUIT CASE

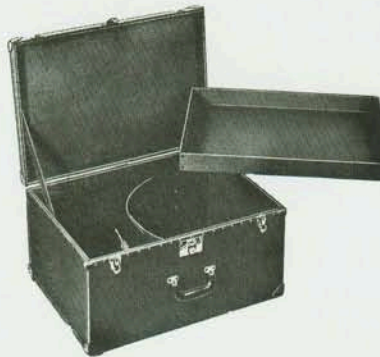

METAL EDGE BODY — HAS TRAY AND PARTITION — HOLDS 16" CYMBAL

*40	\$31.20
-----------	---------

STUDENT FIBRE CASE

ESPECIALLY DESIGNED FOR BEGINNERS — WILL HOLD EITHER 5" x 14" OR 5½" x 14" SNARE DRUM WITH SPACE FOR A FEW ACCESSORIES.

*F49	\$10.10
------------	---------

ROUND TELESCOPE FIBRE CASES

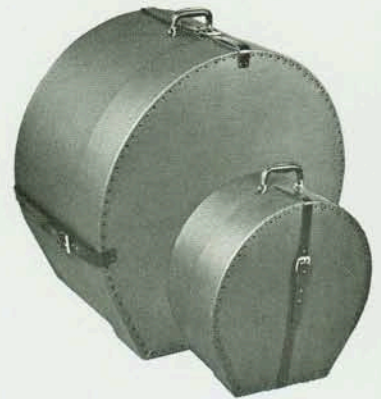

SNARE DRUMS

*14" Dia. Shell to 8" Depth	\$13.40
*15" Dia. Shell to 8" Depth	14.50

PARADE DRUMS

*10" x 14"	\$16.50
*12" x 15"	17.20
*12" x 16"	19.00

TOM-TOMS

* 8" x 12"	\$14.40
* 9" x 13"	14.80
*14" x 14"	18.50
*16" x 16"	19.00

BASS DRUMS

*14" x 20"	\$33.20
*14" x 22"	34.70
*14" x 24"	35.70
*14" x 26"	36.50
*10" x 28"	38.50
*12" x 28"	38.50
*14" x 28"	38.50

Other Sizes — On Special Order

PLAIN EDGE FIBRE SUIT CASE

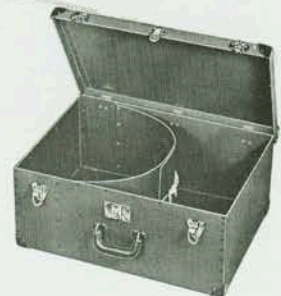

WITH PARTITION—HOLDS 16" CYMBAL

*30	\$21.50
-----------	---------



The House of a Thousand Sounds

THE **G H W** CO.

Drummers' Instruments

1401 North Nappanee St.

Phone 264-4022 (219)

ELKHART, INDIANA 46514

GEO. H. WAY — Owner



Many Drummers Used Them

ABOVE PHOTO TAKEN FOR THE GEO. B. STONE and SON DRUM MFG. CO. CATALOG
AUGUST — 1910 — BOSTON, MASS.

Geo. H. Way — Left (employee of Geo. B. Stone) . . . Geo. Lawrence Stone (Deceased) Son of Geo. B. Stone