



THAT GREAT
GRETSCH
SOUND



THE FRED. GRETSCH MFG. CO.

CATALOG NO. 42

THE PERFECT
MATCH:
THAT GREAT
GRETSCH SOUND

and AMERICA'S
TOP DRUMMERS
who all say
"Gretsch! The Finest Drums
I Ever Owned."



Max Roach



Art Blakey



"Philly" Joe Jones



Chico Hamilton



Elvin Jones



Mel Lewis



Art Taylor



Charlie Persip



Don Lamond



Sonny Payne



Jimmy Cobb

WORLD BEATERS

THE GOLDMAN BAND
PERCUSSION SECTION

The GOLDMAN BAND conducted by Richard Franko Goldman has earned international fame for its inspiring and rousing performances throughout the musical world. Whether outdoors at New York City's Central Park Mall or indoors in concert halls and on Decca and Capitol recordings, Mr. Goldman's percussionists must constantly maintain the highest standard of sound under widely varying conditions. Only the finest drums can answer such rigorous demands. That's why the Goldman drummers choose Gretsch. In cymbals too, the Goldman Band selects only the best — K. Zildjian, world leader in the finest cymbals.



Phil Grant

Paul Fein

Dick Horowitz



NEW

“PROGRESSIVE JAZZ” DRUM OUTFIT

Here's the newest, most modern outfit for the progressive drummer playing with small groups. This great ensemble is exactly like the one played by famous Art Blakey and Max Roach. Modern sound bass drum is 20" x 14" (pioneered by Gretsch); 14" x 4" snare drum—crisp, snappy, with split-second response; and neat tom toms, 12" x 8" and 14" x 14".

PX4025—“Progressive Jazz” Outfit, choice of all Gretsch Pearl finishes and Chrome, special price complete outfit, without cymbals. **\$474.00**

PX4026—“Progressive Jazz” Outfit, choice of all Gretsch Pearl finishes and Chrome, special price complete outfit, with cymbals. **\$625.00**

THE GRETSCH “PROGRESSIVE JAZZ” OUTFIT AS PICTURED IN CHAMPAGNE SPARKLE INCLUDES:

*X4175—Snare Drum, 14" x 4", Pearl and Chrome	\$99.50
X4249—20" x 14" Bass Drum, Pearl and Chrome, (18" x 14" Bass Drum, optional)	130.00
X4415—Tom Tom, 12" x 8", Pearl and Chrome	72.50
X4417—Tom Tom, 14" x 14", Pearl and Chrome	86.50
4942—Rail Console Tom Tom Holder, Chrome	15.00
4930—Legs for 14" x 14" Tom Tom, Chrome(Set of 3)	9.00
4960—Disappearing Spurs, ChromePr.	6.00
5430—Jimmy Pratt Bass Drum Tune Control	8.50
4805—“All-Height” adjustable Cymbal Holder, Chrome	8.50
4826—Cymbal Floor Stand, Chrome	12.00
4983—Snare Drum Stand, Chrome	10.50
4844—Hi-Hat Pedal, Chrome	22.50
4955—“Floating Action” B. D. Pedal	23.50
5220—Drum SticksPr.	1.20
5236—Wire BrushesPr.	1.85
X4688—K. Zildjian 18" Medium Cymbal	52.00
X4690—K. Zildjian 20" Medium Cymbal	62.00
X4685—K. Zildjian 15" Matched Hi-Hat CymbalsPr.	74.00
*X4160, X4157 snare drum optional	Total Value at Regular Prices \$695.05



GRETSCH "BOP" OUTFIT

DESIGNED WITH
FAMOUS DRUMMERS
IN MIND

Up-to-the-minute sound and design, in step with the latest drumming techniques, make this outfit the first choice of famous drum stars. The small bass drum (pioneered by Grétsch) is just one of many innovations. You'll also want the brilliant high-pitched K. ZILDJIAN cymbals — the world's finest — available to you as optional equipment.

PX4010—"Bop" Outfit, choice of all Gretsch Pearl Finishes and Chrome, **special price complete outfit, without cymbals**..... **\$499.00**

PX4011—"Bop" Outfit, choice of all Gretsch Pearl Finishes and Chrome, **special price complete outfit, with cymbals**..... **\$679.00**

THE GRETSCH "BOP" OUTFIT AS PICTURED IN SPARKLE BLUE INCLUDES:

X4157 —14" x 5½" Snare Drum (X4160 optional), Pearl and Chrome...	\$99.50
X4249 —20" x 14" Bass Drum (22" x 14" optional), Pearl and Chrome	130.00
X4418 —16" x 16" Tom Tom, Pearl and Chrome.....	92.50
X4416 —13" x 9" Tom Tom, Pearl and Chrome.....	75.50
4930 —Legs for 16" x 16" Tom Tom, Chrome.....(Set of 3)	9.00
4942 —Rail Console/ette T. T. Holder, Chrome.....	15.00
4955 —"Floating Action" Bass Drum Pedal.....	23.50
4844 —Hi-Hat Pedal, Chrome.....	22.50
4805 —"All-Height" Cymbal Holder, Chrome.....	8.50
4826 —Cymbal Floor Stands, Chrome.....(2 pc. @ \$12.00)	24.00
4960 —Disappearing Bass Drum Spurs, Chrome.....Pr.	6.00
5430 —Jimmy Pratt Bass Drum Control.....	8.50
5236 —Wire Brushes.....Pr.	1.85
5220 —Drum Sticks.....Pr.	1.20
4983 —Snare Drum Stand, Chrome.....	10.50
X4684 —K. Zildjian 14" Matched Hi-Hat Cymbals.....Pr.	68.00
X4685 —K. Zildjian 15" Medium Cymbal.....	37.00
X4688 —K. Zildjian 18" Medium Cymbal.....	52.00
X4690 —K. Zildjian 20" Medium Cymbal.....	62.00

Total Value at Regular Prices \$747.05

“ THAT GREAT
GRETSCH
 SOUND ”

For more than three-quarters of a century, The Fred. Gretsch Mfg. Company has been dedicated to the sound of drums...making news with a host of important technical "firsts"...perfecting the "Great Gretsch Sound" with the precise, quality construction famous drummers demand.

Why is "That Great Gretsch Sound" so outstanding? It is the superb tonal quality built into each Gretsch instrument. Response is quick and lively. And your Gretsch drum holds its tension, regardless of weather.

Step by step, Gretsch drums are meticulously constructed to last throughout your career, make a handsome appearance, and sound great.

Gretsch—first with the small bass drum, first with disappearing drum spurs, first with built-in adjustable bass drum, tone control and Micro-Sensitive Snare Strainer...first with self-seating,

self-aligning, strip-proof tensioning throughout... and first with the unique molded 6-ply/shell construction, guaranteed for life, that assures perfect roundness, shell strength, and distortion-free sound. The gleaming chrome-plated hoops, too, have the exclusive plus of die-cast molding to give you superior sound and stick protection on your rim shots.

These are but a few of the reasons "That Great Gretsch Sound" has become a byword and a source of confidence to drummers throughout the world...on bandstands and marching grounds alike. Naturally, we're proud of our reputation. It comes from many years of technical and musical know-how, many years of keeping pace with progress and remaining alert to your needs. In the years ahead, you can depend on the same dedication, the same high standards to bring new heights of greatness to "That Great Gretsch Sound."

INDEX

Bass Drums, Concert	8, 9	Drum Outfits	3-7	Practice Pads	Page 23
Bass Drums, Dance	8	Drum Repair Parts	20, 21	Rail Consolettes	12
Bass Drums, Marching	27-30	Drum Rod Assemblies	21	Scotch Bass Drums	27-30
Bass Drum Heads	24	Drum Rod Casings (Lugs)	21	Shakers, Latin-American	17
Bass Drum Sticks	23	Drum Slings	18	Slings, Drum	18
Bells	25	Drum Stands	19	Snare Drum Heads	24
Bell Mallets	23	Drum Sticks	22, 23	Snare Drum Hoops	21
Bongos	17	Drummer Thrones	19	Snare Drums, Orchestra & Band ..	9, 10, 11
Bongo Heads	24	Flesh Hoops	19	Snare Drums, Marching	27-30
Books, Instruction	31	Glockenspiel & Accessories	25	Snare Drums	20
Brushes, Wire Drum	22	Glockenspiel Mallets	23	Snare Drum Sticks	22
Calf Heads	24	Gourds (Güiros)	17	Snare Strainers	20
Cases, Drum and Tom Tom	18	Heads, Drum	24	Spurs, Bass Drum	19
Castanets, Drummer	26	Hi-Hat Pedals	16	Stands, Cymbal	15
Claves	17	Hooks, Drum	21	Stands, Drum	19
Cocktail Drums	13	Hoops, Drum	21	Sticks, Timbale	26
Counter Hoops	21	Instruction Books	31	Sticks, Snare Drum	22
Covers, Drum and Tom Tom	18	K. ZILDJIAN Cymbals	14	Sticks, Tympani	23
Cowbells and Holders	19	Keys, Drum	20	Sticks, Bass Drum	23
Cymbals	14, 15	Keys, Rail Consolette	20	Sticks, Scotch Bass & Tenor Drum	23
Cymbal Accessories	15	Leg Rests, Drum	18	Tambourines	26
Drums, Bass, Concert	8, 9	Lugs, Drum	21	Tenor Drums	27-30
Drums, Bass, Dance	8	Mallets, Percussion	23	Thrones, Drummer	19
Drums, Bass, Scotch	27-30	Maracas	17	Timbales	26
Drums, Cocktail	13	Marimba Mallets	23	Timbale Sticks	26
Drums, Snare, Orchestra & Band ..	9, 10, 11	PERMA-TONE Heads	24	Tom Toms and Accessories	12
Drums, Snare, Marching	27-30	Pedals, Drum	16	Tom Tom Hoops	21
Drums, Tenor	27-30			Triangles	26
Drum Covers & Cases	18			Tympani Heads	24
Drum Hardware	21			Tympani	25
Drum Heads	24			Tympani Sticks	23
Drum Hooks	21			Woodblocks and Holders	19
Drum Hoops	21			Xylophone Mallets	23



GRETSCH "NAME BAND" OUTFIT

COMPLETE OUTFIT
FOR DRUMMERS

Top-flight drummers find here everything they need for serious professional work. The modern design and superb craftsmanship make the "Name-Band" outfit ideal for big band, floor shows and combo use. Attractive, too — drums and tom-toms feature Chrome plated parts at no extra cost.

PX4015—"Name-Band" Outfit, choice of all Gretsch Pearl finishes and Chrome, special price complete outfit, but without cymbals. **\$492.00**

PX4016—"Name-Band" Outfit, choice of all Gretsch Pearl finishes and Chrome, special price complete outfit, with cymbals. **\$619.00**

THE GRETSCH "NAME-BAND" OUTFIT AS PICTURED
IN SPARKLE SILVER INCLUDES:

X4157 — 14" x 5½" Snare Drum (X4160 optional), Pearl and Chrome.	\$99.50
X4247 — 22" x 14" Bass Drum (20" x 14" optional), Pearl and Chrome	139.00
X4418 — 16" x 16" Tom Tom, Pearl and Chrome	92.50
X4416 — 13" x 9" Tom Tom, Pearl and Chrome	75.50
4930 — Tom Tom Legs, Chrome (Set of 3)	9.00
4942 — Rail Console T.T. Holder, Chrome	15.00
4805 — "All-Height" Adjustable Cymbal Holder, Chrome (2 @ 8.50 ea.)	17.00
4844 — Hi-Hat Pedal, Chrome	22.50
4960 — Disappearing Bass Drum Spurs, Chrome Pr.	6.00
5430 — Jimmy Pratt Bass Drum Tone Control	8.50
5236 — Wire Brushes Pr.	1.85
5220 — Drum Sticks Pr.	1.20
4955 — "Floating Action" Bass Drum Pedal	23.50
4983 — Snare Drum Stand, Chrome	10.50
X4685 — K. Zildjian 15" Medium Cymbal	37.00
X4686 — K. Zildjian 16" Medium Cymbal	42.00
X4684 — K. Zildjian 14" Matched Hi-Hat Cymbals Pr.	68.00

Total Value at Regular Prices \$668.55



GRETSCH "ONE NIGHTER PLUS"

For your club and combo work, here's a compact ensemble that's ideal for traveling. A truly professional separate tension outfit, the "One-Nighter Plus" includes Tom Tom and Rail Console. Buy the complete outfit with the K. Zildjian Cymbal and save!

PX4007—"One-Nighter Plus" choice of all Gretsch Pearl finishes and Chrome, special price complete outfit, but without cymbal. **\$359.00**

PX4008—"One-Nighter Plus" choice of all Gretsch Pearl finishes and Chrome, special price complete outfit, with cymbal. **\$395.00**

THE GRETSCH "ONE-NIGHTER PLUS!" AS PICTURED IN MIDNIGHT BLUE PEARL INCLUDES:

X4157 - 14" x 5½" Snare Drum in Pearl and Chrome.	\$99.50
X4247 - 22" x 14" Bass Drum in Pearl and Chrome	139.00
X4416 - 13" x 9" Tom Tom in Pearl and Chrome	75.50
4942 - Rail Console Tom Tom Holder, Chrome	15.00
X4686 - K. Zildjian 16" Medium Cymbal	42.00
4805 - "All-Height" Cymbal Holder, Chrome	8.50
4955 - "Floating Action" Bass Drum Pedal	23.50
4960 - Disappearing Bass Drum Spurs, ChromePr.	6.00
5430 - Jimmy Pratt Bass Drum Tone Control	8.50
4983 - Snare Drum Stand, Chrome	10.50
5220 - Drum SticksPr.	1.20
5236 - Wire BrushesPr.	1.85
Total Value at Regular Prices \$431.05	

PX4002—"ONE NIGHTER PLUS" OUTFIT—with 20" x 14" Base Drum, 12" x 8" Tom Tom and 14" x 5½" Snare Drum. Includes all accessories as listed in the PX4007 outfit. Without cymbals. **\$348.00**

PX4003—Same as PX4002 outfit but with X4686 K. Zildjian 16" cymbal. **\$384.00**

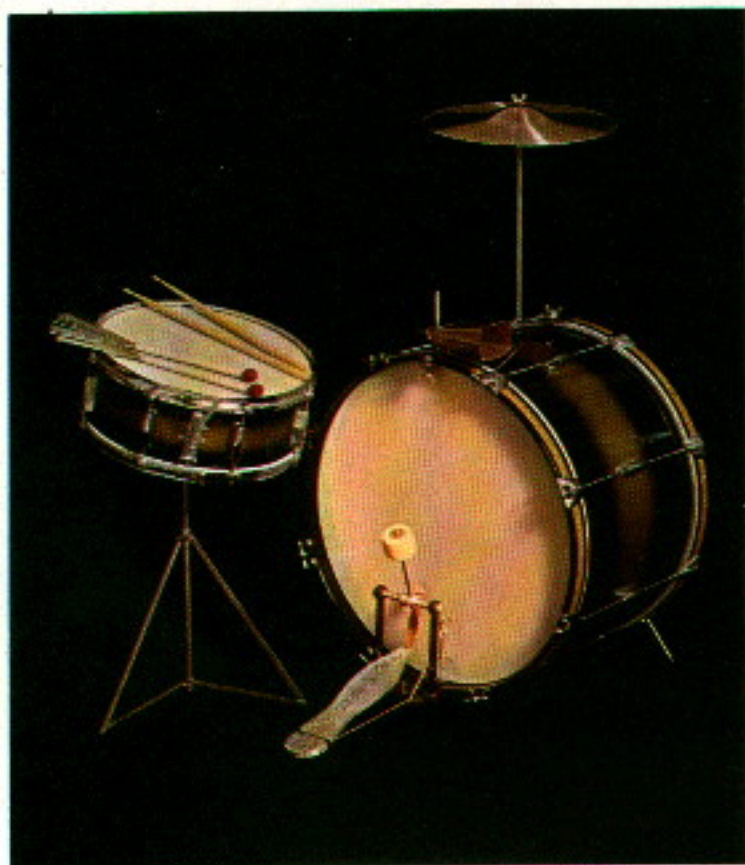

GRETSCH

"SEMI-PRO" OUTFIT

For part-time professionals and serious drum students—here's a really practical outfit. Solidly built to professional standards, made to last beyond your semi-pro and student days. All of the basic equipment you need is included.

PX4040—"SEMI-PRO" Drum Outfit in Tri-Tone Black & Gold Lacquer and Chrome. Special price complete outfit. . . . **\$196.00**

THE GRETSCH "SEMI-PRO" OUTFIT AS PICTURED IN TRI-TONE BLACK & GOLD LACQUER AND CHROME INCLUDES:

X4102 —"Renown" Snare Drum (14" x 5½") in Tri-Tone Black & Gold Lacquer and Chrome	\$58.00
X4280 —Bass Drum (22" x 14") in Tri-Tone Black & Gold Lacquer and Chrome	93.00
4905—Cowbell, 3½"	1.50
4912—Cowbell Holder	1.50
4956—Professional Bass Drum Pedal	19.00
X4740 —Ajaha Cymbal, 14"	18.00
4810—Cymbal Holder, 14"	3.00
4968—Bass Drum Spurs	Pr. 1.50
5236—Wire Brushes	Pr. 1.85
5220—Drum Sticks	Pr. 1.20
4980—Snare Drum Stand	5.50
9329—"All American Drummer"	1.00

Total Value at Regular Prices \$205.05

GRETSCH

"RENOWN" DRUM OUTFIT

Young drummers and students go for this moderately priced outfit. Includes every instrument and accessory needed for the study and practice of full dance drumming routine.

A really solid, fine-toned ensemble.

PX4055—"RENOWN" Outfit as described in Tri-Tone Blue & Silver Lacquer and Chrome. Special price complete outfit. **\$227.00**

THE GRETSCH "RENOWN" OUTFIT AS PICTURED IN TRI-TONE BLUE & SILVER LACQUER AND CHROME INCLUDES:

X4102 —Snare Drum (14" x 5½") in Tri-Tone Lacquer and Chrome	\$58.00
X4280 —Bass Drum (22" x 14") in Tri-Tone Lacquer and Chrome	93.00
X4140 —Tom Tom (12" x 8") in Tri-Tone Lacquer and Chrome	45.00
4935—Tom Tom Holder, Chrome	5.00
X4738 —Ajaha Cymbal, 12"	12.00
4905—Cowbell, 3½"	1.50
4912—Cowbell Holder	1.50
4810—Cymbal Holder, 14"	3.00
4956—Professional Bass Drum Pedal	19.00
4968—Bass Drum Spurs	Pr. 1.50
5230—Wire Brushes	Pr. 1.05
5220—Drum Sticks	Pr. 1.20
4980—Snare Drum Stand	5.50
9329—"All American Drummer"	1.00

Total Value at Regular Prices \$248.25





GRETSCH

"DIXIELAND" DRUM OUTFIT

The famous quality of sturdy Gretsch construction, plus extra zip in color and design give student and young drummers good sound and professional flash.

PX4070—"DIXIELAND" Drum Outfit as described in Tri-Tone Green & Silver Lacquer and Chrome. Special price complete outfit**\$169.50**

THE GRETSCH "DIXIELAND" OUTFIT AS PICTURED IN TRI-TONE GREEN & SILVER LACQUER AND CHROME INCLUDES:

X4104 - Snare Drum, 14" x 5½" in Tri-Tone Lacquer and Chrome	\$52.00
X4110 - Bass Drum, 22" x 14" in Lacquer and Chrome	88.50
4956 - Professional Bass Drum Pedal	19.00
4968 - Drum Spurs	Pr. 1.50
4905 - Cowbell, 3½"	1.50
4912 - Cowbell Holder	1.50
X4738 - Ajaha 12" Cymbal	12.00
4810 - Cymbal Holder	3.00
4980 - Drum Stand	5.50
5220 - Drum Sticks	Pr. 1.20
5230 - Wire Brushes	Pr. 1.05
9329 - "All American Drummer"	1.00

Total Value at Regular Prices \$187.75

GRETSCH

"JAZZ COMBO" OUTFIT

You'll like the sound and looks of this low-priced outfit. Ideal for students on the way up. Just one of the quality features: the center post brace for tension rods, assuring perfect alignment.

And, of course, Gretsch gives you a great showpiece, too.

At any price, Gretsch colors have real flash and beauty.

PX4077—"JAZZ COMBO" Drum Outfit Tri-Tone Blue & Silver Lacquer and Chrome. Special price complete outfit.**\$137.00**

THE GRETSCH "JAZZ COMBO" OUTFIT AS PICTURED IN TRI-TONE BLUE & SILVER LACQUER AND CHROME INCLUDES:

X4207 - Snare Drum, 14" x 5"	\$37.50
X4113 - Bass Drum, 22" x 12"	79.00
4950 - Speedee Pedal	8.00
4968 - Drum Spurs	Pr. 1.50
4905 - Cowbell, 3½"	1.50
4912 - Cowbell Holder	1.50
X4738 - Ajaha Cymbal, 12"	12.00
4810 - Cymbal Holder	3.00
4980 - Drum Stand	5.50
5220 - Drum Sticks	Pr. 1.20
5230 - Wire Brushes	Pr. 1.05
9329 - "All American Drummer"	1.00

Total Value at Regular Prices \$152.75



GRETSCH BASS DRUMS

DANCE AND
CONCERT
MODELS

On concert stage or on the dance job, Gretsch Bass Drums meet the professional's stiffest requirements. Big, resonant tone and extra years of dependable service are built right into these handsome, streamlined drums... along with all of the fine features you've come to expect from Gretsch.

- Exclusive 6-ply molded shells and hoops guaranteed perfect round for the life of the drum
- Streamlined Rod Casings • New Claw Hooks and Kettle Handle Rod
- Self-seating, Self-aligning, Strip-proof Tensioning
- Radiant Gretsch-Pearl or Lacquer
- All with metal parts in Chrome plate

SEPARATE TENSION DANCE BASS DRUMS



Individual, newly designed, streamlined tension casings. Finishes and specifications as above. In Gretsch-Pearl & Chrome.

Gretsch-Pearl & Chrome		Shell Size
X4244	\$125.00	18" x 14"
X4249	130.00	20" x 14"
X4247	139.00	22" x 14"
X4269	149.00	24" x 14"

SEPARATE TENSION CONCERT BASS DRUMS

Stock finish is hand polished Mahogany shell and natural rock Maple hoops. Also available on special order in any solid color or Tri-Tone hand polished Lacquer (pearl inlaid hoops, \$5.00 extra) or in Gretsch-Pearl with inlaid hoops as quoted. These drums are supplied with two heavy metal carry-rings for bass drum sling.

Mahog. or Lacquer & Chrome	Shell Size	Gretsch-Pearl & Chrome
X4259	26" x 14"	X4271 \$153.00
X4260	28" x 14"	X4272 164.00
X4262	30" x 16"	X4273 180.00
X4263	32" x 16"	X4274 195.00



SINGLE TENSION CONCERT BASS DRUMS

With newly designed center rod casings and kettle handle rods. Finishes and specifications as described above.



Mahog. or Lacquer & Chrome	Shell Size	Gretsch-Pearl & Chrome
X4281	24" x 14"	X4293 \$129.50
X4283	26" x 14"	X4295 139.50
X4284	28" x 14"	X4296 151.50
X4285	30" x 16"	X4297 172.50
X4286	32" x 16"	X4298 186.50

FEATURING: Exclusive 6-ply molded shells and hoops, guaranteed perfect round for the life of the drum. Low in price, high in quality, Gretsch "Renown" Bass Drums also feature Easy-Grip Kettle Handle Rods. Mahogany shell with natural color rock Maple hoops. Chrome plate metal parts. (Solid color or Tri-Tone Lacquer available at slight extra cost.)

GRETSCH BASS DRUMS



"RENOWN" BASS DRUMS IN MAHOGANY & CHROME

X4110—Size, 22" x 14"	\$82.50
X4111—Size, 24" x 14"	86.50
X4115—Size, 26" x 14"	93.50
X4117—Size, 28" x 14"	102.50

For solid color Lacquer, one or two colors, add \$2.00 extra.

For Tri-Tone Lacquer add \$3.00 extra.

For Pearl-inlaid hoops add \$5.00 extra.

GRETSCH POWER SNARES



It's here! The sound of *extra power* in the new Gretsch Power Snares for the crispest, sharpest drumming to date! The wide band of 42-metal snares provides extra-power, extra-snap and extra-response resulting in better and more outstanding player performance.

The new Gretsch 42 strand Power Snares with its improved and different tone is the answer for the drummer seeking the best in snare sound.

Available separately and as standard equipment on models so listed in catalog.

GRETSCH METAL SNARE DRUM



For the modern drummer who demands perfection in tone and the sharp, crisp sound traditionally found in a metal snare drum, the Gretsch Metal Snare Drum is the first choice. Top professionals find Gretsch's 14" x 5" seamless spun brass shell and quality construction give the utmost in response. Featuring a "Micro-Sensitive" strainer with adjustable butt end. 42 strand "Power" all metal snares, polished Chrome shell, and all other metal parts. Fully Flanged Metal Hoops, Self-Seating, Self-Aligning, Strip-proof Tensioning, Streamlined Casings. Snap-in key and Holder.

X4160 — Gretsch Chrome plated Metal Shell Snare Drum, 14" x 5"	\$99.50
---	---------

GRETSCH

PROFESSIONAL SNARE DRUMS

PERFECTION IN TRUE SNARE DRUM TONE CLEAN, CRISP, HIGHLY-RESPONSIVE

FAMOUS GRETSCH SPECIFICATIONS

• Exclusive 6-ply molded shells, guaranteed perfect round for life of drum • Fully Flanged Metal Hoops Self-Sealing, Self-Aligning, strip-proof tensioning Streamlined Casings • "Micro-Sensitive" Snare Strainer for quick, positive throw-off • Built-in tone control • Dazzling Gretsch-Pearls, Sparkles, Lacquer, all with Chrome. • Snap-in key and Holder.

Our finest snare drums by far in many years of drum-making. Important advances in design and construction, such as improved tensioning and tuning adjustments, heighten accuracy and sensitivity. But, as in all Gretsch instruments, TONE is the most outstanding feature... and for that unmistakable, distinctive Gretsch tone, look to our exclusive 6-ply molded shell construction. It's your guarantee of perfect round and pure tone for the life of the drum.

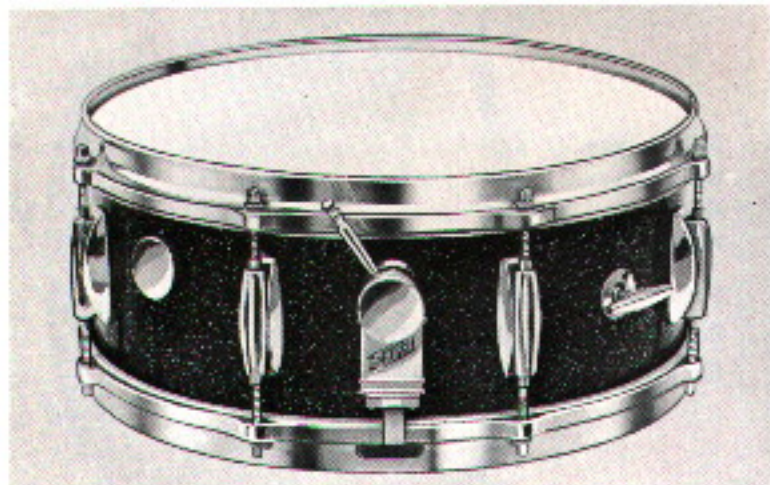

NAME BAND MODEL

Super-sensitive separate tension orchestra snare drum with 14" x 5½" shell and 42 strand "Power" all-metal snares, plus all the other features described elsewhere on these pages. This is the model used by many famous artists who like its sharper tone and faster action. Chrome plated metal parts.

- X4155 - 14" x 5½" Hand polished Mahogany or colored Lacquer; & Chrome \$89.50
- X4157 - 14" x 5½" GRETSCH-PEARL & Chrome \$99.50

"PROGRESSIVE JAZZ" MODEL

This is "it" for many famous drum stars. The feature-packed Gretsch snare drum with modern, new narrow styling (only 4 inches deep) designed to give crisper, faster response. And, the Gretsch "Micro-Sensitive" Snare Strainer has Feather-Touch control for quick, positive throw-off of "Power" all-metal 42 strand snares. Streamlined Separate Tension Casings. Fully Flanged Hoops. In Gretsch-Pearl and Chrome.

- X4175 - 14" x 4", Snare Drum in Gretsch-Pearl & Chrome \$99.50

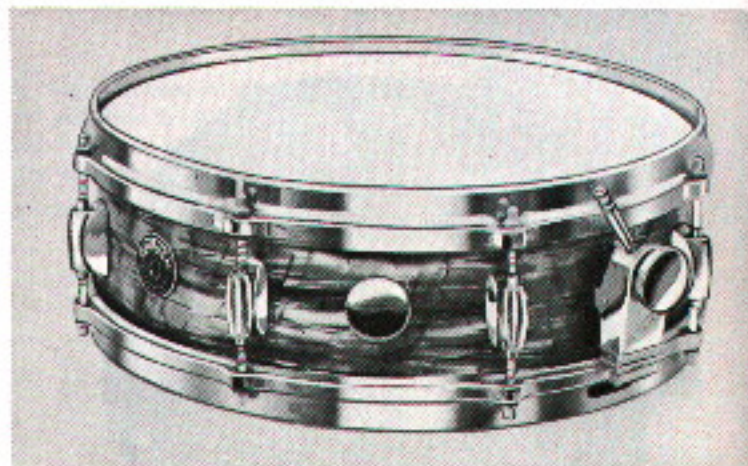
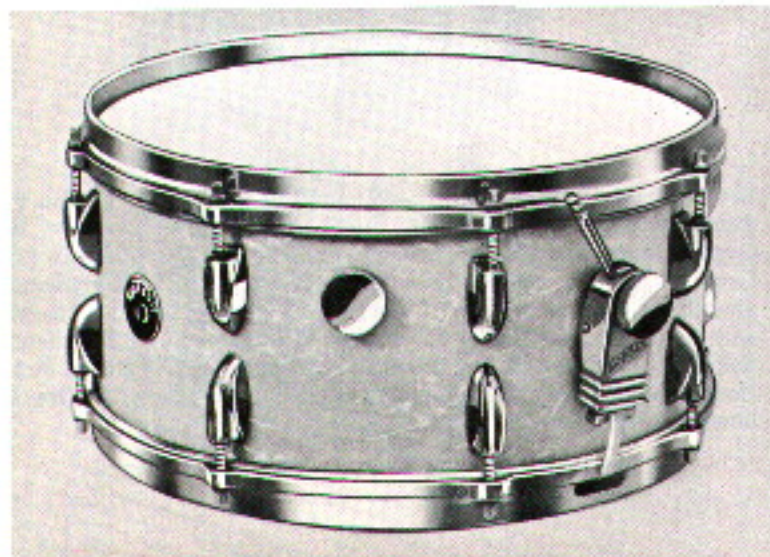

FLOOR SHOW MODEL SNARE DRUM

Popular separate tension orchestra snare drum with 14" x 6½" shell and 42 strand "Power" all-metal snares. This drum embodies all quality features as listed elsewhere on these pages

- X4151 - Snare Drum 14" x 6½" hand polished Mahogany or colored Lacquer; and Chrome \$93.00
- X4153 - Snare Drum 14" x 6½" GRETSCH - PEARL and Chrome \$103.00

GRETSCH SNARE DRUMS

GRETSCH "RENOWN" SEPARATE TENSION SNARE DRUM



GRETSCH CONCERT SNARE DRUM

Sharp, powerful separate tension snare for the concert band or orchestra. Standard finish is hand-polished Mahogany. Also available in Tri-Tone or solid color Lacquer at no extra charge. Polished gut snares, metal parts in Chrome plate. ("Responso" all-metal snares optional at no extra cost.)

- X4190—Shell 14" x 7", Mahog. and Chrome **\$88.50**
- X4191—Shell 14" x 7", Gretsch-Pearl & Chrome **98.50**
- X4192—Shell 15" x 8", Mahog. and Chrome **92.00**
- X4193—Shell 15" x 8", Gretsch-Pearl & Chrome **102.00**



"JUNIOR PRO" SINGLE TENSION SNARE DRUM

Even at our low price, you get the famous Gretsch 6-ply molded shell for guaranteed perfect round, fine tone and snappy response. Metal counter-hoop; six key-tension rods, professional style; standard throw-off snare strainer; silk, wire-wound snares. Natural Mahogany or Lacquer in Black or White. METAL PARTS IN CHROME PLATE!

- X4205—"Junior Pro" Snare Drum, shell 14" x 5" **\$27.50**

FEATURING: Gretsch-Exclusive Molded 6-ply shells, guaranteed perfect round for the life of the drum. Double Flanged Hoops • Self-Seating, Self-Aligning Tensioning • Modern Rod Casings • Positive Snare Throw-Off • "Responso" Metal Snares

• Snap-in Key Holder (Patent Pending)

Minimum-priced separate tension snare drum that combines good looks with sturdy build, fine tone and easy-action playing adjustments. Excellent choice for budget-minded schools, junior drummers, part-time professionals.

- X4102—"Renown" Separate Tension Snare Drum Shell, 14" x 5 1/2", in Mahogany or colored Lacquer and Chrome **\$58.00**
- X4103—"Renown" Snare Drum, Pearl finish and Chrome .. **68.00**



"DIXIELAND" SEPARATE TENSION SNARE DRUM

Top value in this modern orchestra snare drum! The shell (14" x 5 1/2" size) is the 6-ply molded construction that guarantees perfect round for the life of the drum. Double Flanged, non-rusting hoops; Streamlined Tension Rod Casings; Standard Throw-Off Snare Strainer with snare bracket; 12 strand "Responso" all-metal Snares. Metal parts in Chrome plate!

- X4104—"Dixieland" Snare Drum, 14" x 5 1/2", Red, White, Black, or Blue metallic Lacquer and Chrome **\$52.00**
- X4105—"Dixieland" Snare Drum, 14" x 5 1/2", Gretsch-Pearl & Chrome **\$56.00**

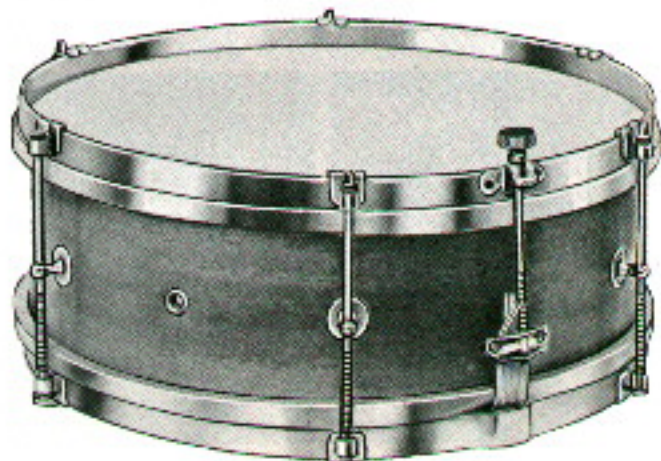

GRETSCH TOM TOMS

FEATURING: Gretsch EXCLUSIVE 6-ply molded shells, guaranteed perfect round for the life of the drum • Fully Flanged molded Counter Hoops • Self-seating, Self-aligning, strip-proof Tension Rods • Streamlined Rod Casings • Built-in tone controls.

Available in your choice of Gretsch-Pearls, Sparkles or Lacquers and Chrome. Gretsch Tom Toms are finished in gleaming, long-lasting Chrome plate at no extra charge.

GRETSCH SEPARATE TENSION TOM TOMS

With all construction specifications and finishes as listed above. Note that these tom toms are fitted with two separate tone-controls, one for each head.

LACQUER & CHROME

X4405 - Shell, 12" x 8"	\$64.00
X4406 - Shell, 13" x 9"	68.00
X4407 - Shell, 14" x 14"	79.00
X4408 - Shell, 16" x 16"	80.00
X4409 - Shell, 18" x 16"	93.00

GRETSCH-PEARL & CHROME

X4415 - Shell, 12" x 8"	\$72.50
X4416 - Shell, 13" x 9"	75.50
X4417 - Shell, 14" x 14"	86.50
X4418 - Shell, 16" x 16"	92.50
X4419 - Shell, 18" x 16"	110.50

FLOOR LEGS AND BRACKETS FOR LARGE TOM TOMS

Non-slip type, adjustable to height. Metal parts in Chrome plate.

4930 - Tom Tom Legs and Brackets, for 14" x 14" and 16" x 16" Tom Toms . . .	\$9.00
	(Set of 3)
4931 - Tom Tom Legs and Brackets, for 18" x 16" Tom Toms	(Set of 4) 12.00

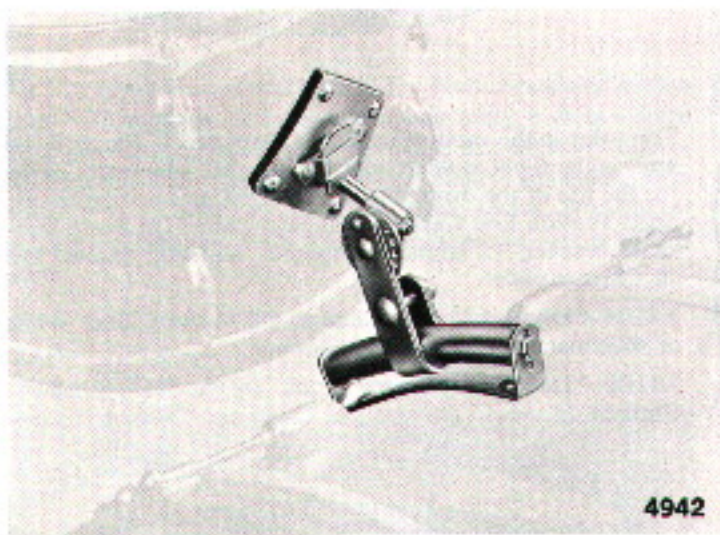

4942

RAIL CONSOLE TOM TOM HOLDER

Truly professional in convenience, utility and appearance. The rail consolelette attaches permanently to the bass drum. Has adjustable bracket (folds down for carrying) into which fits the metal plate attached to the tom tom. Adjusts to height and playing angle. Holds the tom tom rigidly and securely.

4942 - Rail Consolelette Tom Tom Holder, Chrome . . .	\$15.00
4943 - Diamond Plate only for Tom Tom shell, Chrome	2.50

HEAVY DUTY RATCHET TOM TOM HOLDER

Professional ratchet-type tom tom holder adjusting to height and playing angle; locks securely in position, Chrome.

4940 - Heavy-duty Ratchet Tom Tom Holder, Chrome.	\$9.00
---	---------------

UTILITY MODEL, RATCHET-TYPE TOM TOM HOLDERS

Inexpensive holder for tunable tom toms, adjustable to height and playing angle. Made of heavy steel. Complete with hoop clamp.

4935 - Utility Tom Tom Holders, Chrome	\$5.00
--	---------------



4940



4935

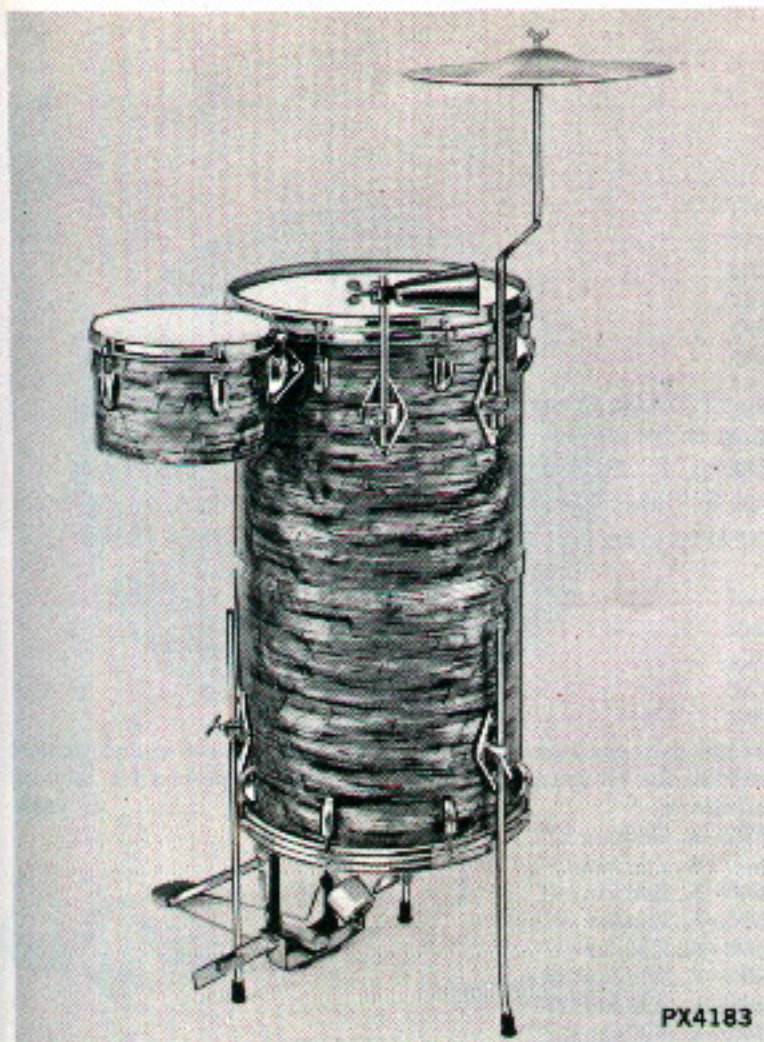

PX4183



PX4180

GRETSCH COCKTAIL DRUMS

The popularity of the Gretsch Cocktail Drum keeps growing. Cocktail lounge units and other small combos who don't employ a full time drummer find it an easy way to add color to the group. The snare attachment under the top head sounds brisk and sharp with brushes. A quick release of the snare, and you have a deep tom tom tone. For going Latin, or other special effects, use the cowbell and hongo tom.

Gretsch Cocktail Drums feature: 6-ply molded shell, guaranteed perfect round for the life of the drum; rust-proof Flanged Counter Hoop; Streamlined Tension Casings with Self-aligning, Self-seating Rods. All metal parts in Polished Chrome plate, at no extra cost. Choice of exclusive Gretsch Pearl & Sparkle finishes.

GRETSCH COCKTAIL DRUM DELUXE OUTFITS

These are the regular Gretsch Cocktail Drums described above with additional equipment as follows: 8" x 5½" Bongo-Tom in finish to match the drum, with holder; Cowbell, 5", with holder; and Cymbal Holder (cymbal not included).

PX4182—Gretsch Cocktail Drum Outfit, 14" x 24", single head model. Like PX4180 but with additional equipment as listed above. In choice of Gretsch-Pearl finishes with Chrome plated metal parts at no extra charge. **\$145.00**

PX4183—Gretsch Cocktail Drum Outfit, 14" x 26", double head model. Like PX4182 but with bottom head, pedal bar, and up-side-down pedal. Choice of Gretsch-Pearls, with Chrome plated metal parts at no extra charge. **\$225.00**

GRETSCH COCKTAIL DRUMS (ONLY)

PX4180—Gretsch Cocktail Drum, Shell size 14" diameter, 24" deep. Single head model with underneath-snares and throw-off snare strainer. Complete with legs (3) in choice of Gretsch-Pearl and with Chrome plated metal parts at no extra charge. **\$95.00**

PX4181—Gretsch Cocktail Drum, Shell size 14" diameter, 26" deep. This drum has a bottom head and is supplied with an up-side-down pedal and a pedal bar, thus providing bass drum tone in addition to snare drum and tom tom effects. Complete with legs (3) in choice of Gretsch-Pearl finishes and with Chrome plated metal parts at no extra charge. **\$175.00**

K. ZILDJIAN®

GENUINE TURKISH CYMBALS

To drum stars such as Art Blakey, Elvin Jones, "Philly" Joe Jones and Charlie Persip, perfection in performance and sound is vital. That's why these jazz drum greats—and so many others insist on the distinctive tone and brilliance of K. ZILDJIAN cymbals as an integral part of their drum sets. For more than 300 years, K. ZILDJIAN has maintained world leadership in cymbal-making. There is no parallel, no substitute. Made exclusively in Turkey, according to the famous K. ZILDJIAN process, these are the genuine Turkish cymbals. Look for the big "K" stamped on every one. It's your CYMBAL OF PERFECTION.



K. ZILDJIAN® CYMBALS

Made in Istanbul, Turkey, by K. ZILDJIAN & CIE, for over 300 years makers of the world's finest cymbals. Why accept imitations when you can have the genuine?

K. ZILDJIAN DANCE (MEDIUM) CYMBALS

Perfectly balanced cymbals with modern high pitched sound. Smaller sizes ideal for Hi-Hats, while larger cymbals are perfect for ride and crash effects.

	EACH
X4682—K. Zildjian 12"	\$25.00
X4683—K. Zildjian 13"	29.00
X4684—K. Zildjian 14"	34.00
X4685—K. Zildjian 15"	37.00
X4686—K. Zildjian 16"	42.00
X4688—K. Zildjian 18"	52.00
X4690—K. Zildjian 20"	62.00
X4692—K. Zildjian 22"	74.00

K. ZILDJIAN BAND (MEDIUM-HEAVY) CYMBALS

Lighter weight Concert cymbals carefully matched in pairs for brilliant high sounds.

	PAIR
X4715—K. Zildjian 12"	\$50.00
X4716—K. Zildjian 13"	58.00
X4717—K. Zildjian 14"	68.00
X4718—K. Zildjian 15"	74.00
X4719—K. Zildjian 16"	84.00
X4721—K. Zildjian 18"	98.00
X4722—K. Zildjian 20"	124.00

K. ZILDJIAN SYMPHONY (HEAVY) CYMBALS

The original K. Zildjian Concert cymbals, heavy weight, matched pairs. The choice of leading Symphony Orchestras and Concert Bands throughout the world.

	PAIR
X4724—K. Zildjian 14"	\$75.00
X4725—K. Zildjian 15"	82.00
X4726—K. Zildjian 16"	94.00
X4727—K. Zildjian 18"	124.00
X4728—K. Zildjian 20"	150.00

Highly tempered and brilliant toned cymbals cannot be guaranteed against cracking.

For the new modern cymbal sound, used by jazz greats such as Art Blakey the 20" and 22" cymbals are available as Sizzle cymbals at no extra cost.

AJAHA CYMBALS FOR BAND AND ORCHESTRA



AJAHA (MEDIUM) CYMBALS

The ideal weight for crash effects. Also fine for rhythmic "tip work" and for Hi-Hat in matched pairs.

	EACH
X4738—Ajaha 12"	\$12.00
X4739—Ajaha 13"	15.00
X4740—Ajaha 14"	18.00
X4741—Ajaha 15"	20.00
X4742—Ajaha 16"	25.00
X4743—Ajaha 18"	35.00
X4744—Ajaha 20"	45.00
X4736—Ajaha 22"	60.00

AJAHA BAND (HEAVY) CYMBALS

In matched pairs for Band, Concert Orchestras and Drum Corps. Notable for their rich, brilliant tone and moderate price.

	PAIR
X4745—Ajaha 12"	\$27.00
X4746—Ajaha 13"	35.00
X4747—Ajaha 14"	41.00
X4748—Ajaha 15"	47.00
X4749—Ajaha 16"	57.00

CYMBAL ACCESSORIES FOR THE ORCHESTRA DRUMMER GRETSCH "ALL-HEIGHT" ADJUSTABLE CYMBAL HOLDER

Pioneered by Gretsch. Adjustable from 10" to 20" height. Set your cymbals to suit your style and they stay put, right where you like them. Holds the largest cymbal, firmly and safely. Complete with new Gretsch cymbal tilter, metal rocker cup, felt washers and wing-nut fastener.

With Bass Drum Shell Plate

4805—"All-Height" Cymbal Holder, Chrome \$8.50

UPRIGHT CYMBAL HOLDERS

Heavy duty upright cymbal holder with non-marring hoop clamp. With rocker cup, felt washer and wing-nut.

4810—Height 14", Nickel	\$3.00
4811—Height 14", Chrome	4.25
4812—Height 18", Nickel	3.00
4813—Height 18", Chrome	4.25
4814—Height 22", Nickel	3.00
4815—Height 22", Chrome	4.25

CYMBAL FLOOR STAND

Equipped with the new Gretsch cymbal tilter. Permits greater flexibility of set-up and accommodates extra cymbals that couldn't be fitted on the bass drum. 48" max. height; folds down in a single unit only 22½" long. Feet are rubber tipped. With felt washer and wing-nut.

4826—Cymbal Floor Stand, Chrome	\$12.00
4827—Comet Floor Stand, Chrome	12.00



CYMBAL ACCESSORIES FOR BAND AND DRUM CORPS

LEATHER CYMBAL STRAPS AND PADS

The choice of experienced band and corpsmen because they are more comfortable, more flexible than rigid hand holders and less likely to damage the cymbal cups. They protect the fingers, they allow maximum vibration—and they save your cymbals!

5830—Horse hide Cymbal Straps	Pr. \$1.20
5831—Horse hide Cymbal Pads	Pr. 2.40
5832—DeLuxe Cymbal Straps, lamb's wool covered	Pr. 3.50
5833—DeLuxe Cymbal Pads, lamb's wool covered	Pr. 6.00

CYMBAL HAND HOLDERS

Standard model with plain wood handles and adjustable hand straps. Complete with felt and leather washers.

5825—Standard Cymbal Hand Holders	Pr. \$2.25
Deluxe model with lamb's wool padded grip. Complete with adjustable leather thongs and felt and leather washers.	
5827—Deluxe Cymbal Hand Holders	Pr. \$6.00

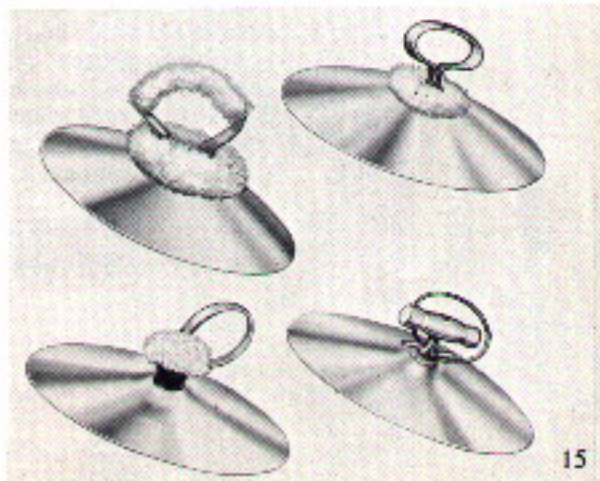

GRETSCH

DRUM PEDALS

GRETSCH "FLOATING ACTION" BASS DRUM PEDAL

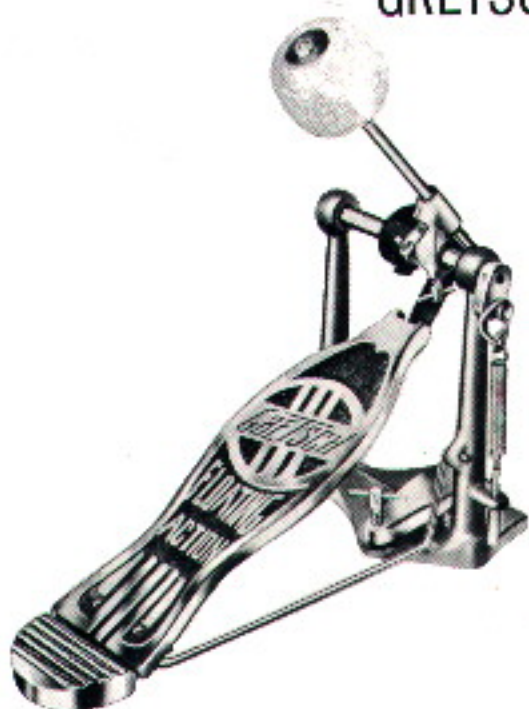

Lightning fast... and smooth! No wonder top professionals by the hundreds are equipping with this new pedal. Just check these "Floating Action" features:

- Improved ball bearings with lifetime lubrication sealed in
- Unique stroke length regulator for effortless, perfectly balanced stroke (adjustable to suit player)
- Positive spring adjustment regulates action to suit you
- Hinged foot plate—extra wide for greater, surer foot contact
- Made of high-test aluminum alloys for maximum strength, minimum weight
- Folds in one piece for quick and easy pack-up
- Felt beater ball for that quick, solid thud-tone modern drumming techniques demand
- Gray Lacquered double-post aluminum alloy frame; other parts brightly polished

4955—GRETSCH "Floating Action" Pedal \$23.50

PROFESSIONAL DRUM PEDAL—DOUBLE POST MODEL

Hardened steel pivot bearings packed in graphite and alemite for fast action. Adjustable spring tension. Folds in one piece for quick and easy pack-up. Felt beater ball, hinged foot plate. Black crystallized Lacquer frame; other parts polished.

4956—Professional Drum Pedal \$19.00

GRETSCH "SPEED-EE" PEDAL

Sturdy, high speed pedal at a minimum price. Fold compactly. Laminated felt ball; comfortable foot plate. Nickel plated.

4950—"Speed-ee" Pedal \$8.00

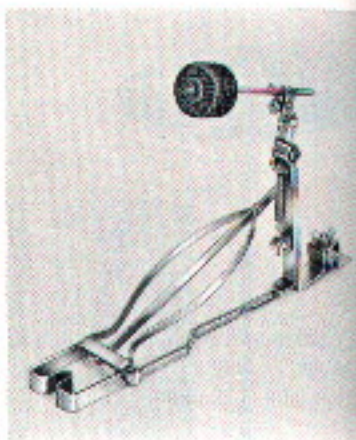

HI-HATS

GRETSCH "FLUSH BASE" ADJUSTABLE HI-HAT PEDAL

Sets up or takes down in seconds—folds in one piece. Space-saving flush base stands firmly on rubber-tipped, non-vibrating feet. Smooth, fast, noiseless action. Adjusts from 29" to 37". New cymbal clutch device enables quick removal (or set-up) of cymbals. (Cymbals not included.) Chrome plate.

4844—Gretsch "Flush Base" Adjustable Hi-Hat Pedal, Chrome. \$22.50

GRETSCH "DIRECT PULL" ADJUSTABLE HI-HAT PEDAL

Direct pull gives smoothest, fastest pedal action. Folds in 1 piece. Adjustable from 29" to 37". Extra-wide foot board. New convenient cymbal clutch. Measurements and weight same as the 4844. Chrome plate.

4845—Gretsch "Direct Pull" Hi-Hat Pedal, Chrome. \$22.50



GRETSCH LATIN AMERICAN

RHYTHM INSTRUMENTS — AUTHENTIC STYLES



4497

"Pro" Bongo. Adjustable calf heads with beautiful finish of solid Redwood. Chrome plated metal parts: clamps give accurate tone control.

4497 — Head sizes 6½" and 5" **\$33.50**

Redwood Bongo. Tension drawn calf heads over natural Redwood shell. Authentic tone quality.

4495 — Head sizes 6½" and 4¾" **\$19.20**

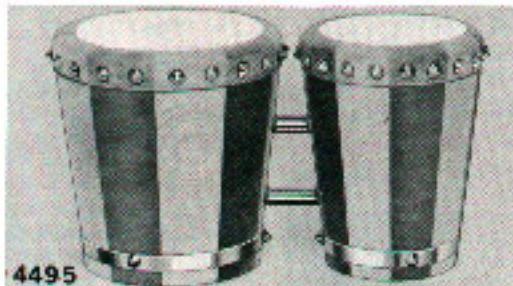

4495

Economical Bongos. Calf heads tension drawn over Redwood and hard Pine shells. Authentic tonal quality. "Brass tacks" add authentic look.

4498 — Head sizes 5" and 4" **\$11.00**

4499 — Two-tone Walnut and Birch, head sizes 5¾" and 3¾" **9.50**



4498



4499

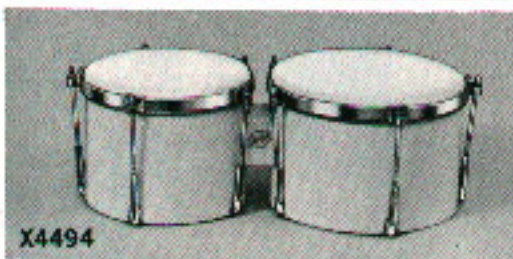

X4494

GRETSCH TUNABLE BONGOS AT TODAY'S LOWEST PRICE

X4494—Authentic in tone, completely tunable, and priced hardly higher than ordinary non-tunable bongos. Set of two, 8" x 5½" and 7" x 5½" molded plywood shells. Nickel plated counter hoops and tension rods. Polished Lacquer finish in White, Blue or Red

..... **\$36.00**

GRETSCH TUNABLE BONGOS

Set of two, shell sizes 8" x 5½" and 6" x 5½" mounted on sturdy block holder. Shells are "perfect round" molded plywood. Streamlined tension casings and self-seating, self-aligning



X4492

rods; metal counterhoops pull down below head-level to give unobstructed top surface.

All Metal parts Chrome plated.

X4490—Tunable Bongos in polished White or Ebony Lacquer (other colors to order) and Chrome Set **\$58.00**

X4492—Tunable Bongos in GRETSCH-PEARL and Chrome Set **66.00**

FINE QUALITY GRETSCH MARACAS

Superbly finished, imported Maracas with crisp, resonant tone.

4885—GRETSCH Standard Maracas; stenciled design Pr. **\$4.00**

4886—GRETSCH Deluxe Maracas; hard-carved Pr. **\$4.50**

GRETSCH DELUXE CLAVES

4894—Extra large (7¾" long) turned from finest Mexican rosewood and highly polished. Extra resonant in tone Pr. **\$3.30**

GRETSCH KAM-E-SO (SHAKER)

A flashy addition to your Latin-American percussion equipment. It's a large Gourd, hand carved, tinted and highly polished. Held in both hands, it is shaken to produce a maraca-like tone. Average length, 13".

4899—GRETSCH Kam-e-so (or Shaker) **\$5.25**

GRETSCH DELUXE GUIRO

Hand carved, hand tinted, highly polished Mexican Gourd with serrations against which is rubbed a hand turned scraper. Average length, 13".

4897—GRETSCH Deluxe Guiros with Scraper **\$5.25**

FREE CHART

Every drummer needs the new GRETSCH chart giving authentic rhythm beats for Rhumba, Samba, Guaracha and Mambo. In score form for complete Latin-American instrumentation. No charge.



4886

4885

4894

4897

4899

GRETSCH DRUM COVERS & CASES

GRETSCH DELUXE MACKINTOSH DRUM COVERS

Made of heavy, close-textured, water-repellent brown duck, rubberized to plaid flannel lining for utmost protection against dust, moisture and temperature changes. Double stitched seams and self-strap for carrying. Super-tailored for fine fit.



COVERS FOR ORCHESTRA SNARE DRUMS

- 5038—For shell, 13"x3½"; zipper closure... \$7.95
- 5039—For shell, 14"x4"; zipper closure... 7.95
- 5040—For shell, 14"x5½"; zipper closure... 7.95
- 5041—For shell, 14"x6¾"; zipper closure... 7.95
- 5044—For shell, 15"x8"; zipper closure... 7.95

COVERS FOR PARADE SNARE AND TENOR DRUMS

- 5043—For shell, 14"x10"; zipper closure... \$8.50
- 5046—For shell, 15"x12"; zipper closure... 8.75
- 5047—For shell, 16"x12"; zipper closure... 9.00
- 5048—For shell, 18"x12"; zipper closure... 9.75

TUNABLE TOM TOM COVERS

- 5049—For shell, 12"x8"; zipper closure... \$8.25
- 5050—For shell, 13"x9"; zipper closure... 8.50
- 5051—For shell, 14"x14"; zipper closure... 9.00
- 5052—For shell, 16"x16"; zipper closure... 9.50
- 5053—For shell, 18"x16"; zipper closure... 10.00

BASS DRUM COVERS (ZIPPER CLOSING)

No.	For Shell		No.	For Shell	
5070	18"x14"	\$13.50	5062	28"x10"	\$16.00
5054	20"x14"	13.50	5063	28"x12"	16.25
5055	22"x14"	13.50	5064	28"x14"	16.25
5056	24"x12"	14.25	5065	30"x10"	17.00
5057	24"x14"	14.25	5067	30"x12"	17.00
5058	26"x7"	15.00	5068	30"x16"	17.25
5060	26"x14"	15.25	5069	32"x16"	18.00
5061	28"x8"	16.00			



Gretsch drum and tom tom cases are made of genuine VULCANIZED black fibre—the toughest, strongest material you can buy. Gives long service and utmost protection.



CARRY-ALL SNARE DRUM AND TRAP CASE

Vertical type with removable tray for traps and cymbals. Holds snare drums up to 15" x 8" shell. Made of finest quality, genuine vulcanized black fibre. Leather straps, leather covered handle, and Nickel plated hardware.

- 5080—Snare Drum and Trap Case... \$27.95B
- 5083—Deluxe Trap Case, same as above but, holds up to 20" cymbal (not illus.)... \$37.50B



SUIT CASE STYLE DRUM AND TRAP CASE

With adjustable partition to take any orchestra or band snare drum up to 15" x 8" shell. Finest quality vulcanized black fibre over hardwood frame. Tray for cymbals and traps with extra storage space beside the drum. Two trunk clasps and lock; leather covered handle.

- 5081—Snare Drum and Trap Case... \$29.75B



Telescopic style, flat bottom model (stands solidly, won't roll) cases made of finest quality vulcanized black fibre. Leather covered handle; heavy leather strap with buckle.

FLAT-BOTTOM, TELESCOPIC BASS DRUM CASES

- 5094—Bass Drum Case for 20"x14" shell... \$32.50B
- 5099—Bass Drum Case for 22"x14" shell... 33.00B
- 5095—Bass Drum Case for 24"x14" shell... 33.50B
- 5096—Bass Drum Case for 26"x14" shell... 34.25B
- 5097—Bass Drum Case for 28"x14" shell... 34.75B
- 5098—Bass Drum Case for 30"x16" shell... 37.50B

FLAT-BOTTOM, TOM TOM AND PARADE DRUM CASES

- 5085—Tom Tom Case, for 12"x8" shell... \$15.00B
- 5086—Tom Tom Case, for 13"x9" shell... 15.75B
- 5087—Tom Tom Case, for 14"x14" shell... 19.00B
- 5088—Tom Tom Case, for 16"x16" shell... 19.75B
- 5089—Tom Tom Case, for 18"x16" shell... 24.50B
- 5090—Parade Drum Case, for 14"x10" shell... 16.75B
- 5091—Parade Drum Case, for 15"x12" shell... 18.25B
- 5092—Parade Drum Case, for 16"x12" shell... 19.00B
- 5093—Parade Drum Case, for 18"x12" shell... 22.50B



STANDARD BASS SLING

Extra heavy 2" webbing, with three Nickel plated hooks and two Nickel plated adjusting slides.

- 5862—Standard Bass Drum Sling, Khaki... \$2.50
- 5863—Standard Bass Drum Sling, White 2.50



PARADE DRUM SLING

Finest 2" extra heavy webbing, adjustable for length. Has heavy duty, cast swivel snap with integral hook-eye that hangs drum in natural position.

- 5850—Parade Snare or Tenor Drum Sling, Khaki... \$2.00
- 5851—Parade Snare or Tenor Drum Sling, White... 2.00

BASS DRUM SLING

Heavy duty model. Shoulder straps are 2" highest grade Khaki or White webbing. Designed to distribute the weight of the drum over the back and shoulders. Adjusting straps are extra heavy 1" webbing, adjustable at two points. Snaps are new heavy duty cast type.

- 5860—Heavy duty Bass Drum Sling, Khaki \$4.50
- 5861—Heavy duty Bass Drum Sling, White 4.50



PARADE DRUM LEG REST

A useful and practical accessory for the parade snare or tenor drummer. Holds the drum securely so that it rises and falls with the movement of the leg, reducing fatigue and eliminating bruises. Folds back against the drum for compact fit in drum cover or case. Chrome plated finish; new improved model attaching to the tension rods by clamps and wing nuts. No disfiguring of the drum shell.

- 5885—Leg Rest, Chrome rod mount \$6.75
- 5886—Leg Rests, Chrome shell mount 6.75

GRETSCH DRUM ACCESSORIES



DRUMMERS' THRONE

New playing convenience and comfort. Revolving seat is padded, upholstered. Adjusts to any height, folds compactly. Nickel plated.

4990—Drummers' Throne, without back rest . . . \$17.50

4992—Drummers' Throne, with back rest (illustrated) . . . \$19.00



DRUMMERS' THRONE

4991—Revolving non-slip piano stool type adjustments. Heavy duty construction, foam rubber padded seat. Adjusts to any height, folds compactly. Polished Chrome base. \$24.00



BUCK ROGERS DRUM STAND

Solid new grip makes drum and stand like one unit. Heavy construction; won't budge, even under rim shots. Folds compactly. Chrome plate.

4986—Buck Rogers Drum Stand, Chrome \$21.00



HEAVY DUTY DRUM STAND

Heavy duty, professional drum stand holds drum firmly. Rubber tipped feet cling to any floor. Rubber covered arms protect drum from marks. Fully adjustable; folds compactly. Chrome plate.

4983—Heavy Duty Drum Stand, Chrome \$10.50



STUDENT DRUM STAND

Good weight steel, Nickel plated. Stands firmly and holds drum securely. Folds compactly; takes drums 13" to 15".

4980—Student Drum Stand, \$5.50



BASS DRUM STAND

Holds drum securely and won't rattle or creep. Padded, non-marring drum rest. Adjustable in height. Folds for carrying. With strap.

4989—Bass Drum Stand \$19.50

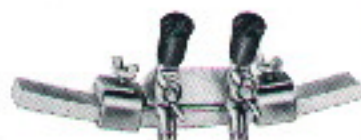

BASS DRUM FLOOR HOLDER

Braces the bass drum against the pedal stroke and keeps it from sliding backwards. Reversible pointed and rubber tips.

4971—Bass Drum Floor Holder \$4.50



DRUMMERS' WOOD BLOCK

Well seasoned hardwood, slotted top and bottom for crisp, clear tone. Fits all standard holders.

X4900—Wood Block, 6 3/4" \$2.50

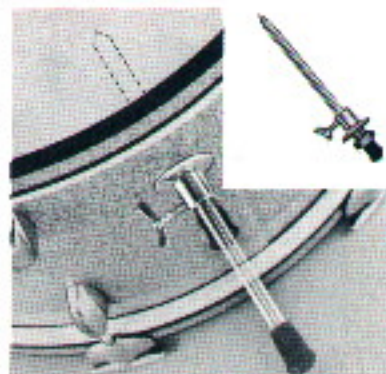

DISAPPEARING BASS DRUM SPURS

To pack up, just loosen the thumb screw and push the spurs back into the shell. Setting up is just as quick—a mere matter of seconds. Self-locking washer holds the rod-housing securely. Over-size spur rods of polished aluminum alloy; rubber tips.

4960—GRETSCH Disappearing Bass Drum Spurs. . . Pr. \$6.00

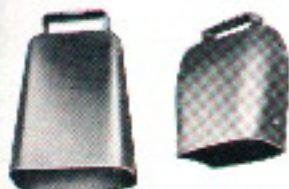

DRUMMERS' COWBELLS

4905—Cowbell, size 3 1/2" \$1.50

4906—Cowbell, size 4 3/8" 1.75

4907—Cowbell, size 5" 2.00

4908—Cowbell, size 6 1/2" 2.50

For Chrome finish, add 1.50

The new Gretsch cowbell. The authentic cowbell sound is back.

4917—Cowbell, size 3" \$3.00

4918—Cowbell, size 3 1/2" 4.00

4919—Cowbell, size 4" 5.00

4920—Cowbell, size 5" 6.50



4910

COWBELL & WOOD BLOCK HOLDER

Holds wood block and two cowbells of any size in most convenient playing position. With hoop clamp. Nickel plated.

4910—Wood Block & Cowbell Holder \$3.75

SINGLE HOLDERS

Nickel plated, with hoop clamp.

4911—Wood Block Holder (single) not illus. \$1.00

4912—Cowbell Holder (single) 1.50

4916—U-Clamp only for cowbell holder30



4916

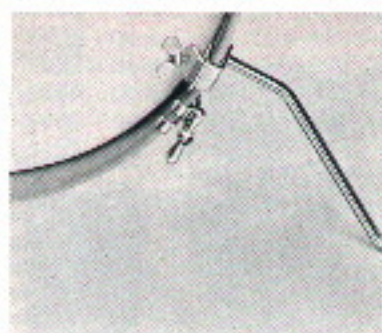

GIANT BASS DRUM SPURS

Popular priced, over-size spurs that attach high on the hoop and hold drum solidly in place. Nickel plated, Spur rod is pointed with removable rubber tips.

4964—Giant Spurs. . Pr. \$2.50



ECONOMY BASS DRUM SPURS

Nickel plated steel with pointed ends.

4968—Economy Spurs Pr. \$1.50

GRETSCH HARDWARE & ACCESSORIES



4977 - Felt Beater Ball	\$2.50	5163 - Strap Screw	.05
5150 - Hoop Clamp	.85	5164 - Cam Casting	1.25
5151 - Hoop Clamp		5165 - Beater Hub	
Screw	.40	Casting	1.25
5156 - Hub Lock Screw	.35	5166 - Foot Board	8.00
5157 - Beater Lock		5167 - Hex Shaft	
Screw	.35	Assembly	2.75
5158 - Spring	.25	5168 - Frame Assembly	6.00
5159 - Spring Rocker	.30	5169 - Metal Heel Plate	
5160 - Spring Screw	.15	Hinge	.45
5161 - Spring Lock Nut	.15	5170 - Heel Plate	1.25
5162 - Cam Strap	.50	5171 - Radius Rod	
		Assembly w/clamp	1.75

GRETSCH "MICRO-SENSITIVE" SNARE STRAINER

Now! A fast, positive throw-off that's quiet and cannot slip. Really professional and, we think, the finest snare strainer yet developed. Used by everyone—jazz drummers, concert hands and drum corps. Unusual in its dual-tension adjustment—one for close tuning on the strainer itself, one with faster action on rear snare bracket. Housed in modern die-cast casing, finished in brilliant Chrome.

- 5380 - GRETSCH "Micro-Sensitive" Throw-Off Snare Strainer and Snare Bracket, Chrome Complete \$15.00
 5381 - GRETSCH fast-tension Snare Bracket (only as supplied with 5380 "Micro-Sensitive" Strainer, Chrome 4.00

GRETSCH "RENOVN" THROW-OFF STRAINER

Dependable and quiet in action. Complete with rear snare bracket. Chrome plated.

- 5385 - "RENOVN" Throw-Off Strainer & Bracket \$4.00
 5386 - Rear Snare Bracket (only) 1.00

GRETSCH PARADE DRUM SNARE STRAINERS

- 5393 - Parade Drum Strainer (non-throw-off) complete with No. 5386 rear snare bracket, Chrome 3.50

DRUM SLING ACCESSORIES

- 5875 - Soap-eye for metal hoop, Chrome \$.35
 5879 - D-Ring for wood hoop, Chrome75
 5881 - Bass Drum Carry Ring, complete, Chrome50

MISCELLANEOUS DRUM HARDWARE & ACCESSORIES

- 4822 Wing Nut, 1/4", Chrome for cymbal holders (top) \$.15
 4961 Wing Screw, 1/4", Chrome, as on cymbal holder 4805 and Disappearing Spurs 496040
 4941 Wing Screw, 1/4" with shoulder, Chrome, for Tom Tom Holder Hoop clamps (as on 4935 and 4940)50
 4933 Wing Screw, 3/8", Chrome, for Cymbal Holder Shell Plates, Tom Tom Leg Brackets, Spurs 4962, etc. \$.50
 4963 Thumb Screw, 1/4" Chrome, for 5435 Bass Drum Muffler and 4962 Spurs50
 4820 Diamond Plate for 4805 Cymbal Holder, Chrome 3.00
 4821 Hi-Hat Clutch Assembly 2.00

- 4944 Key, Rail Consolette, Chrome60
 4832 Cymbal Washers, Felt .. .10
 5540 Tone control for Snare Drum or Tom Tom with twin head mulling surface and extra large Chrome control knob .. 4.00
 8849 Rubber Feet, (Standard Size), for Music Stand, Drum Stand or High-Hat10
 4993 Rubber Feet, (Extra Large), for Drummers' Throne15

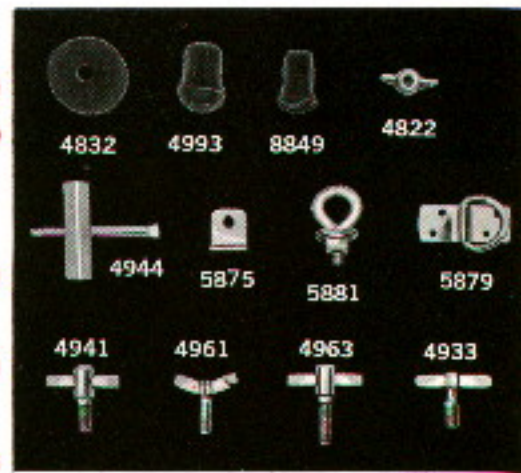
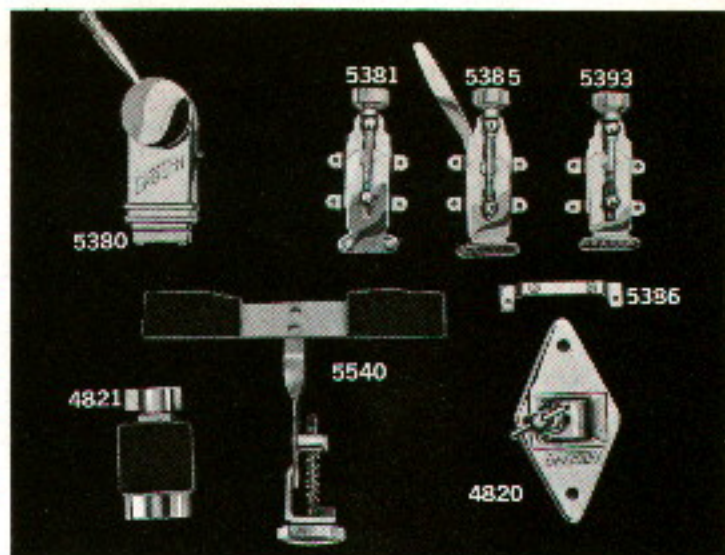

GRETSCH "RESPONSO" SNARES

Every strand lies flat and hugs the head to give instant response. Bright Nickel plated finish.

- 5414 - "Responso" 12 strand snares for 14" drum Set \$3.00
 5415 - "Responso" 12 strand snares for 15" drum Set 3.00
 5416 - "Responso" 16 strand snares for 14" drum Set 3.50
 5417 - "Responso" 16 strand snares for 15" drum Set 3.50
 5420 - "Responso" 16 strand snares for 16" drum Set 3.50
 5418 - "Responso" 20 strand snares for 14" drum Set 4.00
 5419 - "Responso" 20 strand snares for 15" drum Set 4.00
 5412 - "Power" 42 strand snares for 14" drum Set 10.00

GUT AND SILK-WIRE WOUND SNARES

To fit drums 13" to 16" shell diameter. Made up in 12 strand sets with fibre snare butt,

- 5422 - Gut Snares, med. gauge for orchestra drum Set \$4.50
 5423 - Gut Snares, heavy gauge for concert or parade Set 5.00
 5410 - Silk Snares, silvered wire wound Set 1.25

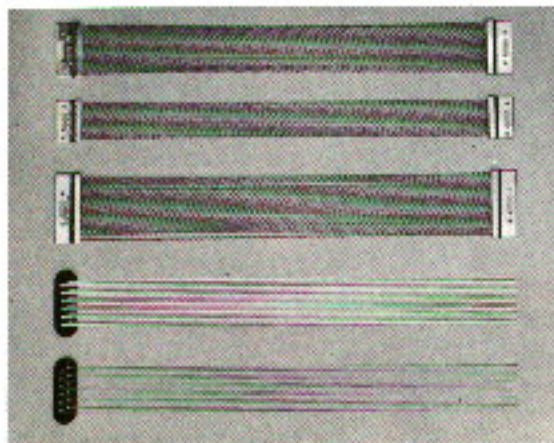

GRETSCH HARDWARE & ACCESSORIES

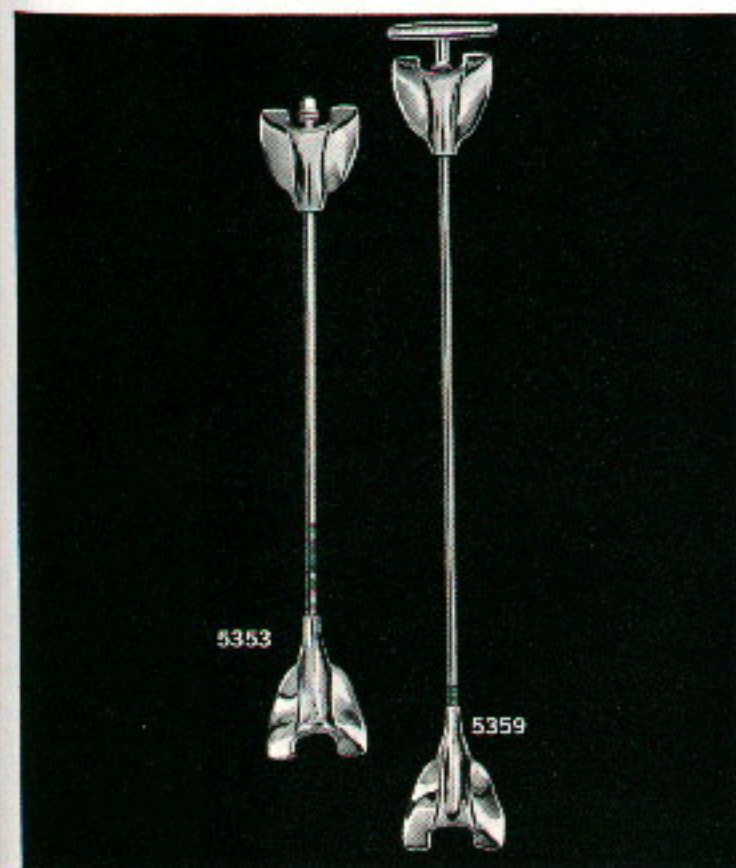
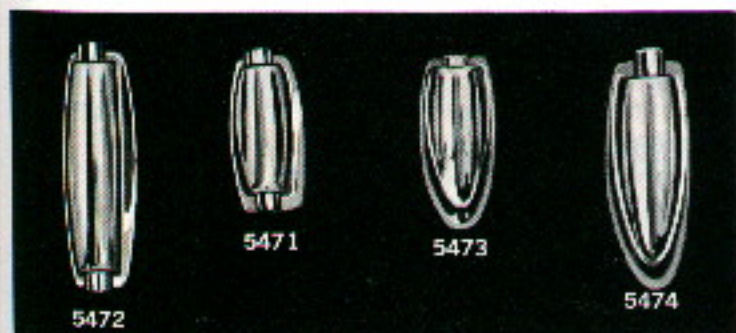

DRUM ROD CASINGS (LUGS) AND ACCESSORIES

When ordering rods please be sure to order by number and also state the length wanted, measuring from under the collar or handle.

- 5472 - Die-cast Tension Rod Casing Double End with screws and washers, Chrome. For snare drums with spring & inserts **\$1.30**
- 5471 - Die-cast Tension Casing for Progressive Jazz Snare drum with spring and inserts **\$1.30**
- 5473 - Die-cast Tension Rod Casing Single End with screws and washers. For separate tension orchestra or concert snare drums and small tom toms. Chrome, with spring & inserts **1.30**
- 5474 - Die-cast Tension Rod Casing Single End with screws and washers. For separate tension parade snare drums, bass drums and large tom toms. Chrome, with spring & inserts **1.30**
- 5469 - Snare Drum Rod Center Post with screw and washers, Chrome **.40**
- 5470 - Bass Drum Rod Center Post, with screw and washers, Chrome **.40**

COMPLETE DRUM ROD ASSEMBLIES

Key Rods for Snare, Tenor and Bass Drums
Each complete with double claw hooks and rod washers

- 5351 - For 7" shell, Chrome **\$1.90**
 - 5352 - For 8" shell, Chrome **1.90**
 - 5353 - For 10" shell, Chrome **1.90**
 - 5354 - For 12" shell, Chrome **1.90**
(Center posts 40¢ extra; specify for snare or bass drum)
- Tympani Handle Rod Assembly for Single Tension Bass Drums
- 5358 - 12" shell; double claw hooks, Chrome **\$2.30**
 - 5359 - 14" shell; double claw hooks, Chrome **2.30**
(Center posts 40¢ extra)

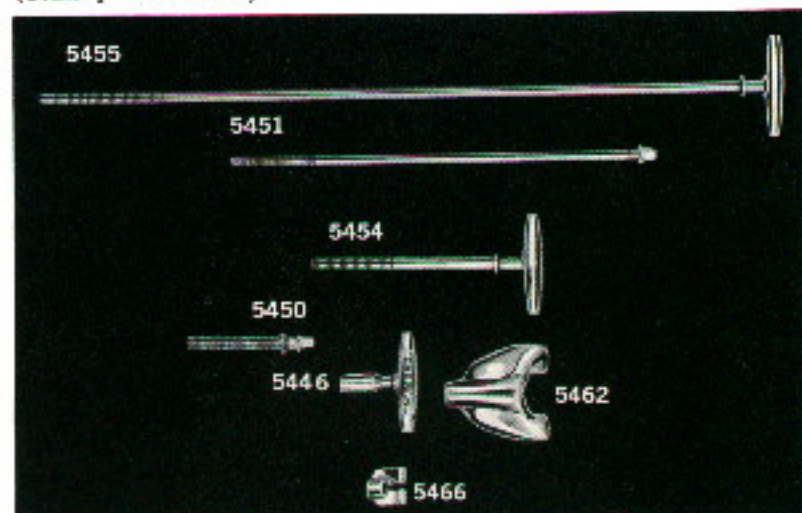

GRETSCH HOOPS

Gretsch Rock Maple Molded Plywood Drum Hoops

Perfect Round Guaranteed!

(Specify Snare or Batter Side, and Outside Diameter of Shell)

No.	For Shell Diameter	Finish	
5611	12" to 18"	Clear Lacquer	\$2.50
5612	12" to 18"	Colored Lacquer	2.50
5613	12" to 18"	Col. Lac., Pearl-Inlaid	4.50
5619	20" to 30"	Clear Lacquer	4.00
5620	20" to 30"	Colored Lacquer	5.00
5621	20" to 30"	Col. Lac., Pearl-Inlaid	7.50
5626	12" to 18"	3-Ply	.75
5628	20" to 30"	3-Ply	2.50

Fully Flanged Die-Cast Hoops

with Beaded Edge for Snare Drum & Tom Toms

(Specify Snare or Batter Side, and Outside Diameter of Shell)

5485	12" shell, Chrome	\$ 7.00
5486	13" shell, Chrome	8.00
5487	14" shell, Chrome	8.00
5488	15" shell, Chrome	8.00
5489	16" shell, Chrome	9.00
5490	18" shell, Chrome	10.00
5491	14" shell, Chrome, for 6 lug drum	7.50
5638	Hoop, Single Flange, 14" shell, Chrome	5.25
5640	Hoop, Plain Steel (no flange) for shells 14", Chrome	2.65

GRETSCH DRUM RODS AND HOOKS

(Rod lengths are measured from below the collar or handle. Specify length.)

- 5446 - Drum Key, Chrome **.50**
- 5447 - Snap-in Drum Key Holder, Chrome (not illustrated) **.50**
- 5450 - Drum Rods, Square Head; 13½", 15½", 21¼", 23¼", 43¼", 51½" and 6", Chrome **.50**
- 5451 - Drum Rods, Square Head; 8¾", 10¾", 12¾", Chrome **.60**
- 5454 - Drum Rods, Tympani Handle; short, for sep. ten., Chrome .. **1.00**
- 5455 - Drum Rods, Tympani Handle; long, for single ten., Chrome **\$1.25**
- 5462 - Double Claw Hooks; not threaded, Chrome **.60**
- 5463 - Double Claw Hooks; threaded, Chrome **.70**
- 5466 - Rod Collars (books) for metal hoops, Chrome **.30**
- 5467 - Rod Collars (books) for metal hoops, with threaded inserts, Chrome (not illustrated) **.40**

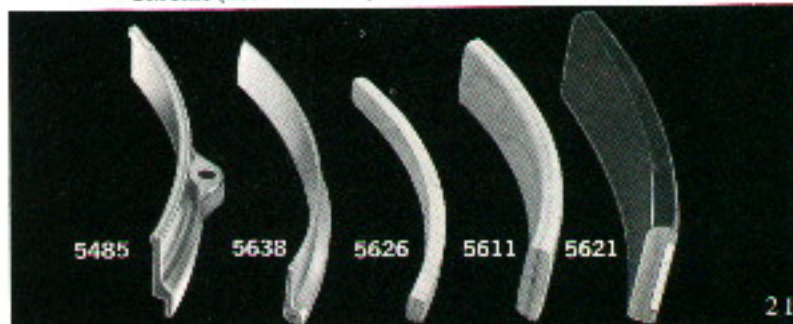

GRETSCH SNARE DRUM STICKS

Expect this from Gretsch sticks: uniformity of model, balance, and playing qualities. Such consistent high calibre of Gretsch sticks is the result of careful stock selection, perfect turning, and glassy-smooth finish. Only the finest second-growth, straight-grained white hickory stock may be used . . . and this must be sci-

entifically and thoroughly seasoned before turning to insure perfect straightness. Step by step, Gretsch's attention to details is your assurance that your favorite stick will always be the same. There's a model exactly suited to your needs.

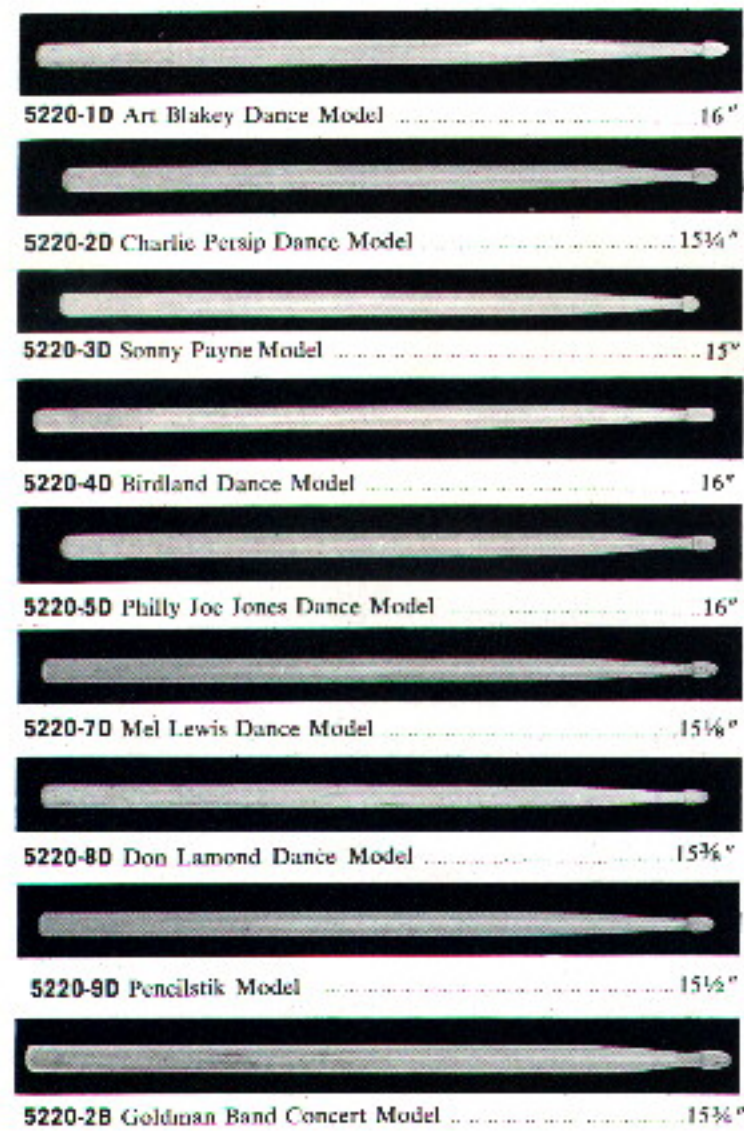

GRETSCH SNARE DRUM STICKS (All Models) Pr. \$1.20

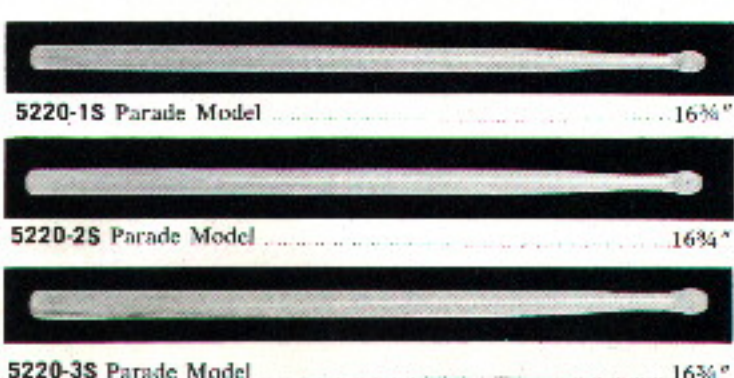

1D Art Blakey — Good, all-round model for big band or small group. Ideally suited for ride cymbal work.

5D Philly Joe Jones — Medium weight, long model, designed by Philly Joe, one of the most progressive jazz drummers today, for fast work between snare, tom tom and cymbals.

7D Mel Lewis — Very light dance stick used by Lewis and many others. Ideal for top cymbal work and left hand independent snare drum beats.

8D Don Lamond — Similar to the 7D in weight but slightly longer. A "fast" model, very popular with drummers who play "Up-Tempo" numbers.



GRETSCH WIRE DRUM BRUSHES

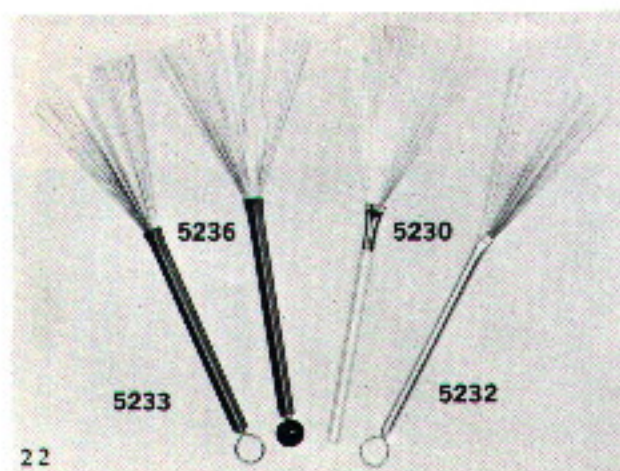

Made of finest quality, rust-resisting piano wire evenly spread and securely mounted. Correctly balanced.

5230—Non-telescoping wire brushes with Lacquered wood handles correctly balanced for easy playing Pr. **\$1.05**

5232—Telescoping wire brushes with loop ends and polished metal handles; professional grade Pr. **\$1.50**

5233—Telescoping wire brushes with loop ends and ribbed rubber covered handles; professional quality Pr. **\$1.75**

5236—Telescoping wire brushes with hard rubber ball ends and ribbed rubber covered handles; deluxe quality Pr. **\$1.85**

GRETSCH TYMPANI STICKS

5253—All-purpose model with solid Spanish felt heads, good for rhythm work on Tympani, Tom Tom and Cymbals. Extra long, full tapered handles...Pr. **\$4.50**

5255—Conventional lamb's wool covered heads; extra long, full tapered handles. Produces a rich full tone...Pr. **\$6.50**

5258—Phil Grant Professional Model with small Spanish felt currawheel covered with hand-sewn, finest piano felt. Fast action and clear rich tone. Extra long full tapered handles for better leverage, finer balance, greater playing ease...Pr. **\$5.00**

5261—Professional model with large Spanish felt currawheels covered with hand-sewn, finest piano felt. Extra long, full tapered handles. Produces a big resonant tone of pleasing quality with minimum effort; particularly valuable for school band or orchestra...Pr. **\$6.00**

GRETSCH BASS DRUM STICKS

5328—Genuine "Gus Helmecke" Bass Drum Stick. Extra long polished hickory handle with finest quality piano felt ball at each end. Wonderful balance and tone production make this ideal for the concert artist...Ea. **\$6.00**

5330—A perfect stick for concert or marching bands and drum corps. Finest piano felt covered ball over extra resilient core. Polished hickory handle with leather thong to assist "swings" and reduce fatigue...Ea. **\$6.25**

5332—Single end model with fine piano felt covered ball over resilient core. Produces short, natural tones. Perfectly balanced for band or drum corps...Ea. **\$5.25**

5334—E-Z grip stick for heavy duty. Hickory handle with comfortable lamb's wool grip and leather thong that assists full, free swings without tiring hand or wrist. Laminated Spanish felt ball gives big tone with little effort...Ea. **\$6.50**

5337—Single end model. Laminated Spanish felt ball gives big tone. Natural hickory handle. Maximum service and durability. Ea. **\$3.95**

SCOTCH BASS & TENOR DRUM STICKS

5315—Scotch Bass Drum Sticks with lambs' wool covered ball over felt and cork. Produces fine sustained tone and perfect for twirling. Hickory handles with ball ends and leather thongs. Pr. **\$7.95**

5317—Scotch Bass Drum Beaters with laminated Spanish felt balls. Hickory handles with ball ends and leather thongs. Balanced for easy twirling...Pr. **\$7.50**

5306—Tenor Drum Sticks with lambs' wool covered balls over felt and cork. Hickory handles with ball ends and leather thongs. For soft sustained tone. Pr. **\$7.50**

5309—Tenor Drum Sticks with laminated Spanish felt balls; hickory handles with ball ends and leather thongs. Good solid tone and perfect twirling balance...Pr. **\$6.95**

GRETSCH XYLOPHONE MALLETS

Precision molded hard rubber heads, 1" diameter; selected rattan handles. While generally used for xylophone, many players prefer the $\frac{3}{4}$ -hard mallet for orchestra bells because of their more mellow tone.

5270—Xylophone Mallets, $\frac{3}{4}$ -hard rubber...Pr. **\$2.00 B**

5271—Xylophone Mallets, $\frac{1}{2}$ -hard rubber...Pr. **2.00 B**

5272—Xylophone Mallets, $\frac{3}{8}$ -hard rubber...Pr. **2.00 B**

GRETSCH BELL OR GLOCKENSPIEL MALLETS

"Click-less" ivory plastic 1" ball; selected rattan handle. Produces maximum volume and resonance of tone, especially suited for large auditoriums or out-door playing, etc. full-

5276—Bell Mallets, full-hard plastic head...Pr. **\$2.50 B**

YARN-WOUND "VIBE" OR MARIMBA MALLETS

Finest wool yarn-wound over cores of graded hardness. Handles are best quality, resilient rattan. Fine balance and excellent tone production explain their widespread popularity among professional players.

5280—Vibe Mallets, blue yarn, med. hard. Pr. **\$3.50 B**

5281—Vibe Mallets, yellow yarn, med. soft...Pr. **3.50 B**

5282—Vibe Mallets, gray yarn, soft...Pr. **3.75 B**

PROFESSIONAL PRACTICE PAD

STUDENT PRACTICE PAD

Size, 4" x 4½" x ½" with genuine gum rubber giving fast, smooth, drum-like response. Hardwood, Red Lacquer finished.

5809—Student Practice Pad...Pr. **\$2.50**

"Tri-Spot" model with 6" center pad and two auxiliary pads of lively, resilient pure gum rubber, facilitating practice of snare drum and tom tom routines. Heavy hardwood, in Blue Lacquer; four rubber feet prevent creeping.

5811—"Tri-Spot" Practice Pad...Pr. **\$5.25**

4984—Heavy Duty Practice Pad Stand...Pr. **\$7.50**

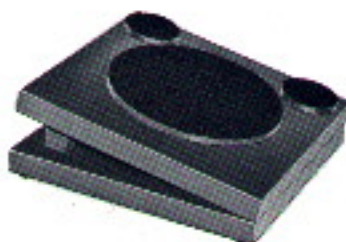
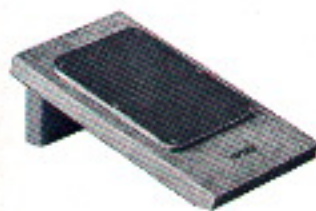

GRETSCH

DRUM HEADS

FINEST QUALITY CALFSKIN HEADS

Only select skins—the very best of the great Chicago hide market are chosen for GRETSCH Drum heads. These perfect skins, in the hands of skilled craftsmen, become the heads critical drummers demand: durable, rich and full in tone, and quick to respond.

WHITE CALF BATTER HEADS FOR SNARE DRUM

	Un-Mounted	Mounted*
5507—Size, 17" for 13" Drum	\$ 7.55	\$ 8.80
5508—Size, 18" for 14" Drum	8.25	9.50
5509—Size, 19" for 15" Drum	9.25	10.50
5510—Size, 20" for 16" Drum	10.25	11.50
5512—Size, 22" for 18" Drum	11.50	12.75

TRANSPARENT SNARE HEADS FOR SNARE DRUM

	Un-Mounted	Mounted*
5567—Size, 17" for 13" Drum	\$6.25	\$7.50
5568—Size, 18" for 14" Drum	6.75	8.00
5569—Size, 19" for 15" Drum	7.25	8.50
5570—Size, 20" for 16" Drum	7.75	9.00

* Expertly Factory Tucked on Gretsch Exclusive 3-ply laminated Flesh Hoop

** Expertly Factory Tucked on your Flesh Hoop

WHITE CALF TOM TOM HEADS

	Un-Mounted	Mounted*
5600—Size, 16" for 12" Tom Tom	\$ 7.00	\$ 8.25
5601—Size, 17" for 13" Tom Tom	7.55	8.80
5602—Size, 18" for 14" Tom Tom	8.25	9.50
5603—Size, 20" for 16" Tom Tom	10.25	11.50
5604—Size, 22" for 18" Tom Tom	11.50	12.75

WHITE CALF BASS DRUM HEADS

	Un-Mounted	Mounted*
5522—Size, 22" for 18" Drum	\$16.25	\$18.50
5524—Size, 24" for 20" Drum	\$18.75	\$21.00
5526—Size, 26" for 22" Drum	20.25	22.50
5528—Size, 28" for 24" Drum	21.55	23.80
5530—Size, 30" for 26" Drum	23.55	25.80
5532—Size, 32" for 28" Drum	25.25	27.50
5534—Size, 34" for 30" Drum	27.75	30.00
5536—Size, 36" for 32" Drum	33.75	36.00

TRANSPARENT TYMPANI HEADS

	Un-Mounted	Mounted**
5580—Size, 30" for 24" Tympani	\$31.00	\$33.50
5581—Size, 31" for 25" Tympani	32.00	34.50
5582—Size, 32" for 26" Tympani	32.50	35.50
5583—Size, 33" for 27" Tympani	33.50	36.50
5584—Size, 34" for 28" Tympani	34.50	37.50
5585—Size, 35" for 29" Tympani	35.50	38.50
5586—Size, 36" for 30" Tympani	36.50	39.50

WHITE CALF BONGO HEADS

5574—Bongo Head mounted on 6" square metal flesh hoop	\$3.50
5576—Bongo Head mounted on 7" square metal flesh hoop	4.00
5575—Bongo Head mounted on 8" square metal flesh hoop	4.50

PERMA-TONE (Plastic) DRUM HEADS

You NEVER have to tension heads in humid or rainy weather. Let it rain! Gretsch Perma-Tone heads are unaffected by weather. Once head is set, no further tensioning needed. Drums always sound crisp. Ideal for outdoor concerts and marching bands. Perma-Tone heads are long-lasting, of even thickness throughout, comparable in feel and response to calfskin. Mounted on metal flesh hoops.

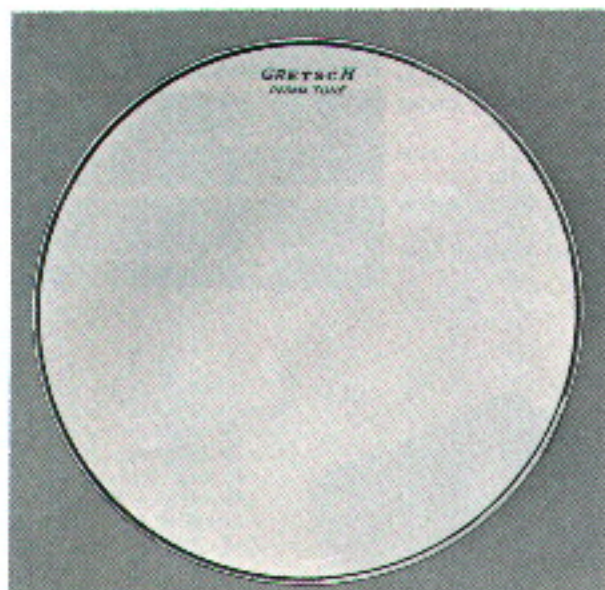

BATTER HEADS FOR SNARE DRUM

5507P—13" Snare Drum	\$7.00
5508P—14" Snare Drum	7.50
5509P—15" Snare Drum	8.00
5510P—16" Snare Drum	8.50

SNARE HEADS

5567P—13" Snare Drum	\$6.00
5568P—14" Snare Drum	6.50
5569P—15" Snare Drum	7.00
5570P—16" Snare Drum	7.50

TOM TOM HEADS

5600P—12" Tom Tom	\$6.50
5601P—13" Tom Tom	7.00
5602P—14" Tom Tom	7.50
5603P—16" Tom Tom	8.50
5604P—18" Tom Tom	9.75

BASS DRUM HEADS

5522P—18" Bass Drum	\$16.00
5524P—20" Bass Drum	17.00
5526P—22" Bass Drum	18.00
5528P—24" Bass Drum	19.00
5530P—26" Bass Drum	21.00
5532P—28" Bass Drum	22.00
5534P—30" Bass Drum	23.00
5536P—32" Bass Drum	25.00

GRETSCH BAND BELLS

GLOCKENSPIEL

An impressive addition to any concert orchestra or marching band, Gretsch bells are designed for playing convenience... styled for flashing prominence on stage or on the marching field... perfectly tuned for unmatched clarity and sweetness. The bars, tuned by latest scientific methods, are of a special aluminum alloy notable for brilliant acoustical qualities and lightweight strength.

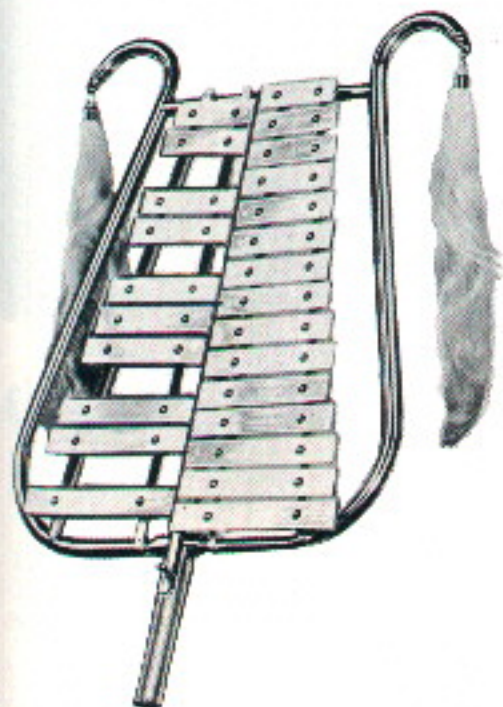

GRETSCH BAND BELLS

With 25 aluminum alloy 1 1/4" x 3/8" bars (2 full chromatic octaves) with special volume adjustment, mounted on new improved tubular frame. Height of lyra, 28"; maximum width, 21"; weight, 11 1/2 lbs. Complete with white horse hair plumes, carrying belt, zipper-closing bag and mallet.
5656 - With Chrome plated lyra and natural polished bars... **\$150.00**

GRETSCH "PATHFINDER" BAND BELLS

Light weight model with 25 aluminum alloy 1" x 3/4" bars (2 full chromatic octaves) mounted on new, improved tubular frame. Height, 24 1/2"; width, 17"; weight only 7 1/2 lbs.! Ideal for the junior corps. Equipment includes: 2 white horse hair plumes, carrying belt, zipper-closing carrying bag and one mallet.
5660 - With Chrome plated lyra; natural polished bars... **\$116.00**

BAND BELL ACCESSORIES

- 5672** - Band Bell Horse Hair Plumes Pr. **\$3.30**
- 5673** - Band Bell Carry Strap with leather holster for shaft... **7.50**
- 5674** - Band Bell Cover, zipper-closing; heavy durable fabric **13.50**
- 5276** - Bell Mallets, 1" ivory plastic ball **1.25 B**

GRETSCH PEDAL TYMPANI

Made of solid seamless copper hand-buffed to a brilliant luster, these 28" and 25" deep parabolic kettles are richly resonant, finer in tone. Touch the sensitive pedal—get immediate action throughout the entire range. Tone changes are fast, easy, accurate. No awkward clutch or ratchets are needed, so there's nothing to stick or squeak. Six suspension struts give solid support. Roller wheels move in any direction, lock tympani in position. All metal parts are Chrome plated. Comes with sticks and fibre head protectors. A truly unique model—the most popular tympani in musical history.

4472 - Gretsch Pedal Tuned Tympani, sizes 28" and 25", complete with Fibre Head Protectors, Roller Coasters and one Pair Tympani Sticks **\$625.00 B**

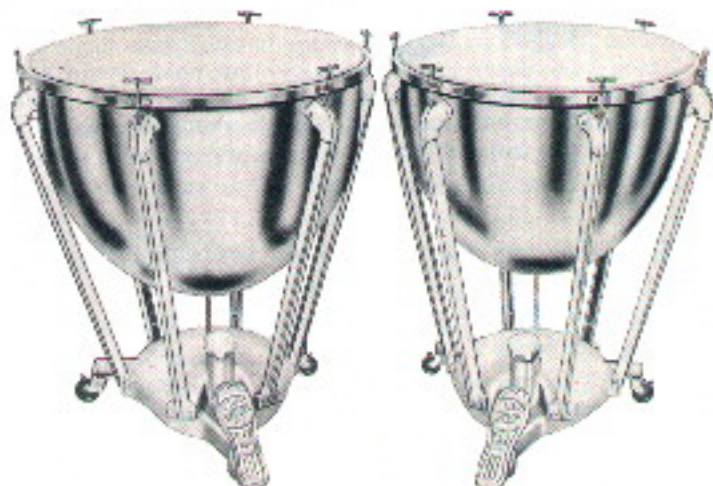

GRETSCH MARCHING DRUMS

"THAT GREAT GRETSCH SOUND" MARCHES AHEAD

Whatever the weather, your Gretsch drums look and sound great all the time... ever-brilliant in tone performance... always colorful and bright in Gretsch-Sparkle, gleaming Gretsch-Pearl or lustrous Lacquer, with all metal parts in non-tarnishing Chrome.

Gretsch "On the March" drums feature their exclusive 6-ply molded shell construction which guarantees perfect round for the life of the drum. Inside, shells are finished with a special moisture-resistant, metallic Lacquer. Die-cast streamlined tension casings are self-seating, self-aligning, and strip-proof.

For variety in your tonal effects, Gretsch also features the new "Micro-Sensitive" throw-off snare strainer that's quick and effective.

Band directors and drummers all look to Gretsch for beauty and lasting, unflinching service. They depend on Gretsch for superb tonal quality... the unmistakable excellence of "That Great Gretsch Sound."

GRETSCH TUNABLE TIMBALES

Two popular models, both featuring the Gretsch heavy spun brass, reinforced shells—stronger, more rigid than the rolled type. Sturdy, Chrome plated stand adjusts to playing height, for sitting or standing; folds compactly. Wide, heavy metal flesh hoops, fine for rim shots. Streamlined tension casings with self-aligning, strip-proof rods.

PX4480—"Latin" model with 13" x 6" and 11" x 6" spun brass shells in Chrome plate which nest compactly for easy packing; with sticks and stand. Set **\$99.50**

PX4481—"Mambo King" model with 14" x 6" and 13" x 6" polished spun brass shells. Complete with sticks, stand, and cowbell holder (not illustrated). Set **\$102.50**

GRETSCH TIMBALE STICKS

5225—Turned from rock Maple in correct size and weight. Length, 14"; with rounded ends Pr. **.40**

TIMBALE STAND

4487—Timbale stand, adjustable, chrome without brackets **\$10.50**



GRETSCH DRUMMERS' CASTANETS AND TRIANGLES



GRETSCH DRUMMERS' CASTANETS

Modeled from hard, resonant bakelite ebony. Produce a crisp, characteristic castanet tone.

4870—Bakelite Castanets in sets of 4, each pair joined by cord Set **\$2.20**

4871—Drummers' Castanet; one pair tied with gut on ebonized hard wood handle **\$2.75**

4872—Drummers' Castanet; two pairs tied with gut on ebonized hard wood handle **\$4.10**

DRUMMERS' TRIANGLES

Highly tempered, heavy tool steel, Nickel plated. Clear, resonant tone. Each with striker.

4880—Triangle, 6" with striker **\$2.00**

4881—Triangle, 8", with striker **2.50**

4882—Triangle, 10", with striker **3.25**

GRETSCH TAMBOURINES



FOR QUALITY AND TONE

SPLIT-RIM TAMBOURINES

Natural Maple rims; Nickel plated steel jingles.

4851—7" rim, 6 sets jingles **3.50**

SOLID RIM TAMBOURINES

Dark Walnut finish rims. Professional Nickel silver jingles, superior in tone.

4858—10" rim, 9 sets jingles. **6.00**

4859—10" rim, 17 sets (2 rows). **7.50**



GRETSCH "TOURNAMENT" MARCHING DRUMS

SEPARATE TENSION WITH FULLY FLANGED METAL HOOPS

Fiery brilliance of color...sleek, modern design...plus the kind of tone that commands attention...these are the exciting qualities that put Gretsch on the march in the finest Drum Corps and Marching Bands. All of these features built in:

- Exclusive 6-ply molded shells (lifetime perfect round guaranteed)
- Streamlined die-cast tension casings
- Snap-in key holder • key snaps in place (Patent Pending)
- Self-seating, self-aligning, strip-proof tension rods
- Fully flanged molded counter hoops
- Inner tone controls for batter head on snares and tenors
- Metal parts Chrome plated at no extra cost
- Perma-Tone heads
- "Micro-Sensitive" snare strainer

"TOURNAMENT" PARADE SNARE DRUM

All are equipped with "Responso" 16 strand all metal snares. Each complete with drum sticks and sling.

Mahogany or Lacquer & Chrome

PX4580—Shell, 14" x 10"	\$77.00
PX4582—Shell, 15" x 12"	90.00
PX4584—Shell, 16" x 12"	98.00

Gretsch-Pearl & Chrome (available in Tri-Tone Pearl finish)

PX4581—Shell, 14" x 10"	\$89.00
PX4583—Shell, 15" x 12"	102.00
PX4585—Shell, 16" x 12"	110.00

For Standard Throw-off Snare Strainer instead of "Micro-Sensitive" deduct \$8.00.

For Gut Snares, add \$2.00

"TOURNAMENT" MODEL TENOR DRUMS

Tenor drums have flanged non-rusting metal hoops for additional flash. Each with sling and one pair of beaters.

Mahogany or Lacquer & Chrome

PX4561—Shell, 14" x 10"	\$77.00
PX4563—Shell, 15" x 12"	90.00
PX4565—Shell, 16" x 12"	98.00

Gretsch-Pearl & Chrome (available in Tri-Tone Pearl Finish)

PX4562—Shell, 14" x 10"	\$89.00
PX4564—Shell, 15" x 12"	102.00
PX4566—Shell, 16" x 12"	110.00

SEPARATE TENSION SCOTCH BASS DRUMS

Ideal for drum corps and marching bands because they adapt perfectly for single stick drumming as well as the spectacular, double stick Scotch-style overhand technique. The narrower shells mean less weight, while the tone is full and solid, adequate to all demands. Also available in smaller sizes on special order. Each with sling and one pair Scotch beaters.

Mahogany or Lacquer & Chrome

PX4619—Shell, 26" x 10"	\$112.00
PX4623—Shell, 28" x 10"	120.00

Gretsch-Pearl & Chrome (available in Tri-Tone Pearl Finish)

PX4620—Shell, 26" x 10"	\$132.00
PX4624—Shell, 28" x 10"	140.00

The price of Gretsch-Pearl includes Pearl Inlaid Hoops Without Extra Charge.

For Pearl Inlaid Hoops on Lacquer Finish Drums add \$5.00



GRETSCH "PARADE KING" MARCHING DRUMS

SEPARATE TENSION WITH WOOD COUNTER HOOPS

For those corps which prefer the conventional wood counter hoops because of their lighter weight and greater tensioning scope, here is the "Parade King" series... in exclusive Gretsch colors and finishes, built to these exacting Gretsch specifications:

- Exclusive 6-ply molded shells (lifetime perfect round guaranteed)
- Streamlined die-cast tension casings
- Snap-in key holder • key snaps in place (Patent Pending)
- Self-seating, self-aligning, strip-proof tension rods
- Inner tone controls for batter head on snares and tenors
- Metal parts Chrome plated at no extra cost
- Perma-Tone heads
- "Micro-Sensitive" snare strainer

"PARADE KING" SNARE DRUMS

All are equipped with "Responso" 16 strand all metal snares. Each complete with drum sticks and sling.

Mahogany or Lacquer & Chrome	
PX4586—Shell, 14" x 10"	\$74.00
PX4588—Shell, 15" x 12"	87.00
PX4590—Shell, 16" x 12"	95.00
Gretsch-Pearl & Chrome (available in Tri-Tone Pearl finish)	
PX4587—Shell, 14" x 10"	\$86.00
PX4589—Shell, 15" x 12"	99.00
PX4591—Shell, 16" x 12"	107.00

For Standard Throw-off Snare Strainer instead of "Micro-Sensitive" deduct \$8.00.

For Gut Snares, add \$2.00

"PARADE KING" TENOR DRUMS

Available in three popular sizes, each with a pair of felt head beaters and sling.

Mahogany or Lacquer & Chrome	
PX4550—Shell, 14" x 10"	\$74.00
PX4552—Shell, 15" x 12"	87.00
PX4554—Shell, 16" x 12"	95.00
Gretsch-Pearl & Chrome (available in Tri-Tone Pearl Finish)	
PX4551—Shell, 14" x 10"	\$86.00
PX4553—Shell, 15" x 12"	99.00
PX4555—Shell, 16" x 12"	107.00

The price of Gretsch-Pearl includes Pearl Inlaid counter hoops without extra charge. For Pearl Inlaid hoops with Lacquer finished drums add \$2.50

SEPARATE TENSION SCOTCH BASS DRUMS

Full, solid tone plus narrow, lightweight shell is the ideal combination of features for drum corps and marching bands. Each with sling and one pair Scotch beaters. Also available in smaller sizes on special order.

Mahogany or Lacquer & Chrome	
PX4619—Shell, 26" x 10"	\$112.00
PX4623—Shell, 28" x 10"	120.00
Gretsch-Pearl & Chrome (available in Tri-Tone Pearl Finish)	
PX4620—Shell, 26" x 10"	\$132.00
PX4624—Shell, 28" x 10"	140.00

The price of Gretsch-Pearl finish includes Pearl Inlaid Hoops without extra charge. For Pearl Inlaid Hoops on Lacquer Finish Drums add \$5.00.



GRETSCH "GUARDSMAN" MARCHING DRUMS

SEPARATE TENSION WITH
STREAMLINED ROD CASINGS

These superior tone drums look expensive, are priced low. In exclusive Gretsch colors and finishes, built to famous Gretsch specifications.

- Exclusive 6-ply molded shells and hoops for lifetime perfect round
- Streamlined die-cast tension rod casings
- Snap-in key holder • key snaps in place (Patent Pending)
- Strip-proof tension rods
- Metal parts in gleaming, non-tarnishing Chrome
- Perma-Tone heads
- Separate tension
- Standard Throw-off strainer

GRETSCH "GUARDSMAN" MARCHING SNARE DRUM

All are equipped with "Responso" 16 strand all metal snares. Each complete with drum sticks and sling.

Mahogany or Lacquer & Chrome

PX4592—Shell, 14" x 10"	\$64.00
PX4594—Shell, 15" x 12"	75.00
PX4596—Shell, 16" x 12"	78.00

Gretsch-Pearl & Chrome (available in Tri-Tone Pearl Finish)

PX4593—Shell, 14" x 10"	\$76.00
PX4595—Shell, 15" x 12"	87.00
PX4597—Shell, 16" x 12"	90.00

For Gut Snares, add \$2.00

FOR FULLY FLANGED METAL COUNTER HOOPS ON MARCHING
SNARE AND TENOR DRUMS ADD \$5.00.

GRETSCH "GUARDSMAN" TENOR DRUM

Each with sling and one pair of felt head beaters.

Mahogany or Lacquer & Chrome

PX4567—Shell, 14" x 10"	\$64.00
PX4569—Shell, 15" x 12"	75.00
PX4571—Shell, 16" x 12"	78.00

Gretsch-Pearl & Chrome (available in Tri-Tone Pearl Finish)

PX4568—Shell, 14" x 10"	\$76.00
PX4570—Shell, 15" x 12"	87.00
PX4572—Shell, 16" x 12"	90.00

The price of Gretsch-Pearl includes Pearl Inlaid counter hoops without extra charge. For Pearl Inlaid hoops with Lacquer finished drums add \$2.50.

GRETSCH "GUARDSMAN" SCOTCH BASS DRUM

Every top quality construction detail you want and need for good looks and superior tone. Each with one pair felt head beaters and sling. Also available in smaller sizes on special order.

Mahogany or Lacquer & Chrome

PX4629—Shell, 26" x 10"	\$106.00
PX4631—Shell, 28" x 10"	116.00

Gretsch-Pearl & Chrome (available in Tri-Tone Pearl Finish)

PX4630—Shell, 26" x 10"	\$126.00
PX4632—Shell, 28" x 10"	136.00

The price of Gretsch-Pearl finish includes Pearl Inlaid Hoops without extra charge. For Pearl Inlaid Hoops on Lacquer Finish Drums add \$5.00.



GRETSCH "RENOWN" MARCHING DRUMS

These marching drums made to Gretsch quality specifications include:

- Exclusive 6-ply Molded Shells and Hoops for Lifetime Perfect Round
- Mahogany Shell with Natural Maple Hoops in Regular Finish
- Double Claw Hooks • Perma-Tone Heads
- Colored Lacquer Finish in Solid Color or Tri-Tone at Small Additional Cost
- Standard Throw-off strainer
- Snap-in key holder • key snaps in place (Patent Pending)

RENOWN SINGLE TENSION MARCHING DRUMS

With Standard throw-off snare strainer for varied tonal effects and all-metal "Responso" snares. Mahogany shell with natural Maple hoops. Sling & hickory sticks included. Not made in Gretsch-Pearl finishes.

PX4531—Shell, 15" x 12" \$55.00

PX4532—Shell, 16" x 12" 59.00

Colored Lacquer, including Tri-Tone, \$2.00 extra. Pearl Inlaid Hoops \$2.50 extra.

RENOWN SINGLE TENSION TENOR DRUMS

Regular finish is Mahogany shell with natural Maple hoops. Colored Lacquer finish, including Tri-Tone (your choice of colors) \$2.00 extra. Each with sling and one pair felt beaters. Not made in Gretsch-Pearl.

PX4573—Shell, 14" x 10" \$50.00

PX4574—Shell, 15" x 12" 55.00

For Pearl Inlaid Hoops add \$2.50

RENOWN SINGLE TENSION SCOTCH BASS DRUMS

Regular finish is Mahogany shell with natural Maple hoops. Colored Lacquer finish, solid color or Tri-Tone. \$2.50 extra. Not made in Gretsch-Pearl finish. Each with sling and one pair felt head Scotch beaters.

PX4643—Renown Scotch Bass Drum, Shell 26" x 8" \$85.00

PX4645—Renown Scotch Bass Drum, Shell 28" x 8" 96.00

PX4647—Renown Scotch Bass Drum, Shell 28" x 10" ... 99.00

SINGLE TENSION—CHROME PLATED METAL PARTS

GRETSCH "RENOWN" JUNIOR MARCHING SNARE DRUM



Absolute top value in its field!

Junior drummers love a parade when they're marching with this splendid, single tension snare drum. Built to full Gretsch-"Renown" specifications, including the exclusive 6-ply molded shell that guarantees lifetime perfect round...all metal parts in non-tarnishing Chrome..."Responso" 12 strand all metal snares with throw-off strainer...Double claw hooks. Regular finish is Mahogany shell with natural Maple hoops. Price includes heavy duty sling, pair drum sticks. (\$2.00 extra for colored Lacquer finish)

PX4542—Renown Junior Snare Drum, Shell 14" x 10" With 8 Rods \$45.00

PX4543—Renown Junior Snare Drum, Shell 14" x 10" With 6 Rods 42.00

GRETSCH

DRUM BOOKS



9329
All American Drummer, Phil Grant.

1.00



9335
Haskell Harr Drum Method, Book I.

1.50B



9336
Haskell Harr Drum Method, Book II

1.50B



9318
Syncopated Rolls for the Modern Drummer, Vol. I, Jim Blackley.

2.75B



9319
Syncopated Rolls for the Modern Drummer, Vol. II, Jim Blackley.

2.50B

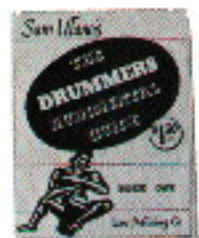

9333
Rudimental Guide, Book I, Sam Ulano

1.50

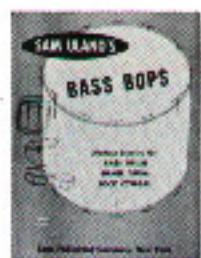

9334
Bass Bops, Sam Ulano

1.50



9338
Rudi Bops, Sam Ulano

1.50

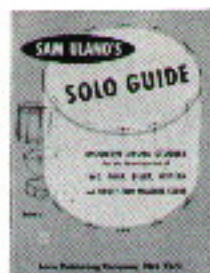

9340
Solo Guide, Book I, Sam Ulano...

1.50



9342
A B C Guide to Drumming, Sam Ulano...

1.50



9343
Introduction to the Drum Set, Book I, Charlie Perry..

1.50B



9344
Introduction to the Drum Set, Book II, Charlie Perry..

2.50B



9332
Latin American Rhythm Instruments, Morales & Adler

3.00B



9341
Design for the Drum Set, Don Lamond

2.50B

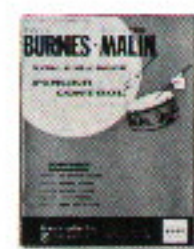

9310
Finger Control, Burnes & Malin

2.00B



9311
Drum Breaks & Fill-Ins, Igoe & Adler

1.50B



9312
Modern Mallet Method, Phil Kraus

3.00B



9316
Variations of Drumming, Ralph C. Pace.

3.00B

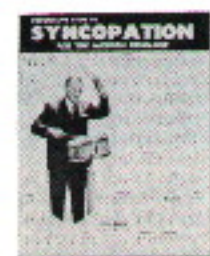

9314
Syncopation for Modern Drummer, Ted Reed.....

2.00B



9315
Drum Soles & Fill-Ins, Ted Reed.....

2.00B

THE PERFECT WAY TO DRUMMING TECHNIQUE with your **GRETSCH** **DRUM KITS**

Everything the student drummer requires for all types of drumming in one easy to carry, attractive case. The smart, separate tension pearl snare drum with Chrome plated stand is the correct instrument for concert band and orchestra and also can be used to build a complete dance outfit. The heavy duty foam rubber practice pad fits right on the drum head and gives the student the same response as the drum itself. Included is a detailed instruction book for students.



PX4080—Gretsch Pearl-Chrome Student Drum Ensemble **\$78.00**

THE GRETSCH PEARL-CHROME STUDENT DRUM ENSEMBLE CONSISTS OF:

- 1 each X4105 Dixieland White Pearl-Chrome Snare Drum (14" x 5½") **\$56.00**
- 1 each 4983 Drum Stand Chrome **10.50**
- 1 each 9329 All American Drummer (Instruction Book) **1.00**
- 1 pair 5220 Drum Sticks **1.20**
- 1 each 5819 "Silent-Sound" Cushion ... **2.50**
- 1 each 5104 Fibre Case with Tray for Accessories **9.75**

Total Value at Regular Prices \$80.95

Deluxe "Renown" Drummer Kit contains all the items as the above but is supplied with a "Renown" Pearl-Chrome Snare Drum, Wire Brushes and an attractive Hard Shell Case.

PX4084—Gretsch Deluxe "Renown" Pearl-Chrome Drum Ensemble **\$110.00**

THE GRETSCH DELUXE "RENOWN" PEARL-CHROME DRUM ENSEMBLE CONSISTS OF:

- 1 each X4103 "Renown" Pearl-Chrome Snare Drum (14" x 5½") **\$68.00**
- 1 each 4983 Heavy duty Snare Drum Stand, Chrome **10.50**
- 1 each 9329 All American Drummer (Instruction Book) **1.00**
- 1 pair 5220 Drum Sticks **1.20**
- 1 pair 5236 Wire Brushes **1.85**
- 1 each 5819 "Silent-Sound" Cushion **2.50**
- 1 each 5107 Deluxe Drum Case **29.50**

Total Value at Regular Prices \$114.55



THE GREAT GRETSCH COLORS

GLEAMING GRETSCH PEARLS AND LACQUER FINISHES on the BANDSTAND
or on PARADE the choice of America's top drummers.

BLUE SPARKLE



GOLD SPARKLE

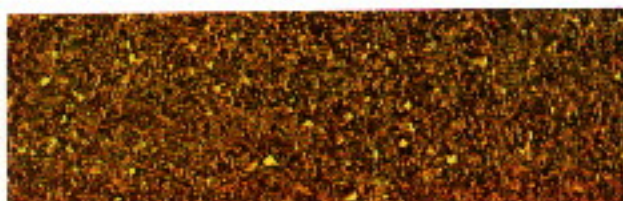

SILVER SPARKLE



BURGUNDY SPARKLE

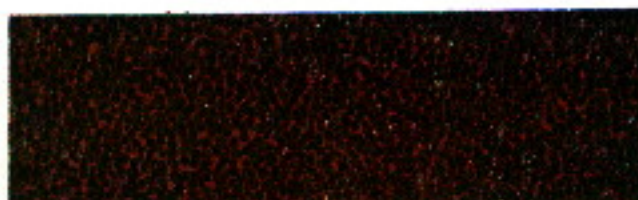

RED SPARKLE

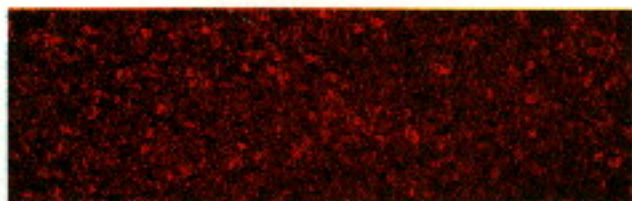

WHITE PEARL



CHAMPAGNE SPARKLE



MIDNIGHT BLUE PEARL



GREEN SPARKLE

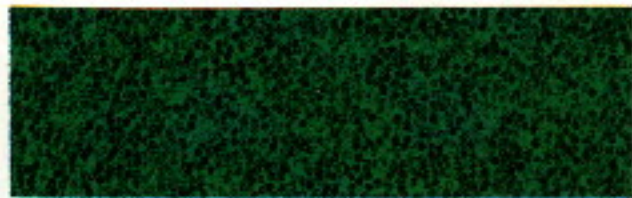

BLACK PEARL



TANGERINE SPARKLE



JET BLACK NITRON



Index

INDEX	Pages	INDEX	Pages
AJAH A Cymbals	14	Heads, Drum	28-29
Bass Drums, Concert	11	Hi-Hats and Pedals	16-17
Bass Drums, Dance	12	Hooks, Drum	21
Bass Drums, Parade	36-40	Hoops, Drum	21
Bass Drums, Scotch	36-40	Instruction Books	32
Bass Drum Floor Holder	19	K. ZILDJIAN Cymbals	14-15
Bass Drum Heads	28-29	Keys, Drum	20
Bass Drum Sticks	26	Keys, Rail Consolette	20
Bells, Band	30	Kits, Drum	33-34
Bell Mallets	26	Leg Rests	23
Bongos	22	Mallets	26
Bongo Heads	29	Maracas	22
Books, Instruction	32	Parade Drums	36-40
Brushes	27	PERMA-TONE Heads	28
Calfskin Heads	29	Pedals, Drum	17
Cases, Drum and Tom Tom	23	Practice Pads	27
Castanets	31	Practice Pad Stand	27
Claves	22	Rail Consolettes	13
Cocktail Drums	12	Scotch Bass Drums	36-40
Counter Hoops	21	Slings, Drum	23
Covers	23	Snare Drum Heads	28-29
Cowbells and Holders	18	Snare Drum Hoops	21
Cymbals	14-15	Snare Drums, Orchestra and Band	8-10
Cymbal Accessories	15-16	Snare Drums, Marching	36-40
Drums, Bass, Concert	11	Snares	19
Drums, Bass, Dance	12	Snare Drum Sticks	24-25
Drums, Bass, Marching	36-40	Snare Strainers	20
Drums, Bass, Scotch	36-40	Sound Effects Accessories	30
Drums, Cocktail	12	Spurs, Bass Drum	18
Drums, Parade	36-40	Stands, Cymbal	16
Drums, Snare, Marching	36-40	Stands, Drum	18-19
Drums, Snare, Orchestra and Band	8-10	Sticks, Timbale	22
Drums, Tenor	36-40	Sticks, Snare Drum	24-25
Drum Covers and Cases	23	Sticks, Tympani	26
Drum Hardware	20-21	Sticks, Bass Drum	26
Drum Heads	28-29	Sticks, Scotch Bass and Tenor Drum	26
Drum Hooks	21	Tambourines	31
Drum Hoops	21	Tenor Drums	36-40
Drum Kits	33-34	Thrones	18
Drum Outfits	2-7	Timbales	22
Drum Parts	18-19	Timbale Sticks	22
Drum Repair Parts	20-21	Tom Toms and Accessories	13
Drum Rod Assemblies	21	Tom Tom Heads	28-29
Drum Rod Casings (Lugs)	21	Tom Tom Hoops	21
Drum Slings	23	Triangles	31
Drum Stands	18-19	Tympani Heads	29
Drum Sticks	24-26	Tympani Sticks	26
Drummers' Thrones	18	WIDE-42 Power Snares	19
Flesh Hoops	21	Woodblock and Holder	18
Glockenspiel and Accessories	30	Xylophone Mallets	26
Glockenspiel Mallets	28		
Gourd (Guira)	22		



THAT GREAT
GRETSCH
SOUND

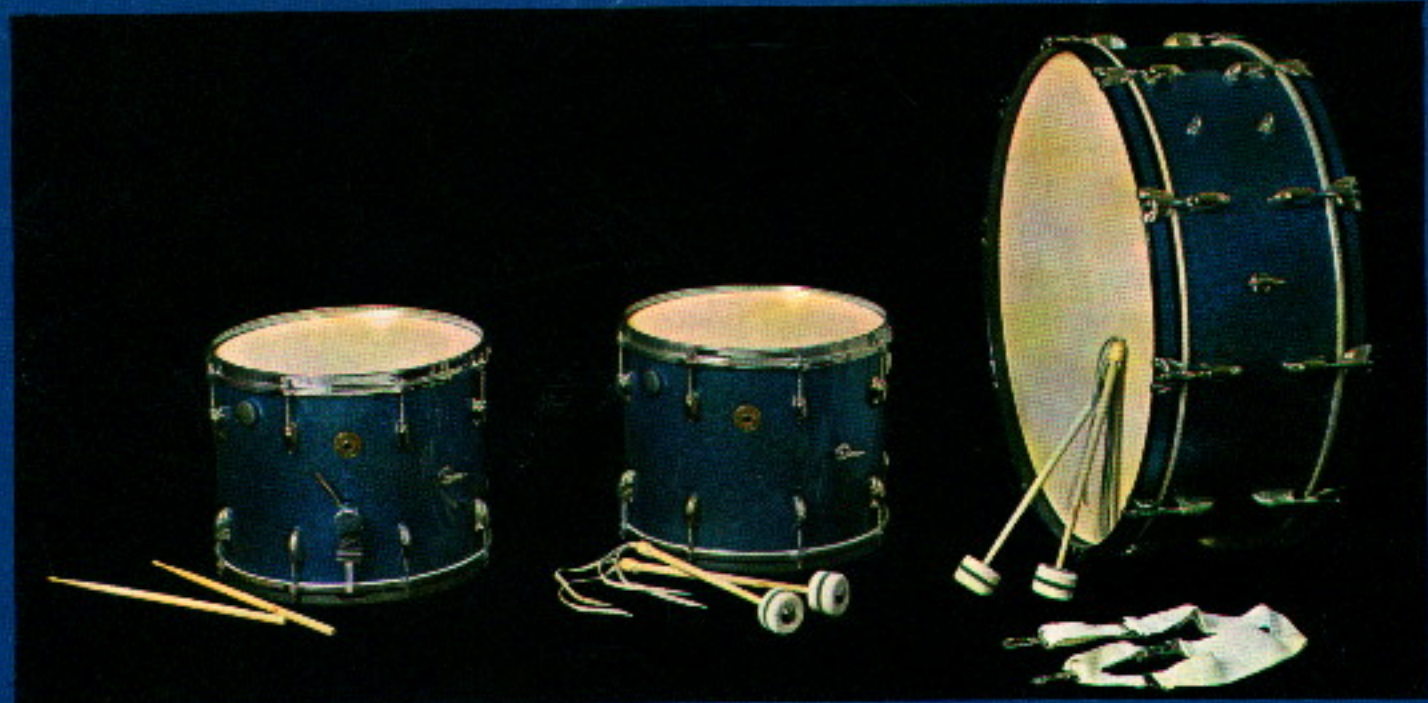

THE FRED. GRETSCH MFG. CO.

60 Broadway, Brooklyn 11, New York, N. Y.
218 South Wabash Avenue, Chicago 4, Illinois

Printed in U.S.A.