



The Rhythm-Masters and Vibra-Cussionists of the Famous Waring's Pennsylvanians Orchestra, Stuart Churchill and Percy McClintock (Center), Shown With Director Fred Waring In The Chicago Theatre, Chicago, Where The Band Played During The Week Of August 3rd to 9th, 1934. The Equipment Is Exclusively Leedy.

Leedy

CATALOG "U"

"THE
WORLD'S FINEST
DRUMMERS'
INSTRUMENTS"

LEEDY "DRUM TOPICS"

The Exclusive Drummers' Newspaper of News and Information

Leedy "Drum Topics" is well known by the drummers' fraternity both here and abroad as the exclusive drummers' newspaper published for, by, and in the interests of drummers. Every issue is overflowing with valuable information on drumming that is gathered from here, there and everywhere, pictures and news items of drummers in every part of this, and every foreign country, inside information on how to produce the newest necessary effects, new stunts, news of the profession, the latest information on the newest instruments and accessories, hints, tips, jokes and stories. It is exclusively a drummers' newspaper from beginning to end, and is published as frequently as material and developments warrant getting new issues out.

If you have never received this valuable little magazine, or if you have moved and not notified us of the change of address, be sure to send us your name and address so we can put you on our mailing list to receive it in the future. The latest issue will be sent you at once and future issues will be mailed as they are published. Keep us posted on changes in address, and "Drum Topics" will follow you no matter how much you move around. There is no charge or obligation of any kind for this publication—it is sent postpaid, and we are glad to send it to anyone interested in it.

Send in the name of your drummer friends who are not receiving "Drum Topics"—they will find it as interesting and helpful as the thousands of drummers who have been reading it for years. Address requests to

"DESK 34"

Leedy Mfg. Co., Inc.

LEEDY BUILDING

ELKHART, INDIANA



Drummer Anthony Briglia and Director Glen Gray Of The Renowned Casa Loma Orchestra Which Has Achieved Nation-Wide Prominence and Favor Through Its Splendid Radio Programs. Briglia's Leedy Drums Have Supplied Casa Loma's Rhythm For The Past Five Years.



Drummer Frank Frisselle, With Rudy Vallee's Renowned Orchestra, and the Versatile Director-Entertainer Rudy Vallee Himself In A Picture Posed Specially For This Catalog. In Addition To His Leedy Drums, Frisselle Also Uses Leedy Tympani and Vibraphone.

THE LEEDY "ROLL-OFF" No. 3

The Outdoor Drummers' Bluebook of Information and Equipment

The new Leedy "Roll-Off" No. 3 is even bigger and better than the previous editions which were acknowledged to be the finest and most valuable texts of their kind ever published, because of the wealth of practical information contained between their covers.

This new edition—the Leedy "Roll-Off" No. 3—contains even more information than the preceding editions. The technique of fancy Tenor and Scotch Bass Drumming, for instance, is fully illustrated and described, new drum corps formations and instrumentations which include the Tenor Bugle are shown and the whys and wherefores of the Piston G-D Bugle are explained. There are pointers on how to organize, finance and conduct a drum corps as well as suggestions for the individual corps members when on parade, on the contest field, etc. Pictures of many of the finest Leedy equipped drum corps are included also.

The most complete line of the newest and finest band and drum corps Drums and Accessories is fully described and illustrated. Bugles, Bugle Bells, Bell Lyrae, Batons, Cymbals, Sticks, Slings and a full line of accessories, new "Full Dress" finishes for drums, new and improved instruments and accessories—in fact everything but uniforms—are shown on its 72 pages.

Those interested in band and drum corps work are invited to write for this new, free edition of the "Roll-Off"—your copy will be mailed postpaid and without obligation by addressing your postcard or letter to

DEPT. "U"

Leedy Mfg. Co., Inc.

LEEDY BUILDING

ELKHART, INDIANA

"THE WORLD'S FINEST DRUMMERS' INSTRUMENTS"

This is more than a mere slogan—it is a title attached to Leedy products by satisfied customers themselves, and not by any member of the Company. Drummers have for many years been in the habit of describing this or that Leedy item as "the world's finest", and we at the factory heard this voluntary remark so often from every state and every country that, in 1923, it was decided to use it in connection with our name on all printed matter. We do not believe it is an exaggeration to state that this title is deserved. For nearly forty years (1895-1934) the Leedy Mfg. Co. has been producing the highest grade of Drummers' equipment it is possible to construct. And for nearly forty years it has been the Leedy principle to serve the Drummer with a professional understanding and personal attention to the smallest detail. These facts, coupled with the belief that we must first benefit the Drummer before we can benefit ourselves, long ago awarded us the leading place in the percussion instrument manufacturing field. We are, naturally, proud of this leadership, and therefore pledge ourselves to continue the policies which have made it possible.

Back of the superb quality of every Leedy instrument is a large staff of skilled workmen that has helped to create and produce it. In this group

of craftsmen each one is a master at his own particular task. His individual skill is based upon long years of experience with Drums and Drummers, greatly amplified by the wonderful facilities that have been developed in the Leedy plant during nearly forty years of progress. These are the reasons for another phrase often heard among Drummers—"Leedy certainly puts out **WONDERFUL WORKMANSHIP**". Care is our watchword at all times. We know that the reputation of our customers is as deeply involved as our own, therefore we have never tried to cut corners by cutting quality. Fine instruments cannot be slapped together. Neither can quality be maintained by the "assembled" plan. Bear in mind that when you choose Leedy you are choosing instruments manufactured and assembled under the supervision of Drummers. Many of us here at the plant have made our living as professionals—we have lived in your own world and still count ourselves a part of it. The men whose pictures you see on this page have for many years worked in close cooperation with a much larger group of factory officials and workmen. This combination of experienced drum specialists has won for Leedy instruments the foremost place in the field of rhythm.



THE FACTORY THAT PRODUCES
"THE WORLD'S FINEST DRUMMERS' INSTRUMENTS"



Geo. H. Way



Jack Roep



C. C. Barker



P. C. Laycock



Edw. C. Cortes

THAT WE MAY SERVE YOU MOST SATISFACTORILY

ABOUT YOUR LOCAL LEEDY DEALER

The Drummer has ALL to gain and NOTHING to lose by purchasing from the Dealer. Not many years ago every Drummer had to send direct to the factory for his needs. This method of buying involved considerable effort. It meant writing letters, buying Money Orders, paying transportation charges, and, worst of all, loss of time. Now, most towns and all cities have reliable Leedy Dealers who are ever ready to serve the Drummer as he wants to be served. Some of the benefits of buying through the Dealer are—

- First . . . The ability to purchase on time payments.
- Second . . The saving of transportation charges.
- Third . . . The saving of valuable time—quick service.
- Fourth . . . A stock of items to choose from.
- Fifth . . . Keeping posted on the latest ideas.
- Sixth . . . The privilege of testing and trying an article before buying.
- Seventh . . The Dealer's guarantee in addition to Leedy's.
- Eighth . . . The duty to purchase in your O.H.T. (Own Home Town).

We will be pleased to supply you with the name of your nearest Leedy Dealer if you do not know who he is.

ABOUT THIS CATALOG "U"

This is Leedy's 21st Catalog—the most complete ever published. It is the only catalog that lists and illustrates every practical instrument and accessory for Drummers' use. Note that it is very easy to locate items, even without referring to the index, inasmuch as the illustrations are all at the extreme outside margins of the pages. Please be sure to specify catalog "U" and give the correct catalog number when ordering or writing about any article within these pages. By following this simple rule you will save delay, confusion and unnecessary correspondence. It will enable us to give you quicker and better service.

ABOUT THE LEEDY GUARANTEE

You incur no risk when you choose Leedy merchandise. Every instrument or accessory in this catalog is guaranteed to be exactly as represented. And every item is sold with the understanding that if for any reason it does not prove entirely satisfactory it may be returned within five days, provided the transportation charges are prepaid, and the purchase price will be cheerfully refunded.

We Cannot Guarantee Drum Heads, Imported Cymbals, Chinese Wood Blocks or Chinese Tom Toms.

GENERAL INFORMATION

Write Your Order legibly, being sure to give the correct catalog numbers and names, sizes and finishes together with other information that will be helpful in filling your order correctly, and state how you want it shipped.

Postage Stamps will be accepted in payment of orders amounting to not more than \$1.00. Orders amounting to more than \$5.00 will be shipped by Express subject to three (3) days trial if desired, provided an amount sufficient to cover the cost of transportation is included with the order—this amount will be deducted from the invoice by us. Goods shipped C.O.D. Parcel Post are not subject to trial.

Post Office Money Orders are the safest and most satisfactory means of remittance. We advise their use when possible.

Address All Mail and make all remittances payable to the

LEEDY MANUFACTURING CO. Inc.,
Elkhart, Indiana

Cable Address—"Leedy"; Codes—A B C 6th Western Union.

Telegram Orders must be sent prepaid and will be filled at the sender's risk. Please confirm these orders by letter.

Be Sure your name and address are plainly marked on the packages when you send merchandise to the factory.

All Prices are F.O.B. Elkhart, Indiana, and are subject to change without notice. The prices quoted in this catalog cancel and supersede those in all previous editions.

One Week to Ten Days is required for "Full Dress" finishes.

THE FAMOUS "BROADWAY" FLOATING HEAD SNARE DRUMS

Broadway Snare Drums as now presented with the New Automatic Tension Snare Devices are indeed the crowning achievements of our nearly forty years of drum designing and manufacturing. They are more than our statement, "The World's Finest Drummers' Instruments", implies . . . they are the means by which any Drummer can improve his playing ability—and of course improved playing ability means traveling on a direct road to greater earnings. They are Drums built to a new high mark of efficiency and beauty—Drums that far outshine yesterday's models—"Thoroughbreds" which out-perform all others.

NEW PLAYING EASE

That is what the new "BROADWAY" stands ready to deliver. With the first few taps of the sticks you will "feel" a new "throwback"—a new delicacy—that "something" you have long had in mind but never before experienced. Now it's here—a new sensation in Drumming. The "BROADWAY" snaps like the spark of a wireless at the slightest touch of the operator's finger on the key. And there is a reserve power always at your command without the forced strain of slamming. It never "chokes" under either the lightest or heaviest beats.

NEW TONAL BRILLIANCE

The chief reason for both the new tonal brilliance and playing ease in "BROADWAY" Drums equipped with the New Automatic Tension Snare Devices is because each snare is attached to an individual spring which automatically assures that every snare is straining at exactly the same tension. In other

words, the snares are self-aligning. Without further explanation we believe the Drummer can easily understand the great value of this new invention. The snares do not have to be adjusted—they adjust themselves automatically. Now, when you use a Leedy "BROADWAY" with this device your leader and other musicians will be quick to recognize a new life—a new quality in drum tones never before realized. It means a new brilliance in rhythm. Rhythm without brilliance is as colorless and monotonous as the rhythm of the jungle. Here we have a drum in which even those untrained in music can hear that clear, penetrating snap combined with depth, richness and carrying power that fit so well, whether the music be standard or "modern".

CONSTRUCTION

These new BROADWAYS are obtainable in three set-ups of snares. The name "Dual" is still retained as in former catalogs for the type with the snares under both heads. The name "Parallel" is also still retained for the type with the snares under the bottom head only.

Both of these drums are equipped with the automatic tension snare devices. The drum with the "Standard" snare strainer is the same as the former Standard model. Compare the BROADWAY series of drums with any other on the market. Balance one against the other for performance—tone—mechanical design—construction—workmanship and appearance and you will know why the world's leading professionals use and endorse Leedy BROADWAY Drums. You can buy a cheaper drum but you can not buy a better one. A BROADWAY will help put you over.

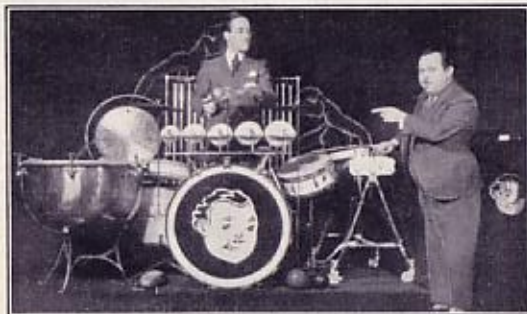

Ted E. Tillmann, versatile drummer with Henry Busse's nationally renowned radio and dance orchestra uses and endorses Leedy equipment exclusively (4-16-34). Yes! That's Busse at the right.

Leedy Broadway Drums Are Used and Indorsed by More of the World's Outstandingly Fine Drummers Than Any Other Snare Drum Made

THE ALL METAL "BROADWAY" FLOATING HEAD SNARE DRUM



A short study of the several exclusive features as found only on Leedy "Broadway" Drums will soon convince the most skeptical that they are truly the ultimate in design and fine workmanship. Every instrument is built to meet the professional Drummer's most exacting requirements for tone, ease of playing, and service. The fact that the majority of the best Drummers with "name" bands and orchestras play and endorse these models is your assurance that a Leedy "Broadway" is superior.

The New Automatic Tension snare device as now applied to both the Parallel and Dual model "Broadway" Drums is the only means by which each and every snare can be brought to, and held at, exactly the same tension. This is accomplished by the use of a small coiled spring on one end of each snare, alternately arranged at both ends in two metal housings. Every snare automatically adjusts itself to the same tension as the snares next to it. There is no individual adjustment necessary.

The outstanding superior features that make both the all-metal and wood shell "Broadways" the Peer of all Drums are, (1) Floating Heads—(2) Automatic Tension Snares—(3) Parallel Snare Strainer—(4) Self-Aligning Rods—(5) Spun Brass Seamless One-Piece Shell—(6) Internal Tone Control. We hope you will investigate these points and compare them from a practical and efficiency standpoint with all other drums. Read about the above mentioned features on pages 8 and 9.

WITH THE DUAL, PARALLEL OR STANDARD SNARE STRAINERS

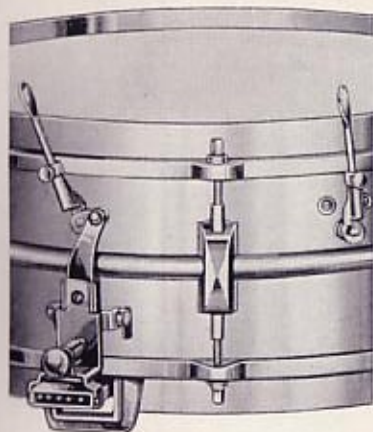

With
Snares
Under
Both
Heads



Snares
Under
Bottom
Head
Only



Snares
Under
Bottom
Head
Only

THE "BROADWAY" DUAL NICKEL PLATED

No. 2000 ... 5" x 14"	} \$52.50
No. 2002 ... 6½" x 14"	
No. 2004 ... 6½" x 15"	

CHROMIUM PLATED

No. 2006 ... 5" x 14"	} \$67.50
No. 2008 ... 6½" x 14"	
No. 2010 ... 6½" x 15"	

THE "BROADWAY" PARALLEL NICKEL PLATED

No. 2030 ... 5" x 14"	} \$45.00
No. 2032 ... 6½" x 14"	
No. 2034 ... 6½" x 15"	

CHROMIUM PLATED

No. 2036 ... 5" x 14"	} \$60.00
No. 2038 ... 6½" x 14"	
No. 2040 ... 6½" x 15"	

THE "BROADWAY" STANDARD NICKEL PLATED

No. 2060 ... 5" x 14"	} \$35.00
No. 2062 ... 6½" x 14"	
No. 2064 ... 6½" x 15"	

CHROMIUM PLATED

No. 2066 ... 5" x 14"	} \$45.00
No. 2068 ... 6½" x 14"	
No. 2070 ... 6½" x 15"	

All Drums Equipped With Slik Wire Wound Snares Unless Ordered Otherwise. Gut or James Snares Supplied at No Extra Cost.
Black or White Duco on Shells on Special Order Supplied at No Extra Cost.

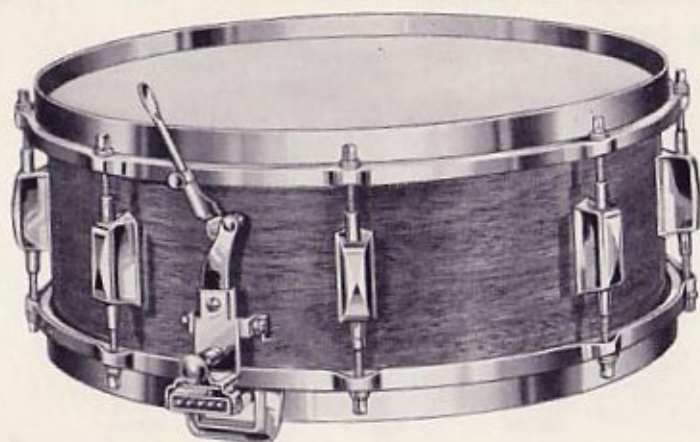
SOLID MAHOGANY SHELL "BROADWAY" FLOATING HEAD SNARE DRUM

Drummers who prefer a wood shell instrument will find the Leedy "Broadway" Solid Mahogany model to be the acme of perfection in this type drum. The wood is of the African variety, thoroughly seasoned and finished with the rich natural grain showing through a hand-rubbed glossy surface. Excepting for the shell, this drum is identical to the all metal models shown on pages 4 and 5. It has all the same qualifications, such as sensitiveness—snappy tone—playing ease—and beauty.

All "Broadway" Drums are now made with three different snare assemblies—Dual, Parallel and Standard. See pages 5 and 7, and note mechanical details on pages 8 and 9. You will find these points interesting. The Dual and Parallel are now equipped with the wonderful Automatic Tension Snare Device, a feature that plays a big part in making these the finest drums in the world. The working parts of the Dual and Parallel strainers have been completely redesigned: they are more efficient than ever.

The importance of the Floating Head and Self-Aligning Rod features as employed on all "Broadway" models cannot be over-estimated. They are not just mere "talking points"—they are exclusive Leedy inventions built on technical and scientific principles that actually make a better drum. And of course a better drum means better playing and greater personal satisfaction. Read about the Floating Head and Self-Aligning Rod features which are illustrated and described on page 8.

Leedy

DRUMMERS' INSTRUMENTS

WITH CHOICE OF THE DUAL, PARALLEL OR STANDARD SNARE STRAINERS



With
Snares
Under
Both
Heads



Snares
Under
Bottom
Head
Only



Snares
Under
Bottom
Head
Only

THE "BROADWAY" DUAL NICKEL PLATED

No. 2012	5" x 14"	} \$52.50
No. 2014	6 1/2" x 14"	
No. 2016	6 1/2" x 15"	

CHROMIUM PLATED

No. 2018	5" x 14"	} \$65.00
No. 2020	6 1/2" x 14"	
No. 2022	6 1/2" x 15"	

THE "BROADWAY" PARALLEL NICKEL PLATED

No. 2042	5" x 14"	} \$45.00
No. 2044	6 1/2" x 14"	
No. 2046	6 1/2" x 15"	

CHROMIUM PLATED

No. 2048	5" x 14"	} \$57.50
No. 2050	6 1/2" x 14"	
No. 2052	6 1/2" x 15"	

THE "BROADWAY" STANDARD NICKEL PLATED

No. 2072	5" x 14"	} \$35.00
No. 2074	6 1/2" x 14"	
No. 2076	6 1/2" x 15"	

CHROMIUM PLATED

No. 2078	5" x 14"	} \$42.50
No. 2080	6 1/2" x 14"	
No. 2082	6 1/2" x 15"	

All Drums Equipped With Silk Wire Wound Snares Unless Ordered Otherwise. Gut or James Snares Supplied at No Extra Cost.

Black or White Duco, or the New Blue Tri-Tone Finish, on Shells Supplied on Special Order at No Extra Cost.

SIX REASONS FOR THE SUPERIORITY OF



SNARES AGAINST HEAD

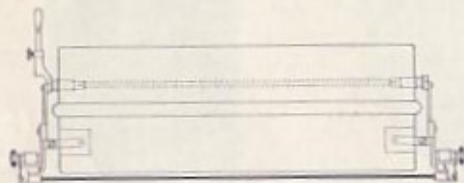

SNARES AWAY FROM HEAD

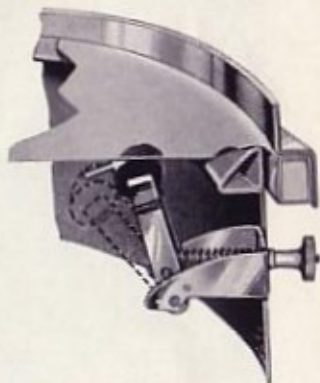
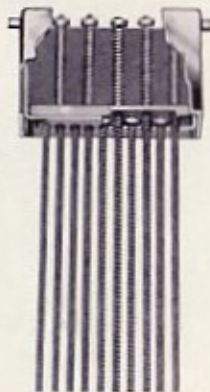
**IMPROVED PARALLEL STRAINER**

The well-known Leedy Parallel Snare Strainer has been redesigned to embody several very efficient improvements. It is now built of heavier parts and is therefore much stronger. The snares throw on and off at both ends, always remaining taut and at an even tension. There is no complicated mechanism—only a few moving parts. These are precision-built and work with ease and positive action. It has no superior.

AUTOMATIC TENSION SNARES

This wonderful Leedy invention is now a part of the Parallel snare strainers on both Parallel and Dual model "Broadway" Drums. One end of each snare "floats" within a short coiled wire spring arranged alternately in two metal housings, one at each end. This spaces the snares so they cannot touch each other at any point and keeps them always at exactly the same tension. They align themselves on the springs.

INTERNAL TONE CONTROL

The built-in Internal Tone Control on all "Broadway" model drums permits the Drummer to apply any desired pressure against the *inner side* of the batter head to modify the drum tone and to eliminate the natural drum "ring" found in all snare drums. The felt control pad is operated from the side of the drum by a milled thumb-nut. Awkward external controls are now unnecessary.

Also Sold Separately. See Page 80

Leedy

DRUMMERS' INSTRUMENTS

BROADWAY FLOATING HEAD SNARE DRUMS



WITH THE FLOATING HEAD



Floating Head Slopes Away From Edge of Shell Eliminating all Head and Flesh Hoop Binding. This Assures Even Head Tension

Flesh Hoop Fits Counter Hoop and Remains Away from Shell at all Points

WITHOUT THE FLOATING HEAD



Head Turns Sharp Angle in Passing Over Edge of Shell on Other Style Drums. This Jams the Head and Prevents Even Head Tension

Flesh Hoop Hugs Shell and Causes Binding

INTERNAL SNARES—DUAL MODEL

Broadway DUAL Model Drums are equipped with an extra set of INTERNAL wire snares under the batter head. When used in conjunction with the outside Parallel snares they more than double the volume and carrying power in PPP playing. When used alone they permit extreme delicacy and snap in PFP playing. They operate in the same manner as the Parallel snares by means of an independent, easy-moving lever.

SELF-ALIGNING RODS

All Broadway Floating Head Drums are equipped with SELF-ALIGNING rods—an exclusive Leedy feature found on no other drum made. The receiving tubes (lugs) swing within the center supports (casings) on modified universal joints which are free to move in every direction. This assures a perfect alignment of threads which eliminates binding and stripping, and also permits a more uniform head tension.

FLOATING HEADS

Floating Heads mean that the flesh hoops do not and cannot touch the shell at any point of the circle. They fit snugly in the flanges of the counter hoops instead of hugging the shell as on other models. This eliminates all possibility of binding flesh hoops and reduces head breakage. Best of all, however, it guarantees even head tension, which in turn guarantees an easier playing, and better sounding, instrument.

"FULL DRESS" DRUMS PROCLAIM THE MODERN SPIRIT

The Drummer of today is frequently the featured musician of his organization because his work permits him to combine his playing with whatever showmanship he possesses. The term musician is used with emphasis because he plays not only drums but, in many cases, Xylophone, Vibraphone, Chimes and perhaps Tympani as well. His outfit is flashy and colorful because he realizes that if he wants to increase his worth to his organization, and his earnings as well, he must appeal to his audiences through their eyes as well as through their ears. He has learned through experience that a snappy appearing outfit builds prestige for him and helps to put his playing across just as fine stage settings help to make a vaudeville act or a show a greater success than it would be without them.

Today's Drummer knows that to attain success he must keep pace with the changing trends in the music world both in his playing and in his instruments—and the trend in instruments has long been those that combine BEAUTY with COLOR and FLASH. The Leedy "Full Dress" finishes shown in this catalog do all of that—and more!

Leedy "Full Dress" finishes are not a luxury, but a sound business investment that actually pays dividends in several ways. Instruments finished in Pearl or Sparkling Pyralin are stronger, more durable and retain their original beauty and lustre longer than other models because these materials will not scratch, mar or dent as easily as painted surfaces. Also, their highly reflective, lustrous, smooth, hard surfaces are the easiest of all finishes to keep clean and are guaranteed for the life of the instruments on which they are used. The new Oriental Pearl "Full Dress" finish, described and illustrated in full color on page 13 of this catalog is the newest, and one of the most beautiful, Pearl finishes that it has been our pleasure to offer on Leedy instruments. We suggest that you write for a free sample piece of this lovely Pearl so you can judge its full beauty. A sample piece will be sent without obligation upon request.

Do not overlook the advantages of Chromium and Nobby

Gold plating, which are more fully described on page 79, when you purchase new instruments. Either of these platings will add materially to the appearance of your outfit, and Chromium plating will add to its life as well.

The tonal excellence and mechanical perfection of Leedy drums and mallet played instruments are in no way impaired by adding Leedy "Full Dress" finishes. They are the finest, the most beautiful, and the most durable instruments made, and are "The World's Finest Drummers' Instruments" in the fullest, and strictest, sense of the word.

SPARKLING TWO-TONE DIAMONDS

These Diamonds give added distinction to "Full Dress" drums. Supplied in any combination possible with Sparkling Gold, Green, Red or Silver at the prices listed, or on your present drums at these prices plus the cost of shipping your instruments to and from our factory.

Be Sure to State Color Combination Wanted

Orchestra Snare Drums...\$4.50 Bass Drums\$10.00



Sparkling Red Border
With Sparkling Silver Center



Sparkling Silver Border
With Sparkling Green Center



Sparkling Gold Border
With Sparkling Red Center

SPARKLING GOLD MODELS

Here are Drums of gleaming gold—Drums that stand out like a rising sun—truly powerful magnets attracting all eyes to the "Rhythm Master". The beautiful material used in the making of these wonder instruments has a smooth, glass-like surface that throws off startling, flashing highlights, while within it are countless thousands of sparkling, diamond-like particles of a rich golden hue. The Sparkling Gold material is practical as well as beautiful because it is harder than the hardest wood, therefore more durable. It will not mar or crack and is far easier to clean than any painted finish. The surface is as smooth as that of a mirror. They are Drums that any Drummer will be mighty proud to own. Send for a sample of this new Sparkling Gold with the larger and more brilliant flakes—it will be mailed to you free of charge and without obligation.

THE BROADWAY SNARE DRUM—5" x 14"

Also Made in 6½" x 14" and 6½" x 15" at the Same Prices

	STANDARD Snare Strainer		PARALLEL Snare Strainer		DUAL Snare Strainers	
Nobby Gold	No. 2200	\$50.00	No. 2210	\$65.00	No. 2220	\$72.50
Chromium	No. 2202	50.00	No. 2212	65.00	No. 2222	72.50
Nickel	No. 2204	42.50	No. 2214	52.50	No. 2224	60.00

Choice of Gut, Silk Wire Wound or James Wire Snare

Sparkling Two-Tone Diamond Decorations (see page 10) \$4.50 Extra

THE BASS DRUM—14" x 28"

Other Size Bass Drums Made to Order at Proportionate Prices

	STANDARD Solid Shell		SPARTAN 3-Ply Shell	
Nobby Gold	Separate Tension Rods	No. 4230 \$92.50	No. 4250	\$82.50
Nobby Gold	Single Tension Rods	No. 4232 80.00	No. 4252	70.00
Chromium	Separate Tension Rods	No. 4234 92.50	No. 4254	82.50
Chromium	Single Tension Rods	No. 4236 80.00	No. 4256	70.00
Nickel	Separate Tension Rods	No. 4238 80.00	No. 4258	70.00
Nickel	Single Tension Rods	No. 4240 70.00	No. 4260	60.00

Sparkling Two-Tone Diamond Decorations (see page 10) \$10.00 Extra

Bass Drum Scenes and Interior Lights on Page 23



MARINE PEARL MODELS

Marine Pearl—a supreme creation—the original “Full Dress” Drum finish—introduced by Leedy in 1925. It is still the most popular seller because of the regal beauty of the gleaming white surface which gives forth hundreds of shafts of strong light beams in all directions. Also because, with Nickel, Chromium or Nobby Gold Rods, it is appropriate in any orchestral setting. A sample of the Marine Pearl material (or any of the other “Full Dress” finishes) will be sent on request without obligation. Try giving it a few sharp blows with the butt end of a drum stick or bell mallet—notice that it will not dent or scratch. It is also guaranteed not to warp, crack, chip or peel. Only a soft, damp cloth is needed to remove the most stubborn dirt and to preserve its appearance of newness. Drums finished in this beautiful pearl will far outlast a wood or metal shell instrument.

THE BROADWAY SNARE DRUM—5" x 14"

Also Made In 6½" x 14" and 6½" x 15" at the Same Prices

	STANDARD Snare Strainer	PARALLEL Snare Strainer	DUAL Snare Strainers
Nobby Gold	No. 2100.....\$50.00	No. 2110.....\$65.00	No. 2120.....\$72.50
Chromium	No. 2102..... 50.00	No. 2112..... 65.00	No. 2122..... 72.50
Nickel	No. 2104..... 42.50	No. 2114..... 52.50	No. 2124..... 60.00

Choice of Gut, Silk Wire Wound or James Wire Snares

Sparkling Two-Tone Diamond Decorations (see page 10) \$4.50 Extra

THE BASS DRUM—14" x 28"

Other Size Bass Drums Made to Order at Proportionate Prices

	STANDARD Solid Shell	SPARTAN 3-Ply Shell
Nobby Gold Separate Tension Rods	No. 4130.....\$92.50	No. 4150.....\$82.50
Nobby Gold Single Tension Rods	No. 4132..... 80.00	No. 4152..... 70.00
Chromium Separate Tension Rods	No. 4134..... 92.50	No. 4154..... 82.50
Chromium Single Tension Rods	No. 4136..... 80.00	No. 4156..... 70.00
Nickel Separate Tension Rods	No. 4138..... 80.00	No. 4158..... 70.00
Nickel Single Tension Rods	No. 4140..... 70.00	No. 4160..... 60.00

Sparkling Two-Tone Diamond Decorations (see page 10) \$10.00 Extra

Bass Drum Scenes and Interior Lights on Page 23

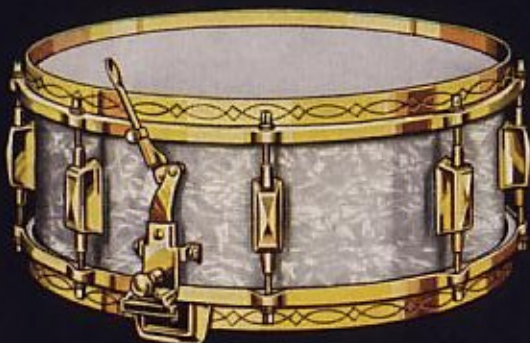

ORIENTAL PEARL MODELS

Here is a sensational new "Full Dress" Pearl finish that will undoubtedly rival the popularity of the present reigning favorites—the regal Marine Pearl and the fascinating Black Pearl. The new Oriental Pearl combines the richness of silver and black with the warmth of iridescent blue, green, purple, red, and gold skillfully fused into the silver, with the pleasing dignity for which the Marine and Black Pearls are famous. Words cannot begin to describe it, and the finest printing falls short of doing justice to its beauty in illustration. Here, for once, man has excelled nature in reproducing the iridescent multi-colored abalone (mother-of-pearl) pearl which the Oriental Pearl simulates. You will never grow tired of it on an outfit with either the Chromium or Nobby Gold drum parts. It's outstanding. A free sample will be sent on request without obligation.

THE BROADWAY SNARE DRUM—5" x 14"

Also Made In 6½" x 14" and 6½" x 15" at the Same Prices

STANDARD Snare Strainer		PARALLEL Snare Strainer		DUAL Snare Strainers	
Nobby Gold	No. 2160 \$50.00	No. 2170 \$65.00	No. 2180 \$72.50
Chromium	No. 2162 50.00	No. 2172 65.00	No. 2182 72.50
Nickel	No. 2164 42.50	No. 2174 52.50	No. 2184 60.00

Choice of Gut, Silk Wire Wound or James Wire Snares

Sparkling Two-Tone Diamond Decorations (see page 10) \$4.50 Extra

THE BASS DRUM—14" x 28"

Other Size Bass Drums Made to Order at Proportionate Prices

STANDARD Solid Shell		SPARTAN 3-Ply Shell	
Nobby Gold	Separate Tension Rods No. 4205 \$92.50	No. 4215 \$82.50
Nobby Gold	Single Tension Rods No. 4206 80.00	No. 4216 70.00
Chromium	Separate Tension Rods No. 4207 92.50	No. 4217 82.50
Chromium	Single Tension Rods No. 4208 80.00	No. 4218 70.00
Nickel	Separate Tension Rods No. 4209 80.00	No. 4219 70.00
Nickel	Single Tension Rods No. 4210 70.00	No. 4220 60.00

Sparkling Two-Tone Diamond Decorations (see page 10) \$10.00 Extra

Bass Drum Scenes and Interior Lights on Page 23

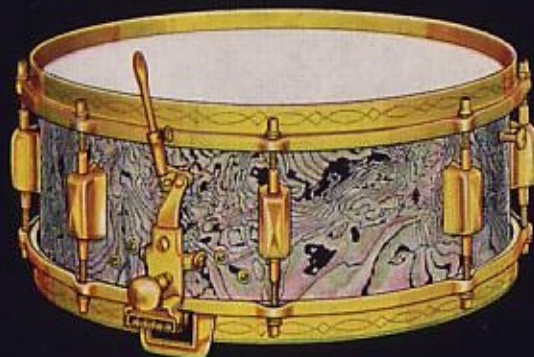

BLACK ELITE MODELS

Black Elite "Full Dress" Models have been one of Leedy's most popular presentations for several years. The Black Nickel on the snare drum shell is not of a bluish gun metal cast, but a true, deep, glossy black that has the appearance of new patent leather. This, of course, forms a striking contrast with the engraving on the shell (which shows thru in Gold) and the shiny Nobby Gold rods, hoops and snare strainer. The Bass Drum is finished in Black Luster Duco—the kind that looks the best and wears the longest. You can't go wrong in choosing Black to predominate your outfit; it is always captivating and in good taste. It is correct in any setting for any job, and a finish that you will never tire of. These instruments are easily kept clean by wiping occasionally with a damp soft cloth.

THE BROADWAY SNARE DRUM—5" x 14"

Also Made in 6½" x 14" and 6½" x 15" at the Same Prices

	STANDARD Snare Strainer	PARALLEL Snare Strainer	DUAL Snare Strainers
Nobby Gold	No. 2700 \$45.00	No. 2710 \$60.00	No. 2720 \$67.50
Chromium	No. 2702 45.00	No. 2712 60.00	No. 2722 67.50
Nickel	No. 2704 37.50	No. 2714 47.50	No. 2724 55.00

Choice of Gut, Silk Wire Wound or James Wire Snares

Sparkling Two-Tone Diamond Decorations Supplied Only on Wood Shell Models in Black Duco Finish (see page 10) \$4.50 Extra

THE BASS DRUM—14" x 28"

Other Size Bass Drums Made to Order at Proportionate Prices

	STANDARD Solid Shell	SPARTAN 3-Ply Shell
Nobby Gold .. Separate Tension Rods	No. 4730 \$67.50	No. 4750 \$57.50
Nobby Gold .. Single Tension Rods	No. 4732 55.00	No. 4752 45.00
Chromium .. Separate Tension Rods	No. 4734 67.50	No. 4754 57.50
Chromium .. Single Tension Rods	No. 4736 55.00	No. 4756 45.00
Nickel .. Separate Tension Rods	No. 4738 55.00	No. 4758 45.00
Nickel .. Single Tension Rods	No. 4740 45.00	No. 4760 35.00

Sparkling Two-Tone Diamond Decorations (see page 10) \$10.00 Extra

Bass Drum Scenes and Interior Lights on Page 23.

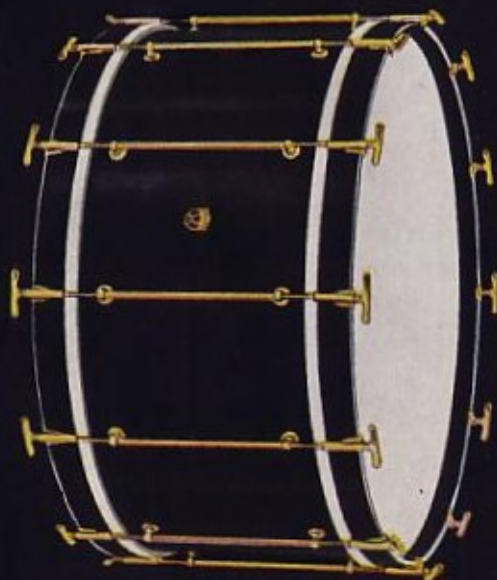

SPARKLING GREEN MODELS

And now we present a startling flash—one with a “punch” that implants a dazzling impression on sight, but which is not in the least gaudy. It is a sparkling effect of the same design and reflecting powers as our Sparkling Gold and Sparkling Silver finishes. The fundamental color is a deep, rich, natural green, from within which thousands of lighter green particles shoot their strong rays in every direction. With Chromium, Nobby Gold or Nickel rods these Drums will “fit” any picture in a most pleasing manner. We fully realize and accept the responsibility that all Leedy “Full Dress” Drums must play and sound as well as they look—they are guaranteed to do so. Send for a sample of this beautiful new Sparkling Green finish today—it will be mailed to you free of charge and without obligation so you can judge the beauty, color and flash of this new material.

THE BROADWAY SNARE DRUM—5" x 14"

Also Made in 6½" x 14" and 6½" x 15" at the Same Prices

	STANDARD Snare Strainer		PARALLEL Snare Strainer		DUAL Snare Strainers	
Nobby Gold	No. 2250	\$50.00	No. 2260	\$65.00	No. 2270	\$72.50
Chromium	No. 2252	50.00	No. 2262	65.00	No. 2272	72.50
Nickel	No. 2254	42.50	No. 2264	52.50	No. 2274	60.00

Choice of Gut, Silk Wire Wound or James Wire Snares

Sparkling Two-Tone Diamond Decorations (see page 10) \$4.50 Extra

THE BASS DRUM—14" x 28"

Other Size Bass Drums Made to Order at Proportionate Prices

	STANDARD Solid Shell		SPARTAN 3-Ply Shell	
Nobby Gold... Separate Tension Rods	No. 4270	\$92.50	No. 4290	\$82.50
Nobby Gold... Single Tension Rods	No. 4272	80.00	No. 4292	70.00
Chromium .. Separate Tension Rods	No. 4274	92.50	No. 4294	82.50
Chromium .. Single Tension Rods	No. 4276	80.00	No. 4296	70.00
Nickel Separate Tension Rods	No. 4278	80.00	No. 4298	70.00
Nickel Single Tension Rods	No. 4280	70.00	No. 4300	60.00

Sparkling Two-Tone Diamond Decorations (see page 10) \$10.00 Extra

Bass Drum Scenes and Interior Lights on page 23

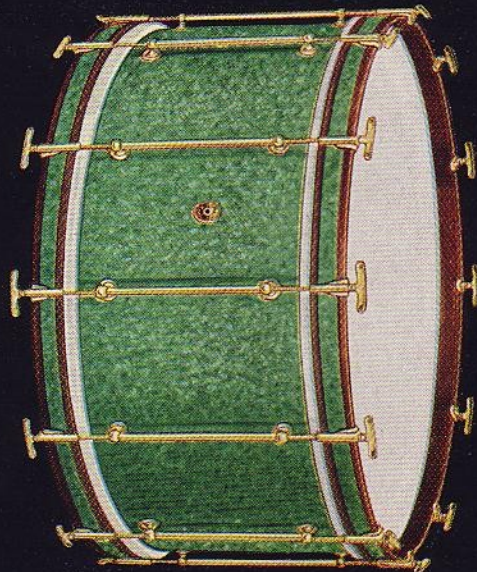
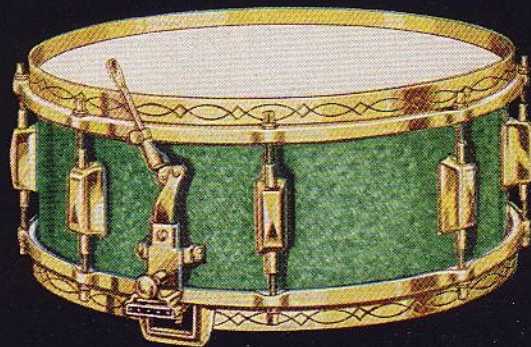

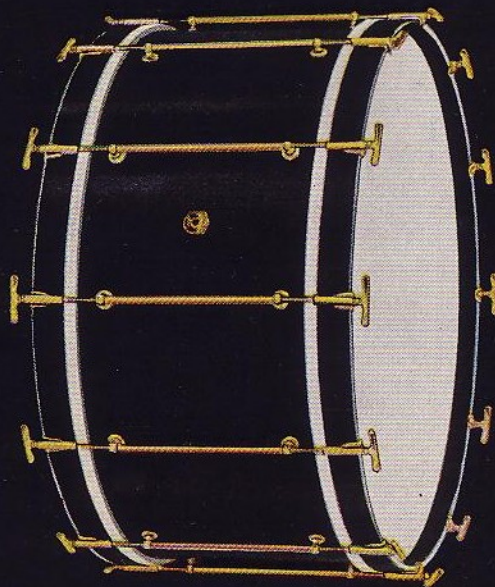
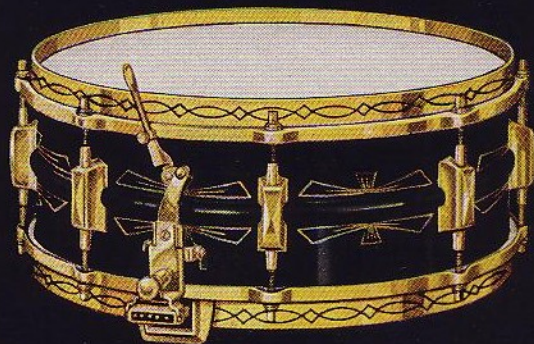

BLACK ELITE MODELS

Black Elite "Full Dress" Models have been one of Leedy's most popular presentations for several years. The Black Nickel on the snare drum shell is not of a bluish gun metal cast, but a true, deep, glossy black that has the appearance of new patent leather. This, of course, forms a striking contrast with the engraving on the shell (which shows thru in Gold) and the shiny Nobby Gold rods, hoops and snare strainer. The Bass Drum is finished in Black Luster Duco—the kind that looks the best and wears the longest. You can't go wrong in choosing Black to predominate your outfit; it is always captivating and in good taste. It is correct in any setting for any job, and a finish that you will never tire of. These instruments are easily kept clean by wiping occasionally with a damp soft cloth.

THE BROADWAY SNARE DRUM—5" x 14"

Also Made in 6½" x 14" and 6½" x 15" at the Same Prices

	STANDARD Snare Strainer	PARALLEL Snare Strainer	DUAL Snare Strainers
Nobby Gold	No. 2700 \$45.00	No. 2710 \$60.00	No. 2720 \$67.50
Chromium	No. 2702 45.00	No. 2712 60.00	No. 2722 67.50
Nickel	No. 2704 37.50	No. 2714 47.50	No. 2724 55.00

Choice of Gut, Silk Wire Wound or James Wire Snares

Sparkling Two-Tone Diamond Decorations Supplied Only on Wood Shell Models in Black Duco Finish (see page 10) \$4.50 Extra

THE BASS DRUM—14" x 28"

Other Size Bass Drums Made to Order at Proportionate Prices

	STANDARD Solid Shell	SPARTAN 3-Ply Shell
Nobby Gold... Separate Tension Rods	No. 4730 \$67.50	No. 4750 \$57.50
Nobby Gold... Single Tension Rods	No. 4732 55.00	No. 4752 45.00
Chromium ... Separate Tension Rods	No. 4734 67.50	No. 4754 57.50
Chromium ... Single Tension Rods	No. 4736 55.00	No. 4756 45.00
Nickel Separate Tension Rods	No. 4738 55.00	No. 4758 45.00
Nickel Single Tension Rods	No. 4740 45.00	No. 4760 35.00

Sparkling Two-Tone Diamond Decorations (see page 10) \$10.00 Extra

Bass Drum Scenes and Interior Lights on Page 23.

WHITE ELITE MODELS

White and Gold—radiating strong transient beams of pure white and gold lights—is a “Full Dress” finish of individual and striking character. The White Duco on the shells gives them a lustrous surface capable of great reflecting powers that will make a lasting impression in favor of the Drummer. White and Gold, like Black and Gold, is appropriate in either conventional or modernistic settings. Leedy White Duco shells are easy to keep clean because of their smooth, hard surface: simply wipe off the dust, dirt and grime with a soft, dampened cloth. These drums are especially attractive with Nobby Gold metal parts because of the striking contrast between shell and hoops and rods. They also present a strikingly handsome appearance with either Nickel or Chromium parts.

THE BROADWAY SNARE DRUM—5" x 14"

Also Made In 6½" x 14" and 6½" x 15" at the Same Prices

	STANDARD Snare Strainer		PARALLEL Snare Strainer		DUAL Snare Strainers	
Nobby Gold	No. 2800	\$42.50	No. 2810	\$57.50	No. 2820	\$65.00
Chromium	No. 2802	42.50	No. 2812	57.50	No. 2822	65.00
Nickel	No. 2804	35.00	No. 2814	45.00	No. 2824	52.50

Choice of Gut, Silk Wire Wound, or James Wire Snares

Sparkling Two-Tone Diamond Decorations Supplied Only on Wood Shell Models in White Elite Finish (see page 10) \$4.50 Extra

THE BASS DRUM—14" x 28"

Other Size Bass Drums Made to Order at Proportionate Prices

	STANDARD Solid Shell		SPARTAN 3-Ply Shell		
Nobby Gold... Separate Tension Rods	No. 4830	\$67.50	No. 4850	\$57.50	
Nobby Gold... Single Tension Rods	No. 4832	55.00	No. 4852	45.00	
Chromium ... Separate Tension Rods	No. 4834	67.50	No. 4854	57.50	
Chromium ... Single Tension Rods	No. 4836	55.00	No. 4856	45.00	
Nickel	Separate Tension Rods	No. 4838	55.00	No. 4858	45.00
Nickel	Single Tension Rods	No. 4840	45.00	No. 4860	35.00

Sparkling Two-Tone Diamond Decorations (see page 10) \$10.00 Extra

Bass Drum Scenes and Interior Lights on Page 23.

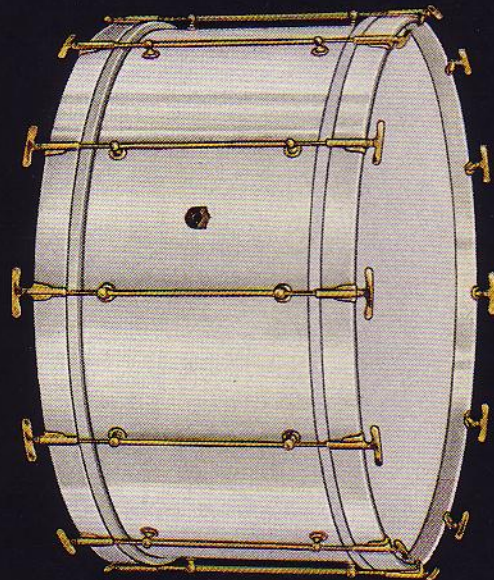
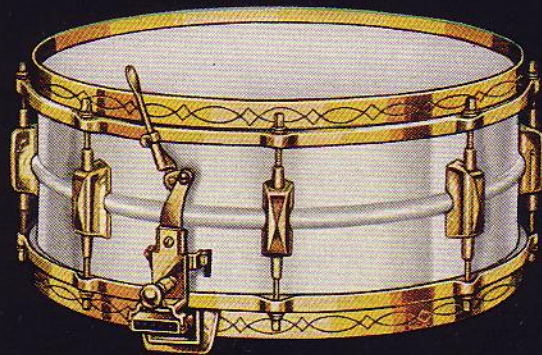

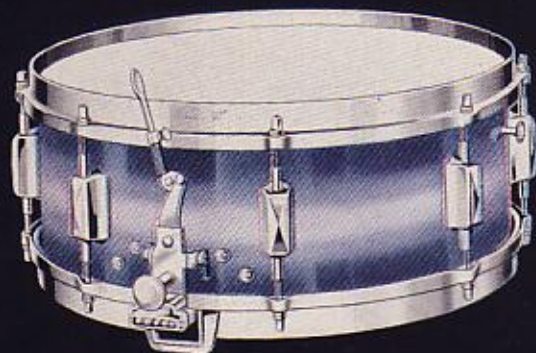

TRI-TONE MODELS

The Leedy Tri-Tone "Full Dress" finish is not only highly attractive, modern and flashy, but inexpensive as well because it costs no more than regular Duco or Mahogany finishes. The unusual effect shown to the left is obtained by using silver and blue lacquer—the blue lacquer in its full strength at the outer edges of the shell which is skillfully fused with the silver as it approaches the middle of the shell to form a pleasing silver-blue tone which shades off to a pure silver at the middle of the shell. After the lacquer has been applied, the shell is painstakingly rubbed and polished to bring out the tri-tone color effect in its full richness and to give the shell a beautifully polished surface. The Sparkling Silver Inlaid Counter Hoops add the finishing touch to the bass drum. Prices below are for the drums as illustrated. You can't go wrong by buying these drums:

THE BROADWAY SNARE DRUM—5" x 14"

Also Made In 6½" x 14" and 6½" x 15" at the Same Prices

	STANDARD Snare Strainer	PARALLEL Snare Strainer	DUAL Snare Strainers
Nobby Gold	No. 2930 \$42.50	No. 2935 \$57.50	No. 2940 \$65.00
Chromium	No. 2931 42.50	No. 2936 57.50	No. 2941 65.00
Nickel	No. 2932 35.00	No. 2937 45.00	No. 2942 52.50

Choice of Gut, Silk Wire Wound, or James Wire Snare

Other than Blue and Silver Combinations \$2.00 Extra
Sparkling Two-Tone Diamond Decorations (see page 10) 4.50 Extra

THE BASS DRUM WITH INLAID COUNTER HOOPS—14" x 28"

Other Size Bass Drums Made to Order at Proportionate Prices

	STANDARD Solid Shell	SPARTAN 3-Ply Shell
Nobby Gold..... Separate Tension Rods	No. 4310 \$70.50	No. 4320 \$60.50
Nobby Gold..... Single Tension Rods	No. 4311 58.00	No. 4321 48.00
Chromium..... Separate Tension Rods	No. 4312 70.50	No. 4322 60.50
Chromium..... Single Tension Rods	No. 4313 58.00	No. 4323 48.00
Nickel..... Separate Tension Rods	No. 4314 58.00	No. 4324 48.00
Nickel..... Single Tension Rods	No. 4315 48.00	No. 4325 38.00

Without Inlaid Counter Hoops on Above Bass Drums 3.00 Less
Other than Blue and Silver Combinations \$2.50 Extra
Sparkling Two-Tone Diamond Decorations (see page 10) 10.00 Extra

Bass Drum Scenes and Interior Lights on Page 23.

THE CENTURY "FULL DRESS" OUTFIT

CENTURY OUTFIT IN BLUE TRI-TONE AND NICKEL

No. 5367 - \$102.50

The CENTURY "Full Dress" Outfit is an excellent new set-up that is practical, complete and flashy, at a price that is well within the reach of most drummers. The drums and accessories are thoroughly professional in quality and is drummer-correct in every detail. While the outfit illustrated is in the new Tri-Tone Blue finish, the drums may be had in any of the other seven "Full Dress" finishes illustrated and described on the preceding pages at the prices shown below. The items included in the outfit are listed in detail below for your careful study. A saving in both money and time is effected by buying a complete outfit instead of assembling one for yourself.

CHOICE OF EIGHT FINISHES

Sparkling Gold	No. 5360	\$130.50
Marine Pearl	No. 5361	130.50
Oriental Pearl	No. 5362	130.50
Black Pearl	No. 5363	130.50
Sparkling Green	No. 5364	130.50
Black Elite	No. 5365	102.00
White Elite	No. 5366	102.50
Blue Tri-Tone	No. 5367	102.50

With Metal Parts in Chromium or Nobby Gold \$23.00 Extra

THE CENTURY OUTFIT SET-UP AS FOLLOWS

5"x14" Broadway Standard Floating Head Snare Drum	Stayon Non-Swing Cymbal Holder
14"x28" Spartan Single Tension Bass Drum	Low Sock Cymbal Pedal
Professional Pedal with Spurs and Cymbal Holder	2 10" Deep Cup Brass Cymbals
10" American Brass Cymbal	10" Chee Foo Chinese Tom Tom
10" Genuine "Stanople" Cymbal (thin)	Stayon Tom Tom Holder
	Bass Drum Tone Control
	Wire Brushes—Wood Handles
	Pair H-14 Hickory Drum Sticks
	Beginner's Drum Method

No Substitutions or Omissions

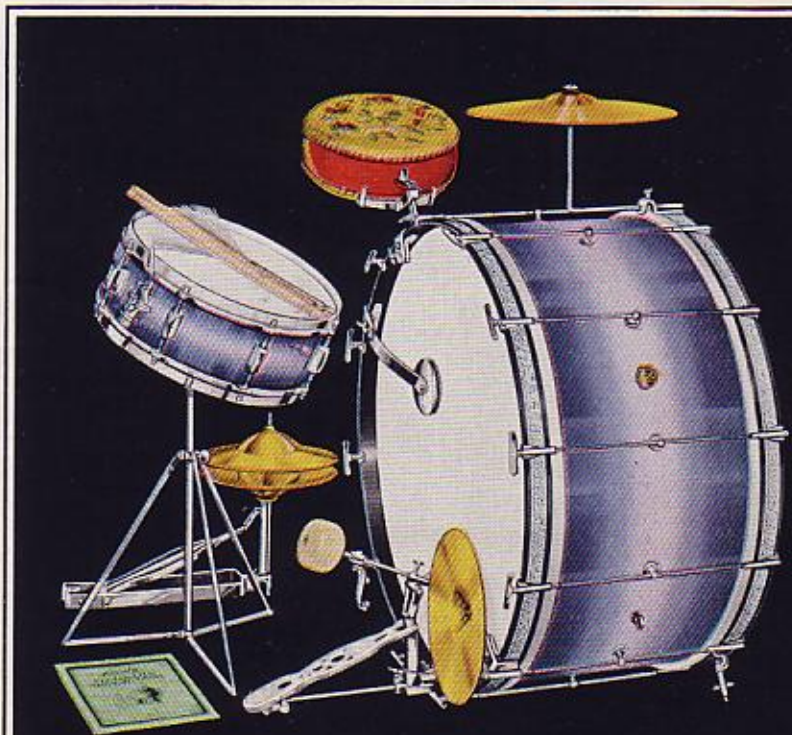

THE NATIONAL "FULL DRESS" OUTFIT

NATIONAL OUTFIT IN BLACK ELITE FINISH

No. 5340 - \$148.00

With Nobby Gold Metal Parts and Two-Tone Diamond Decorations



This new outfit is called "The National" because there has been a constant demand for such an assembly from the majority of states, and other countries as well. It presents an ultra smart appearance with the Two-Toned Diamond Decorations of Sparkling Gold and Red between each rod on the glossy black Duco shells of both drums, and the Sparkling Gold inlaid hoops on the bass drum. Bear in mind that it is also possible to obtain these drums with the shells in any of the various "Full Dress" finishes listed below which are illustrated and described on pages 10 to 18. Every item is "Drummer Correct" in every detail and carries the usual Leedy guarantee. You'll like this wonderful set-up.

CHOICE OF EIGHT FINISHES

With Nobby Gold Metal Parts and Two-Tone Diamond Decorations

Sparkling Gold	No. 5335	\$176.00
Marine Pearl	No. 5336	176.00
Oriental Pearl	No. 5343	176.00
Black Pearl	No. 5338	176.00
Sparkling Green	No. 5339	176.00
Black Elite	No. 5340	148.00
White Elite	No. 5341	148.00
Blue Tri-Tone (Inlaid Hoops)	No. 5344	148.00

Chromium Plated Metal Parts Optional at the Same Prices
For Outfit With Nickel Plated Metal Parts Deduct \$27.50

THE NATIONAL OUTFIT—SET UP AS FOLLOWS

5"x14" Broadway Standard Floating Head Snare Drum	Low Sock Cymbal Pedal
14"x28" Spartan Single Tension Bass Drum	2—10" Deep Cup Brass Cymbals
Professional Pedal with Spurs and Cymbal Holder	10" Chee Foo Chinese Tom Tom
10" American Brass Cymbal	Stayon Tom Tom Holder
Ideal Drum Stand	Chinese Wood Block
12" Genuine Zenjian Cymbal (thin)	Wood Block Holder
Stayon Non-Swing Cymbal Holder	Bass Drum Tone Control
	Wire Brushes—Wood Handles
	Pair H-16 Hickory Drum Sticks
	Beginner's Drum Method

No Substitutions or Omissions

THE NEW YORKER "FULL DRESS" OUTFIT

NEW YORKER OUTFIT IN MARINE PEARL AND NICKEL

No. 5349 - \$127.00

In this fine set-up Leedy offers practicability, appearance and value in full measure. The items were selected with a view to efficiently serving the "all 'round" jobbing Drummer who cannot carry more, but who at the same time desires a fine looking outfit of essentials. The "New Yorker" is also a wonderful outfit for the school orchestra Drummer who is just starting out to do professional playing. Of course, as in the case of all outfits, traps and accessories may be added as needed. However, the drums and other main items will last for years if properly cared for. No Drummer will ever regret choosing this outfit—the quality, the appearance and the price make it a real buy.

CHOICE OF EIGHT FINISHES

With All Metal Parts Heavily Nickel Plated

Sparkling Gold	No. 5348	\$127.00
Marine Pearl	No. 5349	127.00
Oriental Pearl	No. 5356	127.00
Black Pearl	No. 5351	127.00
Sparkling Green	No. 5352	127.00
Black Elite	No. 5353	99.00
White Elite	No. 5354	97.00
Blue Tri-Tone (Inlaid Hoops)	No. 5357	100.00

With Metal Parts in Chromium or Nobby Gold \$24.75 Extra

THE NEW YORKER OUTFIT—SET UP AS FOLLOWS

5" x 14" Broadway Standard Floating Head Snare Drum	10" Chee Foo Chinese Tom Tom Stayon Tom Tom Holder
14" x 28" Spartan Single Tension Bass Drum	Chinese Wood Block
Professional Pedal with Spurs and Cymbal Holder	Wood Block Holder
10" American Brass Cymbal	Castanets on Handle
Ideal Drum Stand	8" Tambourine
13" Genuine Zenjian Cymbal (thin)	Wire Brushes—Wood Handles
Stayon Non-Swing Cymbal Holder	Bass Drum Tone Control
	Pair H-16 Hickory Drum Sticks
	Beginner's Drum Method

No Substitutions or Omissions

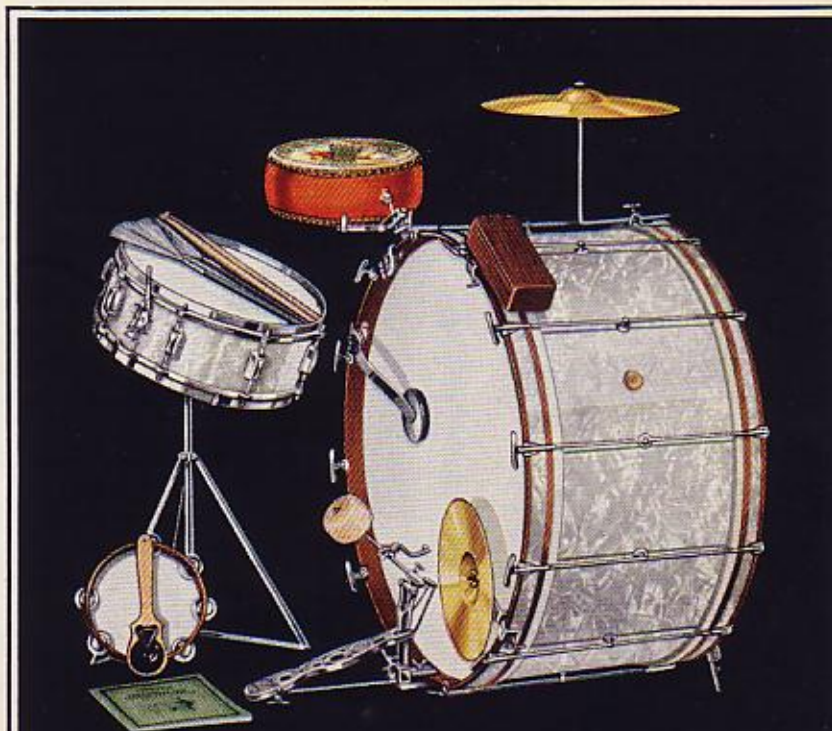

THE BLACK (OR WHITE) SPECIAL OUTFITS

THESE OUTFITS SUPPLIED IN NICKEL ONLY

IN BLACK—No. 5461

IN WHITE—No. 5464

\$75.00

The Black (or White) Special Outfit has been recently improved and now this assembly is more popular than ever. Its snappy, up-to-the-minute appearance, its appeal from the utility standpoint, its high quality and its outstanding value at the \$75.00 price cannot be duplicated on the market. You get more for your money here than in any group equipment ever offered. Note the items in the set-up as they are listed below and you cannot fail to be convinced of our claims. Both outfits are identical in equipment, but you have a choice of having the drums finished either in the lustrous ebony-black or the gleaming snow-white lacquers.

The Black and the White Special Outfits were assembled to meet the requirements of the average job, and nothing that you don't need is included. You can choose either outfit as a starter, and add to it as your needs increase. Choosing a complete outfit like this at the start saves you several dollars that you would pay if buying each item separately.

CHOICE OF TWO FINISHES

In Black No. 5461

In White No. 5464

\$75.00

Either Outfit Supplied with 14"x28" Bass Drum at \$4.00 Extra

BOTH OUTFITS SET-UP AS FOLLOWS—IN NICKEL ONLY

5"x14" Reliance All-Metal (8 Rods)

Separate Tension Snare Drum

12"x26" Reliance Single Tension

Bass Drum

Light-Weight Pedal with Spurs

and Cymbal Holder

10" American Brass Cymbal

Ideal Drum Stand

11" Genuine Zenjian Cymbal

12" Sizzle Cymbal

2 Stayon Non-Swing Cymbal

Holders

10" Chee Foo Chinese Tom Tom

Stayon Tom Tom Holder

Chinese Wood Block

Wood Block Holder

Wire Brushes—Wood Handles

Bass Drum Tone Control

Pair H-16 Hickory Drum Sticks

Beginner's Drum Method

No Substitutions or Omissions

SCENES AND SILHOUETTES FOR BASS DRUM HEADS

Leedy Painted Scenes and Silhouettes for Bass Drum Heads enjoy the reputation of being far superior to the usual work of this kind. Only talented and experienced artists are employed. The stipple process of "brushing" eliminates all brush marks, therefore there are none to show thru when interior lights are used. This gives a painting much the same effect as seen in stained glass windows.

SPECIAL SCENES AND LETTERING

Special scenes, figures, lettering or designs will be painted to order from sketches, photos or pictures taken from magazines. The same skilled artistry, special paints and exacting care will be employed as on regular scenes and silhouettes.

PAGE 23

ettes. One to two weeks will be required on such orders. Prices on this special work will be quoted upon receipt of copy and full information as to drum head size, etc.

INTERIOR BLINKER LIGHTS FOR BASS DRUMS

Colored blinker lights will add the finishing touch of beauty to your "Full Dress" outfit. Mounted inside the shell so that the drum vibration will not break the lamp filaments. Socket in shell permits detaching the cord for packing.

No. 1747—Two different colored lights, with blinker attachment, 12 ft. cord, socket and plug.
Installed\$7.50

TEN PAINTED BASS DRUM SCENES (FIVE NOT SHOWN)

**PRICES
DO NOT INCLUDE
DRUM HEAD,
TUCKING OF HEAD
OR FLESH HOOP**

No. 6700—The Harlequin Girl—Full Color	\$10.00
No. 6703—The Butterfly Girl—Full Color	10.00
No. 6721—The Sentinel Silhouette—An Indian on Horseback	10.00
No. 6723—The Butterfly Silhouette—A Nude Girl as a Butterfly	10.00
No. 6724—Japanese Silhouette—Famous Fujiyama Mountain Scene	10.00

**PLEASE
STATE DIAMETER
OF YOUR
BASS DRUM SHELL
ONLY**



DUTCH WINDMILL

No. 6702 \$10.00



SHIP SILHOUETTE

No. 6722 \$10.00



BATHING GIRL

No. 6701 \$10.00



SPIDER WEB GIRL

No. 6720 \$10.00



MOONLIGHT SILHOUETTE

No. 6704 \$10.00

ORCHESTRA MODELS

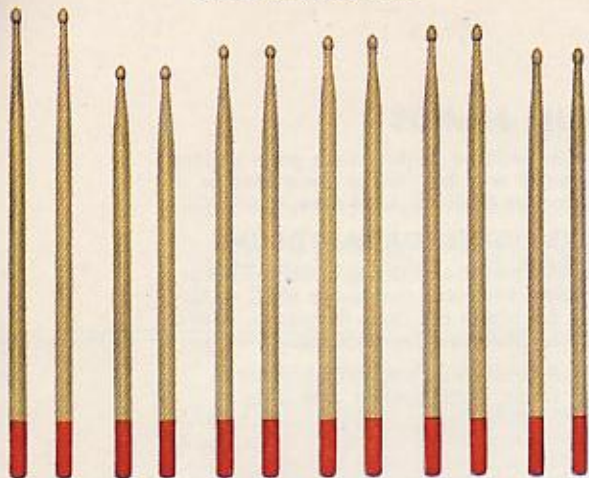

RE 10 RE 11 RE 12 RE 13 RE 14 RE 15

BAND and DRUM CORPS MODELS

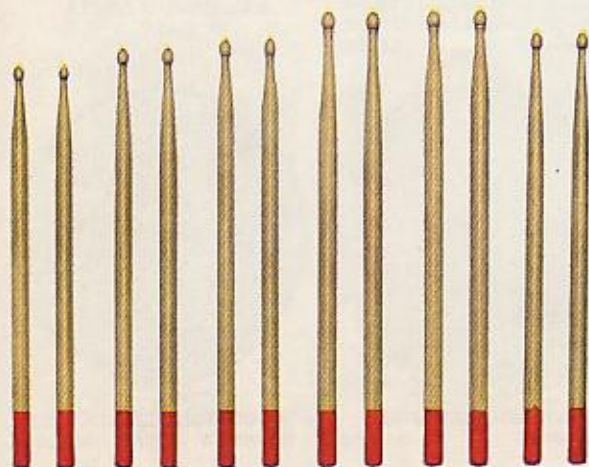

RE 16 RE 18 RE 19 RE 20 RE 22 RE 23

THE WORLD'S FINEST

Leedy

LEEDY "RED END" DRUM STICKS

EXTRA FINE MODELS FOR PARTICULAR DRUMMERS

The Red End on these sticks is the means of identifying extra fine selected models made especially for particular Drummers who insist on having the very best obtainable. It is the stick itself that is better—a combination of the highest quality selected straight-grained, second growth hickory, and the most careful workmanship that money can buy. The instant you pick up a pair you will experience a new "feel" of confidence and know instinctively that you have a stick superior to all others. They not only have a more "classy" appearance, but also a smooth, hard, glass-like, high luster finish from end to end. Every stick is sanded, grain-filled and sprayed with clear Duco lacquer, then hand rubbed and sprayed again. They are matched for even weight and balance, and wrapped in Cellophane. Insist on Leedy Red End Sticks—they cost a little more but are well worth it. Ask any Drummer who uses them. He'll tell you they are superior to any other stick made.

TWELVE MODELS FOR ORCHESTRA, BAND AND DRUM CORPS

- No. RE 10—17" long, weight about 4¼ oz. per pair
- No. RE 11—14¾" long, weight about 3¾ oz. per pair
- No. RE 12—15½" long, weight about 3¾ oz. per pair
- No. RE 13—15¾" long, weight about 3½ oz. per pair
- No. RE 14—16" long, weight about 3¾ oz. per pair
- No. RE 15—15¾" long, weight about 3 oz. per pair
- No. RE 16—15" long, weight about 3¾ oz. per pair
- No. RE 18—15½" long, weight about 5 oz. per pair
- No. RE 19—16" long, weight about 4¼ oz. per pair
- No. RE 20—17" long, weight about 5½ oz. per pair
- No. RE 22—17" long, weight about 5¾ oz. per pair
- No. RE 23—16" long, weight about 3¾ oz. per pair

75c
PER PAIR

Please Order by Both Number and Letters

Any of the Above Models in Your Choice of Duco Colors, Including Black or White, (to order) per pair\$1.00

Regular Hickory, Snakewood and Rosewood Models on Page 54.

**GENUINE LEEDY STICKS ARE TRADEMARKED "LEEDY"
INSIST ON GENUINE LEEDY STICKS FOR GREATER PLAYING EASE**

THE "BROADCASTER" OUTFIT

Here is a wonderful complete outfit that will "fill the bill" on practically any radio broadcast or dance job that you will be called upon to play. Note the drum sizes, the cymbal set-up and the trap board with its splendid array of traps. Here indeed is an outfit that you will be proud to own and to play. Not a "Full Dress" finish outfit, to be sure, but one that "has everything" with no unnecessary "frills" or "excess." You'll have occasion to use every one of the items listed below, and you'll be glad to have them when you need them. To look at the outfit is to marvel at the fact that the price is only \$92.00—for everything. And if you prefer a 14"x28" bass drum instead of the 12"x26" size as shown in the listing, you can get it at an extra cost of only \$4.00 as indicated below. You can't go wrong by choosing the "Broadcaster"—it offers as big a value for the money as you will be able to get anywhere.

AS ILLUSTRATED ONLY

No. 5467 \$92.00

With a 14"x28" Reliance Bass Drum \$4.00 Extra

THE "BROADCASTER" OUTFIT—SETUP AS FOLLOWS

5"x14" Reliance All Metal Snare Drum, 8 Rods, Separate Tension, Nickel.
 12"x26" Reliance Mahogany Single Tension Bass Drum, Nickel
 Light-Weight Pedal, Spurs and Cymbal Holder
 10" American Brass Cymbal
 Ideal Drum Stand
 Trap Board
 13" Genuine Zenjian Cymbal (Thin)
 Stayon Non-Swing Cymbal Holder
 12" Chinese (choke) Cymbal
 8" American Brass (choke) Cymbal
 Stayon Choke Cymbal Holder
 10" Chee Foo Chinese Tom Tom
 Stayon Tom Tom Holder

Chinese Wood Block
 Wood Block Holder
 Castanets on Handle
 8" Tambourine
 8" Triangle
 Triangle Holder
 Bock-a-da-Bock Cymbals
 Wind Whistle
 Song Whistle
 Midget Slap Stick
 Pair Sand Blocks
 Sleigh Bells
 Synco-Jazz Brushes (Wood Handles)
 Bass Drum Tone Control
 Pair H-16 Hickory Drum Sticks
 Beginner's Drum Method

No Substitutions or Omissions

THE "BROADCASTER" OUTFIT AS ILLUSTRATED

No. 5467 — \$92.00

With All Metal Parts Heavily Nickel Plated





THE DANSANT OUTFIT

The new Dansant Outfit is carefully and correctly assembled of standard high quality Leedy items, and is practical for either the professional or semi-professional Drummer. The snare drum is our 5"x14" Reliance Separate Tension model—the size supplied in all higher priced outfits—and the bass drum is the 12"x26" Reliance Single Tension model, which is big enough for almost any type of job you may have to play and yet small enough to be transported easily. The balance of the outfit includes the main essentials—a practical outfit at a very low price.

SET-UP AS FOLLOWS—NO SUBSTITUTIONS OR OMISSIONS

5"x14" Reliance All Metal Snare Drum, Separate Tension, Heavily Nickelled Rods and Strainer.	Ideal Drum Stand.
12"x26" Reliance Single Tension Bass Drum, Nickel Plated Rods.	11" Genuine Zenjian Cymbal (Thin). Stayon Non-Swing Cymbal Holder.
Light-Weight Pedal, Spurs and Cymbal Holder.	Chinese Wood Block.
10" American Brass Cymbal.	Wood Block Holder.
	Pair H-14 Hickory Drum Sticks.
	Synco-Jazz Brushes (Wood Handles)
	Beginner's Drum Method.

No. 5471—Dansant Outfit, Complete	\$65.00
Above Outfit with 14"x28" Bass Drum	\$4.00 Extra



THE ACE OUTFIT

The Ace Outfit shown here is carefully assembled of high grade items made from the best materials, and is particularly adapted to home or school use. The drums are large enough for small orchestras and will give long, satisfactory service. The outfit is low in price, good looking, and easy to transport. An excellent "set-up" for the beginner who wants something a little better than either of those shown on the next page. A beginner's instruction book is included among the items listed below.

SET-UP AS FOLLOWS—NO SUBSTITUTIONS OR OMISSIONS

4"x14" Pep Snare Drum. Nickel.	11" Genuine Zenjian Cymbal (Thin).
8"x24" Reliance Single Tension Bass Drum, Nickel Plated Rods.	Stayon Non-Swing Cymbal Holder.
Light-Weight Pedal, Spurs and Cymbal Holder.	Chinese Wood Block.
10" American Brass Cymbal.	Wood Block Holder.
Ideal Drum Stand.	Pair H-12 Hickory Drum Sticks.
	Synco-Jazz Brushes (Wood Handles).
	Beginner's Drum Method.

No. 5475—Ace Outfit	\$50.75
---------------------------	---------

THE CAMPUS OUTFIT

This outfit will well serve the young Drummer in both the small school orchestra and the home. It is ideal for accompanying the piano, the phonograph, or the radio. Hours of wholesome recreation for the boy or girl who is rhythmically inclined, and very instructive as well. The drums and other articles are all of the highest quality materials and large enough to give the youngster the feeling of "professionalism". It is not hard to learn to drum—Drumming is Rhythm—Rhythm is inherent in everyone—it is the foundation of all music and worthy of study.

SET-UP AS FOLLOWS—NO SUBSTITUTIONS OR OMISSIONS

- | | |
|--|------------------------------------|
| 3½"x13" Nifty All Metal Snare Drum, Nickered Shell and Rods. | 12" Chee Foo Chinese Crash Cymbal. |
| 8"x24" Reliance Single Tension Bass Drum, Mahogany Shell, Nickel Rods. | Stayon Goose Neck Cymbal Holder. |
| Light-Weight Pedal, Spurs and Cymbal Holder. | Chee Foo Chinese Wood Block. |
| 8" American Brass Cymbal. | Wood Block Holder. |
| Junior Snare Drum Stand. | Synco-Jazz Brushes (Wood Handles). |
| | Pair H-12 Hickory Drum Sticks. |
| | Leedy Beginner's Drum Method. |

No. 5481—Campus Outfit\$42.50

THE OUR GANG OUTFIT

Here is a dandy little outfit that is high grade in every respect and at a most reasonable price. The instruments are not toys in any sense, but sturdy throughout and built of the finest raw products. Fashioned to the need of the youngster who aspires to drumming, and to the purse of the parents who want to encourage the child's rhythmic instinct. This outfit will liven up the young and old alike—it will take the "dull" out of many an evening at home and lead to a greater appreciation of music.

SET-UP AS FOLLOWS—NO SUBSTITUTIONS OR OMISSIONS

- | | |
|---|------------------------------------|
| 3"x12" Junior Orchestra Snare Drum, Red Shell, Black Hoops and Nickel Rods. | Junior Snare Drum Stand. |
| 8"x22" Junior Single Tension Bass Drum, Red Shell, Black Hoops and Nickel Rods. | 10" Chee Foo Chinese Crash Cymbal. |
| Light-Weight Pedal, Spurs and Cymbal Holder. | Stayon Goose Neck Cymbal Holder. |
| 8" American Brass Cymbal. | Chee Foo Chinese Wood Block. |
| | Wood Block Holder. |
| | Pair Junior Hickory Drum Sticks. |
| | Synco-Jazz Brushes (Wood Handles). |
| | Beginner's Drum Method. |

No. 5485—Our Gang Outfit\$33.50

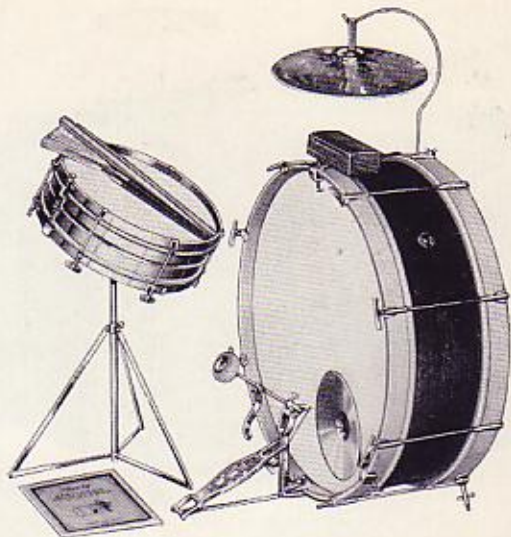

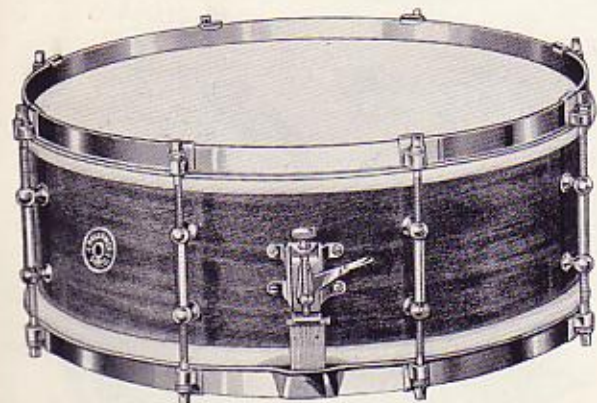
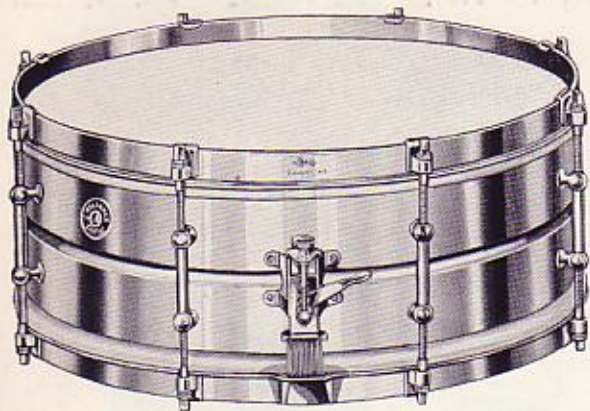
**THE RELIANCE ALL METAL DRUM****8 Rods****Flanged Counter Hoops****Separate Tension**

The Reliance Model has for many years been the leader of the popular price field. Note that we have recently improved this drum by putting on flanged counter hoops and eight separate tension rods in place of the former six—at NO increase in price. These two additional rods mean that it is possible to obtain more even head tension, which in turn results in more sensitive snare action and easier playing qualities. An excellent drum for either the professional or school Drummer. Strong spun brass seamless shell of practically the same quality as on our highest grade models with reinforcing "bead" and heavily nickel plated. Finely matched calf heads, silk wire wound snares and the Leedy "Presto" Muffler Snare Strainer. Truly the finest drum available at anywhere near this price and one that will give the best of service under hard usage.

Made In One Size Only

No. 3002—5"x14" \$22.50

Not Supplied in "Full Dress" Finishes

THE RELIANCE WOOD SHELL DRUM**8 Rods****Flanged Counter Hoops****Separate Tension**

And here we present the Reliance Model with a wood shell—made of 3-ply laminated, finely finished, best quality mahogany. For Drummers who prefer the wood shell drum there is nothing on the market that can equal this instrument at the price. Like the metal shell Reliance described above, this drum is now equipped with flanged counter hoops and eight (instead of six) separate tension rods, which means a more snappy tone and easier playing qualities. This is due to the fact that the heads can be tensioned to a greater degree of evenness over every square inch of the surface. All other parts, such as heads, muffler snare strainer, hoops, rods, etc., are of best quality materials the same as used on the all-metal Reliance. Both models shown on this page are more for the money than any \$22.50 drum ever offered. Not many years ago—such drums were priced at \$32.50.

Made In One Size Only

No. 3006—5"x14" \$22.50

Not Supplied in "Full Dress" Finishes

UTILITY ALL METAL SNARE DRUM

Nickel Plated

Muffler Snare Strainer

Six Separate Tension Rods

Here is the new "leader" of the low-priced orchestra drum field. A "most for the money" instrument that jumped to the fore in record time because of its high quality, plus the most reasonable retail price ever attached to a drum of this calibre. The shell is made of the same high grade brass, spun with double inside reinforcing flanges (edge of shell not turned over wire) and seamless, as used on all of our higher priced models. There are six separate tension, square head rods, flat type steel counter hoops and throw-off muffler strainer. The heads are the famous "Hardwhite" for batter side and "Slunk Calf" for snare side. Silk wire wound snares. Every part is carefully assembled to give the best possible tonal and easy-playing qualities. All metal parts heavily nickel plated. A very fine appearing drum.

Not Made In "Full Dress" Finishes

No. 3010—5"x14"—One Size Only\$17.50

UTILITY WOOD SHELL SNARE DRUM

3-Ply Laminated Shell

Muffler Snare Strainer

Six Separate Tension Rods

Everything about this model is exactly the same as the above drum excepting the shell, which is made of 3-ply laminated wood with extra heavy reinforcing hoops. Positively guaranteed not to warp or crack. The finish is a rich mahogany. This drum has six strong square head, separate tension rods, and flat type steel counter hoops. Genuine "Hardwhite" batter and "Slunk Calf" heads and silk wire wound snares are other features. You will like either the metal or wood shell Utility models. They have fine tone, fine appearance, plenty of volume, sensitive response, and easy playing qualities such as usually found only in drums of a much higher price.

Not Made In "Full Dress" Finishes

No. 3012—5"x14"—One Size Only\$17.50

DRUM CORPS DRUMS and ACCESSORIES

Are not listed or shown in this catalog. Send for our 72-page book, the "Roll-Off", the most complete Drum Corps Catalog and text book ever published. Mailed free and postpaid on receipt of your request.

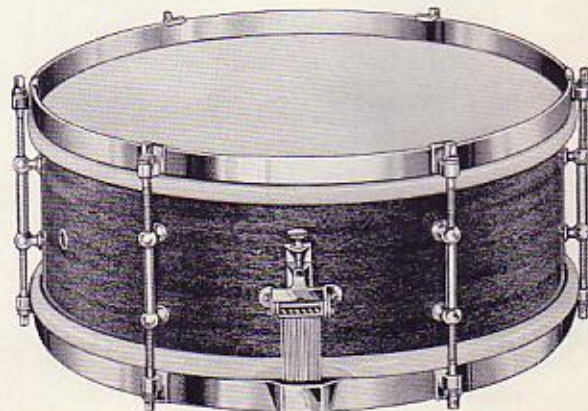

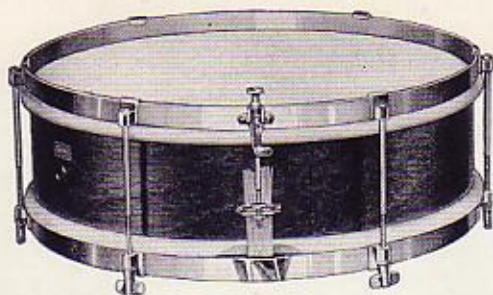
**PEP SNARE DRUM**

3-Ply Laminated Shell 6 Rods Muffer Snare Strainer

This snare drum is designed along professional lines, with every part built of the very best quality materials. A very efficient little instrument for small orchestra in the school or home. It has a laminated shell with a rich mahogany finish, six thumb screw rods, a practical muffer snare strainer, silk wire wound snares and good quality genuine calf heads. The metal parts are all heavily nickel plated. A drum that presents a nice appearance and has good drumistic qualities in every respect, and which will give a lot of real service at a very low price.

Made In One Size Only

No. 3125—Size 4"x14"\$12.50

NIFTY ALL METAL SNARE DRUM

Nickel Plated 6 Rods Muffer Snare Strainer

A most durable, low priced snare drum. Admirably suited to the young boy or girl for use in the school orchestra or home. The strong all metal shell is further strengthened by a reinforcing bead which, together with its six thumb screw rods, fine genuine calf heads, improved muffer snare strainer and silk wire wound snares, makes this a very practical instrument for use in the junior field. All metal parts are nickel plated. This instrument has a very snappy tone and fine appearance in every respect.

Made In One Size Only

No. 3131—Size 3½"x13"\$10.00

NIFTY WOOD SHELL SNARE DRUM

3-Ply Laminated Shell 6 Rods Muffer Snare Strainer

This is the same drum as the Nifty All Metal model shown above except that the shell is of 3-ply laminated wood strongly reinforced and finished with a rich, highly polished mahogany surface. It has six thumb screw tension rods, fine quality genuine calf heads, an improved muffer snare strainer and silk wire wound snares. All metal parts are nickel plated. Sturdily and durably built and has a real snappy drum tone. This model will prove highly satisfactory for the young drummer in the school orchestra and in the home. A splendid quality drum at a low price.

Made In One Size Only

No. 3130—Size 3½"x13"\$10.00

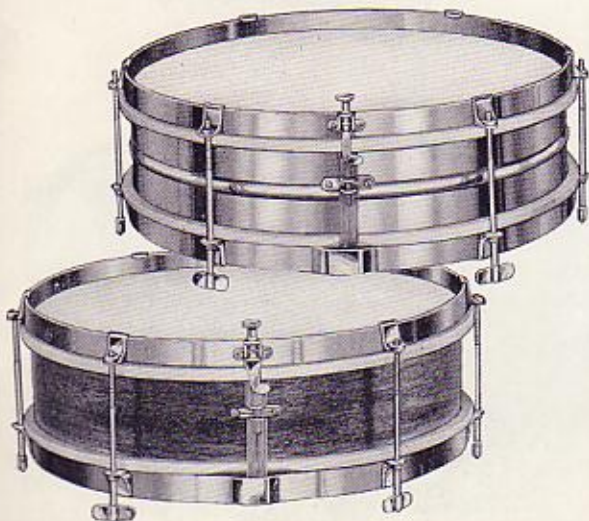

JUNIOR ORCHESTRA DRUM**Wood Shell, Red Duco Sticks and Sling Included Black Duco Hoops**

Here is a well designed, snappy and sturdy drum for the young boy or girl drummer who plays in the school orchestra or to the accompaniment of the radio, phonograph or piano in the home. This drum is not a toy in any sense of the word, but a strongly built and finely finished instrument with red Duco shell and black hoops; high grade calf heads, silk wire wound snares and a reliable snare strainer. A real drum value.

No. 3995—Size 3"x12" Only\$6.00

JUNIOR PARADE DRUM**Wood Shell, Red Duco Sticks and Sling Included Black Duco Hoops**

This drum is designed and made exactly like the drum shown above, but has a deeper shell for greater volume necessary for juvenile band and drum corps work in the school. This drum is not a toy, but a sturdy, high quality instrument that will give real service and satisfaction. The shell is attractively finished in red Duco, with black counter hoops, forming an effective contrast. The six thumb screw rods are heavily nickel plated; the heads of good quality calf. Quality silk wire wound snares.

No. 3996—Size 7"x12" Only\$7.50

JUNIOR PARADE BASS DRUM**Wood Shell, Red Duco Stick and Sling Not Included Black Duco Hoops**

This bass drum is the mate to either of the two drums shown above. Designed along the same principles and made with a red Duco shell and contrasting black hoops. Large enough for junior orchestra use and yet of a size and weight that can be carried easily by the small boy in a band or drum corps. It is a quality instrument and in no sense a toy. The thumb screw rods are of pressed steel, strong and heavily nickel plated. The heads are genuine good quality calf. Constructed of good materials throughout, this drum will give long and excellent service.

No. 5295—Size 8"x22" Only\$15.00

For choice of Other Duco Colors on the Shells and Hoops of These
Drums Add to the Prices Shown Above\$1.50

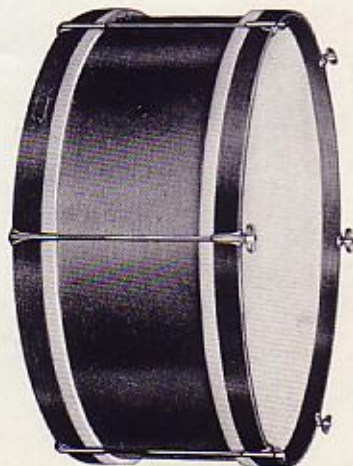

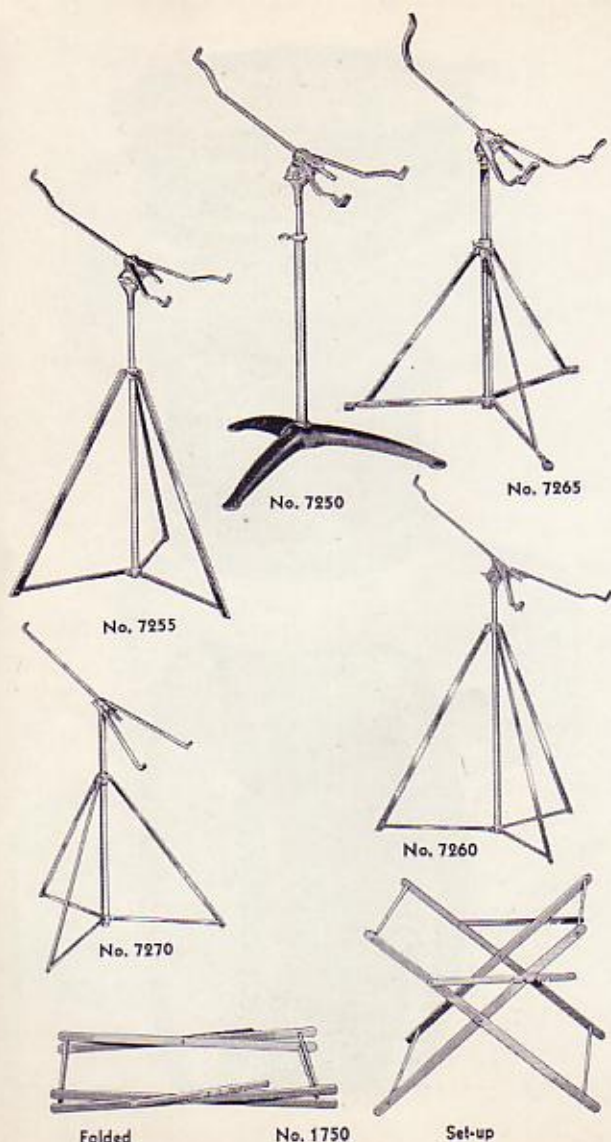
**CONCERT DRUM STAND**

Your drum will not wobble on this stand. Stronger and slightly heavier than any other on the market. A real comfort for the drummer who plays in the theatre pit and with concert bands or symphony orchestras. Molded steel base deeply threaded for brass tube. Easily taken apart.

No. 7250—Nickel Plated	\$6.00
No. 7252—Chromium Plated	9.00
No. 7251—Nobby Gold	9.00

STANDARD DRUM STAND

The finest folding drum stand made. Has the same sturdy arms as the model above. Stronger and heavier legs and braces than on the Ideal model. Adjustable to height and angles. Will hold drum steady.

No. 7255—Nickel Plated	\$4.00
No. 7257—Chromium Plated	6.00
No. 7256—Nobby Gold	6.00

MARVEL DRUM STAND

Just the stand you have been looking for to protect the plating on your drum hoops. Rubber cushioned arms. Rubber feet prevent slipping.

No. 7265—Supplied in Nickel Only	\$6.00
--	--------

IDEAL DRUM STAND

A neat, light stand that is adjustable to height and angles. Adjustable parts are accurately machined. Strong, rigid, and folds compactly.

No. 7260—Nickel Plated	\$2.50
No. 7262—Chromium Plated	4.00
No. 7261—Nobby Gold	4.00

JUNIOR DRUM STAND

A light stand that is a surprising value for the price. Holds orchestra drums up to 14" diameter. Adjustable, and folds compactly for packing.

No. 7270—Supplied in Nickel Only	\$1.50
--	--------

FOLDING STEEL BASS DRUM RACK

Sturdy and strong. Cross braces telescope to hold any width bass drum. Also adjustable to height. Bass drum will not sway or wobble. Stand weighs only 10 lbs. and folds conveniently for packing and transporting.

No. 1750—Nickel Plated	\$6.00
------------------------------	--------

STANDARD BASS DRUMS

With the Famous Leedy Solid Shells

Recognized as the World's Finest Bass Drums

Leedy Solid Shell Bass Drums are world famous and recognized by Drummers everywhere as superior to all others for tone, appearance and wearing qualities throughout. They have enjoyed this distinction for over thirty years. They are constructed with extra heavy shells, counter hoops, flesh hoops and tympani model rods, therefore will stand up longer under hard usage than any other drum made. The Leedy "Standard" name plate on the shell is your assurance of the very finest quality materials and workmanship obtainable. Every drum is equipped with the famous "Hardwhite" heads; however, "Kafette" (clear) will be supplied at no extra charge if desired. Lustrous Black or White Duco shells and hoops furnished at no extra cost. Other sizes made to order.

SEPARATE TENSION RODS

	Nickel	Chromium	Nobby Gold
No. 5010—12"x26"	\$51.00	\$63.50	\$63.50
No. 5012—14"x28"	55.00	67.50	67.50
No. 5014—14"x30"	58.00	70.50	70.50
No. 5016—16"x30"	59.00	71.50	71.50
No. 5018—16"x32"	63.00	75.50	75.50
No. 5020—16"x34"	67.00	79.50	79.50

SINGLE TENSION RODS

	Nickel	Chromium	Nobby Gold
No. 5030—12"x26"	\$41.00	\$51.00	\$51.00
No. 5032—14"x28"	45.00	55.00	55.00
No. 5034—14"x30"	48.00	58.00	58.00
No. 5036—16"x30"	49.00	59.00	59.00
No. 5038—16"x32"	53.00	63.00	63.00
No. 5040—16"x34"	57.00	67.00	67.00

For Double Center Supports Add... 1.50 2.00 2.00

Stick or Sling Not Included

Blue Tri-Tone Shell Finish, or Black or White Duco on Shell and Hoops--No Extra Charge

Sparkling or Pearl Inlaid Counter Hoops only \$ 3.00 Extra
 Sparkling or Pearl Shell and Inlaid Counter Hoops 25.00 Extra
 Sparkling Two-Tone Diamond Decorations (see page 10).... 10.00 Extra

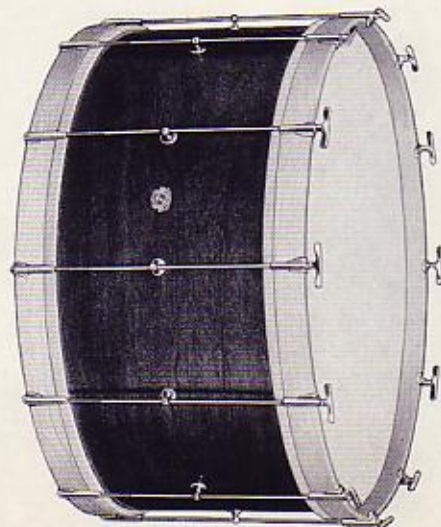
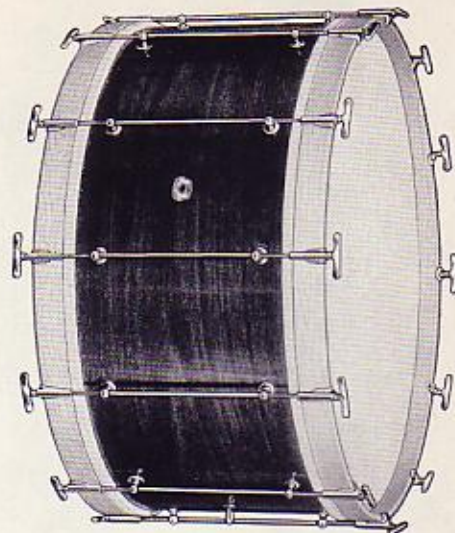

SPARTAN BASS DRUMS

Combining Maximum Strength With Minimum Weight

3-ply Laminated Shells

Finest Calf Heads

Tympani Model Rods

The Leedy Spartan Bass Drum is an exceptionally high quality instrument combining maximum strength with minimum weight. These qualities and the moderate price have made this model very popular with the Drummer who desires an instrument at a price midway between our Standard and Reliance. The Spartan is made with a 3-ply laminated shell—three layers of wood glued together so that the grain of each layer crosses that of the one next to it. This assures great strength, but light weight. The shell is guaranteed to hold its shape indefinitely and to give excellent satisfaction and long life. Equipped with the famous Leedy "Hardwhite" heads, maple counter hoops and sturdy tympani model rods exactly like those on the Standard models.

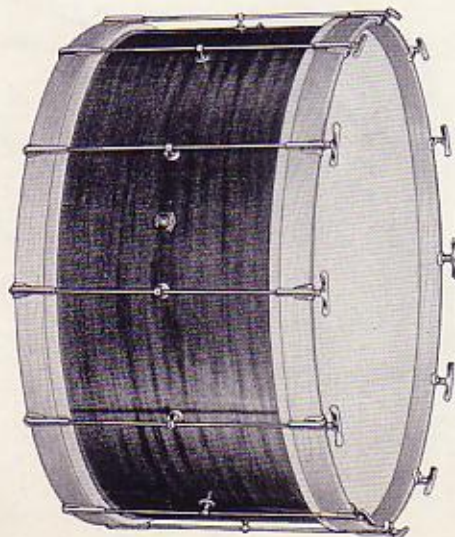
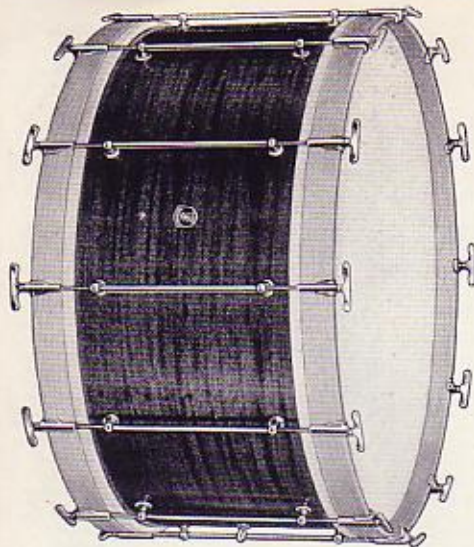

SEPARATE TENSION RODS

	Nickel	Chromium	Nobby Gold
No. 5110—12"x26"	\$41.00	\$53.50	\$53.50
No. 5112—14"x28"	45.00	57.50	57.50
No. 5114—14"x30"	48.00	60.50	60.50
No. 5116—16"x30"	49.00	61.50	61.50
No. 5118—16"x32"	53.00	65.50	65.50
No. 5120—16"x34"	57.00	69.50	69.50

SINGLE TENSION RODS

	Nickel	Chromium	Nobby Gold
No. 5130—12"x26"	\$31.00	\$41.00	\$41.00
No. 5132—14"x28"	35.00	45.00	45.00
No. 5134—14"x30"	38.00	48.00	48.00
No. 5136—16"x30"	39.00	49.00	49.00
No. 5138—16"x32"	43.00	53.00	53.00
No. 5140—16"x34"	47.00	57.00	57.00

For Double Center Supports Add ... 1.50 2.00 2.00

Stick or Sling Not Included

Blue Tri-Tone Shell Finish, or Black or White Duco on Shell and Hoops--No Extra Charge

Sparkling or Pearl Inlaid Counter Hoops only \$ 3.00 Extra
 Sparkling or Pearl Shell and Inlaid Counter Hoops 25.00 Extra
 Sparkling Two-Tone Diamond Decorations (see page 10).... 10.00 Extra

RELIANCE BASS DRUMS

The Lowest Priced Quality Bass Drum on the Market

Laminated Shells

Finest Calf Heads

Tympani Model Rods

In order to favor the demand for a very moderately priced bass drum, Leedy offers these fine Reliance models—positively the utmost for the money in tone, durability and appearance. They, like the Standard and Spartan, are made of the best materials. The lower price is only because a 2-ply laminated shell is used instead of 3-ply, and because there are two less rods on the comparative sizes. The same heavy reinforcing hoops, the same flesh and counter hoops and tympani model rods are used throughout. All heads are the regular Leedy "Hardwhite" calf, and the finish on the shell and hoops is of an excellent quality. Drummers will find Reliance Bass Drums to be a big value for the price.

SEPARATE TENSION RODS

No. 5210—8"x24"	\$32.00
No. 5212—12"x24"	34.00
No. 5214—12"x26"	36.00
No. 5216—14"x28"	40.00
No. 5218—14"x30"	43.00
No. 5220—16"x30"	44.00

SINGLE TENSION RODS—WITH CENTER SUPPORTS

No. 5230—8"x24"	\$22.00
No. 5232—12"x24"	24.00
No. 5234—12"x26"	26.00
No. 5236—14"x28"	30.00
No. 5238—14"x30"	33.00
No. 5240—16"x30"	34.00

SINGLE TENSION RODS—WITHOUT CENTER SUPPORTS

No. 5250—8"x24"	\$20.50
No. 5252—12"x24"	22.50
No. 5254—12"x26"	24.50
No. 5256—14"x28"	28.50
No. 5258—14"x30"	31.50
No. 5260—16"x30"	32.50

Stick or Sling Not Included

Choice of Duco Colors—One on Shell, Another on Hoops.....\$2.00 Extra

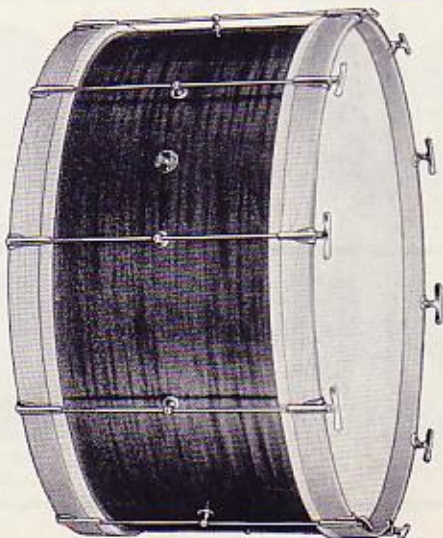
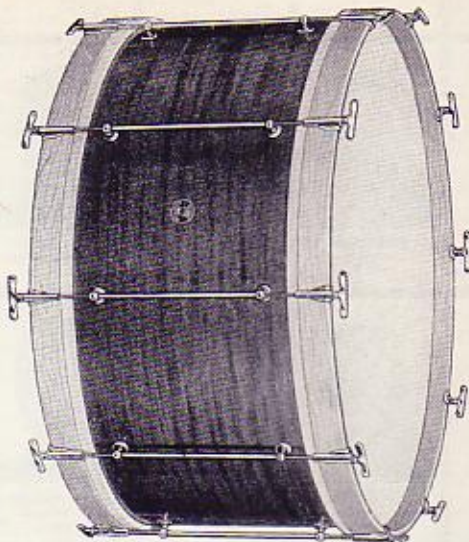



FRED S. PAINE
DETROIT SYMPHONY
BCPSTVK



Geo. A. BRAUN
METROPOLITAN OPERA
SYMPHONY-T



FRED E. ALRIGHT
R.A. BOLLE & N.Y. SYMPHONY
BOCA



HAROLD McDONALD
PARAMOUNT STRO-HOLLYWOOD
BCPSTVK



ART LAYFIELD
CHICAGO THEATRE
BCPSTVK



Geo. MARSH
FERD CRIFE'S ORCH.
BCPSTVK



GARY GILLIS
AIC LYMAN'S ORCH.
BCPSTVK



JOHN BAUGHANN
U. S. ARMY BAND
BCPSTVK



DICK RIGGELY
PITTSBURGH RADIO STAR
BCPSTVK



MURRAY SPIVACK
RKO STUDIOS, HOLLYWOOD
BCPSTVK



LARRY GOMAR
WICOM YOUNG'S ORCH. N. Y.
BCPSTVK



FRANK GARIELY
MONTREAL, CANADA
BCPSTVK



ARTHUR E. COOPER
DETROIT SYMPHONY ORCH.
BPT

That Thousands Of The World's Finest Professional Drummers Use Leedy Instruments For Their Most Exacting Needs In Every Type Of Work Is Indisputable Testimony Of The Superior Tone, Unexcelled Appearance And Fine Workmanship Of The Instruments Shown In This Catalog. We Are Sorry That Lack Of Space Does Not Permit Us To Show More Pictures Of Outstanding Leedy Users.



"HAPPY" REISS
RKO RADIO STAR, N. Y.
BCPSTVK



THOS. P. HAWKINS
LOEW'S OPHHELM, BOSTON
BCPSTVK



BOB PERRY
JERRY GREY'S ORCH., L. A.
BCPSTVK



L. C. GLUSKIN
GILSON'S ORCH., N. Y.
BCPSTVK



ALBERT GEO. RITTER
BOSTON SYMPHONY ORCH.
SYMPHONY-T



Geo. J. CAREY
CINCINNATI SYMPHONY ORCH.
BPTK



CHARLES L. WHITE
LOS ANGELES WIL. ORCH.
BCPSTVK



AL "RAGS" ANDERSON
COLUMBUS, OHIO
BCPSTVK



RALPH HAWKINS
LOEW'S OPHHELM, BOSTON
BCPSTVK



JAMES-JEROME WOSBERG
CINCINNATI SYMPHONY ORCH.
BCPSTVK



JOE W. SOISTMAN
BALTIMORE, MD.
BCPSTVK



CLIFF T. WILLIAMS
GLYDE MIDDY'S ORCH.
BCPSTVK



JOHNNY WERNER
LA PLAZA CAFE, DETROIT
BPTV



AMOS THOMPSON
KINGLINS BRASS BARRON SALLEY
COO



CHAUNCEY MORHOUSE
NEW YORK CITY
BCPSTVK



HARRY WOLFF
SCULLY SO. THEA., BOSTON
STV



EDWARD ANDRE
KEITH'S BOLTON THEA.
BCPSTVK



RICHARD BRUGATO
NEW YORK CITY
BCPSTVK



DUSTY ROADES
CARLEY ASKIN'S ORCH.
BCPSTVK



HOWARD MCELROY
ST. PAUL, MINN.
BPTVK



EVERETT CONWAY
WEST STATES ORGUS
BPT



Laurie MINCHINTON
NEW YORK CITY
BPTVK



VINCENT L. MOTT
PATERSON, N. J.
BCPSTVK



FRANK HOLT
MAYFIELD, MISS.
BOPE



TOMMY WHALEN
DUN KETTER'S ORCH.
BS



HOWARD GOULDEN
FREDERICK'S ORCH.
BOPTVX



FRANK A. SNOW
HERBERT L. CLARK BAND
BPTT



WALTER E. LIGHT
DENVER SYMPHONY ORCH.
BOPTVX



JOHN JOS. HENEV
ST. AUGUSTINE, FLA.
BOPSK



O. FRANKLIN ROMINGER
HERBERT L. CLARK BAND
COOTY



BILLIE HAMMOND
VINOUEVILLE XYLOPHONE ARTIST
X



RAY VAUGHN
VINOUEVILLE XYLOPHONE ARTIST
BPSX



CHESTER MARTIN
N. Y. PARAMOUNT THEATRE
BOOPTVX



HERMAN H. FINK
N. Y. PARAMOUNT THEATRE
BOPTVX



FRED NOAK
CINCINNATI SYMPHONY ORCH.
TYPANIST—T



GEO. TILLINGHAST
WASHINGTON, D. C.
BOPTVX

The Leedy Equipment Owned And Used By The Drummers Whose Pictures Appear On These Pages May Be Determined By Using The Following Legend:
B—Leedy Bass Drum
C—Leedy Chimes
O—Leedy Orch. Bells
P—Leedy Pedal
X—Leedy Xylophone or Marimba
S—Leedy Snare Drum
T—Leedy Tympani
U—Leedy Tunable Toms
V—Leedy Vibraphone



GEO. A. SMITH
OHAMA, WIS.
BOPTVX



BILL GILCHER
LOS ANGELES, CAL.
BOPTVX



SERGE FOCKLER
LIMA, OHIO
BOPTVX



HARRY UNDERWOOD
NEW YORK CITY
BY



L. L. ALLEN
LOS ANGELES, CAL.
BOPTX



SCHUYLER ALWARD
ST. LOUIS, MO.
BOPTX



CHAS. SEIBERT
SPRINGFIELD, ILL.
BOPTVX



HARRY MARSHARD
ROXBURY, MASS.
BOPTX



IRVING A. LAPIN
AL. GOODMAN ORCH.
BPTV



RALPH C. SPECIA
NEW YORK CITY
BPTVX



RUDY VAN GELDER
JERSEY CITY, N. J.
BOPTVX



LEON KNAPP
GRAND RAPIDS, MICH.
BOPTVX



ALBERT VENUTO
RHO VADDEVILLE
BOPTVX



DICK ULM
PULASKI, MISS.
BOPTVX



WALLIE GORDON
TOM CENNY'S ORCH.
BOP



CHAS. F. COOPER
DETROIT SYMPHONY
BOPTVX



GEO. G. JACKSON
ACE BRIGGS'S ORCH.
BOPV



TOMMY TIBBETS
BIG STEVENS, LOS ANGELES
BOPTX



HENRY V. PAULSEN
HOLLING BROOK, BARNUMS BALLEE
BPT



ERVIN R. KAISER
BIG STEVENS, LOS ANGELES
BOPTX



TED CAMPBELL
DETROIT, MICH.
BOPTV



RALPH S. HANSELL
DENVER, COLO.
BOPTX



SPENCER WALLACE
WYKESHA, WIS.
BPSX

THE FAMOUS "X-L" PEDAL

ACCLAIMED BY THOUSANDS OF LEADING PROFESSIONALS

Feather Action

Extremely Fast

Low in Price

The Leedy "X-L" Pedal has proven a real "hit" in the drum world. It was adopted by more high-class professionals during its first year on the market than any other new model ever made because it has everything that Drummers demand in a pedal . . . the utmost in speed—feather ease in action—no faltering—no friction—no side strain—and no "stiff spots" anywhere in the travel of the beater rod. Just clean-cut, smooth response without any extra effort whatever. It is scientifically designed and precision built of only the finest materials. The uprights and footboard are of cast aluminum. This facilitates speed of action, and makes it light in weight. The ball and socket principle in the beater shaft is a new departure in pedal mechanism giving that easy "foot flow" and perfect balance that has made this the greatest of all pedals. There are no delicate working parts to get out of order—everything is sturdily constructed so as to give long and satisfactory service. The tension spring can be adjusted to satisfy the particular "feel" that you like best. All the usual adjustable features, such as beater rod, cymbal striker and spring tension, are also incorporated. Finished in baked Black Duco, highly polished aluminum footboard and nickel metal parts.

Without Spurs and Cymbal Holder

No. 7010—Pedal in Black Duco and Polished Aluminum \$10.00

With Spurs and Cymbal Holder

No. 7014—Pedal in Black Duco and Polished Aluminum 11.50

GRIP-TITE SPURS

These drum spurs are of cast steel and have a sharp point and non-marring swivel clamp. Sturdy and serviceable.

No. 7111—In Nickel\$.75 No. 7113—In Chromium\$1.10

No. 7112—In Nobby Gold\$1.10

STAYON CYMBAL HOLDER

A very strong holder made of pressed steel. Clamps to the bass drum hoop with the non-marring Stayon clamp.

No. 7140—In Nickel\$.75 No. 7142—In Chromium\$1.10

No. 7141—In Nobby Gold\$1.10

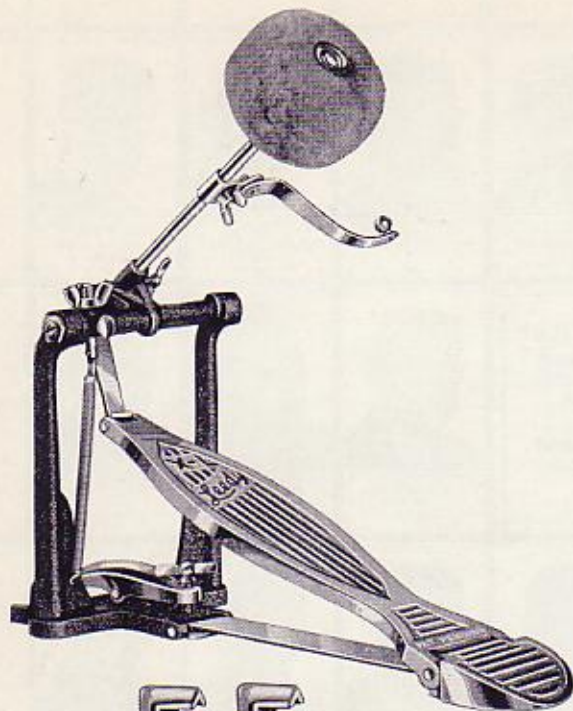

No. 7010

No. 7111



No. 7140

THE PROFESSIONAL PEDAL

A TIME TESTED FAVORITE IN THE PROFESSIONAL FIELD

"Relax" Footboard

Perfect Balance

Direct Stroke

The Leedy Professional Pedal (formerly called "The Fraser") needs but little praise. It has stood the test of time over a period of twenty years and is undoubtedly used by more professional Drummers than any other type. However, we emphasize the fact that it combines every good feature found on pedals in the same price class, also that all objectionable points have been eliminated. It is designed and built mechanically correct—that is, with all moving parts working on a direct line from the center. This assures freedom from wobbling, friction, side-strain and lost motion. All of which means perfect balance, permitting a maximum degree of speed with a minimum amount of effort. The "Relax" footboard does away with any possibility of leg fatigue. The pedal is made of malleable iron and pressed steel parts accurately machined and fitted. Light in weight and folds compactly. Heavily nickel plated and has complete spring, beater rod and cymbal striker adjustable features. You will like the "feel" of this pedal the minute you try it, and agree that it is the finest moderately priced pedal ever made.

No. 7020—Without Spurs or Cymbal Holder, in Nickel	\$ 7.50
No. 7022—Without Spurs or Cymbal Holder, in Chromium	11.00
No. 7025—With Spurs and Cymbal Holder, in Nickel	9.00
No. 7027—With Spurs and Cymbal Holder, in Chromium	13.50

GRIP-TITE SPURS

Made of cast steel with sharp points and non-marring swivel clamps. Strong, serviceable and thoroughly practical.

No. 7111—In Nickel	\$.75	No. 7113—In Chromium	\$1.10
No. 7112—In Nobby Gold		\$1.10	

STAYON CYMBAL HOLDER

A strong, pressed steel holder equipped with the new non-marring Stay-on clamp. Holder permits adjustment of cymbal.

No. 7140—In Nickel	\$.75	No. 7142—In Chromium	\$1.10
No. 7141—In Nobby Gold		\$1.10	

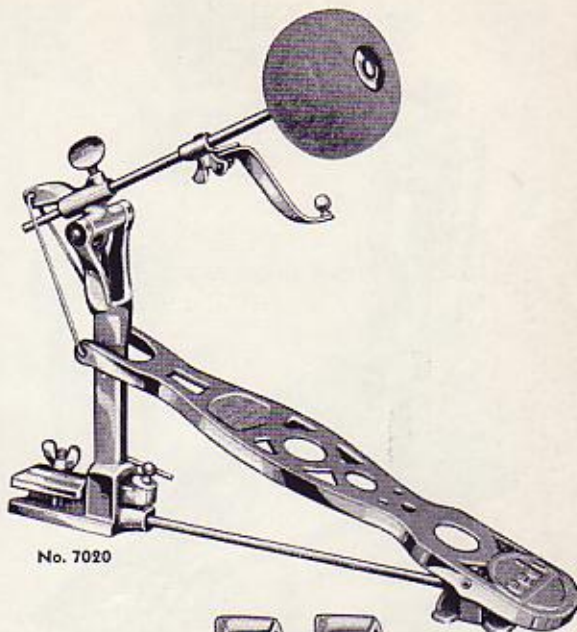

No. 7020

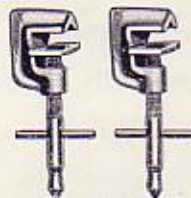

No. 7111



No. 7140

THE LIGHT WEIGHT PEDAL

SERVICE AND SATISFACTION ASSURED AT LOW COST

Easy Action

Direct Stroke

Ample Speed

The Light Weight Pedal includes all of the outstanding mechanical principles embodied in the Professional model shown on page 39. It is designed so that all parts work in a straight line from the center. This results in a direct stroke action, insuring a maximum of speed and ease of action. The pedal is mechanically balanced so that all wobbling, friction, side-strain and lost motion are eliminated. The tension spring is adjustable to get any desired "feel". The beater rod and cymbal striker are also adjustable. In fact, the only difference between this and the Professional Pedal is the slightly lighter construction. Weighs only 26 ounces—very strong, quick to set up and take apart, and folds compactly.

No. 7080—Without Spurs or Cymbal Holder, in Nickel\$6.00

No. 7082—Without Spurs or Cymbal Holder, in Chromium 8.50

No. 7085—With Spurs and Cymbal Holder, in Nickel 7.00

No. 7087—With Spurs and Cymbal Holder, in Chromium 9.50

LIGHT WEIGHT SPURS AND CYMBAL HOLDER

THE SPURS

CYMBAL HOLDER

Light, durable, and convenient with non-marring swivel clamp.

Made of pressed steel and 100% reliable. Has non-marring clamp.

No. 7120—Nickel, per pair\$.60

No. 7130—Nickel\$.60

No. 7122—Chromium, per pair .90

No. 7132—Chromium90

No. 7121—Nobby Gold, pair.. .90

No. 7131—Nobby Gold90

ABOUT BASS DRUM TONES AND PEDAL BEATER BALLS

Do you prefer the "Long Boom"—the "Short Boom" or the "Thud Boom" tone from your bass drum? The pedal balls shown here will give you any of the three qualities. Many Drummers are now equipped with all of them—with the pedal rod attached to each for quick changes. A very noticeable difference is effected between these beaters, even though the heads be left at the same tension.

No. 7055—Lambs Wool Ball and Rod for "Long Boom" Tone\$1.50

No. 7066—Brown Piano Felt Ball and Rod for "Short Boom" Tone 1.50

No. 7067—Solid Spanish Felt Ball and rod for "Thud Boom" Tone.. 1.50

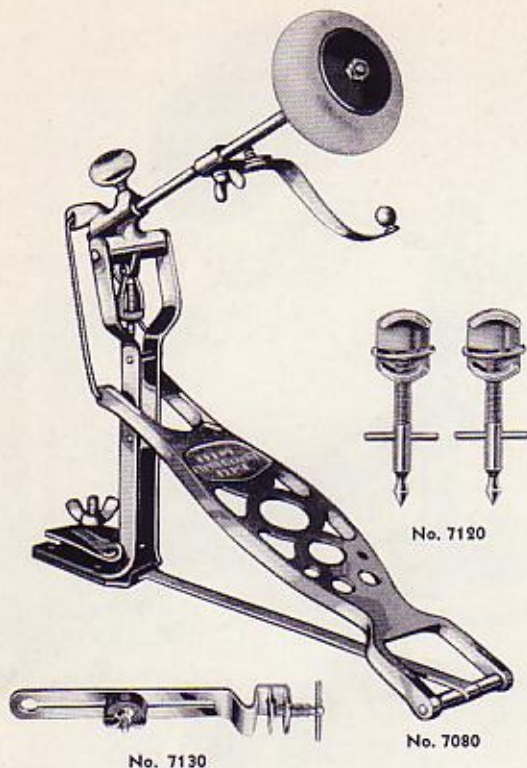

No. 7055



No. 7066



No. 7067

DISAPPEARING SPURS

WITH STEEL POINTS

These are "non-creeping" Spurs. The sharpened steel rods point straight downward—they do not strike the floor at any angle. Adjustable without disturbing hoop clamps. Do not have to remove from drum when traveling—merely loosen the thumb screw, slide the rods up out of the way and then tighten thumb screws again. They are convenient and save time. The strongest and finest spurs made.

No. 7100—Nickel Plated, Per Pair	\$1.50
No. 7102—Chromium Plated, Per Pair	2.25
No. 7101—Nobby Gold, Per Pair	2.25

WITH RUBBER POINTS

These are exactly the same as the spurs described above, but have rubber points instead of sharpened steel. Fine for use on cement and polished floors. They also improve the tone of your bass drum.

No. 7105—Nickel Plated, Per Pair	\$1.50
No. 7107—Chromium Plated, Per Pair	2.25
No. 7106—Nobby Gold, Per Pair	2.25

"X-L" PEDAL PARTS

No. 7175	\$2.25	No. 7181	\$1.50	No. 7187	\$.20
No. 717625	No. 718220	No. 718810
No. 717720	No. 718315	No. 7189	1.05
No. 717820	No. 718410	No. 719010
No. 7179	1.00	No. 7185	1.50	No. 719125
No. 718010	No. 718675	No. 719205

PROFESSIONAL PEDAL PARTS

No. 7040	\$2.50	No. 7046	\$.20	No. 7057	\$.20
No. 704120	No. 704710	No. 705875
No. 704210	No. 704875	No. 7059	1.05
No. 704315	No. 704920	No. 706160
No. 704420	No. 7055	1.50	No. 7062	1.50
No. 704515	No. 705610	No. 706405

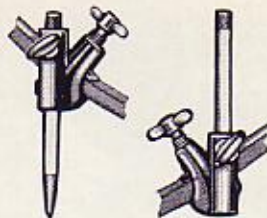

No. 7100

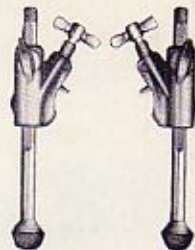

No. 7105

"X-L" PEDAL PARTS



PROFESSIONAL PEDAL PARTS

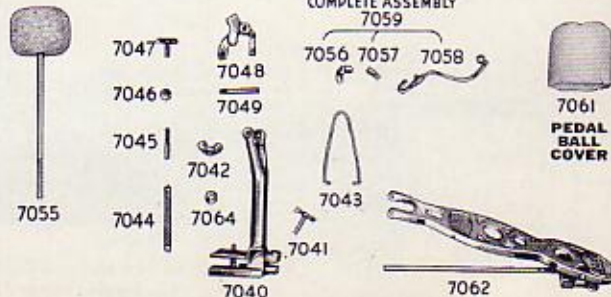

7061
PEDAL
BALL
COVER

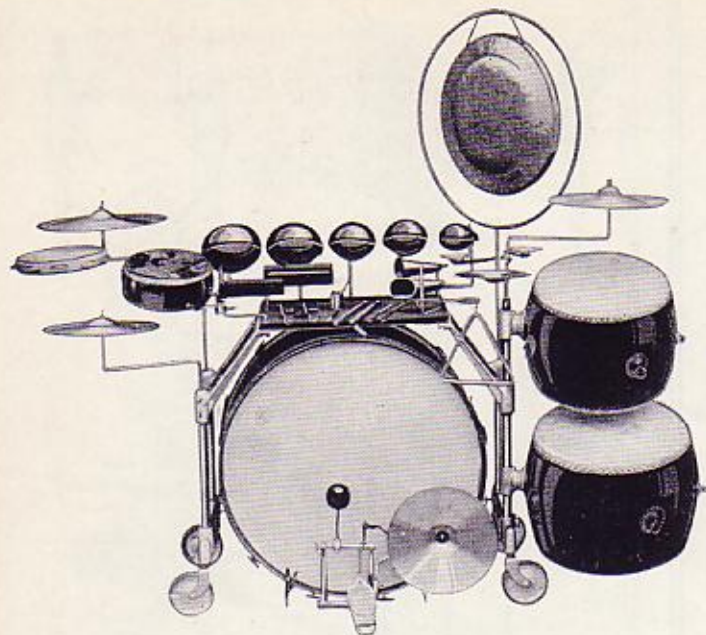

No. 7150 In Use

DOES NOT INCLUDE TRAPS ON TRAP HOLDERS

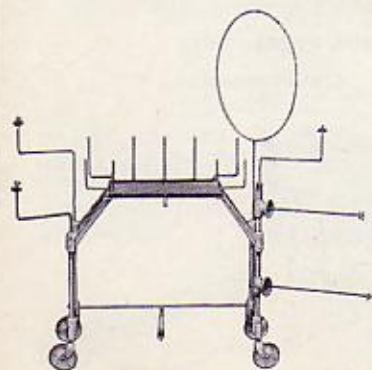

No. 7150

Knocks Down Compactly
Weights Only 45 Pounds

ROLLAWAY TRAP CONSOLE

**Bass Drum and All Rolls Away Like a Xylophone on Wheels
Your Traps Where You Want Them At All Times**

The Rollaway Trap Console is the most advanced type and also the most efficient trap holder ever invented. Built "Drummer Correct" in every detail, it is the last word in convenience and utility, to say nothing of its wonderful appearance. There is no end to the many different ways that the traps may be arranged—higher, lower, closer to you, or farther away. Even more holders and traps can be included than are shown in the illustration. The whole arrangement is especially designed for the Drummer who is compelled to move his outfit frequently. Just push the whole "works" an inch (or a hundred feet) as easily as you wheel a Xylophone. Very sturdy, thoroughly rigid and solidly built. The bass drum is so arranged that it remains in place and travels with the Console wherever the latter is moved.

The legs are made of strong tubing, staunchly cross-braced, and equipped with ball-bearing, rubber-tired wheels. The arms which hold the trap board are strong castings and the trap board itself is covered with high quality felt. All in all, the Rollaway Trap Console is made to give long, continuous and satisfactory service. Weighs only 45 lbs. when packed.

TRAP HOLDERS LISTED ON PAGE 45

- | | |
|--|---------|
| No. 7150—Console—Including Two Tom Tom Rods
but no Trap Holders—In Nickel | \$55.00 |
| No. 7152—Console—Including Two Tom Tom Rods
but no Trap Holders—In Chromium | 77.50 |
| No. 7151—Console—Including Two Tom Tom Rods
but no Trap Holders—In Nobby Gold | 77.50 |
| No. 7155—Console—Without Tom Tom Rods or Trap
Holders—In Nickel | 50.00 |
| No. 7157—Console—Without Tom Tom Rods or Trap
Holders—In Chromium | 72.50 |
| No. 7156—Console—Without Tom Tom Rods or Trap
Holders—In Nobby Gold | 72.50 |

TRAP TABLE

**A Place For Everything—Everything In Its Place
System, Neatness and Convenience Are Its Features**

This Leedy Trap Table was designed especially for the jobbing Drummer, but it became so popular that many who are playing permanent jobs are using it as well. It permits the placing of traps and cymbals in the most convenient positions for fast work, with a minimum amount of effort. And, best of all, it allows the use of a greater number of traps without clamping any of them to the bass drum hoop.

The Trap Table is strongly made and rests rigidly on the bass drum. It attaches easily and quickly to any size bass drum with the new non-marring Stayon clamps. It packs neatly into a small space for traveling. Made of three-ply basswood with three sides guarded by wood strips to keep sticks, etc. from falling off. Table is covered with good quality heavy felt, and measures 20" by 14". The weight is only 7 lbs. The bass drum hoop clamps fold under the table for convenience and ease of packing, and economy of space.

All cymbal and trap posts are interchangeable. This permits a great variety of cymbal and trap arrangements—with a little experimenting you will be able to arrange your traps and cymbals in a way that will be suited exactly to your own particular needs and preferences. The table makes an impressive appearance and is a real prestige builder.

Many noted drummers with nationally famous dance, theatre and radio orchestras use and endorse this Trap Table as the finest and most convenient light-weight trap arrangement on the market. You will like this convenient set-up too.

TRAP HOLDERS LISTED ON PAGE 45

- No. 7160—Trap Table Complete with Cymbal Holders and posts—Without Trap Holders—Nickel \$ 9.00
- No. 7162—Trap Table — Same as No. 7160, All Metal Parts in Chromium 13.00
- No. 7161—Trap Table — Same as No. 7160, All Metal Parts in Nobby Gold 13.00

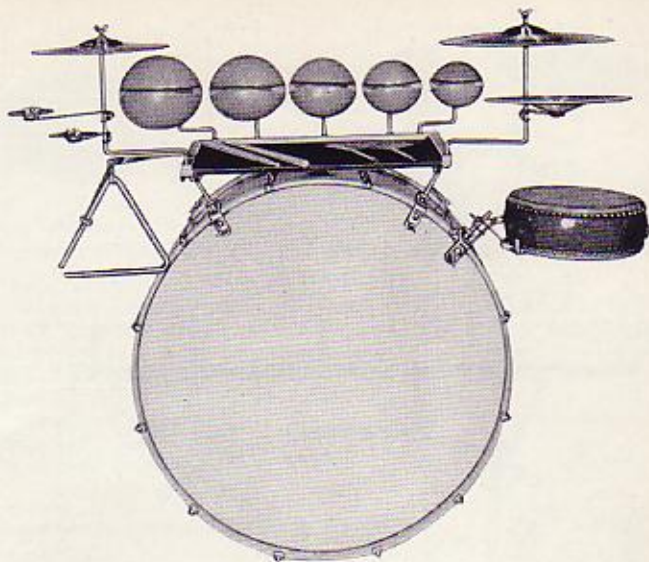

Trap Table With Traps

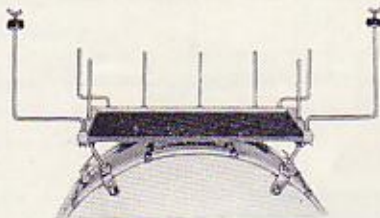

Trap Table Without Traps

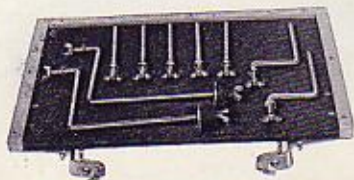

Trap Table Knocked Down For Packing



No. 7165 in Use

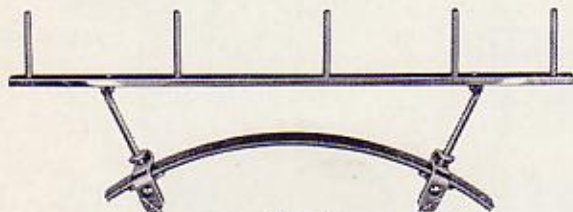

No. 7165

No. 7165 "Split" and Folded for Packing

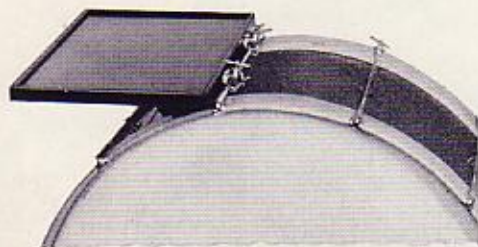
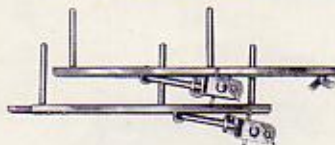

No. 7169

TRAP RAIL

A Wonderful Dance Set-up
With Stayon Clamps

Splits in the Middle for Packing
Light In Weight

The Trap Rail is another splendid original Leedy creation for either the jobbing or permanent Drummer. It has recently been improved by incorporating the new Stayon hoop clamps and by splitting the rail in the middle so that it may be carried with ease in a drum case. The Rail will hold many combinations of traps, cymbals, etc. other than shown in the accompanying photo. All trap holders for Trap Table and Trap Console as shown on page 45 will fit and may be used on the posts of the Trap Rail. There is no question but what any Drummer can do better work and get over the ground on "one nighters" with greater ease when he uses a Trap Rail. Besides, it gives the impression that a Drummer has brought along a bigger outfit than he really has. Another temple block may be arranged under the tom-tom (see illustration) and still another under the cymbal, making a set-up of five blocks on the rail if desired. The Rail is made of a horizontal channel steel bar which splits in the middle, with permanent upright steel posts. Fits any size bass drum.

TRAP HOLDERS LISTED ON PAGE 45

- No. 7165—Trap Rail Only, in Nickel\$5.50
 No. 7167—Trap Rail Only, in Chromium 7.50
 No. 7166—Trap Rail Only, in Nobby Gold.. 7.50

UTILITY TRAP BOARD

The Utility Trap Board clamps to a bass drum rod on either the right or left side and is supported by a non-marring felt padded wood block, which rests on the bass drum shell. The board is made of 3-ply wood nicely finished and covered with felt, and has raised edges to prevent traps from rolling off. Will hold a lot of traps and is excellent for jobbing. Strong, light in weight, and requires but little space when traveling.

- No. 7169—Utility Trap Board\$4.00

INTERCHANGEABLE POST TRAP HOLDERS

FOR USE WITH THE
Leedy Trap Console page 42 **Leedy Trap Rail** page 44
Leedy Trap Table page 43 **Leedy Hoop Adapter** page 46

Trap Holders are one of the most important "departments" of a Drummer's "business". All of those shown on this page are original Leedy creations, each one having been designed to do a particular job in the most efficient manner. They are "Drummer Correct" throughout and fill every necessary requirement inasmuch as they are **LIGHT, STRONG, FINELY FINISHED** and **ADJUSTABLE** to angles, heights and distances. A most outstanding feature of Leedy Trap Holders is that they are interchangeable; therefore may be used on the Trap Console, Trap Table, Trap Rail, or Hoop Adapter. This of course means a considerable saving for the Drummer who might change from a Trap Rail to a Table, from a Table to a Console, or vice versa.



No. 7200



No. 7205



No. 7210



No. 7230

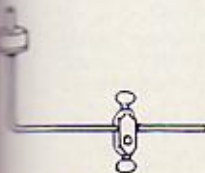

No. 7225

Temple Block Holder

No. 7200—Nickel	\$.75
No. 7202—Chromium	1.25
No. 7201—Nobby Gold	1.25

Wood Block Holder

No. 7205—Nickel	\$.60
No. 7207—Chromium90
No. 7206—Nobby Gold90

Small Tom Tom Holder

No. 7210—Nickel	\$.60
No. 7212—Chromium90
No. 7211—Nobby Gold90

Adjustable Tom Tom Holder

No. 7230—Nickel	\$1.10
No. 7232—Chromium	1.65
No. 7231—Nobby Gold	1.65

Non-Swing Cymbal Arm and Block

No. 7225—Nickel	\$1.50
No. 7227—Chromium	2.25
No. 7226—Nobby Gold	2.25

Afterbeat and Egyptian Cymbal Holder

No. 7215—Nickel	\$.60
No. 7217—Chromium90
No. 7216—Nobby Gold90

Triangle Holder

No. 7240—Nickel	\$.60
No. 7242—Chromium90
No. 7241—Nobby Gold90

Tambourine Holder

No. 7235—Nickel	\$.60
No. 7237—Chromium90
No. 7236—Nobby Gold90

Cow Bell Holder

No. 7220—Nickel	\$.15
No. 7222—Chromium25
No. 7221—Nobby Gold25

Large Tom Tom Rod (For Console Only)

No. 7245—Nickel	\$2.50
No. 7247—Chromium	3.75
No. 7246—Nobby Gold	3.75



No. 7215



No. 7240



No. 7235



No. 7230



No. 7245

THE NEW "STAYON" CLAMP NOW USED ON ALL LEEDY HOOP HOLDER CLAMPS

"Half a Turn And It's On To Stay"

This new clamp is the best ever. It has greater leverage than any yet devised, therefore it must have greater gripping power. This also means that it will not slip off the bass drum hoop and that your cymbals, tom toms, wood blocks, trap table, trap rail, etc. will remain as firm as the Rock of Gibraltar throughout any job you will have occasion to play. Even the vibration of your drum and the often extreme angle of a heavy trap will not jar this clamp loose. Several other fine features are embodied in this wonderful clamp . . . it will not mar a bass drum hoop to any noticeable extent—it only requires a half turn of the thumb screw to make it fast to the hoop—no undue force is necessary—no broken finger-nails—no bruised fingers. And it is the fastest clamp to put on or take off that has ever been made. The whole clamp is built into one unit—nothing to come apart or lose. The jaws work on a flexible rivet and are, therefore, a part of the main piece itself. Most of the trap holders on the following pages are equipped with "Stayon" clamps—the new foolproof, lifetime, sturdy clamp that makes good holders better for the Drummer who wants the best. The last word in efficiency.

"STAYON" HOOP ADAPTER FOR HOLDING TRAPS ON THE BASS DRUM HOOP

The "Stayon" Hoop Adapter is made to use with any of the Interchangeable Trap Holders shown on page 45, except Tom Tom Rod No. 7245. This device enables the Drummer to arrange traps on the bass drum at will, and eliminates the necessity of carrying a trap rail or trap table on a "hurry up" or "crowded" job. This Hoop Adapter, like all other Leedy bass drum hoop holders, has the new non-marring "STAYON" clamp. You'll like this new Hoop Adapter and the Leedy "Stayon" holders.

INTERCHANGEABLE TRAP HOLDERS LISTED ON PAGE 45

No. 7670—Stayon Hoop Adapter—in Nickel.....	\$.50
No. 7672—Stayon Hoop Adapter—in Chromium75
No. 7671—Stayon Hoop Adapter—in Nobby Gold.....	.75

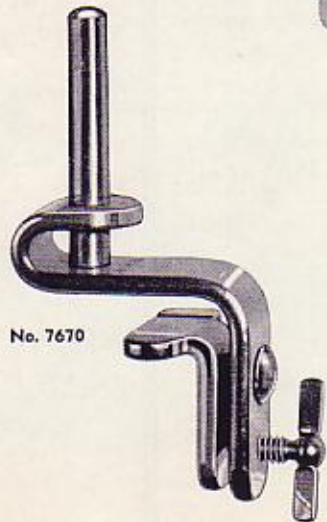
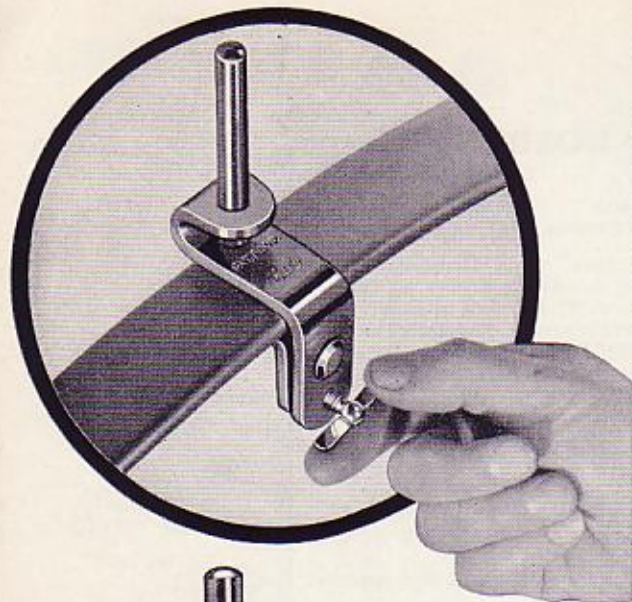

ZENJIAN CYMBALS—100% TURKISH TYPE

The Zenjian is the greatest cymbal value ever offered. Try one. A pleasant surprise awaits you. Note the rich, stinging, "hot", "whang" tone that rises and falls with lightning-like speed. Yes, these cymbals have every desired quality that modern music demands. The fundamental note varies in pitch with each cymbal, due to the variance in thickness. However, regardless of pitch the same fine quality of tone is ever present. Choosing the "best" is only a matter of preference in pitch.

Specify Thickness Desired . . . Thin--Medium Or Heavy

No. 7310—10"—Thin—High Pitch. Each\$ 6.50
No. 7311—11"—Thin—High Pitch. Each 7.00
No. 7312—12"—Thin—High Pitch. Each 8.00
No. 7313—13"—Thin—Medium or Heavy. Each 10.50
No. 7314—14"—Thin—Medium or Heavy. Each 12.50
No. 7315—15"—Thin—Medium or Heavy. Each 15.00
No. 7316—16"—Thin—Medium or Heavy. Each 17.00

DEEP CUP ZENJIAN CYMBAL

A special model particularly adapted for both sock cymbal and stick use. Light and extra thin with an extra deep cup for modern rhythm beats.

No. 7320—10"—Thin—High Pitch. Each\$8.00
------------------------------------	-------------

STAYON NON-SWING CYMBAL HOLDER

You are always assured of maximum cymbal tone when this holder is used. Cymbal "floats" on a self-aligning attachment that lifts off upright rod for speed in packing. No thumb screws to detach. Adjustable to height, distance and angle on the bass drum hoop. Made for both regular and deep cup cymbals.

For Single Cymbals

For Deep Cup Cymbals

No. 7518—Nickel\$2.00	No. 7506—Nickel\$2.50
No. 7520—Chromium 3.00	No. 7508—Chromium 3.75
No. 7519—Nobby Gold 3.00	No. 7507—Nobby Gold 3.75

EXTRA CYMBAL ATTACHMENTS ONLY

For Single Cymbals

For Deep Cup Cymbals

No. 7521—Nickel\$.70	No. 7496—Nickel\$1.20
No. 7523—Chromium 1.05	No. 7498—Chromium 1.80
No. 7522—Nobby Gold 1.05	No. 7497—Nobby Gold 1.80

GENUINE ZENJIAN CYMBAL

NOT
GUARANTEED
AGAINST
BREAKAGE

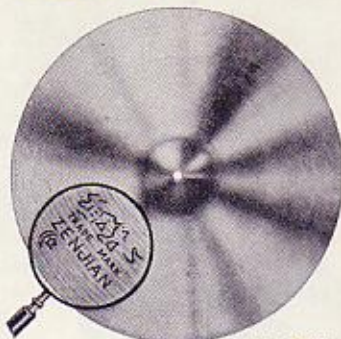

No. 7313



No. 7320



No. 7518



No. 7521



No. 7496



No. 7303

NOT
GUARANTEED
AGAINST
BREAKAGE



No. 7353



No. 7348



No. 7540

IMPORTED STANOPL CYMBALS

Stanople Cymbals are fine quality, imported Turkish-type cymbals with all the desired "sting" and vibratory qualities for the small or large orchestra, band and drum corps. More for the money than ever offered before in the low priced field. Order heavy cymbals for drum corps.

Specify Thickness Desired . . . Thin—Medium or Heavy

No. 7299—10" Deep Cup for sock and stick work. Each	\$ 7.00
No. 7300—10"—Thin—High Pitch. Each	5.50
No. 7301—11"—Thin—High Pitch. Each	6.00
No. 7302—12"—Thin, Medium or Heavy. Each	7.00
No. 7303—13"—Thin, Medium or Heavy. Each	9.00
No. 7304—14"—Thin, Medium or Heavy. Each	11.00
No. 7305—15"—Thin, Medium or Heavy. Each	13.50
No. 7306—16"—Thin, Medium or Heavy. Each	15.00

GENUINE CHEE FOO CHINESE CYMBALS

The Chee Foo Cymbals are acknowledged superior to all other Chinese Cymbals because of their crashy tone and durable qualities.

No. 7350—10" Each	\$ 2.00	No. 7355—15" Each	\$ 4.00
No. 7352—12" Each	2.50	No. 7358—18" Each	7.00
No. 7353—13" Each	3.00	No. 7360—20" Each	10.00

CHEE FOO CHINESE "WHANG" CYMBAL

An extra thin, small, and very high pitch Chinese Cymbal.

No. 7348—8" size only—Each	\$1.75
----------------------------	--------

NEW ERA STAYON CYMBAL HOLDER

The New Era Cymbal Holder has "everything"—rigidity, because of the "Stayon" clamp—height, distance and angle features because of the universal block for rod adjustment—and full ringing tone of the cymbal because of the self-aligning cymbal rests. A winner in every way.

For Two Cymbals		For One Cymbal	
No. 7540—Nickel	\$4.00	No. 7545—Nickel	\$2.50
No. 7542—Chromium	6.00	No. 7547—Chromium	3.75
No. 7541—Nobby Gold	6.00	No. 7546—Nobby Gold	3.75

Extra Arm and Block

No. 7550—Arm and Block Only (No Holder) Nickel	\$1.50
No. 7552—Arm and Block Only (No Holder) Chromium	2.25
No. 7551—Arm and Block Only (No Holder) Nobby Gold	2.25

AMERICAN NICKEL SILVER CYMBALS

More brilliant in tone than plain brass cymbals. Recommended for "sock" or regular pedal use. The finest nickel silver cymbals produced.

No. 7424—4"—Each	\$.85	No. 7431—11"—Each	\$2.50
No. 7428—8"—Each	1.20	No. 7432—12"—Each	3.00
No. 7430—10"—Each	2.00	No. 7433—13"—Each	3.50

AMERICAN BRASS CYMBALS

The most moderately priced brass cymbal on the market. Exceptional tone quality. Used for both regular and "sock" cymbal pedal playing.

No. 7437—7"—Each	\$.50	No. 7441—11"—Each	\$1.65
No. 7438—8"—Each75	No. 7442—12"—Each	1.90
No. 7440—10"—Each	1.15	No. 7443—13"—Each	2.40

No. 7450—10" Deep Cup for Sock and Stick work. Each \$1.25

"GIANT CUP" PLOP CYMBAL

The 10" cymbal with the 8" cup that produces the deepest, squashest, dirtiest "plop" tones ever heard. No longer necessary to "doctor" your cymbals for tone. Use these on sock pedals, on Non-Swing cymbal holders and inverted in pairs for stick work. Leedy made of finest quality American brass. Made in choice of three finishes.

No. 7454—10" Brass. Ea.	\$1.50	No. 7455—10" Nickel. Ea.	\$2.50
No. 7456—10" Chromium. Ea. \$3.50			

"SIZZLE" CYMBAL

A standard effect that "fits" in almost any modern rhythmic number.

No. 7452—12"—Each	\$2.50
-------------------------	--------

"STAYON" SUSPENSION CYMBAL HOLDERS

Cymbal swings freely on this holder, which is adjustable to any position.

With 1 Arm	With 2 Arms	Extra Arm and Clamp
No. 7585—N.P. ..\$1.50	No. 7580—N.P. ..\$2.30	No. 7590—N.P. ..\$.80
No. 7587—C.P. ... 2.25	No. 7582—C.P. ... 3.45	No. 7592—C.P. ... 1.20
No. 7586—N.G. ... 2.25	No. 7581—N.G. ... 3.45	No. 7591—N.G. ... 1.20

Prices Do Not Include Cymbals

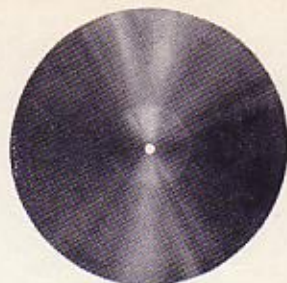

No. 7432



No. 7442



No. 7450



No. 7454



No. 7452



No. 7585

Use Crash Cymbal
Strap Hanger (No. 7600
on page 50) with
Nos. 7585 and No. 7580

CHOKE CYMBALS AND "STAYON" HOLDERS

Another modern cymbal "set-up". Consists of one 12" Chinese and one 8" American Brass Cymbal. Use them on either bass drum hoop or on trap table or console. Screw cymbals tight for "washboiler" effect—leave them loose for full, deep-toned "sizzle" effects.

Holder For Bass Drum Hoop

No. 7460—Nickel Plated\$1.25 No. 7462—Chromium Plated . \$1.75
No. 7461—Nobby Gold\$1.75

Holder For Trap Table Or Console

No. 7465—Nickel Plated\$1.00 No. 7467—Chromium Plated \$1.50
No. 7466—Nobby Gold\$1.50

Correct Cymbals For Choke Effect

No. 7352—12" Chinese Cymbal\$2.50 Extra
No. 7438—8" American Brass75 Extra

"STAYON" SPRING CYMBAL HOLDER

Full cymbal vibration is possible with this spring holder. Can be placed on the bass drum hoop and adjusted to proper angle so that cymbal will always swing level. Clamps firmly to the bass drum hoop and stays there because it has the new type Leedy "Stayon" clamp.

No. 7554—Nickel\$2.25 No. 7556—Chromium\$3.35
No. 7555—Nobby Gold\$3.35

"STAYON" GOOSE NECK CYMBAL HOLDER

Simple in design. This holder is now made with the Leedy "Stayon" clamp. Accommodates cymbals up to 10" diameter. Cymbal and Cymbal Strap Hanger are not included.

No. 7595—Nickel\$.60 No. 7597—Chromium\$.90
No. 7596—Nobby Gold\$.90

CRASH CYMBAL STRAP HANGER

This strap hanger is guaranteed to suspend your cymbal correctly. Consists of leather strap securely fastened to a metal disc which is covered with a thick felt washer. Use this with the Leedy "Stayon" Suspension Cymbal Holder and the Goose Neck Cymbal Holder.

No. 7600\$.25

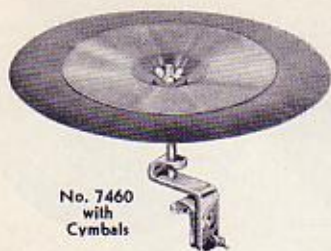

No. 7460
with
Cymbals



No. 7460

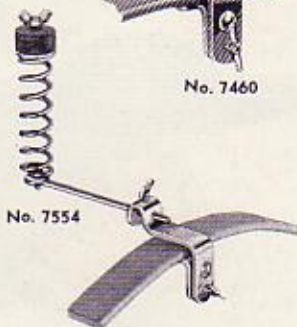

No. 7554

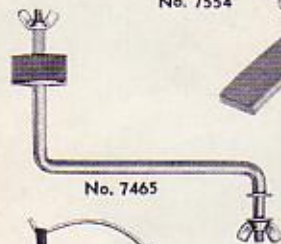

No. 7465



No. 7595



No. 7600

DEEP CUP CHOKE CYMBAL HOLDER

A brand new set up for stick work on brass deep cup choke cymbals. Made with Stayon bass drum hoop clamp. Thumb screw adjustment permits many effects, from sizzle to deepest hollow "squash" tones.

Holder for Bass Drum Hoop

No. 7457—Nickel Plated	\$.90
No. 7458—Chromium Plated	1.35
No. 7459—Nobby Gold	1.35

Correct Cymbals for Above Holder

Two No. 7450—10" Deep Cup Brass Cymbals at \$1.25 Each

DRUM STAND CYMBAL HOLDER

A neat, practical cymbal holder, especially adapted to fast work. Adjustable to height, distance from drum, and will swing to any point around the drum stand. Cymbal can be placed closer to snare drum than with any other type. Packs easily and quickly in drum case. Cymbals rock without swinging. Drum stand and cymbal not included.

No. 7500—Nickel.....	\$2.00	No. 7502—Chromium.....	3.00
No. 7501—Nobby Gold		3.00	

EGYPTIAN CYMBALS AND HOLDERS

Drummers should not be without these cymbals. They have that "stinging" tone that is ideal for "coloring". Set consists of one 3½" and one 3¼" cymbal, and holders. Each cymbal of different pitch. Best effect obtained by playing with the "tips" of the sticks in PP strains.

No. 7480—2 Cymbals and 2 Holders, Nickel	\$2.00
No. 7422—3¼" Cymbal only—Each85
No. 7423—3½" Cymbal only—Each85
No. 7485—Holders only—Per Pair, Nickel Plated80

FINGER CYMBALS

Made of American Brass. 2½" in diameter and possess a very high pitch tone. Equipped with quality web finger straps. Sold only in pairs.

No. 7490—Per Pair	\$.75
-------------------------	--------



No. 7457 with Cymbals

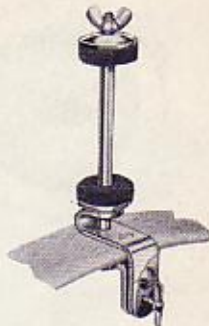

No. 7457



No. 7500



No. 7480



No. 7490

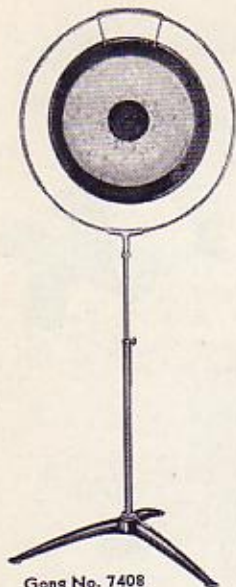

Gong No. 7408
Stand No. 7400

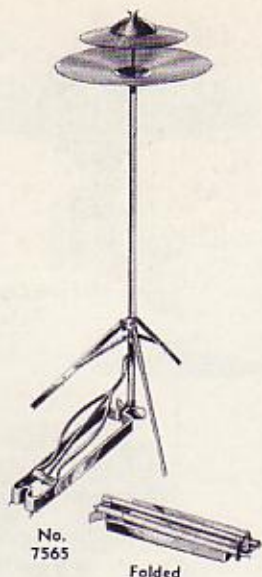

No.
7565

Folded

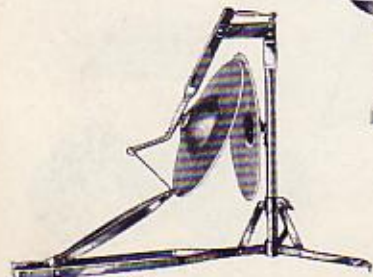

No. 7503

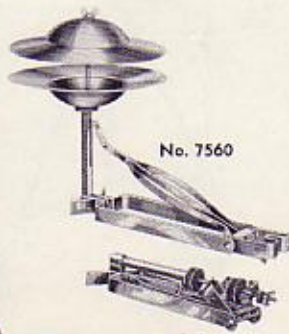

No. 7560

Folded

CHEE FOO CHINESE GONGS

These splendid gongs give forth a piercing crash obtainable on no other type when struck a hard, decisive blow. Unusually rich and sonorous in tone when struck lightly. Use Gong Stick No. 1640 shown on page 54.

No. 7404—14"—Each	\$7.00	No. 7408—18"—Each	\$10.00
No. 7406—16"—Each	8.50	No. 7410—20"—Each	12.00
No. 7413—23"—Each	\$18.00		

CHINESE GONG STAND

This stand has been greatly improved. It now has a heavier ring, telescopic posts and base. Will hold your gong steady. Finely finished.

No. 7400—Nickel	\$12.50	No. 7402—Chromium	\$17.50
No. 7401—Nobby Gold	\$17.50		

"HIGH HAT" SOCK CYMBAL PEDAL

Cymbals are 36 inches from the floor, where they are as handy for stick beats as they are for their intended "sock" work. "Sizzle" effects obtained by closing cymbals lightly. Many other desired effects are possible also. Pedal is light in weight and folds compactly for traveling. Sturdily constructed and well finished. Cymbals not included.

No. 7565—Nickel	\$ 8.50	No. 7567—Chromium	\$13.00
No. 7566—Nobby Gold	\$13.00		

LOW SOCK CYMBAL PEDAL

Identical to the "High Hat" Sock Cymbal Pedal shown above in mechanical construction and principle, but cymbals are 8½" from the floor. Pedal is light in weight, sturdily constructed, well finished, and folds compactly for traveling. Cymbals are not included.

No. 7560—Nickel	\$5.00	No. 7562—Chromium	\$8.00
No. 7561—Nobby Gold	\$8.00		

UPRIGHT SOCK CYMBAL PEDAL

A new type sock pedal. The cymbals are in a vertical position. The tone is more of a dead "squash" and without a "ring" as the cymbals come apart. Will not creep. Folds into small space. Cymbals are extra.

No. 7503—Nickel	\$ 7.50	No. 7505—Chromium	\$10.50
No. 7504—Nobby Gold	\$10.50		

RUMBLE TIPS—AN ORIGINAL LEEDY CREATION

Drummers proclaim them "knockouts." Rolls, rumbles and roars can be obtained with little effort with these unique accessories. By dragging them across the snare drum, bass drum, or Tom Tom head a roar-like rasp is produced which can be used with startling effect in such pieces as "Tiger Rag," etc. They bounce as they drag, making either open or closed rolls.

ALSO MAKE EXCELLENT TWO-WAY STICKS

Excellent for rapid passages in modern music where a quick change to felt sticks for soft cymbal or Tom Tom effects is not convenient.

No. 1604—Rumble Tips—Per Pair \$.50

"STAYON" STICK HOLDER

Keeps your drum sticks always in place, and the right stick always comes back in the right hand. Great for speed in getting over to your tympani, bells, etc. Leedy "STAYON" clamp. Wire is not plated.

No. 1606—Nickel \$.75 No. 1608—Chromium 1.00
 No. 1607—Nobby Gold 1.00

IMPROVED BASS DRUM TONE CONTROL

No. 7874 has a new "pressure adjustment" feature which permits any desired drum tone. Heavily plated 6" metal disc, and thick felt muffler pad. Stiffer spring prevents disc "jumping" away from head. You'll like this Tone Control best of all. Stayon clamp.

No. 7874—Nickel \$2.25
 No. 7875—Chromium 3.25
 No. 7876—Nobby Gold 3.25

New, stiffer spring prevents the pad from "jumping" away from head. Bigger 6" metal disc, heavily plated, and thick felt muffler pad permits better tone control. Disc swings in an arc from the drum hoop. Provided with the non-marring Stayon hoop clamp.

No. 7871—Nickel \$1.75
 No. 7872—Chromium 2.40
 No. 7873—Nobby Gold 2.40

SNARE DRUM TONE CONTROL

Fastens to the counter hoop. Will take the "ring" out of any snare drum. Consists of thick felt pad on steel spring with efficient hoop clamp. Swings in a 3½" arc from the drum hoop. Spring not plated.

No. 7635—Nickel \$1.00 No. 7637—Chromium \$1.50
 No. 7636—Nobby Gold \$1.50

Springs Not Plated



No. 1604



No. 1606



No. 7874



No. 7871

HICKORY STICKS

All Leedy models are obtainable in Hickory or Rosewood. Hickory models are made of selected, straight-grained, second-growth white stock. The Rosewood models are made of genuine British Honduras Rosewood selected from our xylophone bar stock. "H" denotes Hickory models; "R" denotes Rosewood models. Order by both letter and number.

H-10—17"	long, weight about 4 $\frac{1}{4}$ oz. per pair
H-11—14 $\frac{3}{4}$ "	long, weight about 3 $\frac{3}{4}$ oz. per pair
H-12—15 $\frac{1}{2}$ "	long, weight about 3 $\frac{3}{4}$ oz. per pair
H-13—15 $\frac{3}{4}$ "	long, weight about 3 $\frac{1}{2}$ oz. per pair
H-14—16"	long, weight about 3 $\frac{3}{4}$ oz. per pair
H-15—15 $\frac{1}{4}$ "	long, weight about 3 oz. per pair
H-16—15"	long, weight about 3 $\frac{3}{4}$ oz. per pair
H-18—15 $\frac{3}{4}$ "	long, weight about 5 oz. per pair
H-19—16"	long, weight about 4 $\frac{1}{4}$ oz. per pair
H-20—17"	long, weight about 5 $\frac{1}{2}$ oz. per pair
H-22—17"	long, weight about 5 $\frac{3}{4}$ oz. per pair
H-23—16"	long, weight about 3 $\frac{1}{2}$ oz. per pair

45c
PER PAIR

Please Order by Both Letter and Number

"R" models (ROSEWOOD) per pair \$.80
"RED END" Selected Models (see page 24) per pair75
Hickory Models in your choice of Duco colors, per pair	1.00

SPECIAL STICKS

Designed to obtain special effects, and especially useful where a quick change does not permit time to pick up another pair.

No. 1600—Felt Jazz Sticks. Medium texture solid felt balls	Per Pair \$1.25
No. 1601—Two-Way Sticks. Balls of solid medium felt	1.00
No. 1603—Felt shoulders and tips. For soft playing	1.50
No. 1605—"Rasp" Sticks. Notched hickory sticks for "rasping" against Cymbals, Wood Blocks, etc.	.50
No. 1640—Gong and Cymbal Stick. Brings out the best cymbal and gong tone. Solid medium texture felt. Each	1.00

SNAKEWOOD STICKS

Heavy in weight, close-grained, and have a glass-like finish. Owing to the fine, close grain these sticks can not be guaranteed against breakage

*S-30—17 $\frac{1}{4}$ " long—weight about 6 $\frac{3}{4}$ oz. per pair \$3.00
*S-35—16 $\frac{1}{2}$ " long—weight about 7 $\frac{1}{4}$ oz. per pair 3.00

PAGE 54

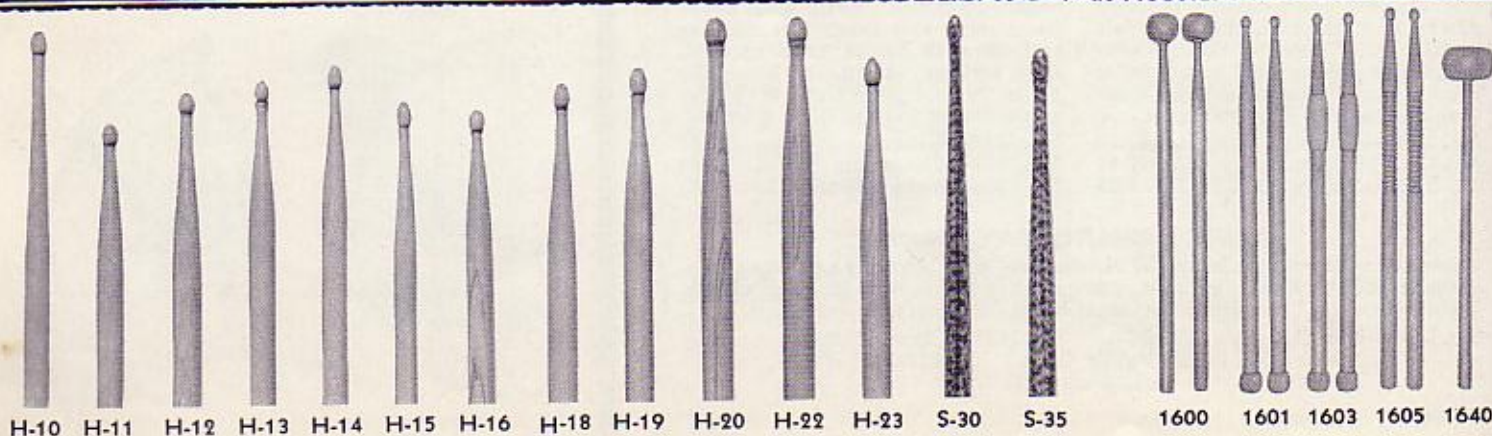

QUALITY BASS DRUM STICKS

Correct balance and weight, quality materials, careful workmanship, and the fine appearance of these sticks assure long service and satisfaction in every respect. All have Hickory handles unless described otherwise.

No. 1620—For "thud boom" tones—drum corps or band. Solid felt ball on each end	\$2.00
No. 1621—For "thud boom" tones—drum corps or band. Solid felt ball	1.75
No. 1622—For "long boom" tones — concert band. Lambs wool ball on each end	3.00
No. 1623—For "long boom" tones — concert band. Lambs wool ball	2.50
No. 1625—For "short boom" tones — band or drum corps. Felt-covered, resilient core balls. ...	2.00
No. 1624—For "short boom" tones — band or drum corps. Felt-covered, resilient core ball	1.75
No. 1626—For "long boom" tones — concert band. Gus Helmecke model. Extra large lambs wool balls. Extra length handle	3.50

No. 1627—For "long boom" tones — drum corps or parade band. Large lambs wool ball. Handle has leather thong	\$3.50
No. 1628—For "thud boom" tones with great volume — drum corps or band. Solid felt ball. Lambs wool grip and leather thong	2.50

SCOTCH BASS DRUM STICKS

No. 1633—3-ply felt balls, hickory handles with swivel spring and thongs. Per pair	\$4.50
No. 1634—3-ply felt balls, hickory handles with leather thongs only. Per pair	4.00
No. 1637—Lambs wool ball with felt core. Flexible Rattan handles and thongs. Per pair	5.00

TENOR DRUM STICKS

No. 1613—Lambs wool ball with felt core. Hickory handles with swivel and thongs. Per pair ...	\$4.50
No. 1614—Lambs wool ball with felt core. Hickory handles with leather thongs. Per pair	4.00
No. 1610—Solid felt balls. Hickory handles with leather thongs. Per pair	2.50

PAGE 55

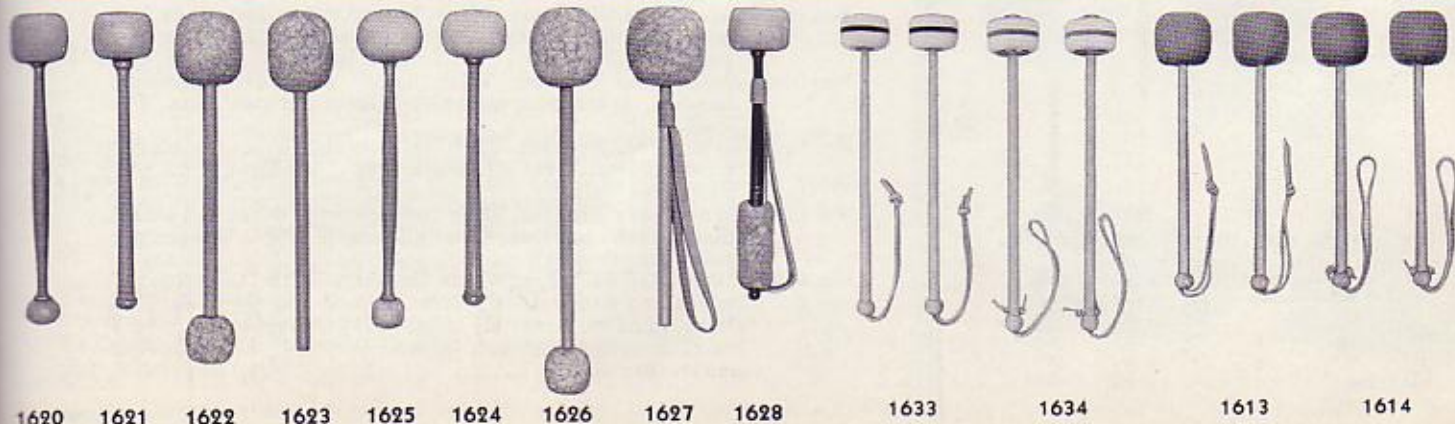

WITH "FIXED" (non-telescoping) WIRES

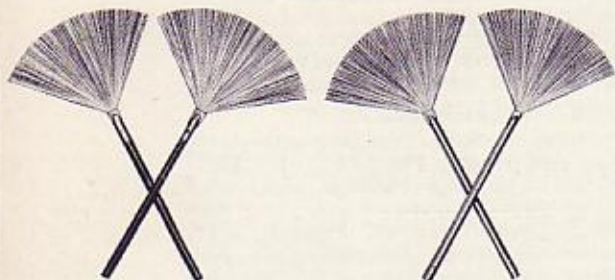

No. 1647

With Wood Handles

No. 1649

With Aluminum Handles

WITH TELESCOPING WIRES

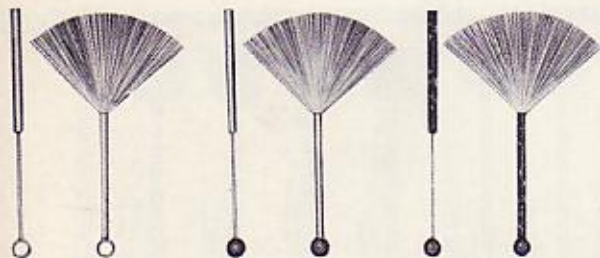

No. 1645

Aluminum
Handles

No. 1646

Nickel Plated
Brass Handles

No. 1648

Black and Gold
Pearl Handles

SYNCO-JAZZ BRUSHES

Wire brushes are here to stay. They are as much a standard part of the Drummer's "kit" as drum sticks. No modern Drummer would think of going on a job without them. They are the only thing that will fill the bill for real soft playing—the only rhythm effect that pleases leaders who "hold the drummer down". Use them on your cymbals, snare drum, bass drum and tom-toms just once and you'll never be without them again.

MADE IN TWO STYLES

To Meet the Requirements of Every Drummer

WITH "FIXED" WIRES

The New Model Leedy Synco-Jazz Brushes with the "fixed" wires are made to "stand the gaff". Each one has 200 of the finest quality tempered piano-steel wires securely acid-soldered into a brass ferrule which in turn is held firm and fast in either the wood or aluminum handles. Correctly designed for the best brush and "swish" effects.

WITH "TELESCOPING" WIRES

These models have been greatly improved. Made stronger than the former brushes: each one has 200 of the finest quality tempered piano-steel wires secured to the steel wire rod which pulls and pushes the brush in and out of the handles. Made in your choice of models as listed below.

FIVE INDIVIDUAL MODELS

- No. 1647—Synco-Jazz Brushes. With "fixed" wires and black lacquered wood handles. Over all length 15". Weight per pair 3 oz. Per Pair \$.60
- No. 1649—Synco-Jazz Brushes. With "fixed" wires and aluminum handles. Over all length 15". Weight per pair 3 oz. Per Pair75
- No. 1645—Synco-Jazz Brushes. With "telescoping" wires and aluminum handles. Over all length 12¾". Weight 2½ oz. per pair. Per Pair60
- No. 1646—Synco-Jazz Brushes. With "telescoping" wires and nickel plated brass handles. Over all length 12¾". Weight per pair 3 oz. Per Pair75
- No. 1648—"WHOOPEE" Synco-Jazz Brushes. With "telescoping" wires and Leedy "Full Dress" Black and Gold Mottled Pearl handles. Over all length 12½". Weight per pair 3 oz. The newest, hottest, jazziest Synco-Jazz Brush ever made. Per Pair 1.00

BASS DRUM CYMBAL HOLDER AND BEATER

Made of pressed steel nickel plated parts. Will not break. The only holder that is adjustable back and forth on the bass drum shell. Heavy felt-covered wood block rests on the shell. Will not mar the drum finish.

- No. 1855—Bass Drum Cymbal Holder\$1.75
 No. 1864—Beater. Wood Handle, 10" Wire Loop75

LAMBS WOOL HANDLE CYMBAL HOLDERS

An improved type made with a spring that permits full, free cymbal vibration. Also acts as a snubber to absorb the shock of the blows. Handles covered with lambs wool, which prevents blistered hands.

- No. 1861—Lambs Wool Handle Holders, Per Pair\$2.50

WOOD HANDLE CYMBAL HOLDERS

Widely used, and practical in every respect, but without the fine features of No. 1861. Have adjustable straps, and handles shaped to fit the hands.

- No. 1860—Wood Handle Cymbal Holders, Per Pair\$1.50

CYMBAL STRAPS AND PADS

Heavier horsehide than most makes, and therefore stronger. Permit full cymbal tone and protect the hands and knuckles from bruising. Practical, low priced, and widely used with very satisfactory results.

- No. 1851—Pads, Per Pair\$1.00
 No. 1850—Straps, Per Pair50

"TWO-WAY" PRACTICE PAD

The "Two-Way" Practice Pad is ideal for student and professional. Has two playing surfaces, both inclined at the proper angle. The rubber side is used for noiseless practice and the fibre side for loud practice. Will not "creep" under strong beating. Guaranteed sturdy and satisfactory.

- No. 1755—"Two-Way" Practice Pad\$2.75

PLAIN PRACTICE PAD

This practice pad consists of 4" circle of 3/16" rubber cemented on a rock maple base. Produces a rebound of the sticks very similar to that of a drum. Pad is now inclined to the proper playing angle.

- No. 1760—Plain Practice Pad\$1.00

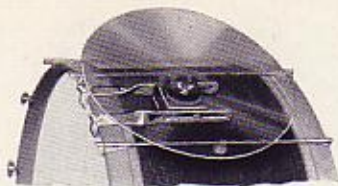

No. 1855



No. 1850



No. 1861



No. 1851



No. 1860



No. 1760



Fibre Side



Rubber Side

No. 1755



No. 1867

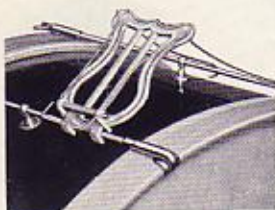

No. 1868



No. 1885



No. 1910



No. 1991

THE ORIGINAL LEEDY RAIN COVER (Patented)

This Rain Cover is thoroughly waterproof and very light. The adjustable metal band that extends around the inside of the counter hoop and holds the cover tight against the batter head makes it practically impossible for air to get between the head and the cover—therefore tone and playing qualities are not seriously impaired. Will save its cost in drum heads many times over. Simply fold the cover and put it in your pocket when not needed, and let the metal band stay on the drum.

Please State Both Shell and Over-All Size of Drum When Ordering

No. 1910—Rain Cover (With Metal Head Band)	\$4.00
No. 1911—Rain Cover (Without Metal Band)	3.00

PARADE MUSIC HOLDERS

Placed inside and buttoned under coat. Clamp inserted in tubing on breast plate. Ideal for parade work. Light and convenient in every way.

No. 1867—Snare Drummer's Music Holder, Each \$2.00

Made of aluminum, light in weight and very durable, this music holder fastens on bass drum rods. Holds music securely. Easily attached.

No. 1868—Bass Drum Music Holder \$2.00

PARADE LEG REST

This Leg Rest may be attached to the shell of any street drum. The wide curved metal "cradle" is formed to fit the leg just above the knee. Prevents drum from bouncing out of place when on the march. Try one for real drum carrying comfort. Folds up against shell when not in use.

No. 1885—Parade Leg Rest, Nickel	\$2.00
No. 1869—Parade Leg Rest, Chromium	3.00

DETACHABLE PARADE LEG REST

More fully adjustable than any other parade leg rest on the market because it holds the drum to the leg at any desired angle. Can be attached to, and removed from, the drum in just a few seconds without the use of any tools. Cannot mar the drum shell and is comfortable on parade.

No. 1991—Detachable Parade Leg Rest. Nickel	\$2.50
No. 1992—Detachable Parade Leg Rest. Chromium	3.50

WEB SNARE DRUM SLING

Made of stout 2" webbing strongly sewn, and is adjustable for length. Has the new strong, heavy-duty swivel snap and the new hook arrangement which permits the entire sling to lie flat against the body. Nickel plated buckle. Made in choice of khaki or white.

No. 1879—Web Snare Drum Sling—Khaki	\$1.20
No. 1880—Web Snare Drum Sling—White	1.20

WEB BASS DRUM SLING

Strongly made of heavy 2" webbing. Crosses over the back and is adjustable. Center hook fastens to bass drum eye in the middle of the shell and end hooks fasten to opposite ends of a bass drum rod. Metal parts heavily nickelled. Made in your choice of khaki or white.

No. 1900—Web Bass Drum Sling—Khaki	\$1.50
No. 1901—Web Bass Drum Sling—White	1.50

EXTRA HEAVY WEB BASS DRUM SLING

Distributes the weight of the drum over the back and shoulders. Made of extra heavy webbing with adjustable metal grip fasteners and the new heavy-duty swivel snaps. Comfortable for use on even the longest parade, and worth the small price difference. Choice of khaki or white webbing.

No. 1905—Extra Heavy Web Bass Drum Sling—Khaki	\$2.25
No. 1906—Extra Heavy Web Bass Drum Sling—White	2.25

SLING and BELT ACCESSORIES

No. 1886—Belt Eye for Metal Hoop—Nickel	\$.25
No. 1888—Belt Eye for Metal Hoop—Chromium35
No. 1889—Belt Eye for Wood Hoop—Nickel50
No. 1891—Belt Eye for Wood Hoop—Chromium75
No. 1894—New Type Heavy Belt Swivel Snap Hook—Nickel50
No. 1897—Replacement Hook for No's. 1905 and 189850
No. 1898—Loop Strap and Swivel Snap Hook for Sam Browne Belt	1.00



No. 1879



No. 1898



No. 1894



No. 1897



No. 1886



No. 1889

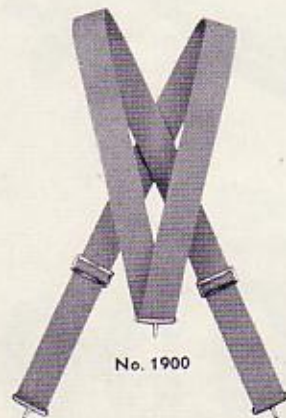

No. 1900



No. 1905

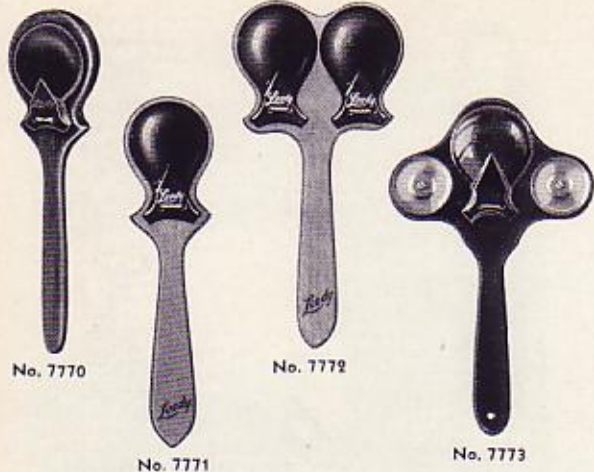

No. 7770

No. 7772

No. 7771

No. 7773



No. 7775



No. 7765



No. 7760

No. 7761

No. 7762

No. 7763

No. 7764

REALTONE CASTANETS ON HANDLES

Castanets are an important Drummer's instrument. The tone must be right. Leedy models are typically Spanish in character, giving that penetrating tone that livens up any number in which they are used. No. 7770 has an exceptionally thick rosewood sounding board and handle which further improves the tone. Nos. 7771 and 7772 have rock maple sounding boards, and No. 7773 has combination castanets and jingles for combined tambo and castanet effects, requiring only one hand for playing.

No. 7770—Each	\$2.00	No. 7772—Each	\$1.75
No. 7771—Each	1.00	No. 7773—Each	1.75

REALTONE CASTANETS

Made of an unbreakable composition and moulded to shape in gigantic power presses under hundreds of tons pressure. They are of the proper weight and shape to produce the true Spanish tone. A set consists of two pair—one pair for each hand. Look for the Leedy name.

No. 7775—Per Pair	\$.60
-------------------------	--------

SOLID WOOD SHELL TAMBOURINES

All Leedy Tambourines are of extra thick wood shell construction with a glossy natural walnut finish. Jingles are our own make best quality nickel silver and will not fall out. Best Hardwhite calf heads. Built to give real service. These features, with their fine tone, have made them the choice of discriminating drummers and dancers everywhere. No. 7764 is made especially for school work.

No. 7760—10" Diameter—12 pair Jingles	\$3.50
No. 7761—10" Diameter— 9 pair Jingles	2.50
No. 7762— 8" Diameter— 7 pair Jingles	2.00
No. 7763— 7" Diameter— 6 pair Jingles	1.50
No. 7764— 7" Diameter— 6 pair Jingles—Red Shell ..	1.00

"STAYON" TAMBOURINE HOLDER

Gives an excellent "sizzle" effect because tambourine vibrates with every pedal beat. Very effective in "hot" choruses. Can be lifted off post very quickly. The clamp remains in place on the tambourine.

No. 7765—Nickel	\$.75	No. 7767—Chromium	\$1.25
No. 7766—Nobby Gold	\$1.25		

REALTONE TRIANGLES

Made of the finest quality steel, they have a clear, rich, brilliant and distinct tone. Made in three sizes as listed below.

No. 7615—6" Size. Nickel \$.75 No. 7618—8" Size. Nickel \$1.00
 No. 7616—6" Size. Chromium 1.25 No. 7619—8" Size. Chromium 1.60
 No. 7620—10" Size. Nickel \$1.25
 No. 7621—10" Size. Chromium 2.00

It is Not Practical To Finish Triangles In Nobby Gold

TRIANGLE HOLDER

Clamps securely to the bass drum hoop without marring the hoop's finish.

No. 7622—Nickel \$.60 No. 7623—Chromium \$.90
 No. 7624—Nobby Gold \$.90

ROSEWOOD CLAVES

These imported rosewood claves are needed for the effects necessary in the Spanish rumbas, and boleros as well as in many of the novelty numbers that are characteristically Spanish. These imported rosewood claves are "mated" pairs—one having a higher tone than the other.

No. 7778—Rosewood Claves, per pair \$1.25

REALTONE MARACAS

The ball is 4" in diameter, of moulded Bakelite and partly filled with shot, which gives forth the same tone and volume as the Spanish product. Indispensable in "rumba", tango and most Spanish dance and descriptive numbers. More durable—louder—flashier—and cost less than the imported vegetable products.

No. 7777—Leedy Maracas, Per Pair \$3.00

MIDGET SLAP STICKS

Every drummer has use for these. Short length and light weight. Easy to manipulate. Usually played in pairs. 15" long, and 1½" wide.

No. 7605—Per Pair \$2.00
 No. 7606—Each 1.00

REGULAR SLAP STICKS

Longer and wider than the Midget sticks. Made of rock maple. Very loud. Perfect whip imitation. 19" long, 2" wide. Strong and serviceable.

No. 7610—Each \$1.25

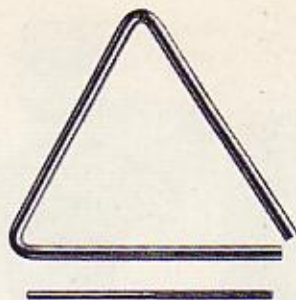

No. 7618

No. 7622



No. 7777

No. 7778

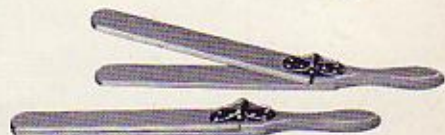

No. 7605



No. 7610



No. 7200

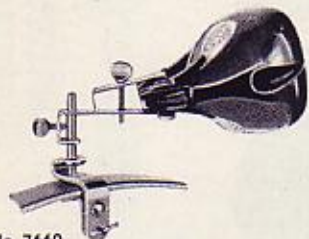

No. 7660



No. 7640



No. 7641



No. 7642



No. 7643



No. 7644

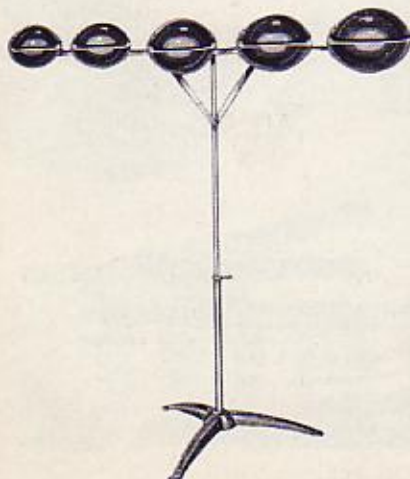

No. 7655

KOREAN TEMPLE BLOCKS

These Temple Blocks have that weird, deep, and mysterious tone so desirable in modern rhythmic numbers. They are beautifully finished in glossy black, red and gold lacquer. They sound best when played upon with half-hard rubber mallets (Leedy No. 1704). These Temple Blocks are tuned to correct intervals and carefully refinished in our own factory. This insures better tone, finer appearance and greater satisfaction.

No. 7640—4 $\frac{1}{2}$ "	\$2.50
No. 7641—5"	3.50
No. 7642—5 $\frac{1}{2}$ "	4.00
No. 7643—6"	5.00
No. 7644—6 $\frac{1}{2}$ "	6.00
No. 7650—Complete Set of 5 Temple Blocks	\$18.00

Temple Blocks finished in a combination of any three lacquer colors of your choice, per set\$4.00 Extra

TEMPLE BLOCK HOLDER (Block Clamp Only)

For Trap Console—Trap Table—Trap Rail—Or Hoop Adapter

This holder fits any upright post of the Trap Table, Trap Rail, or Trap Console. Fits any size Temple Block up to 8". Constructed of pressed steel parts, strong, light in weight, carefully made and finely finished.

No. 7200—Nickel	\$.75	No. 7202—Chromium	\$1.25
No. 7201—Nobby Gold	\$1.25		

BASS DRUM TEMPLE BLOCK HOLDER

This holder is especially designed for use on bass drum hoops, when only one or two Temple Blocks are needed. Strong, rigid, and adjustable to position. Has the new "STAYON" clamp and will stay on.

No. 7660—Nickel	\$1.25	No. 7662—Chromium	\$1.90
No. 7661—Nobby Gold	\$1.90		

TEMPLE BLOCK STAND

Temple Blocks Not Included

Stand weighs only 10 lbs. and is adjustable to height. Well built, solid, and sturdy. Blocks easily detachable. However, as rail comes apart from upright rod, the blocks and rail may be carried as a unit.

No. 7655—Nickel	\$10.00	No. 7657—Chromium	\$15.00
No. 7656—Nobby Gold	\$15.00		

Improved

THE WORLD'S FINEST

Leedy

TUNABLE TOM TOMS—IN CHOICE OF "FULL DRESS" FINISHES

WITH PIGSKIN HEADS FOR BETTER TONE

Now it's your turn to laugh at Old Man Weather! For years he has been playing tricks on you—tightening and loosening the heads of your Tom Toms just about as he pleased while you have been helpless to do anything about it. But with these Leedy "FULL DRESS" Tunable Tom Toms you can beat the old fellow at his own game. A few twists of the wrist and the heads are tensioned exactly as you want them with that full, deep, heavy, true Tom Tom tone.

We can unreservedly guarantee Leedy Tunable Tom Toms to have better tone than imported Chinese Tom Toms, and to be more durable in every respect due to their stronger and better shell construction. They are unsurpassed!



16" x 16"

With Nickel Plated Rods

- No. 8007—With Choice of "Full Dress" Finishes \$32.50
- No. 8008—With Choice of Duco colors 23.00
- With Chromium Plated Rods \$3.00 Extra
- With Nobby Gold Rods 3.00 Extra
- With Diamond Decorations (see p. 10) 6.50 Extra

14" x 12"

With Nickel Plated Rods

- No. 8027—With Choice of "Full Dress" Finishes \$27.50
- No. 8028—With Choice of Duco colors 18.00
- With Chromium Plated Rods \$3.00 Extra
- With Nobby Gold Rods 3.00 Extra
- With Diamond Decorations (see p. 10) 6.50 Extra

13" x 9"

With Nickel Plated Rods

- No. 8047—With Choice of "Full Dress" Finishes \$18.00
- No. 8048—With Choice of Duco colors 12.00
- With Chromium Plated Rods \$3.00 Extra
- With Nobby Gold Rods 3.00 Extra
- With Diamond Decorations (see p. 10) 6.50 Extra

10" x 4"—Regulation Size

Not Illustrated Not Tunable

- No. 8067—With Choice of "Full Dress" Finishes \$8.00
- No. 8068—With Choice of Duco colors 6.00
- With Diamond Decorations (see p. 10) 2.00 Extra

FOLDING ADJUSTABLE TOM TOM STANDS

Fits all "Full Dress" Tom Toms except the 10" x 4" size. Simply turn thumb screw for height adjustment. Can also be used on Chinese models. Folds compactly.

- No. 7750—Nickel \$4.00
- No. 7752—Chromium 6.00
- No. 7751—Nobby Gold 6.00

GENUINE CHEE FOO CHINESE WOOD BLOCKS

Chee Foo Wood Blocks are noted for their superior tone. Made in three sizes; each block made in one piece from Chinese Redwood and drilled at both ends. Owing to our climatic conditions it is impossible to guarantee the blocks against checking or cracking. However, we always make the most careful selections to assure you of the best blocks obtainable.

No. 7682—8" long	\$2.00
No. 7681—7 $\frac{1}{4}$ " long	1.30
No. 7680—7" long75

"STAYON" REGULAR WOOD BLOCK HOLDER

Wood Block Not Included

Adjustable to all size Chinese wood blocks, and can be used on either the right or left side of the bass drum. Has the new non-marring Leedy "Stayon" clamp which will hold in the position you want it.

No. 7700—Nickel	\$.60
No. 7702—Chromium90
No. 7701—Nobby Gold90

"STAYON" SUSPENSION WOOD BLOCK HOLDER

Wood Block Not Included

The best ever. The block is suspended in mid air on heavy cords permitting full tone of the block without the usual disturbing metallic or bass drum "sub-sounds". Made with the new Leedy "Stayon" clamp.

No. 7690—Nickel	\$1.75
No. 7692—Chromium	2.50
No. 7691—Nobby Gold	2.50

ROUND TOP WOOD BLOCK

Block is laced on thick felt which is attached to the bass drum hoop by strong cords. Has a deep, rich tone. Not necessary to drum on the edge of the slot; the best tone is on the top of the rounded surface. A wonder for wear, tone, and all around playing satisfaction.

No. 7685—Complete as illustrated	\$1.50
--	--------



No. 7682



No. 7681



No. 7680

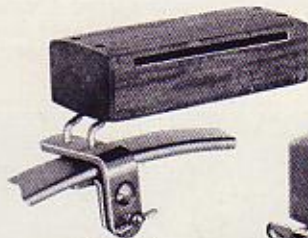

No. 7700

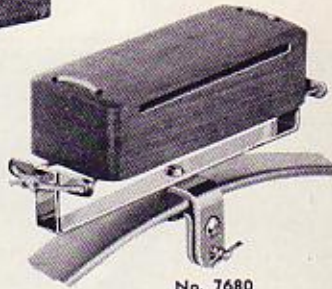

No. 7680



No. 7685

GENUINE CHEE FOO CHINESE TOM TOMS

Every modern Drummer now owns two or more Tom Toms. They are as important as cymbals. These are the genuine Chee Foo models: real pigskin, hand decorated heads, hand made tacks and brightly lacquered shells. They are noted for their rich tonal qualities and appearance.

No. 7715—10"x4"\$3.30 No. 7716—12"x5½"\$6.00
 No. 7717—15"x6½"\$10.00

ADVANCE "STAYON" TOM TOM HOLDER

The strongest and most efficient Tom Tom Holder made. A strong, fitted plate screws fast to the tom tom shell, and holder is adjustable to height and angle. Clamps securely to drum hoop with the new "Stayon" clamp.

No. 7720—Nickel\$2.00 No. 7722—Chromium\$3.00
 No. 7721—Nobby Gold\$3.00

REGULAR "STAYON" TOM TOM HOLDER

Note the improved cradle on this holder. Tom Tom can be adjusted to height and angle. Clamps securely with the new "Stayon" clamp.

No. 7725—Nickel\$.90 No. 7727—Chromium\$1.35
 No. 7726—Nobby Gold\$1.35

GIANT CHEE FOO CHINESE TOM TOMS

Large Tom Toms play an important part in almost every modern tune. These have that wonderful, deep, resonant tone, and are better made than most imported Chinese Toms. Heads are durable pigskin fastened with strong, ornate hand-made tacks to the wood shells, which are lacquered a glossy rich black. Made in three sizes.

No. 7730—Size 16"x16"\$21.00 No. 7731—Size 12"x14"\$16.00
 No. 7732—Size 9"x13"\$12.00

ADJUSTABLE TOM TOM STANDS

For Tunable "Full Dress" and Giant Tom Toms

A fine stand that will prove a winner where hard use and wear are the test. Fully adjustable to size and height.

No. 7750—Nickel\$4.00 No. 7752—Chromium\$6.00
 No. 7751—Nobby Gold\$6.00

Owing to the peculiarities of Chinese materials and methods of manufacture, we can not guarantee Tom Toms, Temple Blocks, etc. to withstand our climatic conditions. Prices on this merchandise are also subject to change without notice due to varying market conditions that exist.



Nos. 7717, 7716 and 7715

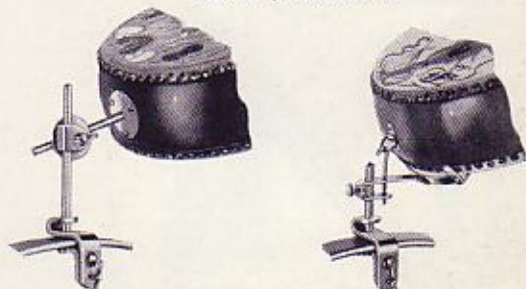

No. 7720

No. 7725



Nos. 7730, 7731 7732 on Stand No. 7750



No. 7750 Folded



No. 7785



No. 7790

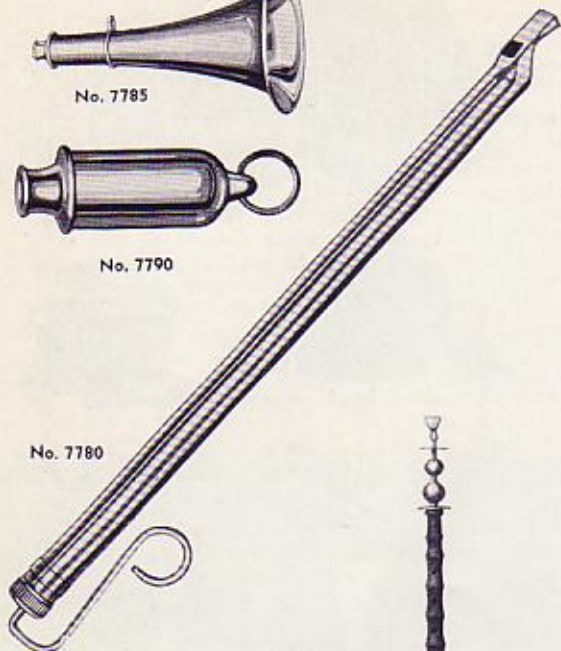

No. 7780

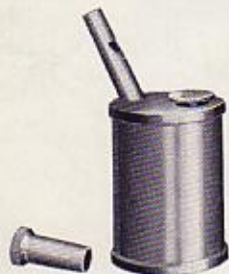

No. 7902



No. 7755

CYCLONE WHISTLES

A really good cyclone whistle must operate smoothly and without flaw under the slightest breath or vigorous blowing. The two cyclone whistles shown here operate in just that way. The megaphone type has a generous $3\frac{7}{8}$ " bell and is capable of the greatest possible volume. The two whistles are identical in internal mechanism, design and quality, and both will give genuine satisfaction and long service. Both are heavily nickel plated and will retain their appearance for an indefinite time. You should have one of these whistles among your effects.

No. 7785—Megaphone Cyclone Whistle	\$2.50
No. 7790—Regular Cyclone Whistle	1.00

SONG WHISTLE

The Leedy Song Whistle is a legitimate musical instrument and one that is very easy to master. Merely pull the slide out for the low note and push the slide in for the highest note. A tremelo is produced by slightly wavering the hand holding the slide. Anyone can play a tune on this whistle after a few minutes practice. Extensively used over the radio, on phonograph recordings and on the stage. The tone is clear, rich, mellow and flute-like, and many highly pleasing effects can be obtained in addition to straight playing. Made of brass, heavily nickel plated, and the plunger has a self-lubricating packing which will wear indefinitely. A strong, serviceable little musical instrument, and a mighty handy little accessory for the drummer's kit.

No. 7780—Song Whistle	\$1.50
-----------------------------	--------

BIRD WHISTLE

A correctly voiced, water-carrying bird imitation that will not fail you when you need it most. Short spout will not break off. Imitates almost any type of bird. When tipped away from mouth a straight whistle without a warble is obtained. Heavily nickel plated, and will not leak.

No. 7902	\$1.75
----------------	--------

GENUINE CHEE FOO CHINESE MUsETTES

Musettes are used a great deal in jazz orchestras and Oriental bands. This is the genuine Chinese model and has that weird Oriental tone. A true novelty wherever heard. Great for specialty numbers.

*No. 7755—18" long	\$1.25
*No. 7758—Reeds, each04

GENUINE CHEE FOO CHINESE TOM TOMS

Every modern Drummer now owns two or more Tom Toms. They are as important as cymbals. These are the genuine Chee Foo models: real pigskin, hand decorated heads, hand made tacks and brightly lacquered shells. They are noted for their rich tonal qualities and appearance.

No. 7715—10"x4"\$3.30 No. 7716—12"x5½"\$6.00
 No. 7717—15"x6½"\$10.00

ADVANCE "STAYON" TOM TOM HOLDER

The strongest and most efficient Tom Tom Holder made. A strong, fitted plate screws fast to the tom tom shell, and holder is adjustable to height and angle. Clamps securely to drum hoop with the new "Stayon" clamp.

No. 7720—Nickel\$2.00 No. 7722—Chromium\$3.00
 No. 7721—Nobby Gold\$3.00

REGULAR "STAYON" TOM TOM HOLDER

Note the improved cradle on this holder. Tom Tom can be adjusted to height and angle. Clamps securely with the new "Stayon" clamp.

No. 7725—Nickel\$.90 No. 7727—Chromium\$1.35
 No. 7726—Nobby Gold\$1.35

GIANT CHEE FOO CHINESE TOM TOMS

Large Tom Toms play an important part in almost every modern tune. These have that wonderful, deep, resonant tone, and are better made than most imported Chinese Toms. Heads are durable pigskin fastened with strong, ornate hand-made tacks to the wood shells, which are lacquered a glossy rich black. Made in three sizes.

No. 7730—Size 16"x16"\$21.00 No. 7731—Size 12"x14"\$16.00
 No. 7732—Size 9"x13"\$12.00

ADJUSTABLE TOM TOM STANDS

For Tunable "Full Dress" and Giant Tom Toms

A fine stand that will prove a winner where hard use and wear are the test. Fully adjustable to size and height.

No. 7750—Nickel\$4.00 No. 7752—Chromium\$6.00
 No. 7751—Nobby Gold\$6.00

Owing to the peculiarities of Chinese materials and methods of manufacture, we can not guarantee Tom Toms, Temple Blocks, etc. to withstand our climatic conditions. Prices on this merchandise are also subject to change without notice due to varying market conditions that exist.



Nos. 7717, 7716 and 7715

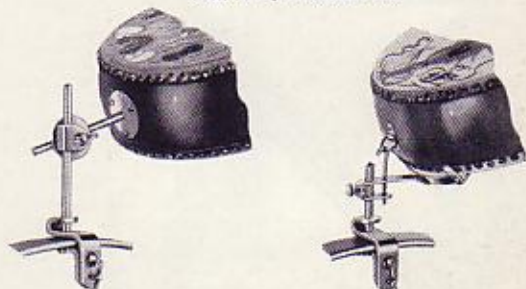

No. 7720

No. 7725



Nos. 7730, 7731 7732 on Stand No. 7750



No. 7750 Folded

SLEIGH BELLS ON DISC AND STRAP

Sleigh bells will always be in demand. Cheap bells ruin the effect. These are high grade cast bell metal, with quality leather straps on the No. 7820, and a detachable handle with the bells mounted on a fibre disc on the No. 7825. This system of bell mounting permits the drummer to play in rhythm. You will find plenty of use for whichever model you choose. Both are strongly made and will give a lifetime of satisfactory service.

No. 7820—11 Bells on Strap	\$2.50
No. 7825—12 Bells on Disc	3.50

FOUR TONGUE WOOD RATTLE

Due to its four tongues striking alternately, a real close roll is produced. Sturdily constructed of rock maple, with a pressed steel casing. Very durable. Clamps securely to bass drum without marring the hoop.

No. 7835	\$2.50
----------------	--------

COW BELLS AND HOLDER WITH "STAYON" CLAMP

Tuned to low C, G, E, and C, cow bell sets can be used to advantage in many places. That low, pleasing "hollow" tone so desired in modern numbers is obtained by using felt sticks shown on page 54, or rubber xylophone mallets. Individual bracket—clamps hold the cow bells to the post type holder which fastens to the bass drum hoop with a "Stayon" clamp. Short post holder accommodates two cow bells. Convenient.

No. 7904—4 Cow Bells and Nickel Plated Holder	\$5.00
No. 7906—4 Cow Bells and Chromium Plated Holder ..	5.50
No. 7905—4 Cow Bells and Nobby Gold Holder	5.50

Long Holder With Four Bell Clamps

No. 7800—Nickel Plated	\$1.00
No. 7802—Chromium Plated ..	1.50
No. 7801—Nobby Gold	1.50

Cow Bell Clamps Only

No. 7220—Nickel Plated	\$.15
No. 7222—Chromium Plated ..	.25
No. 7221—Nobby Gold25

Short Holder With One Bell Clamp

No. 7805—Nickel Plated	\$.65
No. 7807—Chromium Plated ..	1.00
No. 7806—Nobby Gold	1.00

Cow Bells Only

No. 7795—3½" —C—	\$.75
No. 7796—4¼" —E—90
No. 7797—5" —G—	1.05
No. 7798—6½" —C—	1.30



No. 7825



No. 7820



No. 7835



No. 7220

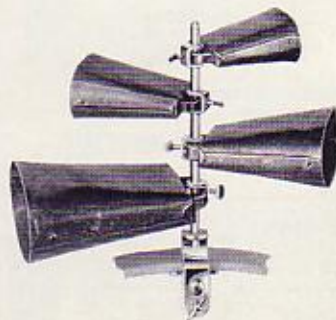

No. 7904



No. 7805

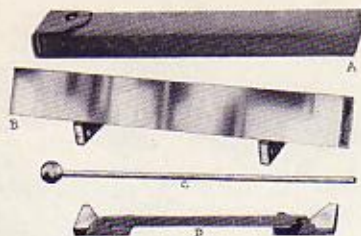

No. 7855

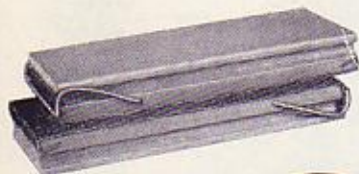

No. 7845

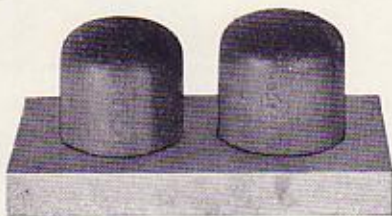

No. 7850

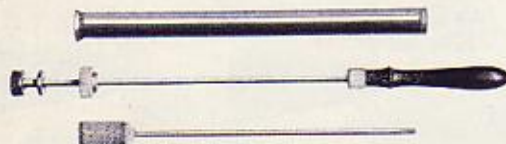

No. 7860

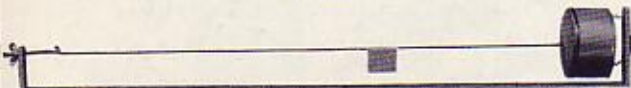

No. 7840

REALTONE ANVIL

A poor anvil imitation is worse than no anvil imitation at all. The Leedy Realtone Anvil will give the desired realistic effect that is so necessary at times. Tone is ample for the largest brass band and the two-tone effect is obtained by striking on the side and on the edge. Small and compact, the anvil packed neatly into its waterproof case and weighs only $3\frac{1}{4}$ lbs.

A—Packed in Waterproof Case
B—Set Up Ready for Use
C—Metal Anvil Beater
D—Anvil Rack Folded to Insert in Anvil

No. 7855—Realtone Anvil, complete\$6.00

DETACHABLE SANDPAPER BLOCKS

When sandpaper is worn out, the old can be removed and new put on in only a few seconds. No tacks or hammer are necessary. The best made. Ample in size and will last a lifetime.

No. 7845—Per Pair\$1.25

REALISTIC HORSE HOOFS

Made of finest rock maple, and designed to give the characteristic tone. Shaped to fit the hands. Ideal for imitating hoof beats on the pavement and for cocoanut dances. Slab is of durable composition.

No. 7850—Complete Outfit\$2.00

SURE-FIRE POP GUN

No other pop gun imitation can compare with this one for the desired effect and positive action. This one is reliable and always ready for use. Sure-firing and self-loading. The finest possible to make.

No. 7860—Complete, as shown\$4.00

ONE HAND DOG BARK

Fine characteristic dog bark tone which is operated with one hand and folds into a small space. Pitch is controlled by a tension screw on one end. Always pull *from* the tension screw end. Tone travels down the string. Sweeping strokes and short jerks produce the wildest noises. A splendid imitation, a fine trap and adapted to all dog bark effects.

No. 7840—Complete, as shown\$2.50

REALTONE WOOD WHISTLES

Unusual care, and quality materials are used in making Leedy Realtone Wood Whistles. Each is guaranteed to be correctly voiced, and to meet every requirement for the use it is intended. Every drummer doing radio, vaudeville or specialty work will have need for one, or several, of the whistles described below. Full satisfaction is assured.

- *No. 7881—Cuckoo Call. Finest possible tone, and has a plunger for tuning to the desired key. Substantially made \$2.25
- *No. 7882—Two-tone Locomotive Whistle. Realistic tone of the proper depth with plenty of volume. Strongly made 2.00
- *No. 7883—Three-tone Locomotive or Steamboat Whistle. Characteristically toned with ample volume. Durably made 3.60
- *No. 7884—Large deep-toned Ocean Steamboat Whistle. Larger, fuller and more sonorous toned than the No. 7883 4.50

ALL METAL BOAT AND LOCOMOTIVE WHISTLE

This is an exceptionally strong and well made all metal boat and locomotive whistle. Made of brass tubing and heavily nickel plated. Only 7¼" long, true in tone, and easy to blow. Will give a lifetime of service.

- *No. 7880—All Metal Boat and Locomotive Whistle \$3.50

EXTRA THICK REALTONE BELL PLATE

Locomotive and Fire Engine Bell Effect

Has a richer and more realistic bell tone than most plates because it is thicker. Made of ¼" thick finest quality saw steel. Real imitation of locomotive bell, and the correct imitation of patrol and fire bells when played single stroke roll fashion with butt ends of drum sticks or bell hammers. Costs a bit more than some other plates, but well worth the slight difference. Rawhide mallet is included.

- *No. 7865—Bell Plate Complete with Mallet \$4.00

REALTONE LOCOMOTIVE IMITATION

The hollow sounding board is made to give an extremely deep locomotive imitation—not the thin, tinny tone so commonly heard. Wood sound box has sheet steel covering on which are 160 projecting "bumps".

- *No. 7870—Realtone Locomotive Imitation Complete with Brush \$3.50

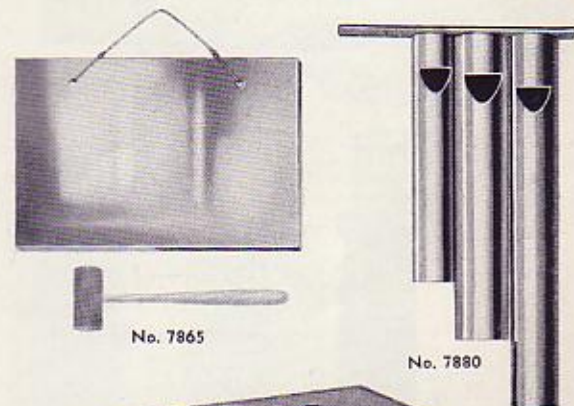
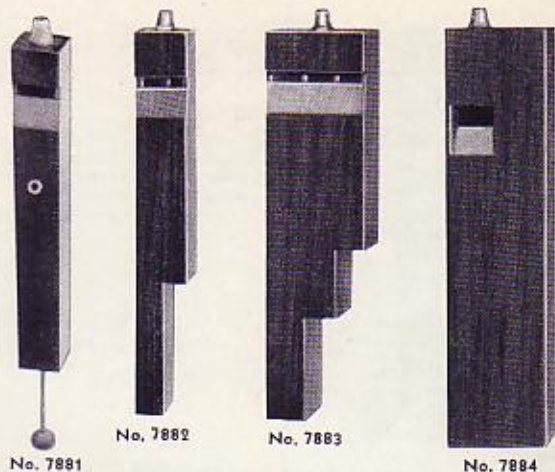

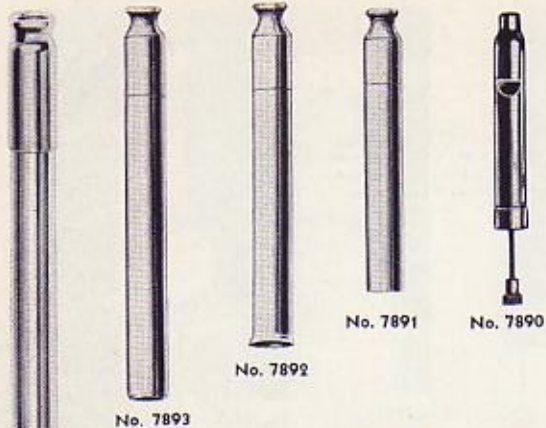

No. 7893

No. 7892

No. 7891

No. 7890



No. 7895

No. 7894



No. 7899



No. 7898



No. 7896



No. 7897

REALISTIC IMITATIONS**COW BAWL**

A perfect cow imitation, this trap is also used for other effects. Fine horse neigh effect obtained by over-blowing the first notes and fluttering the following while dying away. Made in three parts for packing.

No. 7894 \$2.00

ROOSTER CROW

Simply blow loud and soft, cupping the hands over the end for shading.

No. 7893 \$1.75

HEN CACKLE

Cupping the hands and sounding "cut-cut" produces the desired effect.

No. 7892 \$1.50

BABY CRY

High and low notes obtained by opening and closing of hands over end.

No. 7891 \$1.00

BOB WHITE and BOATSWAIN'S WHISTLE

Very shrill, and has considerable range. All metal, heavily nickered

*No. 7890 \$1.25

ALL-IN-ONE TRAP

Vulcanized rubber with a slide for adjusting the reed. Produces an excellent baby cry, hen cackle, cow bawl, pig grunt, duck quack, bee buzz, crow call, jay bird, horse laugh, grunt or snore.

*No. 7895 \$1.75

CROW CALL

A well made, durable, and very realistic crow call with a protected reed.

*No. 7896 \$1.25

DUCK QUACK

The most life-like of any duck calls. Used by hunters to attract wild ducks. Perfect imitation of pig grunts, monkey chatter and snore.

*No. 7897 \$1.25

SNORE IMITATION

A great comedy trap. Strength of breath controls loud and soft tones.

No. 7898 \$.30

NOSE BLOW

Allow rubber to flap against hand more or less for high and low tones.

No. 7899 \$.20

MACKINTOSH WATERPROOF DRUM COVERS

MADE WITH "PRESTO" SLIDE FASTENERS OR SNAP BUTTONS

Made with extra heavy, close weave, flannel lined, waterproof Mackintosh Cloth strongly sewed with reinforced seams. The "Presto" covers are equipped with a non-rusting metal interlocking slide fastener, which keeps the instrument fully protected from dust, dirt and grime. Opens and closes easily and quickly—just pull the metal tag and "PRESTO!", the job is done. Snap button covers are equipped with patented snaps—look for the gold Leedy "L" on each button.

Measurements Below Are For Drum Shells Only. We Make Full Allowance For Hoops, Rods, Etc. Be Sure to State Shell Measurements, Model of Drum, and Number of Cover.

FOR SNARE DRUMS		"PRESTO"	"SNAP BUTTON"
For 3"x12"—Junior Orchestra			No. 6770... \$2.75
For 7"x12"—Junior Parade			No. 6771... 2.75
For 3½"x13"—Nifty			No. 6772... 2.75
For 4"x14"—Pep	No. 6754	\$3.75	No. 6774... 2.75
For 5"x14"—Broadway Standard, Reliance, Utility	No. 6755	4.00	No. 6775... 3.00
For 6½"x14"—Broadway Standard	No. 6756	4.00	No. 6776... 3.00
For 6½"x15"—Broadway Standard	No. 6759	4.00	No. 6779... 3.00

NOTE: Form fitting "Presto" or "Snap Button" Covers made to order especially to fit Broadway Drums with Parallel and Dual Snare Strainers - - - 75c EXTRA

FOR BASS DRUMS		"PRESTO"	"SNAP BUTTON"
For 8"x22"—Junior Parade	No. 6800	\$7.00	No. 6820... \$5.00
For 8"x24"—Reliance	No. 6801	7.50	No. 6821... 5.50
For 12"x24"—Reliance	No. 6802	8.00	No. 6822... 6.00
For 12"x26"—Standard, Spartan, Reliance	No. 6803	8.50	No. 6823... 6.00
For 14"x28"—Standard, Spartan, Reliance	No. 6806	9.25	No. 6826... 7.25
For 14"x30"—Standard, Spartan, Reliance	No. 6808	10.00	No. 6828... 8.00
For 16"x30"—Standard, Spartan, Reliance	No. 6809	10.50	No. 6829... 8.50
For 16"x32"—Standard, Spartan	No. 6810	10.75	No. 6830... 8.75
For 16"x34"—Standard, Spartan	No. 6811	11.75	No. 6831... 9.50

SEE LEEDY "ROLL-OFF" NO. 3 FOR DRUM CORPS DRUM COVERS

"Presto" or "Snap Button" Covers made to order especially to fit Broadway Drums with Parallel and Dual Snare Strainers—75c EXTRA.

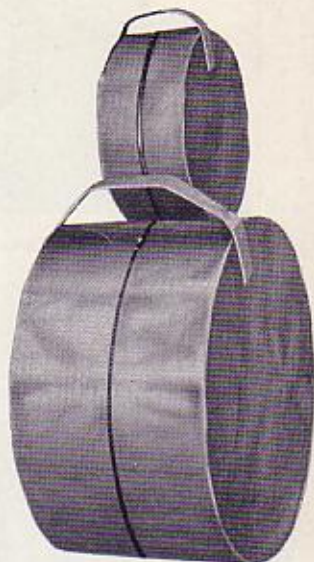

"Presto" Covers

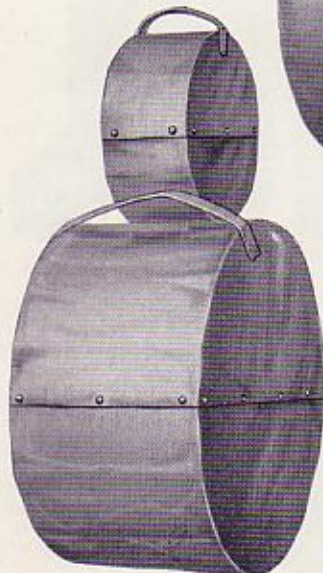

"Snap Button" Covers



No. 6841



No. 6851

No. 6861



No. 6865

No. 6870

CARRY-ALL FIBRE DRUM AND TRAP CASE*"The Finest of Them All"*

A case that will help ease the traveling drummer's burden. Holds more traps than any other model. Partitioned space in the main body takes all the "iron works", and a small Tom Tom if desired. Leather straps go all around case. Made of best grade vulcanized fibre, strongly riveted; has strong handle and reinforced corners. Fine appearance.

*No. 6840—4"x14" Shell \$13.50 *No. 6842—6½"x14" Shell \$13.50
 *No. 6841—5"x14" Shell 13.50 *No. 6843—6½"x15" Shell 13.50

ELITE SUIT CASE FIBRE MODEL

Like the Carry-All model, the Elite is high in quality and very spacious. It will hold almost as many traps, but is of a different shape. Tray 2½" deep. Made of vulcanized fibre strongly riveted. Has a fine lock, two snap catches. Fibre corners. Costs a little more, but well worth it. Wrap your drum stand, cymbals and holders in separate pieces of cloth—it protects their finishes from scratches, etc.

*No. 6850—4"x14" Shell \$16.00 *No. 6852—6½"x14" Shell \$16.00
 *No. 6851—5"x14" Shell 16.00 *No. 6853—6½"x15" Shell 16.00

SPECIAL SUIT CASE FIBRE MODEL

The Special is about the same shape as the Elite. By omitting some of the refinements we are able to offer it at a still lower price. There is a partition, fibre corners, lock and snap catches. Well worth the price.

*No. 6860—4"x14" Shell \$10.00 *No. 6862—6½"x14" Shell \$10.00
 *No. 6861—5"x14" Shell 10.00 *No. 6863—6½"x15" Shell 10.00

SQUARE AND ROUND TELESCOPE FIBRE DRUM AND TRAP CASES

The telescopic features of both these cases permit the drummer to carry more or less traps, as he desires. Simply place a sheet of fibre between the drum and the traps. Both cases are strongly made of the best vulcanized fibre—not the paper board variety. Strong straps and handles.

Square		Round	
*No. 6865—14" Shell	\$6.00	*No. 6870—14" Shell	\$6.00
*No. 6866—15" Shell	6.00	*No. 6871—15" Shell	6.00
*No. 6867—16" Shell	6.00	*No. 6872—16" Shell	6.00

SQUARE TELESCOPE FIBRE BASS DRUM CASES

Interstate Commerce Regulations rule against checking round containers on railroad trains. This case is designed to overcome that difficulty. Light, but strong. Keeps down your excess. Made of best grade black vulcanized fibre. Genuine leather straps and fibre corners.

*No. 6880—Size 26"x12" to 16" Deep	\$19.00
*No. 6881—Size 28"x12" to 16" Deep	20.00
*No. 6882—Size 30"x12" to 16" Deep	21.00
*No. 6883—Size 32"x12" to 16" Deep	22.00
*No. 6884—Size 34"x12" to 16" Deep	23.00

ROUND TELESCOPE FIBRE BASS DRUM CASES

This case is especially adaptable to automobile traveling. Being round, it can not be checked as baggage on the R.R. High grade materials.

*No. 6890—Size 26"x12" to 16"	\$19.00
*No. 6891—Size 28"x12" to 16"	20.00
*No. 6892—Size 30"x12" to 16"	21.00
*No. 6893—Size 32"x12" to 16"	22.00
*No. 6894—Size 34"x12" to 16"	23.00

BASS DRUM TRUNKS

The most moderately priced Bass Drum Trunk on the market. Built of three-ply basswood, fibre covered inside and out. Heavy pressed steel corners and clamps. Fine lock. Truly a wonderful trunk for the money and a necessity for the Drummer who uses the railroads. A Leedy trunk is real insurance to your instrument. Made in our own factory.

Please State Depth of Drum Shell When Ordering

‡No. 6900—For 26" Drum Shell	\$30.00
‡No. 6901—For 28" Drum Shell	30.00
‡No. 6902—For 30" Drum Shell	35.00
‡No. 6903—For 32" Drum Shell	35.00
‡No. 6904—For 34" Drum Shell	40.00

SPECIAL FIBRE CASES AND TRUNKS

Special fibre trunks and cases made for Tom Toms, Gongs, Tenor Drums, Traps, Consoles, Etc. made to order. Prices quoted on receipt of complete details concerning measurements, models, etc., etc.

Vibraphone—Xylophone—Marimba—Tympani and Chime Trunks and Cases
Listed on the same pages as the instruments



No. 6881

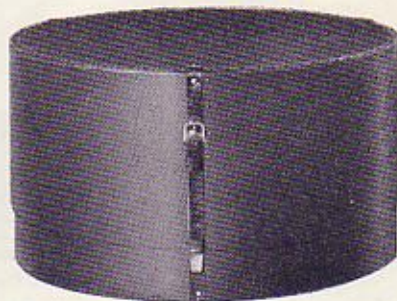

No. 6891



No. 6901

Leedy OWN MAKE QUALITY DRUM HEADS



John Gyuka



Just One of the Many Head Making Operations

THE WORLD'S FINEST

Leedy

LEEDY OWN MAKE QUALITY DRUM HEADS

We are ever mindful of the fact that the highest grade drum can be no better than its heads, therefore the Leedy Manufacturing Co. always devotes every effort to producing the finest snare, bass and tympani heads that skill, money and equipment can turn out. This department is under the supervision of John Gyuka, an expert who has had thirty years experience in this line of work, and whose technical skill—combined with our knowledge of what good heads should be—places us in a position to manufacture heads of the very finest quality. Leedy drum heads are made in our own factory, and always from the highest quality, fresh calf and cow hides. We maintain our own refrigerating plant for storing the skins. This keeps them in perfect condition for the short time between the killing and their start thru our plant. Many modern, specially built machines are used in the manufacture of these heads, but a great many of the stages thru which they pass require considerable skillful hand work.

The Superior "Hardwhite" and the Regular "Hardwhite" heads are noted for their resiliency in throwing back the sticks, and for their fine tight fibres, smooth finish and unusual whiteness. The "Uka" and "Kafette" heads are noted for their elastic fibres which produce long, resonant tones, and for their smooth surface, even texture and clearness. Leedy heads are the finest that money, raw materials and skill can produce.

DEMAND GENUINE LEEDY HEADS

Every genuine Leedy Drum head is stamped with its own trade mark. This is your assurance that every head you purchase will give the utmost in satisfaction provided it receives the ordinary care that all drum heads require. Attached to each genuine Leedy drum head is a guarantee label. On this label are complete instructions for properly tucking drum heads—just another helpful Leedy service for our customers.

AN IMPORTANT DRUM HEAD FACT

Drum heads, regardless of grade or quality, are products of nature. They break and tear from so many causes beyond the control of the maker and dealer that it is a business impossibility to guarantee them unreservedly. Therefore, before using a head examine it carefully and if unsatisfactory in any way return it, stating your objection. If we are unable to select one to suit you we will refund the purchase price. However, we positively can not guarantee or replace heads after they have been wet or subjected to usage, due to the nature of the product itself.

SUPERIOR "HARDWHITE" HEADS

Only the finest calfskin heads can give you the easy playing, sensitive response and the true drum tone that you have a right to expect from your drum. Leedy Superior "Hardwhite" heads give you all of that because they are processed to give maximum satisfaction in every way. Pure white in color with an unusually hard surface made possible by the firmer, tighter fibres due to the Leedy secret method of processing, these heads are therefore smoother, more damp-resisting, give greater rebound to the sticks, and are unusually sensitive as well as more durable. The finest heads on the market at any price.

Snare Drum—Batter Side Only

No. 5717—17" for 13" Shell...\$3.20	No. 5720—20" for 16" Shell...\$4.10
No. 5718—18" for 14" Shell... 3.50	No. 5721—21" for 17" Shell... 4.40
No. 5719—19" for 15" Shell... 3.80	No. 5722—22" for 18" Shell... 4.70

Bass Drum

No. 5728—28" for 24" Shell...\$7.20	No. 5734—34" for 30" Shell...\$ 9.30
No. 5730—30" for 26" Shell... 7.90	No. 5736—36" for 32" Shell... 10.20
No. 5732—32" for 28" Shell... 8.60	No. 5738—38" for 34" Shell... 11.20
No. 5740—40" for 36" Shell...\$13.20	

REGULAR "HARDWHITE" HEADS

These were our finest quality heads until we evolved the new method of processing used for the Superior "Hardwhite" heads described above. These likewise are hard, white tight-fibred heads of uniform, even thickness and respond quickly to the lightest stick tap.

Snare Drum—Batter Side Only

No. 5817—17" for 13" Shell...\$2.70	No. 5820—20" for 16" Shell... \$3.60
No. 5818—18" for 14" Shell... 3.00	No. 5821—21" for 17" Shell... 3.90
No. 5819—19" for 15" Shell... 3.30	No. 5822—22" for 18" Shell... 4.20

Bass Drum

No. 5828—28" for 24" Shell...\$6.00	No. 5834—34" for 30" Shell...\$ 8.10
No. 5830—30" for 26" Shell... 6.70	No. 5836—36" for 32" Shell... 9.00
No. 5832—32" for 28" Shell... 7.40	No. 5838—38" for 34" Shell... 10.00
No. 5840—40" for 36" Shell...\$12.00	

Prices of Drum Heads are Controlled by the Raw Material Market and are therefore Subject to Change Without Notice



LOOK

FOR THE LEEDY TRADE MARK

WHEN BUYING HEADS—

IT IS YOUR GUARANTEE

OF SUPERIOR HEAD QUALITY





TUCKING and
FLESH HOOP PRICES



"UKA" TRANSPARENT SNARE DRUM HEADS

These heads have stood a twenty-five year test and are the favorite of thousands of Drummers. Finished in the hide's natural state; meaning that the fibres are alive and flexible. Transparent and resilient.

Snare Drum—Snare Side Only		Snare Drum—Batter Side Only	
No. 5917—17" for 13" Shell	\$2.30	No. 6017—17" for 13" Shell	\$2.30
No. 5918—18" for 14" Shell	2.45	No. 6018—18" for 14" Shell	2.45
No. 5919—19" for 15" Shell	2.60	No. 6019—19" for 15" Shell	2.60
No. 5920—20" for 16" Shell	2.70	No. 6020—20" for 16" Shell	2.70
No. 5921—21" for 17" Shell	2.80	No. 6021—21" for 17" Shell	2.80
No. 5922—22" for 18" Shell	2.90	No. 6022—22" for 18" Shell	2.90

"KAFETTE" TRANSPARENT TYMPANI HEADS

"Kafette" Transparent Tympani Heads have been definitely established as the finest in the world. Always flexible and even in thickness, they assure fine, resonant tone and are the choice of the majority of leading tympanists in every phase of the business.

No. 6430—30" head for a 24" Tympani	\$ 7.90
No. 6431—31" head for a 25" Tympani	8.25
No. 6432—32" head for a 26" Tympani	8.60
No. 6433—33" head for a 27" Tympani	8.90
No. 6434—34" head for a 28" Tympani	9.30
No. 6435—35" head for a 29" Tympani	9.75
No. 6436—36" head for a 30" Tympani	10.20

HEAD TUCKING AND FLESH HOOP PRICES

No. 1973—Tucking Snare Drum Head (any size)	\$.50
No. 1974—Tucking Bass Drum Head (any size up to 40")	.75
No. 1975—Tucking Tympani Head (any size)	1.00
No. 1950—Metal Flesh Hoop for Snare Drum— (State whether Batter or Snare, and Shell Size)	.75
No. 1951—Wood Flesh Hoop for Snare Drum— (State whether Batter or Snare, and Shell Size)	.40
No. 1952—Wood Flesh Hoop for Bass Drum (State Shell Size)	.80
No. 1953—Metal Flesh Hoop for Tympani (State Shell Size)	2.00

Prices of Drum Heads are Controlled by the Raw Material Market
and are therefore Subject to Change Without Notice

DRUM HEAD FORM

This is a handy little device consisting of a "shell," two hoops and five rods for the purpose of carrying, or keeping, two drum heads already tucked on hoops. Keeps the flesh hoops from warping, and permits the drummer to have extra heads on hoops ready for instant use at all times.

Please specify Shell Diameter When Ordering

- No. 1967—For Heads on Wood Flesh Hoops \$2.00
 No. 1968—For Floating Head Drum Heads on Metal Flesh Hoops 2.00

Prices Do NOT Include Heads

METAL and WOOD COUNTER HOOPS

Metal—For Floating Head Drums

- No. 8120—Nickel \$2.50
 No. 8122—Chromium 3.75
 No. 8121—Nobby Gold 3.75

Metal—For Standard Model Drums

- No. 8117—Nickel \$2.00
 No. 8119—Chromium 3.00
 No. 8118—Nobby Gold 3.00

Important—State Whether for Batter or Snare Side—Also Shell Size

- No. 1954—Wood Counter Hoop for Snare Drum (See note below) \$1.50
 No. 1955—Wood Counter Hoop for Bass Drum (See note below) 2.00

Note—Wood Counter Hoops Guaranteed to Fit Only if Shell is Sent to Us. We Can Not Make Wood Counter Hoops From Diagrams.

PEARL INLAID WOOD COUNTER HOOPS

- No. 1970—For Snare Drum (State if for Batter or Snare Side) Ea. \$2.25
 No. 1971—For Bass Drum. (State size.) Each 3.50

Be Sure To Specify Pearl or Color of Sparkling Pyralin Wanted for Inlay

Important—Wood Counter Hoops Guaranteed to Fit Only if Shell is Sent to Us. We Can Not Make Wood Counter Hoops From Diagrams.

ELECTRIC SNARE AND BASS DRUM HEATERS (Patented)

This heater has proven a life saver for the drummer in damp weather. Does away with the need for continually tensioning the heads and pulling counter hoops too low. Let it rain—your drum will always be tight and snappy if you use this heater. It gives no light, and with ordinary care will never burn out. Is 9½" long, and ¾" in diameter. Six foot cord and two connecting plugs furnished. Can be left inside drum when transporting. Made to connect with a 110 volt incandescent lamp socket.

- *No. 1745—For Snare Drum, complete \$4.00
 *No. 1746—For Bass Drum, complete 4.00



No. 1967



No. 8120



No. 1970

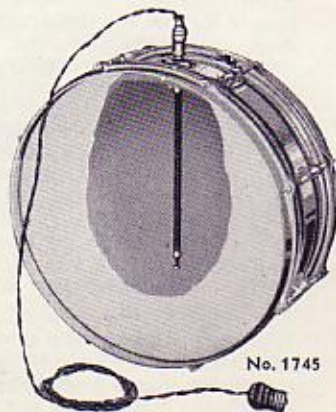

No. 1745

HOW TO TUCK DRUM HEADS

There are several ways of putting drum heads on the flesh hoops, but the best results are obtained by soaking the whole head in clear water for about ten minutes for snare drum and twenty minutes for bass drum. The head should then be laid, flesh side up, on a suitable table and smoothed out with the palm of the hand until it lies perfectly flat and even. The flesh hoop is then placed centrally on the head, allowing an equal margin all around for tucking, according to the size of the flesh hoop. It is often necessary to trim the head all the way around with scissors. The head should then be carefully folded over the hoop and tucked under the lower inside edge at four equal spaces to hold it in place. The tucking process can then be completed, being careful to avoid wrinkles or unevenness, and the head should be forced to the extreme outside edge of the hoop. If it turns up on the outside of the hoop and leaves a little ridge it will hold better than if it is just shoved under the lower side of the hoop.

After the head is placed on the hoop in this manner it should be put on the drum shell and tied securely around drum in the same manner as doing up a package, then allowed to dry thoroughly (which usually requires from eighteen to twenty-four hours) before the hoops, rods and other trimmings are put in place. If this method is followed there will be no danger of the head tearing around the edge, as they sometimes do when the drum is assembled while the heads are wet, which is due to them drying faster on the exposed surface than under the hoops, and the contracting action of the dried part tears the wet fibres apart. This course is not necessary with bass drum heads, as they are much heavier and stronger than snare drum heads and therefore can be assembled while heads are wet.

For tympani heads, soak heads in clear water for about twenty minutes, place about a 12" chopping bowl on the table *under* the head and tuck as described above and illustrated for metal flesh hoops in the next column. Let head dry thoroughly before putting on tympani, the slack in the head left by bowl will be taken up when the head dries.

ABOUT METAL FLESH HOOPS

Heads may be tucked on metal flesh hoops and carried indefinitely without the hoop becoming warped. This is a great advantage when it becomes necessary to make a quick change. When tucking a head on a metal flesh hoop, let it become **THOROUGHLY** dry before putting on drum shell. Heads will never slip off metal flesh hoops if they are correctly tucked. Be sure to shove the head all the way under the flesh hoop, allowing a little to go **BEYOND** the outside corner as shown in Fig. 1. Never tuck as shown in Fig. 2.



FIG. 1

HEAD



FIG. 2

HEAD

A DRUM HEAD FACT

It is not heat and cold that affect snare and bass drum heads—it is the condition of the heat and cold, viz: dampness and dryness. A damp heat will cause the head to slacken, and the same with a damp cold. A dry heat will cause a head to tighten, and the same with a dry cold. Therefore, watch the condition of the atmosphere rather than the thermometer and avoid head breakage. If you have tightened your head on a damp night, let it out after using to the point where you started to take it up. This will allow some slack for a "take-up" should the next day be dry. If your drum works nicely in dry weather, leave it alone.

A DRUM HEAD TIP

It is not always necessary to retuck a drum head. Sometimes it is very inconvenient to do so on account of the time required and the trouble of getting the head off the flesh hoop, especially if it is old and well tucked. Besides, there is the danger of tearing same. Submerge the whole head and flesh hoop in water—not too cold, but not warm—for three minutes, then allow it to dry slowly. If it is a good head it will contract. After it is practically dry you can put it on the shell and adjust same as usual. This will often result in as good a job as retucking.

THE ADVANTAGES OF CHROMIUM PLATING

The advantages of Chromium Plating are becoming better known every day. More and more drummers are demanding it on all metal parts of their drums and accessories. Hundreds have learned that its fine wearing qualities plus the more beautiful appearance makes it the most economical to choose, even though the cost is slightly higher than nickel.

Chromium Plating IS the most beautiful, practical and durable plating known for accessories and the metal parts on drums. It has a bright, reflective bluish-white cast that surpasses all other platings in appearance. It is as easy to clean, and keep clean, as glass itself. Polishing and rubbing are never necessary—merely wiping occasionally with a slightly dampened soft cloth keeps it in the-day-it-was-bought condition. It is rust-resisting to a greater degree than any other plating known.

"Why does a Chromium Plated article cost more than the same article in Nickel" is a question that is asked often enough to make us believe that all Drummers who receive this catalog may be interested in the answer. The work and time required to Chromium Plate an article is approximately five times that required to Nickel Plate it. Nickel Plating is done mechanically in three operations, WHILE CHROMIUM PLATING REQUIRES EIGHT MAJOR OPERATIONS AND TWICE THAT MANY MINOR OPERATIONS—ALL OF WHICH ARE DONE BY HAND. Items ordered in Chromium receive THREE COMPLETE PLATINGS—a Copper, then a Nickel, and finally the Chromium. The two preliminary platings are essential in order to produce the best quality work such as found on Leedy metal parts when ordered in this finish.

Chromium prices are not determined arbitrarily—they are based on actual costs and, considering the manifold advantages of this marvel plating, are really very reasonable.

NOBBY GOLD— ADVANTAGES AND DISADVANTAGES

Nobby Gold is indeed beautiful in appearance and with proper care will last for a long time. However, it is not real gold, but is admittedly a brass plating, lacquered as a last operation. When the lacquer wears off, as it is bound to do when coming in contact with other metal objects, or in rough handling, the brass plating itself naturally turns dark in color. While it is a beautiful finish and goes better with certain color combinations than any other plating, its wearing qualities are limited and we advise Drummers to choose Chromium instead.

Nobby Gold should never be cleaned with any form of polish and hot water should never be used, as either one will remove the lacquer. The best method for cleaning is to use a light oil, such as 3-in-1, on a soft cloth.

We seriously advise against Nobby Gold plating on outdoor drummers' equipment, such as street drums, etc. Chromium looks much better and will stand up a great deal longer.

JUST A WORD ABOUT REFINISHING OLD DRUMS

It takes about five times as long to remove the old finish from a drum and to apply the new finish as it does to apply the finish to a new product. New color finishes cannot be applied over the old varnish finish on a drum, nor can any "Full Dress" Pearl or Sparkling Pyralin finish be applied over a varnish or color finish. Prices for refinishing drums depend largely on the condition of the drum shell itself, and estimates for this work can be given only after the drum has been sent to the factory for our inspection. Drums sent to the factory for refinishing, or quotations on refinishing, must be shipped *prepaid*, and the cost of returning the drum must necessarily be added to the invoice. Ten days to two weeks, plus the necessary shipping time, is required for this type of work.

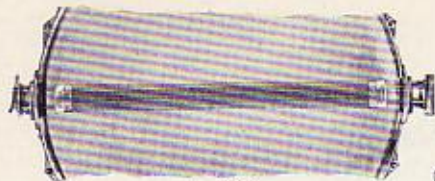

No. 8100



No. 8102



No. 8105

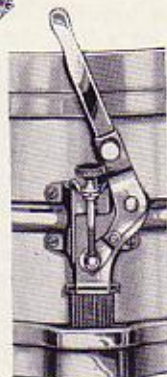

No. 8190



No. 8201

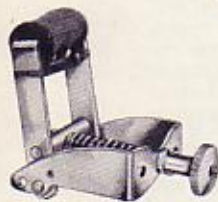

No. 8091



No. 8135



No. 1985

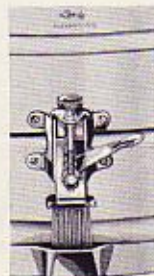

No. 8199

JAMES SNARES

Twelve non-rusting all-steel wire snares built into a unit by soldering to metal end plates. Snares do not pass over the edge of shell.

No. 8100—12 Snares for 14" Shell—complete, Per Set. \$2.50
No. 8101—12 Snares for 15" Shell—complete, Per Set. 2.50

GUT SNARES

Carefully processed, and finished with a smooth, glassy-hard surface.

No. 8102—For Orchestra—Set of 12 \$1.80
No. 8103—For Band—Set of 12 2.00

State Shell Diameter on Order

SILK WIRE WOUND SNARES

Non-rusting steel wire wound uniformly around a white all-silk core.

No. 8105—For Band and Orchestra—Set of 12 \$1.00
No. 8106—For Drum Corps—Set of 12 1.00

State Shell Diameter on Order

SNARE STRAINERS

No. 8190—Speedway Snare Strainer, with jaws—Nickel \$3.50
No. 8192—Speedway Snare Strainer, with jaws—Chromium 5.00
No. 8191—Speedway Snare Strainer, with jaws—Nobby Gold 5.00
No. 8199—Presto Muffler Snare Strainer, with jaws—Nickel Only 2.50

EXTRA "BROADWAY" SNARES

Extra Automatic Tension Snares for Broadway Parallel and Dual drums on bow spring holder mounted and ready for instant installation on drum. Bow keeps snares tensioned.

State Shell Diameter When Ordering

No. 8201—Silk Wire. Comp. \$3.50
No. 8202—James. Complete 3.50
No. 8203—Gut. Complete 3.50

INTERNAL TONE CONTROL

Installed *inside* the drum shell as shown on page 8. Felt pad presses against *inner side* of batter head to eliminate "ring" and control the tone. Operated by *external* knob.

No. 8091—Nickel \$.75
No. 8092—Chromium95
No. 8093—Nobby Gold95

Installation \$1.50 Extra Plus Express

FIBRE HEAD PROTECTORS

Be Sure to State Shell Size

No. 8135—For Snare Drum \$.75
No. 8136—For Bass Drum 2.00
No. 8137—For Tympani 2.00

SQUARE HEAD DRUM KEYS

For All Leedy Key Tensioning Drums

No. 1985—Nickel \$.20
No. 1987—Chromium30
No. 1986—Nobby Gold30

DRUM RODS AND PARTS

These Items Sold Only for Repairs and Not in Quantities

SELF-ALIGNING CENTER SUPPORTS

For separate tension snare drums—with two receiving tubes, etc.

No. 8140—Nickel	\$.80	No. 8142—Chromium	\$1.20
No. 8141—Nobby Gold		\$1.20	

SQUARE HEAD COLLAR SCREWS (Rods)

For use on separate tension snare and bass drums. Washer included.

No. 8130—Nickel	\$.15	No. 8132—Chromium	\$.25
No. 8131—Nobby Gold		\$.25	

Be Sure to State Shell Size

COLLAR HOOKS

For use on separate tension snare drums with metal counter hoops.

No. 8125—Nickel	\$.20	No. 8127—Chromium	\$.30
-----------------------	--------	-------------------------	--------

DOUBLE POST CENTER SUPPORTS

For use on metal or wood shell separate tension snare drums.

No. 8180—For 4" Shell-Nickel \$.60	No. 8181—For 5" Shell-Nickel \$.60
---------------------------------	-----	---------------------------------	-----

SCOTCH TYPE DOUBLE CLAW HOOK RODS

Snare Drum—Single Tension

No. 8160—Nickel	\$.75
No. 8162—Chromium	1.15

Snare Drum—Separate Tension

No. 8163—Nickel	\$1.50
No. 8165—Chromium	2.25

Bass Drum—Single Tension

No. 8167—Nickel	\$.75
No. 8169—Chromium	1.15

Bass Drum—Separate Tension

No. 8170—Nickel	\$1.50
No. 8172—Chromium	2.25

Be Sure to State Shell Size

TYMPANI MODEL BASS DRUM RODS

Single Tension with Center Supports

No. 8183—Nickel	\$.75
No. 8185—Chromium	1.15
No. 8184—Nobby Gold	1.15

Separate Tension

No. 8186—Nickel	\$1.50
No. 8188—Chromium	2.50
No. 8187—Nobby Gold	2.50

Be Sure to State Shell Size

THUMB SCREW SNARE DRUM RODS WITH CENTER SUPPORTS

For Snare Drum Only—Single Tension

No. 8174—Nickel	\$.65	No. 8176—Chromium	\$1.00
-----------------------	--------	-------------------------	--------

Be Sure to State Shell Size



No. 8140



No. 8163



No. 8160



No. 8130



No. 8174



No. 8125



No. 8174 With Center Supports



No. 8181



No. 8183



No. 8180



No. 8186



No. 1776



No. 1775



No. 1777



No. 1795



No. 1785



No. 1796



No. 1790

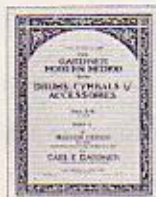

No. 1780



No. 1797

DRUM CORPS INSTRUCTORS



No. 1774



No. 1769



No. 1773

DRUMMERS' INSTRUCTION BOOKS

Frank A. Snow Instructor—A splendid instructor of rudimental drumming. Includes 15 exercises and 20 martial beats and quicksteps for drums, also 12 quicksteps for drums and bugles.

No. 1775 \$1.50

Dodge Drum School—One of the best. Complete and thorough, including every phase of the drummer's routine.

*No. 1776 \$2.00

Harry A. Bower Imperial Method—One of the oldest and best works available.

†No. 1777 \$1.25

Carl Gardner's Methods—Written by one of the world's foremost authorities. Covers every department.

†No. 1780—Drums and Traps \$2.00

†No. 1781—Bells and Xylophone 2.00

†No. 1782—Tympani 2.00

Sietz's Tympani School—Teaches the correct method of tuning and execution, with numerous exercises and illustrations.

No. 1790 \$3.00

Green Brothers' Beginner's Method—For Xylophone and Marimba. Starts at the very beginning and explains the various steps.

No. 1795 \$1.00

Green Brothers' Advanced Method—For Xylophone and Marimba. The finest obtainable. Positions, playing, improvising, and many jazz beats fully explained.

No. 1796 \$3.50

Leedy American Method For Bells—More than 100 pages of exercises and information.

No. 1797 \$2.00

Leedy Elementary Instructor For Vibraphone—A thoroughly comprehensive instructor for teaching the elements of music, positions, execution of the scales, chords, ear training, exercises and harmony. Illustrated.

No. 1785 \$2.50

DRUM CORPS INSTRUCTORS

Leedy Drum Corps Instruction Charts—Set of twelve wall charts 36"x36" describing and illustrating in minutest detail all the phases of the rudiments in the simplest, clearest and most concise manner ever devised. The surest and quickest way to learn drumming, and also the most practical means of teaching it because of their simplicity.

No. 1770—Complete Set of 12 Charts (Not Sold Separately) \$7.50

How to Twirl a Baton—Revealing the true secrets of baton twirling. Includes seventeen photographs and twenty-eight pen drawings showing the various movements and passes required in this art. Contains forty pages and is recognized as the authority on this hitherto complex subject. Every corps should have a "twirler."

No. 1773 \$1.00

Leedy Drum and Bugle March Book—Contains fifteen snappy marches scored for drums, G bugles and cymbals. Low in cost and highly valuable.

No. 1774 \$.50

Book of Military Drum Beats—Written by Geo. Lawrence Stone, one of the finest rudimental drummers in the country. Contains the original 26 drum rudiments with the approved accent markings, a number of marching taps and numerous individual exhibition beats which can be used by drummers as their selected numbers in drum contests.

†No. 1769 \$.75

XYLOPHONE SOLOS—BY JOE GREEN

No. 1818—XYLOPHONIA—Piano Accompaniment	\$1.00
No. 1819—DANCE OF THE TOY REGIMENT—17 Parts and Piano—(VICTOR RECORD No. 73438)	1.50
No. 1820—WHIRLWIND—10 Parts and Piano	1.25

XYLOPHONE SOLOS—BY HARRY BREUER—ALL WITH PIANO ACCOMPANIMENT

*No. 1663—BLUE TID BIT (4 hammers)	\$.75
*No. 1664—FOUR STICK JOE (4 hammers)75
*No. 1665—MINOR MOMENT (4 hammers)75
*No. 1666—HAPPY HAMMERS75
*No. 1667—POWDER PUFF75
*No. 1668—ON THE WOODPILE75
*No. 1669—BIT O' RHYTHM75
*No. 1670—CHOKIN' THE BELL (Vibraphone Solo)75
*No. 1671—50 MODERN RHYTHMIC BEATS	1.00

XYLOPHONE SOLOS—BY RALPH STRUBLE HANSELL—ALL WITH 10 PARTS AND PIANO

*No. 1826—KNOCKIN' AROUND	\$1.25
*No. 1827—XYLO-FUN	1.25
*No. 1828—CONGLOMERATION	1.25

XYLOPHONE SOLO—BY AL. "RAGS" ANDERSON—WITH 10 PARTS AND PIANO

*No. 1829—STEPPIN' ROUND	\$1.25
--------------------------------	--------

XYLOPHONE SOLOS—MARY ZOLLER ARRANGEMENTS—ALL WITH PIANO ACCOMPANIMENT

*No. 1672—MUSICAL MISS—Mary Zoller	\$.50
*No. 1673—RAINDROPS—Ben Garrison50
*No. 1674—SPOTLIGHTS—Ray Doll50

XYLOPHONE SOLOS—WITH 10 PARTS AND PIANO

No. 1821—STANDARD FAVORITES—Hacker	\$.50
No. 1822—SPLITTIN' KINDLING WOOD—Hacker50
No. 1823—DIXIE and VARIATIONS—Hacker50
No. 1824—PORK and BEANS—MacNeemer50
No. 1825—BEEFSTEAK and ONIONS—MacNeemer50

Improved

THE WORLD'S FINEST

Leedy

UNIVERSAL PEDAL TYMPANI

Leedy Universal Pedal Tympani have long been recognized by the great majority of leading professional drummers and tympanists in the highest class musical organizations all over the world as the finest machine type tympani ever invented. In mechanical design and detail, materials, construction and workmanship they surpass every former model. They include refinements found on no other tympani. They are practical in the fullest sense of the word. They are simple to tune, speedy to operate and easy to set up and take down. These instruments will enable you to master the highest type of percussion instrument with ease, which will in turn secure for you greater income and security of position in the drum field.



EASY, POSITIVE ACTION

PEDAL HOLDS FAST IN ANY POSITION

1-PIECE PERFECTLY SYMMETRICAL BOWLS

STRONG DOUBLE FLANGED COUNTER HOOPS

STANDS WITH WHEELS AND BRAKES OPTIONAL

The pedal action of Leedy Universal Machine Tympani is so light, positive and speedy and the compass so liberal (a complete octave) that chromatic scales, melody execution, "special effects" and "slurs" are very easily obtained.

Bowls are machine-drawn from one piece of finest quality copper. This drawing process assures a perfect symmetrical bowl of the proper proportions to produce that deep, rich, powerful and sonorous tone so greatly desired by those "in the know." Stands with rubber wheels and brakes for ease in moving the instruments are now optional at a slight extra charge. All tympani are carefully finished and supplied with famous "Kafette" heads.

*No. 5500—Standard Size, 25" and 28".
Bright copper bowls. Other metal parts nickel plated and polished aluminum. Per Pair (Without Wheels) \$350.00

*No. 5501—Symphony-Opera Size, 26" and 29".
Bright copper bowls. Other metal parts nickel plated and polished aluminum. Per Pair (Without Wheels) \$385.00

Sticks and Fibre Head Protectors Included

*Two Special Legs with Two Rubber Wheels (both with Brakes) \$15.00 Extra

*Hoops, Handles, Brackets, Etc. in Nobby Gold or Chromium \$30.00 Extra

Bowls in Glossy Black or White Duco—No Extra Charge

THE SUPERIOR TENSION SYSTEM

It should be carefully noted that kettle brackets (shown by Fig. 1 in drawing) are an integral part of the Leedy tension system. This means that when tuning the head to the lowest note (with the pedal up as far as it will go) the strain of the head tension is applied to these brackets and NOT to the rods. Therefore, all rods cannot help but pull with an equal amount of tension on each one as the stress becomes greater and greater on up the scale with the downward travel of the pedal.

NOTE THE "BUMP" ON EACH KETTLE BRACKET

This "bump" (as marked by Figure 2 in drawing) acts as a stop to the upward movement of the bell cranks (marked Figure 3) when the pedal is up as far as it will go (the head at its lowest note) and automatically transfers all the tension on the inside rods to the kettle brackets. This enables the tympanist to iron out the head in all six tension handle areas without placing more tension on one rod than on another. Therefore, as stated above, when the pedal travels downward this system assures that all six rods are pulling equally. This is one of the main reasons why Leedy Pedal Tympani are the choice of the finest professionals.

BOWLS AND STANDS

Our bowls are machine-drawn from one piece of the finest quality "Superior" copper. Machine-drawn bowls are better than the old hand-hammered type because they are absolutely uniform in thickness and in cubic air content, features impossible to obtain by the hand-hammered method. Only the best of steel for the parts subject to great strain and the best of cast aluminum are used in the stands. Leedy Pedal Tympani can be set up and ready to play in less than five minutes and taken down even more quickly. Only a few simple connections and no complicated adjustments are necessary. Complete instructions supplied.

THE DOUBLE-FLANGED COUNTER HOOPS

The drawing at the right shows the extra strong double-flanged counter hoop construction. No need for more than six tension handles because of its tremendous strength. Fewer handles mean less effort to tune.

NEW STAND LEGS WITH WHEELS AND BRAKES

These new "easy-wheeling" legs, which can be supplied for old Leedy Machine Tympani or purchased at a small additional charge on new instruments, are equipped with two rubber-tired wheels and brakes. You can now move your tympani about as easily as moving a xylophone or vibraphone. Locking brakes on the wheels prevent "creeping."

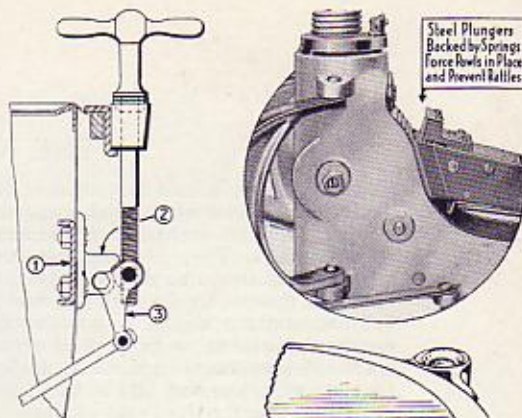

The Tension System

Double Flanged Counter Hoops



The Tilting Feature

Tympani can be tilted to any angle by means of an adjusting screw on the back of the stand. Can be adapted to fit into the close quarters of the theatre pit or on a small platform and played with comfort in a sitting position.

THE NEW REVOLVING MACHINE TYMPANI

And now Leedy meets the popular demand for low-priced Machine Tympani. This means that hundreds of professional as well as school band and orchestra drummers can own real high grade Machine models. They are marvels for tone qualities, speed and accuracy in tuning . . . you simply revolve the kettles—to the right for high notes—to the left for low notes. The action is easy and definite—only a slight turn required to change from one note to another. Nothing to get out of order, due to simple, practical and sturdy design, combined with careful construction. Will give perfect satisfaction and last a life-time. The bowls and many other parts are exactly the same as used on our Universal Pedal models.

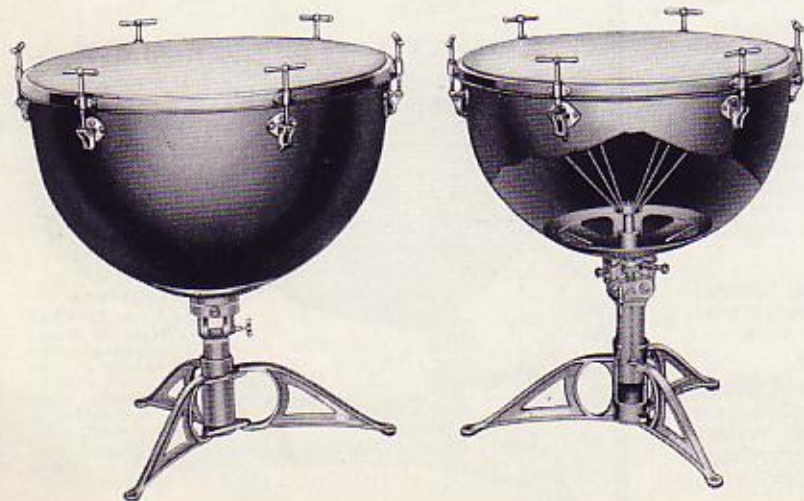

LOW IN PRICE

EASY POSITIVE ACTION

ADJUSTABLE TO HEIGHT AND ANGLE

ONE-PIECE PERFECTLY SYMMETRICAL BOWLS

The bowls are "drawn" from one piece of the best grade "Superior" copper to a perfect symmetrical trueness and finished to a lustrous satin copper sheen. Tension rods, handles, etc., are of finest quality steel heavily nickel plated. Stands are sturdy, of cast aluminum highly polished, and fold conveniently. Heads are the famous Leedy "Kafette" brand—the finest tympani heads made.

All kettles are adjustable to height and angle and therefore may be played in either a standing or sitting position. They also may be removed from the bases (or set up for playing) in two minutes time. The tympani kettle is attached to an aluminum seat which rolls on ball bearings. This seat is fixed to a screw which controls the tension rods by means of a key which is free to work up and down in the slot of the seat casting. The main adjusting tension screw threads into a nut which is held in place by three set screws, and as the main screw moves up and down it pulls or loosens the tension rods. A small screw, inside the larger one, prevents the kettle from being screwed out of its base.

*No. 5504—Revolving Machine Tympani, 25" and 28". Satin Copper Bowls, other metal parts heavily nickel plated, and polished aluminum.
Per Pair \$250.00

Sticks and Fibre Head Protectors Included

*Hoops, Handles, Brackets, Etc.
in Chromium \$30.00 Extra
*Hoops, Handles, Brackets, Etc.
in Nobby Gold 30.00 Extra

UTILITY HAND SCREW TYMPANI

LOWEST IN PRICE
COUNTER HOOPS BUILT LOW
SIX SELF-ALIGNING TENSION HANDLES
ONE-PIECE PERFECTLY SYMMETRICAL BOWLS

The bowls of Utility Tympani are made to exactly the same specifications as the other higher priced Leedy models shown. They are made in the same manner, being formed from one piece of "Superior" sheet copper. The kettles are reinforced on the inside by a double-beaded steel band and the edge of the bowl is turned over this band—all of which gives great strength to the "circle". They are finished with a beautiful satin copper lustre which contrasts pleasingly with the other metal parts. The six self-aligning tension rods, handles and lugs are of the best quality steel heavily nickel plated. Counter hoops are built low to permit freedom in execution. The Floating Head metal flesh hoops are zinc plated to prevent rusting, and stand 3/16" clear of the kettle at all points to prevent head binding—held in place at all times by the extension collar hooks through which the tension rods pass. Heads are the famous "Kafette" transparent tympani heads. The malleable iron stands are sturdy, accurately fitted, and fold compactly for convenience in packing and transporting.

These instruments are high in quality in every respect and compare very favorably with other makes of tympani on the market selling for considerably more. The materials used are the best. The simplicity of design and construction is the only reason for our being able to offer these exceptional instruments at the low price shown below.

*No. 5510—25" and 28". Satin Copper Bowls,
 Other Metal Parts and Stand
 Nickel Plated. Per Pair \$150.00

Stands, Sticks and Fibre Head Protectors Included

While Leedy Utility Hand Screw Tympani were designed primarily for School Band and Orchestra use—and are offered at a much lower price than any of our other models—they are high grade in every respect and have been used with remarkable success by hundreds of professionals in all branches of the business for the past ten years. We are able to offer them at a low figure solely because of their simplicity in design. There has been no "cutting corners" in material or workmanship. They are sturdy in construction and have a most excellent quality of tone and plenty of volume, even for the largest bands. They are used daily in dozens of the best theatres and finest school and college bands and orchestras.



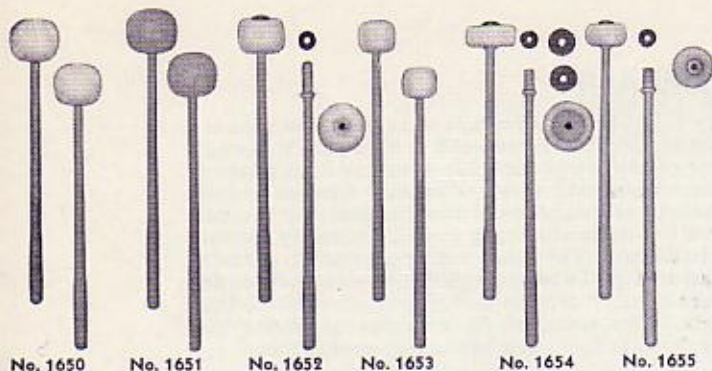

No. 1650

No. 1651

No. 1652

No. 1653

No. 1654

No. 1655



No. 7275



No. 1988



No. 6930



No. 6910



No. 6912



No. 6920

TYMPANI STICKS

Tympani Sticks are just as important in producing rich and resonant tones as the instruments themselves. They must be made with great care and of the finest materials. Leedy sticks are all of that. They are the choice of leading professionals.

	Per Pair
No. 1650—Professional Model, Felt	\$2.25
No. 1651—Artist Model. Lambs Wool	2.50
No. 1652—Symphony Model. Removable Felt Balls	2.50
No. 1653—Midget Model. Felt	1.75
No. 1654—Concert Model. Removable Felt Discs	3.00
No. 1655—Hard Model. Removable Solid Felt Discs	1.50

TYMPANI STANDS—PITCH PIPE—COVERS

A light, strong, steady, malleable iron tympani stand. Felt pads on support arms allow free vibration for full tone. Legs lock in open position. Carefully machined and finished.

*No. 7275—Nickel. Per Pair	\$12.00
*No. 7277—Chromium. Per Pair	18.00
*No. 7276—Nobby Gold. Per Pair	18.00

Tympani Pitch Pipe is Chromatic, one octave, C to C. Accurate in pitch. Indispensable to the beginner.

*No. 1988—Each	\$1.75
----------------------	--------

These covers assure protection from dirt, dust, etc., when the instruments are not in use. The material is heavy, fleece-lined, waterproof Mackintosh cloth, with a deep hanging "skirt".

No. 6930—Per Pair (State Size of Kettles)	\$7.50
---	--------

TYMPANI TRUNKS

Trunks are the only safe way for transporting tympani. Leedy Tympani Trunks are noted for their strength and durability. Made of 3-ply basswood, with vulcanized fibre inside and out. Strongly reinforced corners, quality hardware, and inside fittings for the full protection of the instruments.

Please State Size of Tympani When Ordering

‡No. 6910—For Universal Pedal Tympani. Per Pair	\$90.00
‡No. 6912—For Revolving Machine Tympani. Per Pair	85.00
‡No. 6920—For Utility Hand Screw Tympani. Per Pair	65.00

AUTHENTIC COMPASS CHART OF THE LEEDY MALLET PLAYED INSTRUMENTS

(Chart Shows Compass of Instruments Compared to the Standard 88-Note Piano Keyboard—Low Pitch A-440)

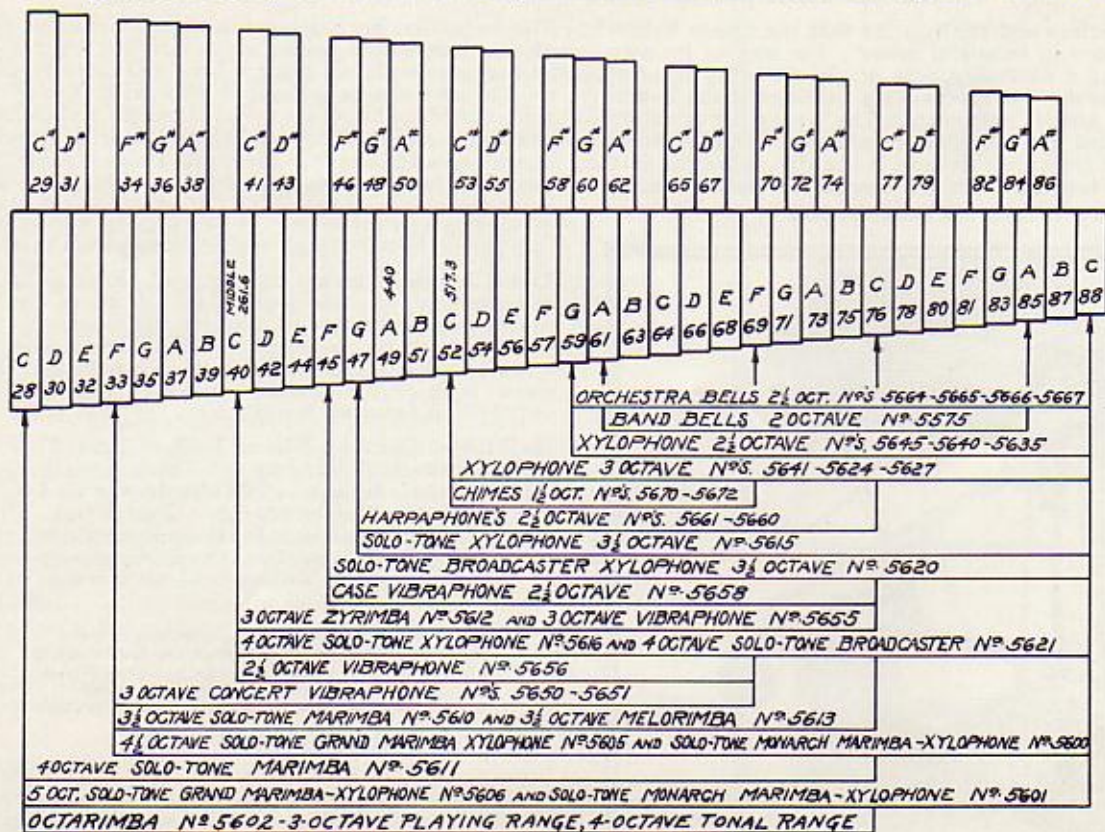

Music for mallet played instruments is customarily written two octaves lower than it actually sounds. Chime music, however, is usually written only one octave lower than it actually sounds. For example—the high C of orchestra bells (note C-88 on the chart) is identical in pitch to the highest C note on the piano but its musical notation is actually two octaves lower (C-64). The highest chime note (F-69) is written one octave lower than it sounds and receives the same notation on the staff as F-57 in the piano score.

CONCERT VIBRAPHONE

THIS INSTRUMENT INVENTED AND PERFECTED BY LEEDY

It is agreed by musicians and public alike that the Leedy Vibraphone is "the ultimate in beautiful tones". By way of its own merits it has become a necessary part of almost every musical program and has done more to increase the earnings of the Drummer than any other single instrument. The Leedy organization invented and perfected the Vibraphone and, while improvements have been developed from time to time, it has always led the field in beauty of design, tone qualities and mechanical perfection.

MADE WITH LEVEL BAR MOUNTING ONLY



The exquisite, enchanting vibrato and mellow tone of this instrument makes an everlasting impression on the listener. It has great volume and carrying power. Its tone can be compared only with that of the pipe organ because of its celestial beauty and pathetic sweetness, which blends so beautifully with all other instruments and the human voice. These are the reasons for its unequalled success in almost every program on the air, in the dance orchestra, on the stage, in phonograph recording, in the theatre pit, in concert bands, in the school, the home and the church.

The Vibraphone serves equally well either as an accompaniment, or solo instrument. A speed control enables the performer to regulate the vibrato to suit the character of the number being played, and the vibrato makes it unnecessary to roll with the hammers. It is an easy instrument to master. Note its outstanding features described on the next page.

No. 5650—3 Octaves, F-33 to F-69, 37 Bars, 2" to 1½" Wide by ½" Thick. Length 51". Height 34". Width Lower End 29". Weight 113 Lbs. "Full Dress" Finish—Black Pearl on Four Sides of Frames, Polished Aluminum Bars, and Nobby Gold on Resonators and Stand \$375.00

Instructor and Five Pair Choice Mallets Included
Following Finishes On Special Order--10 Days Required
Choice of Other "Full Dress" Pearl, Sparkling or Duco
Finishes on Wood Frames--No Extra Charge
Nobby Gold on Resonators, Stand, Etc.--No Extra Charge

VIBRAPHONE TRUNK

Strongly constructed of wood and fibre to give the instrument maximum protection. Quality hardware.

†No. 6935—Trunk, complete with trays \$85.00

VIBRAPHONE FEATURES

EASY DAMPER ACTION

The slightest pressure of the foot operates the damper and controls the duration of the tone. This gives the Vibraphone unlimited scope. Numbers of any character, including rapid passages, may be played, as the use of the damper eliminates the overlapping of chords or arpeggios. The pedal may be moved to the right or left and locked in position. The pull rod is adjustable to length—which corrects uneven floor conditions. Pedal needs only a $\frac{1}{2}$ " movement to operate damper.

STRONG, RIGID STAND AND WHEELS WITH BRAKES

The stand is sturdily built to withstand the severe usage even of "one night stands". Legs and braces are of heavy angle steel held by large thumb screws which do not back off the threaded studs. Slotted braces slide sidewise over the threaded studs instead of lifting off. The studs are cone shaped, and the braces will not come away even if the thumb screws are not tight. Every part of the stand is carefully fitted and finished. The wheels are 5" in diameter, are equipped with rubber tires and two rear wheels have efficient lock brakes.

REMOVABLE TEMPERED ALUMINUM BARS

The Leedy Vibraphone is equipped with bars of the newest aluminum alloy, scientifically tempered. This alloy produces the utmost in smooth, clear, mellow tones, with unusual vibratory and resonant sustaining qualities. The bars are suspended on heavy cords running thru open end slotted posts and are easily removed for packing by simply lifting them free of the frames. There are no projecting parts above the surface of the bars to interfere with the mallets. This type of mounting permits the maximum degree of volume from each bar.

FRAMES LOCK TO STAND

Frames cannot become separated from the stand. A small button on the outside of the metal end boxes operates the lock.

TRUNKS AND CASES

Vibraphone trunks and cases, made of combination wood and fibre respectively, are stoutly made of the finest materials and blocked and padded for fullest protection of the instruments—the finest on the market at any price.



Strong Rigid Stand and Wheels With Brakes

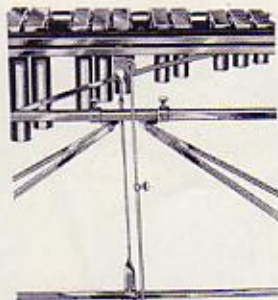

Easy Damper Action



Removable Tempered Aluminum Bars



Frames Lock to Stand

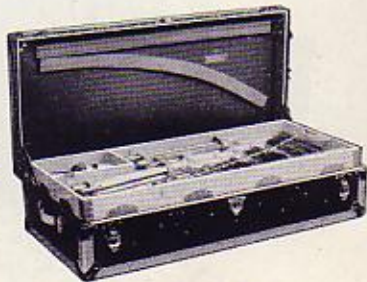

Strong, Leedy Made Trunk

LIGHT WEIGHT VIBRAPHONE

While the Light Weight Vibraphone is especially designed for the jobbing Drummer and is all that the name implies, it has practically all of the same features as the large Concert model. Of course the bars, resonators and stand are smaller, but the volume is almost equal. Many can not tell the difference. It has the same sweet, pulsating tone, with ample carrying power for the largest auditoriums. All parts are of the finest quality materials and the stand is both sturdy and rigid. In appearance this instrument is all anyone could desire. Made in a choice of either $2\frac{1}{2}$ or 3 octaves. Can be set up and taken down in very little time, and packs in two fibre hand carrying cases.



Now you can take a real Vibraphone with you on every job. The Light Weight will travel in automobiles, buses and street cars with no more trouble than large suit cases. The bars are of the same special aluminum alloy and suspended in the same manner as on the Concert model. Also the same 110 volt Universal motor with speed regulator, and the same type damper with locking device is used on this as on the larger instrument. Bars tilt, and legs may be removed for playing in a sitting position. Equipped with four rubber-tired wheels—two with brakes.

MADE WITH LEVEL BAR MOUNTING ONLY

- No. 5655—3 Octaves, C-40 to C-76, 37 Bars, $1\frac{1}{2}$ " to $1\frac{3}{4}$ " Wide, by $\frac{1}{2}$ " Thick. Length 44". Height With Wheels for Standing Position 35"; Without Wheels for Sitting Position 27". Weight 67 lbs. Finished with "Full Dress" Black Pearl on Wood Frames, Chromium Plated Stand and Polished Aluminum Bars and Resonators \$295.00
- No. 5656— $2\frac{1}{2}$ Octaves, C-40 to F-69, 30 Bars, $1\frac{1}{2}$ " to $1\frac{3}{4}$ " Wide, by $\frac{1}{2}$ " Thick. Length 38". Height With Wheels for Standing Position 35"; Without Wheels for Sitting Position 27". Weight 62 lbs. Finished with "Full Dress" Black Pearl on Wood Frames, Chromium Plated Stand and Polished Aluminum Bars and Resonators \$270.00

Instructor and Four Pair Choice Mallets Included

Following Finishes on Special Order--10 Days Required

Choice of Other "Full Dress" Pearls, Sparkling or Duco Finishes on Wood Frames--No Extra Charge

Nobby Gold on Resonators, Stands and End Boxes--No Extra Charge

HAND CARRYING CASES

- †No. 6925—2 Cases for 3 Oct. Wgt. 103 lbs. \$45.00
 †No. 6926—2 Cases for $2\frac{1}{2}$ Oct. Wgt. 87 lbs. 40.00

*Improved***PORTABLE CASE VIBRAPHONE**

The Leedy Case Vibraphone is built in a strong carrying case—ideally convenient for the jobbing drummer since there is no stand to assemble, no frame to attach, no bars or resonators to mount. Simply remove the cover from the case, plug in the cord, and you are ready to play—all in less than a minute.

The tempered aluminum bars, though smaller, are of the same quality stock as used on both the Light Weight and Concert models. They are suspended in mid air, which assures maximum vibration and volume of tone. The aluminum resonators lie horizontally in the bottom of the case to conserve space. The revolving fans in the tops of the resonators revolve in perfect unison, insuring an even vibrato. The number of fan pulsations per second (which determines the vibrato) is regulated by a new type governor over which the performer has positive control at all times. A damper bar is located so it may be operated with any finger of either hand while playing, the action being similar to that of the typewriter space bar.

The motor which turns the resonator drive shafts is a small, sturdy Universal (110 volt AC or DC) motor which operates from any light socket, and which will give long continual service and satisfaction with ordinary care and usage. A generous cord, plug, and light socket attachment are included with the instrument, of course. An instructor is also included.

This wonderful instrument will create new opportunities for you in your regular work.

No. 5658—2½ Octaves, F45 to C76, 32 Bars
1¼" Wide by ¾" Thick. Case 35"
Long by 20" Wide by 5" Deep.
Total Weight 44 lbs. \$195.00

**Instructor, Four Pair Choice Mallets and
Detachable Music Rack Included**

No. 1752—Folding Stand as Illustrated—Nickel \$6.00
No. 1753—Folding Stand—Chromium 9.00

Think of it! A genuine Leedy Vibraphone built right in its own convenient hand-carrying case, and the whole outfit so compact and light in weight that all the advantages of this enchanting instrument can be yours on every job you play. Weighs only 44 lbs.—little more than some sets of orchestra bells, and it is smaller in size than most xylophone carrying cases. Yet it is thoroughly practical and efficient for the great majority of drummers' needs. Has the same captivating sweet vibrato tone as the larger model Vibraphones, although its volume and carrying power are a little less because of its smaller dimensions. See and try this instrument at your nearest Leedy Dealer's store.

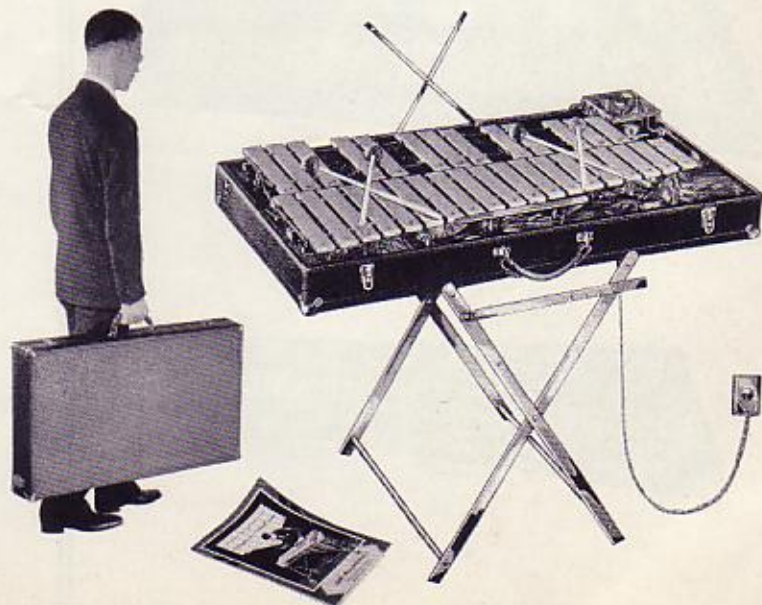

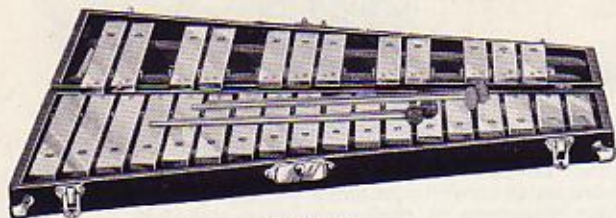

No. 5664

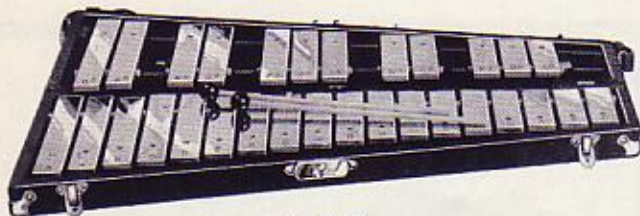

No. 5666



No. 5667

THE WORLD'S FINEST

Leedy

TEMPERED ALUMINUM BELLS

Bars of specially tempered aluminum alloy which are ideal for radio work because overtones are reduced to an absolute minimum and "hammer impact" is far less noticeable. The tone is unusually sweet, clear and volume is ample for the largest band and orchestra. Case is 3-ply wood, reinforced and Fabrikoid covered. Hardware and carrying handle are finest quality.

No. 5664— $2\frac{1}{2}$ Octaves, G-59 to C-88, 30 Bars $1\frac{1}{4}$ " Wide by $\frac{3}{8}$ " Thick. Case 28" Long by 11" Wide by 3" Deep. A-440 Pitch. Weight 15 lbs. Fabrikoid Covered Case. Complete with Detachable Music Rack and 2 Pair Selected Mallets \$50.00

STANDARD BELLS

Bars are of finest quality, specially carbonized steel with resulting excellent tone and splendid carrying power. Bars are accurately tuned and pitched perfectly. Regarded by thousands of professional drummers as the finest steel bells made. Especially designed for all kinds of fine orchestra and band work.

No. 5666— $2\frac{1}{2}$ Octaves, G-59 to C-88, 30 Bars $1\frac{1}{4}$ " Wide by $\frac{5}{16}$ " Thick. Case 29" Long by 12" Wide by $2\frac{3}{4}$ " Deep. A-440 Pitch. Weight 29 lbs. Fabrikoid Covered Case. Bars Chromium Plated. Complete with Detachable Music Rack and 2 Pair Selected Mallets \$45.00

EASY CARRY BELLS

Light in weight and easy to carry. Bars are of the same specially carbonized steel as used in the Standard Bells, and have the same excellent tone with carrying power suited to the majority of average needs. Bars are slightly smaller than those in the set listed above and volume is slightly less.

No. 5667— $2\frac{1}{2}$ Octaves, G-59 to C-88, 30 Bars 1" Wide by $\frac{1}{4}$ " Thick. Case 24" Long by 10" Wide by $3\frac{1}{2}$ " Deep. A-440 Pitch. Weight 17 lbs. Chromium Plated Bars and Fabrikoid Covered Case. Complete with Detachable Music Rack and 2 Pair Selected Mallets \$35.00

REAL LIGHT BELLS

A very light, high quality set of bells made to sell at an exceptionally low price. Bars are the same size and made of exactly the same fine quality specially carbonized steel as is used in both the Leedy Standard and Easy Carry Bells, but unpolished and unplated. The tone and volume compares favorably to that of the Easy Carry bells. Bars are mounted on a fine grade of piano felt and pegged to the wood frame. While designed especially for school use, these bells are used by many drummers who do considerable jobbing work because of their light weight. NOT a toy in any sense of the word. Case sold separately.

- No. 5668—2½ Octaves, G-59 to C-88, 30 Bars 1" Wide by ¼" Thick. 25" Long by 15" Wide by 2½" Deep.
Mallets Included (without Case)\$15.00
- †No. 6936—Fabrikoid Carrying Case for Real Light Bells,
(illustrated with Bells at left)\$7.00 Extra

FOLDING BELL STANDS

Both models are strong, rigid, light in weight, and fold compactly. No. 7285 has an 8" height adjustment. No. 7280 can be used also as a trap table. Carefully made and assembled.

- No. 7285—Nickel\$6.00
No. 7280—Nickel 6.00

STUDIO TUNING BAR

A Flip O' The Finger Sounds It! The rubber sounding ball eliminates all harsh impact when struck. No mallet is needed. Bar is of highly carbonized steel which gives a rich, long-sustained note that is definitely accurate in pitch. Wood resonator which also serves as a base is finished in beautiful Silver Duco. Provided with a hanger so it may be hung on the wall if desired. As fine and accurate a tuning bar as can be bought at any price and one that will serve you faithfully in every way. Substantially made and beautifully finished.

- No. 5700—A-440 Pitch\$7.00
No. 5701—Bb-466.2 Pitch 7.00
No. 5702—C-523.3 Pitch 7.00

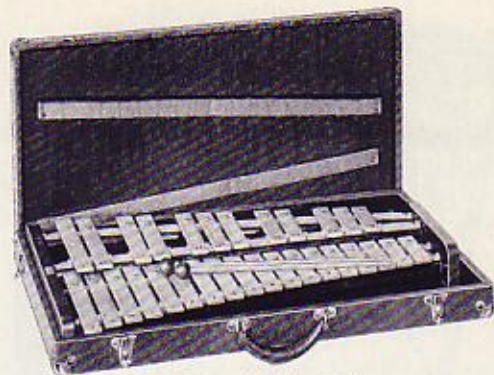

No. 5668, in Case No. 6936



No. 7285



No. 7280

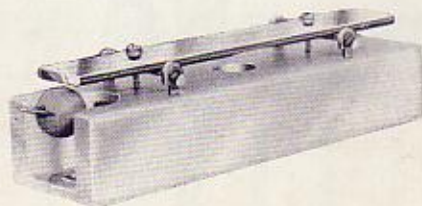

No. 5700



Case
For No. 5660

No. 5660

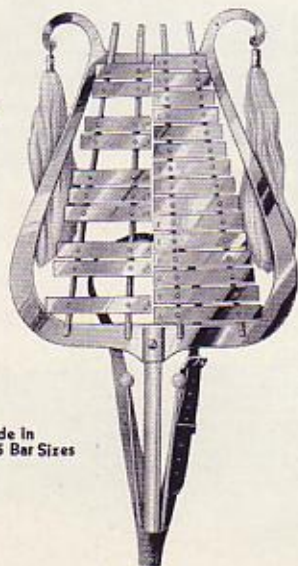

Made in
22 and 25 Bar Sizes

No. 5575
With Carrying Strap No. 1909

THE IMPROVED HARPAPHONE

MADE IN TWO MODELS—ON STAND OR IN CARRYING CASE

For organizations desiring the utmost in full, rich bell tones, there is no instrument that compares with the Harpaphone. The bars are larger than those of standard case bells, and each bar has a tuned metal resonator to amplify the tone. Will "top" the largest military band, or, with soft mallets, will give forth the sweetest, most mellow tones.

Built either on a stand as illustrated, or in its own carrying case with "crooked" resonators built right in the case like those of the Leedy Portable Case Vibraphone. Bars are Chromium plated carbonized steel of the finest quality. Silver Duco frame and Chromium stand.

- No. 5660—Harpaphone on Stand, $2\frac{1}{2}$ Octaves, G-47 to C-76, 30 Bars $1\frac{1}{2}$ " Wide by $\frac{1}{4}$ " Thick. Length 35". Height with Wheels 33"; without Wheels 25". Weight 42 lbs. \$115.00
 †No. 6940—Carrying case for Harpaphone on Stand \$20.00 Extra

Choice of "Full Dress" Pearls on Wood Frames--\$8.00 Extra
 Nobby Gold on Bars, Resonators and Stands--\$25.00 Extra

- No. 5661—Harpaphone Built in Case. Removable Lid. Length 34", Width 20", Depth $4\frac{1}{2}$ ". Weight 42 lbs. \$115.00

BELL LYRA

The flashiest instrument made for marching and concert bands. It is the old-time Bell Lyra brought up-to-date with sweeter, more penetrating tones, and greater volume than any former model. Carried in a strap like the "colors" and played with a mallet held in one hand while it is steadied with the other. The bars are of aluminum alloy, mounted chromatically. Aluminum frame. Light in weight and easily carried. Used on a stand for concert playing. Plumes and mallet included.

- No. 5575—25 Bars, A-61 to A-85, $1\frac{1}{4}$ " Wide by $\frac{3}{8}$ " Thick. A-440 Pitch. Weighs $15\frac{1}{2}$ lbs. \$85.00
 No. 5776—22 Bars, C-64 to A-85, $1\frac{1}{4}$ " Wide by $\frac{3}{8}$ " Thick. A-440 Pitch. Weight 13 lbs. 75.00
 No. 1909—Carrying Strap for Nos. 5575 or 5776 4.00
 No. 6837—Mackintosh Cover for No. 5575 6.00
 No. 6838—Mackintosh Cover for No. 5776 6.00
 No. 7288—Concert Stand for Bell Lyra. (State if for No. 5575 or 5776) 15.00

BELL—XYLOPHONE—MARIMBA AND VIBRAPHONE MALLETS

Each pair of mallets in the Leedy line is given individual attention. We insist on the very best of workmanship and use only A-1 materials. All are matched for balance and even weight. It is the most complete line on the market. There is a pair for every type of playing. If you have any questions in mind write us—we are at your service.

Brass Per Pair
 No. 1701—Solid Brass, Nickel Plated, 3/4" Balls, Flexible Reed Handles \$.50

Rawhide
 No. 1705—Seven-eighths Hard Rawhide, Oval, 1 1/8" Detachable Balls, Flexible Reed Handles 1.75

Graded Rubbers
 No. 1704—Soft Rubber, Oval, 1 1/8" Balls, Flexible Reed Handles50
 No. 1709—Soft (Red) Rubber, 1" Balls, Stiff Cane Handles60
 No. 1710—Soft (Red) Rubber, 1 1/8" Balls, Stiff Cane Handles75
 No. 1714—Half-Hard (White) Rubber 1" Balls, Stiff Cane Handles60
 No. 1715—Half-hard (White) Rubber, 1 1/8" Balls, Stiff Cane Handles75
 No. 1712—Three-quarter Hard (Green) Rubber, 1" Balls, Stiff Cane Handles60
 No. 1713—Three-quarter Hard (Green) Rubber, 1 1/8" Balls, Stiff Cane Handles75

Vulcanized Rubber Per Pair
 No. 1702—Polished Vulcanized Rubber, 1" Balls, Flexible Reed Handles \$.60
 No. 1703—Polished Vulcanized Rubber, 1 1/8" Balls, Flexible Reed Handles75

White Pyralin
 No. 1707—Seven-eighths Hard (White) Pyralin, 1" Balls, Stiff Cane Handles, (Friscoe Model) 1.25
 No. 1706—Seven-eighths Hard (White) Pyralin, 1 1/8" Balls, Stiff Cane Handles, (Friscoe Model) 1.50

Felts
 No. 1720—Soft Solid Felt, 1 1/4" Balls, Flexible Reed Handles, (Practice Mallets)75
 No. 1721—Hard Spanish Solid Felt, 1 1/2" Balls, Flexible Reed Handles 1.50
 No. 1722—Soft Solid Felt, 1 3/4" Balls, Flexible Reed Handles 1.25
 No. 1723—Hard Spanish Solid Felt, 1 1/2" Balls, Stiff Cane Handles 1.50
 No. 1724—Soft Solid Felt, 1 3/4" Balls, Stiff Cane Handles 1.25

Leather
 No. 1727—Soft Leather Slap Mallets for "Hot" Marimba, Hickory Handles 2.50

Yarns
 No. 1732—Yarn, Tight Wound, 1 1/8" Balls, Stiff Cane Handles 1.00
 No. 1728—Yarn, Tight Wound, 1 1/4" Balls, Stiff Cane Handles 1.00
 No. 1729—Yarn, Tight Wound, 1 1/2" Balls, Stiff Cane Handles 1.50
 No. 1730—Yarn, Tight Wound, 1 3/4" Balls, Stiff Cane Handles 2.00
 No. 1731—Yarn, Tight Wound, 2" Balls, Stiff Cane Handles 2.00

PAGE 97

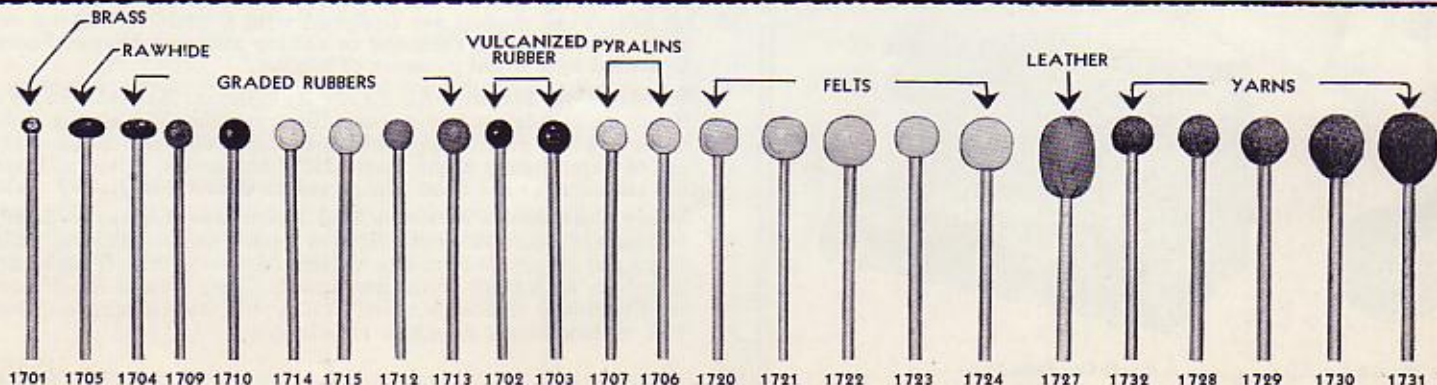

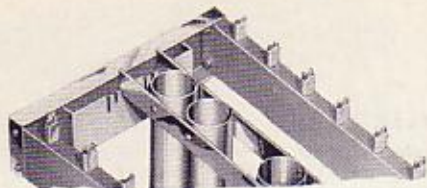

Resonator Adjusting Device



Split Frames and Resonators



Sturdy, Rigid Stand



New Wheel Brakes

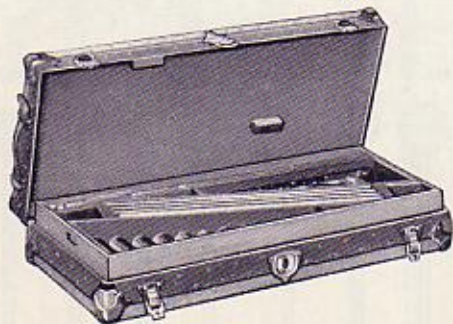

Leedy Own Make Trunks

NOTEWORTHY FEATURES OF SOLO-TONE MARIMBAS AND XYLOPHONES

Resonator Adjusting Device—Extreme temperatures affect the musical pitch of wood and metal in exactly the opposite directions. Excessive heat causes the tone of all wood bars to become somewhat flat and the metal resonators to become somewhat sharp. Excessive cold acts just the reverse. Therefore, in order to obtain the maximum volume of tone from each bar, under all temperature conditions, it is necessary to regulate the distance between the under side of the bars and the mouth of the resonators. In other words, we must place the air chamber in the resonators in exact "sympathy" with the bars so that both will vibrate in perfect unison. The Leedy Resonator Adjusting Device accomplishes this result. There are three sets of "step slots" in the frame at the bass end of all models except the Feather-Wate Xylophone. Place resonators in the center slot when temperature is from 75 to 85 degrees; place in upper slot when temperature is above 85 degrees, and place in lower slot when temperature is below 75 degrees.

Split Frames and Resonators—This feature prevents these parts from sagging. Built on the cantilever principle. The frames and resonators "break" in the middle by simply lifting apart. No thumb screws or bolts are used.

New Wheel Brakes—The two wheels nearest the performer on all Solo-Tone models are equipped with a positive braking device. This prevents creeping or rolling away on uneven floors. Operated by a slight pressure of the toe.

Sturdy, Rigid Stands—All Leedy Xylophone, Marimba and Vibraphone stands are as rigid as a library table. The stands come apart in a few pieces and the long center brace telescopes. Legs are of extra heavy angle steel. Note the smart, graceful lines. All stands are chromium plated unless ordered in Nobby Gold.

Leedy Own Make Marimba and Xylophone Trunks—Leedy trunks are positive protection to instruments. Blocks, pads, trays and straps designed to safeguard every part. Trunks are listed on each page with instrument. They cost a little more than ordinary trunks, but are well worth the difference. They will withstand the roughest handling.

SOLO-TONE GRAND MARIMBA-XYLOPHONE

ALL DISCORDANT OVERTONES ELIMINATED BY THE LEEDY PATENTED PROCESS

BARS 2½" by 1¾" by ⅜"

- SPLIT FRAMES AND RESONATORS
- RESONATOR ADJUSTER FOR TEMPERATURE
- SUSPENSION MOUNTING OF BARS
- BRASS RESONATORS WITH CAPS
- RUBBER-TIRED WHEELS WITH BRAKES

FINISHED WITH

- BLACK PEARL ON WOOD FRAMES
- CHROMIUM PLATED RESONATORS, STAND, ETC.

No. 5605—4½ Octaves, F-33 to C-88, 56
 Bars 2½" to 1¾" Wide by
 ⅞" Thick. Length 78". Width
 Lower End 34". Height 34".
 Weight 120 Lbs. \$340.00

No. 5606—5 Octaves, C-28 to C-88, 61
 Bars 2½" to 1¾" Wide by
 ⅞" Thick. Length 87". Width
 Lower End 37". Height 34".
 Weight 134 Lbs. \$390.00

5 Pair Assorted Mallets Included

Following Finishes On Special Order--10 Days Required

Choice of "Full Dress" Pearl, Sparkling or Duco Finishes
 on Wood Frames--No Extra Charge

Nobby Gold on Resonators, Stand Etc.--\$25.00 Extra

TRUNKS

Made of strong 3-ply Basswood with vulcanized fibre inside and out. Designed and reinforced to safeguard the instrument 100%.

‡No. 6950—1 Trunk for 4½ Oct. Grand \$ 85.00

‡No. 6951—2 Trunks for 5 Oct. Grand .. 165.00

This Marimba-Xylophone has emphatically proven itself to be the most popular instrument of its size and type ever presented for professional use. The only difference between this and the Monarch model is in the size of the bars and resonators. The bars are of genuine Honduras Rosewood mounted on the Leedy system of suspension mounting, which permits them to be lifted from the frames without disengaging the cord. Fine quality of tone, with volume and carrying power in every bar to a maximum degree. These qualities combined with the Leedy patented process of tuning, which eliminates all discordant overtones, and the effective resonator adjusting device assure the performer of several outstanding features found in no other make of instrument. The usual superior quality of workmanship and materials is guaranteed. Tuned to A-440 unless ordered otherwise.

YOUR CHOICE OF ELEVATED OR LEVEL MOUNTING OF THE SHARPS AND FLATS

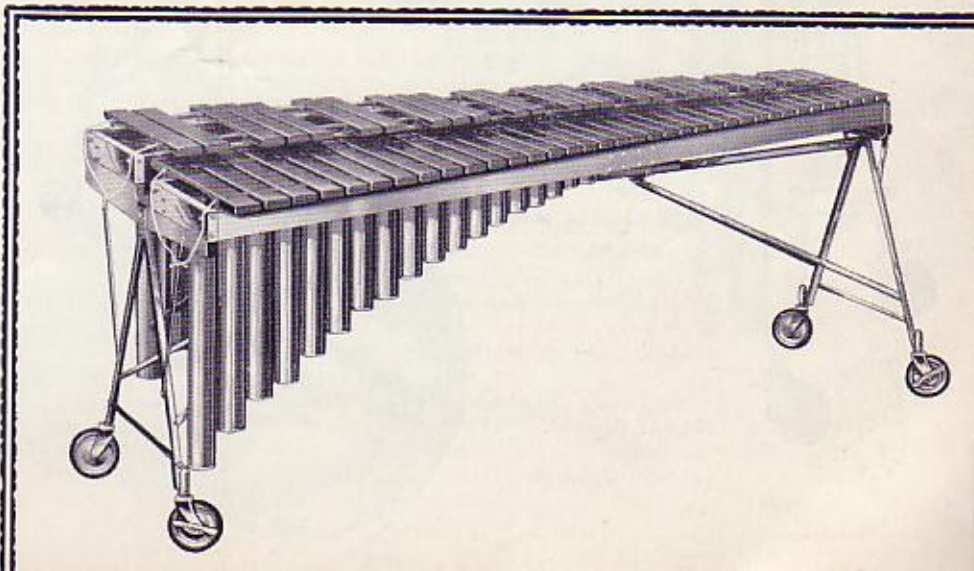

SOLO-TONE STRAIGHT MARIMBA

ALL DISCORDANT OVERTONES ELIMINATED BY THE LEEDY PATENTED PROCESS

The Solo-Tone Marimba has a powerful, rich, mellow, sustained tonal quality that is similar to that of the organ, especially in the lower range. It also has the same split resonator and stand features of the Monarch and Grand Marimba-Xylophones. Honduras Rosewood bars used throughout and tuned by the Leedy patented process which eliminates all discordant overtones. The metal crotchets, over which the cord supporting the bars is drawn, are rubber insulated. The cords, after being drawn tightly, suspend the bars in mid-air and are securely held by a unique spring clamping device. The resonators may be adjusted to meet all atmospheric conditions. The entire instrument is constructed to the usual high Leedy standards and is guaranteed in every respect. Tuned to A-440 pitch unless ordered otherwise.

YOUR CHOICE OF ELEVATED OR LEVEL MOUNTING OF THE SHARPS AND FLATS

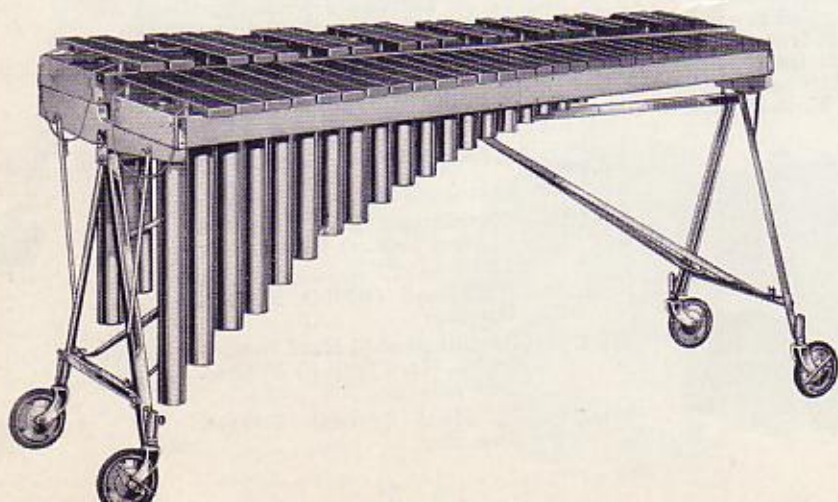

BARS 2½" to 1¾" by ¾"
SPLIT FRAMES AND RESONATORS
RESONATOR ADJUSTER FOR TEMPERATURE
BRASS RESONATORS WITH CAPS
SUSPENSION MOUNTING OF BARS
RUBBER-TIRED WHEELS WITH BRAKES

FINISHED WITH
BLACK PEARL ON WOOD FRAMES
CHROMIUM PLATED STAND WITH RESONATORS

- No. 5610—3½ Octaves, F-33 to C-76, 44 Bars 2¼" to 1¾" Wide by 7/8" Thick. Length 62". Width Lower End 32". Height 34". Weight 100 Lbs. \$225.00
- No. 5611—4 Octaves, C-28 to C-76, 49 Bars 2½" to 1¾" Wide by 7/8" Thick. Length 71". Width Lower End 35". Height 34". Weight 115 Lbs. 275.00

5 Pair Assorted Mallets Included

Following Finishes On Special Order--10 Days Required

Choice of Other "Full Dress" Pearl, Sparkling or Duco

Finishes on Wood Frames--No Extra Charge

Nobby Gold on Resonators, Stand, Etc., \$25.00 Extra

TRUNKS

Made to safeguard the instrument 100%. Constructed of 3-ply Basswood, lined and covered with vulcanized fibre and strongly reinforced.

‡No. 6955—1 Trunk for 3½ Oct. Marimba \$80.00

‡No. 6956—1 Trunk for 4 Oct. Marimba. 85.00

new

THE WORLD'S FINEST

Leedy

THE SENSATIONAL SOLO-TONE OCTARIMBA

LEEDY CREATES A NEW WOOD-BAR INSTRUMENT
WHOSE TONAL BEAUTY AND VOLUME ARE UNMATCHED

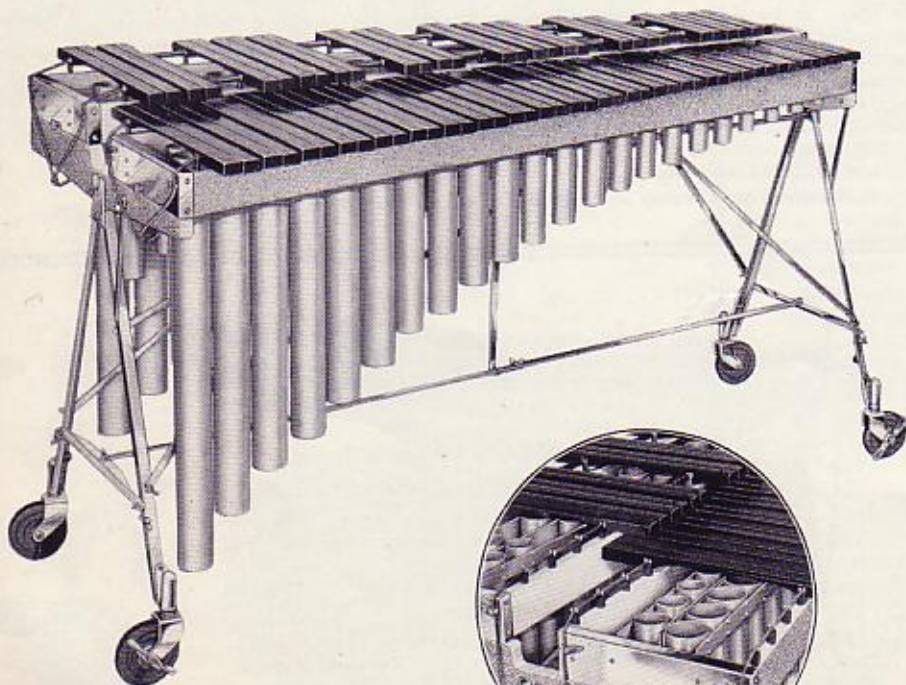

The Octarimba has the most fascinating and beautiful tone of all the wood-bar instruments, which makes possible an entirely new and richer musical expression, with tone coloring never heard before. This is because the full, resonant speaking voice of the marimba is now *actually combined* with the higher and more brilliant timbre of the xylophone *in the same playing octave*. Never before has there been a wood-bar instrument to equal the Octarimba's sympathetic response, or its latitude of expression.

The essential difference between the Octarimba and other wood-bar instruments, as well as the basic reason for its remarkable new qualities, lies in the fact that *each playing note of the Octarimba is composed of two bars of the same size tuned an octave apart*, and which are struck simultaneously with specially designed double-headed forked mallets. Thus, the lowest double bar of the Octarimba is a combination of the C-28 and C-40 tones of the piano, the C-28 being the lowest note of our largest (the 5-octave) marimba (see chart on page 89). In other words, two bars act as one, as far as playing is concerned, to give a 1-octave tonal range when only one note is struck. With this set-up, the lower three octaves of our 5-octave marimba and the lower three octaves of our 4-octave xylophone are combined into one instrument with a 3-octave playing range and a 4-octave sounding range.

The Octarimba has 74 bars instead of 37 as found on the usual 3-octave wood-bar instruments, and there is an individual resonator under each bar, properly designed to give the best tone and maximum volume.

OFFERS REMARKABLE MUSICAL ADVANTAGES

74 BARS $1\frac{1}{2}'' \times \frac{3}{4}''$
SPLIT FRAMES AND RESONATORS
RESONATOR ADJUSTMENT FOR TEMPERATURE
SUSPENSION MOUNTING OF BARS
SATIN FINISH ALUMINUM RESONATORS
RUBBER COMPOSITION WHEELS, WITH BRAKES

FINISHED WITH
SPARKLING SILVER ON WOOD FRAMES
CHROMIUM PLATED STAND

Bars of genuine Honduras Rosewood tuned by the exclusive Leedy patented process which eliminates all discordant overtones, and mounted on suspension cord to permit free, full tone. Sparkling Silver Pyralin on the wood frames; split aluminum resonators in satin finish, which are adjustable to meet atmospheric conditions. Strong, rigid stand, Chromium plated and highly polished, and two of the rubber composition wheels are equipped with brakes which are operated by the foot.

No. 5602—3 Octaves, combined C-28 and C-40 to combined C-64 and C-76, 74 Bars $1-3/32''$ Wide by $3/4''$ Thick. Length 61". Width at Lower End 31". Height 34". Weight 82 lbs. \$240.00

5 Pair Assorted Octarimba Mallets Included
 Following Finishes on Special Order—10 Days
 Required for Delivery

Choice of Other "Full Dress" Pearl, Sparkling Pyralin or
 Duco Finishes on Wood Frames—No Extra Charge
 Nobby Gold on Resonators, Stand, Etc.—\$25.00 Extra

†No. 6974—3 Vulcanized Fibre Hand
 Carrying Cases for the
 Octarimba \$60.00
 ‡No. 6959—Octarimba Trunk Made
 Specially to Order 75.00



Only two mallets are used on this instrument to get the splendid tonal effects and unusual volume that cannot be gotten on other wood-bar instruments even with four or more hammers. There is nothing new to learn about playing the Octarimba: anyone who plays the regular Xylophone, Marimba or Bells will find it a "snap" by comparison. Five pairs of selected Octarimba mallets of graded rubbers, and combinations of graded rubbers, for different volumes and tonal effects, are supplied with each instrument. These mallets are made of stripped, flexible rattan forked at one end and strongly reinforced. Heads are cylinder-shaped, with the flat ends slightly beveled as illustrated above and listed below.

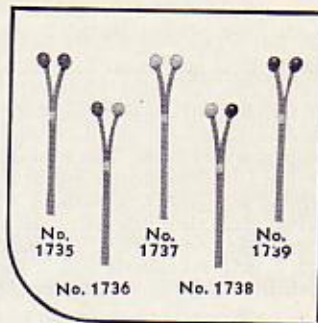

The Octarimba can be set up for playing (or knocked down for packing) as quickly and as easily as the conventional xylophone or marimba. The stands and frames include all the exclusive features of the finest Leedy Solo-Tone instruments. The entire instrument packs into three convenient, strongly reinforced, vulcanized fibre hand carrying cases which are fully blocked, padded and partitioned. Weight packed 128 lbs.

OCTARIMBA MALLETS

No. 1735—Soft (red) Rubber. Per pair \$2.00
 No. 1736—Combination Soft (red) and
 $\frac{1}{2}$ Hard (white) Rubber. Per
 pair 2.00
 No. 1737—Half-Hard (white) Rubber.
 Per pair 2.00
 No. 1738—Combination $\frac{1}{2}$ Hard (white)
 and $\frac{3}{4}$ Hard (green) Rubber.
 Per pair 2.00
 No. 1739— $\frac{3}{4}$ Hard (green) Rubber.
 Per pair 2.00

SOLO-TONE STANDARD XYLOPHONE

ALL DISCORDANT OVERTONES ELIMINATED BY THE LEEDY PATENTED PROCESS

The general design and construction of Leedy Solo-Tone Standard Xylophones is identically the same as that of the Marimbas . . . the only difference is in the size of the bars and resonators. They naturally have to be built in other proportions because the character of the Xylophone demands a brilliant, staccato, powerful tone. The Leedy Solo-Tone Standard Xylophone has all of these features, with "richness" and "body" added. The bars are made of genuine Honduras Rosewood, accurately tuned, and suspension mounting is employed in the same manner as on our Marimbas. They may be lifted free of the frames without disengaging the cords from the bars. The stand is the strongest and most rigid xylophone stand made. Rubber tired wheels, with brakes, are also included. Tuned to A-440 pitch unless ordered otherwise. Bar sizes, other specifications and finishes are shown at the right.



BARS 1 3/4" by 7/8"

SPLIT FRAMES AND RESONATORS
 RESONATOR ADJUSTER FOR TEMPERATURE
 SUSPENSION MOUNTING OF BARS
 BRASS RESONATORS WITH CAPS
 RUBBER-TIRED WHEELS WITH BRAKES

FINISHED WITH

BLACK PEARL ON WOOD FRAMES
 CHROMIUM PLATED STAND AND RESONATORS

- No. 5615—3 1/2 Octaves, G-47 to C-88, 42
 Bars 1 3/4" Wide by 7/8" Thick.
 Length 57". Width Lower
 End 28". Height 34". Weight
 66 Lbs. \$195.00
- No. 5616—4 Octaves, C-40 to C-88, 49
 Bars 1 3/4" Wide by 7/8" Thick.
 Length 65". Width Lower
 End 31". Height 34". Weight
 82 Lbs. \$210.00
- 4 Pair Assorted Mallets Included

* Following Finishes On Special Order--10 Days Required
 Choice of Other "Full Dress" Pearls, Sparkling or Duco
 Finishes on Wood Frames--No Extra Charge

† [Nobby Gold on Resonators, Stand, Etc.--\$25.00 Extra

TRUNKS

- Built to give the instrument the fullest protection possible. Made of 3-ply Basswood and vulcanized fibre and strongly reinforced.
- ‡No. 6960—1 Trunk for 3 1/2 Oct. Xylophone \$70.00
- ‡No. 6961—1 Trunk for 4 Oct. Xylophone 75.00

SOLO-TONE MELLORIMBA

ALL DISCORDANT OVERTONES ELIMINATED BY THE LEEDY PATENTED PROCESS

BARS 2" to 1½" by ¾"
 SPLIT FRAMES AND RESONATORS
 RESONATOR ADJUSTER FOR TEMPERATURE
 SUSPENSION MOUNTING OF BARS
 POLISHED ALUMINUM RESONATORS
 RUBBER-TIRED WHEELS WITH BRAKES

FINISHED WITH

BLACK PEARL ON WOOD FRAMES
 CHROMIUM PLATED STAND AND RESONATORS

No. 5613—3½ Octaves, F-33 to C-76, 44
 Bars 2" to 1½" Wide by ¾"
 Thick. Length 57". Width
 Lower End 31". Height With
 Wheels for Standing Posi-
 tion 34"; Without Wheels for
 Sitting Position 27". Weight
 72 Lbs. In Cases 80 Lbs. ... \$195.00
 4 Pair Assorted Mallets Included

Following Finishes On Special Order--10 Days Required

Choice of Other "Full Dress" Pearl, Sparkling or Duco
 Finishes on Wood Frames--No Extra Charge

Nobby Gold on Resonators, Stand, Etc.--\$25.00 Extra

CARRYING CASES

Cases are made of vulcanized black fibre, strongly riveted and equipped with sturdy handle and full leather straps. Each case carefully partitioned. An instrument worth owning is worth the protection that this Leedy own make Carrying Case will give.

†No. 6963—2 Hand-Carrying Cases for
 Mellorimba \$40.00

The new Solo-Tone Mellorimba is a comparatively recent addition to the Leedy mallet-played instrument family. To say that it "went over in a big way" from the very start is putting it mildly. It found immediate favor because it has a beautiful and true Marimba quality of tone, plus easy-carrying features—a combination long desired by the jobbing professional. Here is an instrument that has plenty of volume and carrying power for the largest halls, yet weighs only 80 lbs, packed in two fibre hand-carrying cases. For quick set-up and take-down, quality materials, workmanship and appearance it has no equal at anywhere near the same price. Will stand the hard usage that jobbing imposes on instruments of this type. Blocks and straps built on the inside of the cases protect every part. Ask your nearest Leedy dealer to show you the Mellorimba. You will like it. Tuned to A-440 pitch unless ordered otherwise.

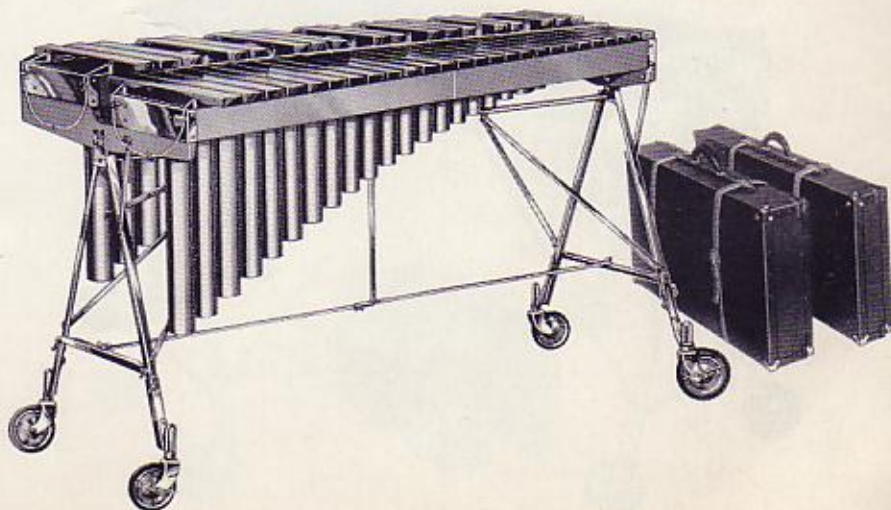

SOLO-TONE STANDARD XYLOPHONE

ALL DISCORDANT OVERTONES ELIMINATED BY THE LEEDY PATENTED PROCESS

The general design and construction of Leedy Solo-Tone Standard Xylophones is identically the same as that of the Marimbas . . . the only difference is in the size of the bars and resonators. They naturally have to be built in other proportions because the character of the Xylophone demands a brilliant, staccato, powerful tone. The Leedy Solo-Tone Standard Xylophone has all of these features, with "richness" and "body" added. The bars are made of genuine Honduras Rosewood, accurately tuned, and suspension mounting is employed in the same manner as on our Marimbas. They may be lifted free of the frames without disengaging the cords from the bars. The stand is the strongest and most rigid xylophone stand made. Rubber tired wheels, with brakes, are also included. Tuned to A-440 pitch unless ordered otherwise. Bar sizes, other specifications and finishes are shown at the right.

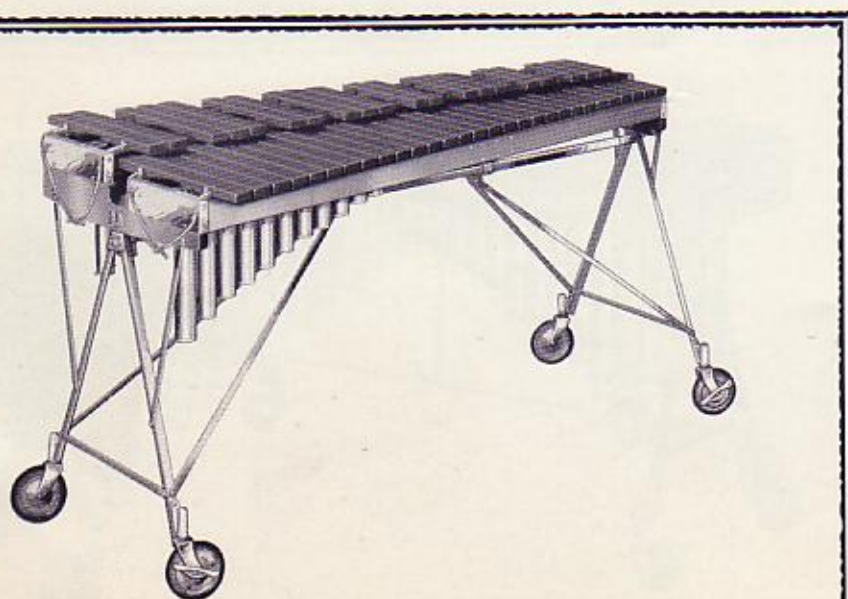

BARS 1 3/4" by 3/8"

SPLIT FRAMES AND RESONATORS
 RESONATOR ADJUSTER FOR TEMPERATURE
 SUSPENSION MOUNTING OF BARS
 BRASS RESONATORS WITH CAPS
 RUBBER-TIRED WHEELS WITH BRAKES

FINISHED WITH
 BLACK PEARL ON WOOD FRAMES
 CHROMIUM PLATED STAND AND RESONATORS

- No. 5615—3 1/2 Octaves, G-47 to C-88, 42
 Bars 1 3/4" Wide by 7/8" Thick.
 Length 57". Width Lower
 End 28". Height 34". Weight
 66 Lbs. \$195.00
- No. 5616—4 Octaves, C-40 to C-88, 49
 Bars 1 3/4" Wide by 7/8" Thick.
 Length 65". Width Lower
 End 31". Height 34". Weight
 82 Lbs. \$210.00

4 Pair Assorted Mallets Included

- * Following Finishes On Special Order--10 Days Required
 Choice of Other "Full Dress" Pearls, Sparkling or Duco
 Finishes on Wood Frames--No Extra Charge
- † [Nobby Gold on Resonators, Stand, Etc.--\$25.00 Extra

TRUNKS

- Built to give the instrument the fullest protection possible. Made of 3-ply Basswood and vulcanized fibre and strongly reinforced.
- ‡No. 6960—1 Trunk for 3 1/2 Oct. Xylophone \$70.00
- §No. 6961—1 Trunk for 4 Oct. Xylophone 75.00

SOLO-TONE BROADCASTER XYLOPHONE

ALL DISCORDANT OVERTONES ELIMINATED BY THE LEEDY PATENTED PROCESS

BARS 1½" by ¾"

- SPLIT FRAMES AND RESONATORS**
- RESONATOR ADJUSTER FOR TEMPERATURE**
- SUSPENSION MOUNTING OF BARS**
- BRASS RESONATORS WITH CAPS**
- RUBBER-TIRED WHEELS WITH BRAKES**

FINISHED WITH

- BLACK PEARL ON WOOD FRAMES**
- CHROMIUM PLATED STAND AND RESONATORS**

No. 5620—3½ Octaves, F-45 to C-88, 44 Bars 1½" Wide by ¾" Thick. Length 52". Width Lower End 28". Height 34". Weight 72 Lbs. \$175.00

No. 5621—4 Octaves, C-40 to C-88, 49 Bars 1¾" to 1½" Wide by ¾" Thick. Length 59". Width Lower End 31". Height 34". Weight 83 Lbs. \$190.00

4 Pair Assorted Mallets Included

Following Finishes On Special Order--10 Days Required

Choice of Other "Full Dress" Pearl, Sparkling or Duco Finishes on Wood Frames--No Extra Charge

Nobby Gold on Resonators, Stand, Etc.--\$25.00 Extra

CASES AND TRUNKS

†No. 6965—2 Cases for 3½ Oct. Size \$35.00
Weight Packed: Large Case 52 Lbs.; Small Case 47 Lbs.

†No. 6966—2 Cases for 4 Oct. Size \$40.00
Weight Packed: Large Case 58 Lbs.; Small Case 53 Lbs.

†No. 6970—1 Trunk for 3½ Oct. Size \$65.00

†No. 6971—1 Trunk for 4 Oct. Size 70.00

Here is the Xylophone that nearly five thousand professional, school and home xylophone players have adopted as the instrument best suited for general all-around use. Its marvelously rich and brilliant tone, combined with the fact that it is easy and quick to set up and take down, has made it the leader by a wide margin. It solves every transportation problem—note below weights as packed in cases. This instrument is the successful outcome of the requirements laid down by leading professional drummers in every branch of the profession; a xylophone that is smaller than our Standard model, but one with corresponding quality and tone and with volume sufficient to fill the largest auditorium—an instrument of true professional qualifications made to meet every professional need. Tuned to low (A-440) pitch unless ordered otherwise. A wonderful jobbing instrument for dance and radio work at a moderate price.

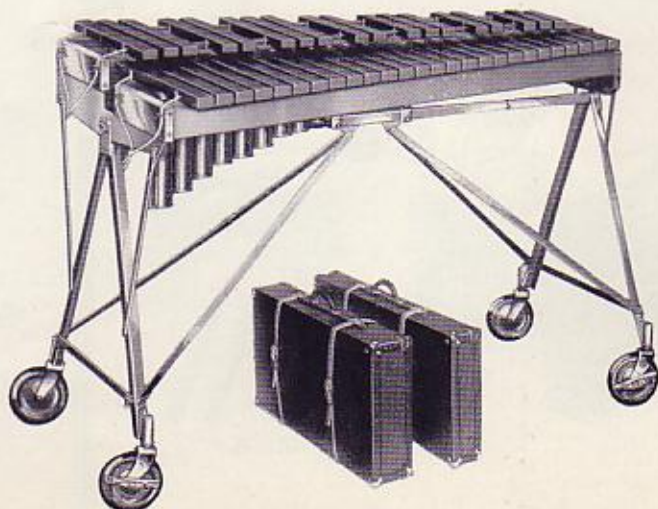



No. 5612



No. 8148



No. 6973



No. 8145

THE NEW ZYRIMBA

This is the smallest and lightest Marimba-Xylophone in the present Leedy line and is designed for the jobbing drummer who wants the resonance of the Marimba with the sparkling tone of the Xylophone combined in one instrument. Its exceptional tone and volume make it an excellent instrument for general all-around use, and its low price places it within reach of almost everyone. Ideal for the school band and orchestra. The stand is rigid, strong, and easy to set up or take down. Entire instrument fits conveniently into one fibre hand-carrying case which weighs only 62 lbs. packed. The Zyrimba is made and listed so that extension legs or wheels may be purchased separately.

BARS $1\frac{3}{4}$ " to $1\frac{1}{2}$ " by $\frac{3}{8}$ "
1-PIECE FRAMES AND RESONATORS
RESONATOR ADJUSTER FOR TEMPERATURE
SUSPENSION MOUNTING OF BARS

FINISHED WITH
SILVER DUCO WOOD FRAMES
CHROMIUM PLATED STAND AND METAL PARTS
POLISHED ALUMINUM RESONATORS

No. 5612—3 Octaves, C-40 to C-76, 37 Bars $1\frac{3}{4}$ " to $1\frac{1}{8}$ "
 Wide by $\frac{3}{4}$ " Thick. Length 44". Width at
 Lower End 28". Height 25". Weight 40 Lbs. \$125.00

4 Pair Assorted Mallets Included

Following Finishes On Special Order—10 Days Required
 Black or White Duco Wood Frames—No Extra Charge
 Choice of Other "Full Dress" Pearls or Sparkling Finishes on
 Wood Frames—\$8.00 Extra

Nobby Gold on Resonators, Stand, Etc.—\$25.00 Extra

No. 8148—Four Rubber-Tired Wheels (Two with
 Brakes) \$15.00 Extra
 No. 8145—Extension Legs Only 3.50 Extra

CARRYING CASE AND TRUNK

Strongly made of the best grade materials for the fullest protection of the instrument. Will stand the gaff.

†No. 6973—1 Fibre Hand-Carrying Case for Zyrimba ... \$22.50
 †No. 6958—1 Trunk for Zyrimba 60.00

SPECIAL UTILITY XYLOPHONE

This small, light Xylophone is constructed along the same lines as the larger Solo-Tone models, but the general dimensions have been reduced to meet the needs of the drummer who must have a professional quality instrument that is small enough to take with him on every job, or who must crowd into a small theatre pit or on a narrow dance platform. This Xylophone has a brilliant, rich tone, with surprising volume and carrying power. It has a rigid, fast-folding stand, and is supplied with wheels for playing in a standing position; or without the wheels. A splendid instrument for dance jobbing or use in the school.

BARS 1½" by ¾"
1-PIECE FRAMES AND RESONATORS
SUSPENSION MOUNTING OF BARS

FINISHED WITH
SILVER DUCO WOOD FRAMES
CHROMIUM PLATED STAND AND METAL PARTS
POLISHED ALUMINIUM RESONATORS

No. 5624—3 Octaves, C-52 to C-88, 37 Bars 1½" Wide by ¾" Thick. Length 44". Width at Lower End 25". Height With Extension Legs 33"; Without Extension Legs 25". Weight 45 Lbs. \$110.00

4 Pair Assorted Mallets Included
 Following Finishes On Special Order—10 Days Required
 Black or White Duco Wood Frames—No Extra Charge
 Choice of Other "Full Dress" Pearls or Sparkling Finishes on Wood Frames—\$8.00 Extra
 Nobby Gold on Resonators, Stand Etc.—\$25.00 Extra

No. 8148—Four Rubber-Tired Wheels (Two With Brakes) \$15.00 Extra
 †No. 6976—Fibre Hand-Carrying Case \$20.00

XYLOPHONE AND MARIMBA MALLET HOLDER

A handy little device for holding your mallets, and which can be attached to any instrument without marring its appearance.

No. 1980—Nickel \$1.00 No. 1982—Chromium \$1.50
 No. 1981—Nobby Gold \$1.50



No. 5624

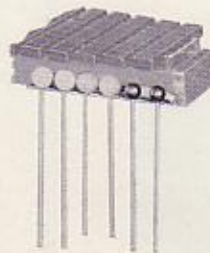

No. 1980



No. 6976

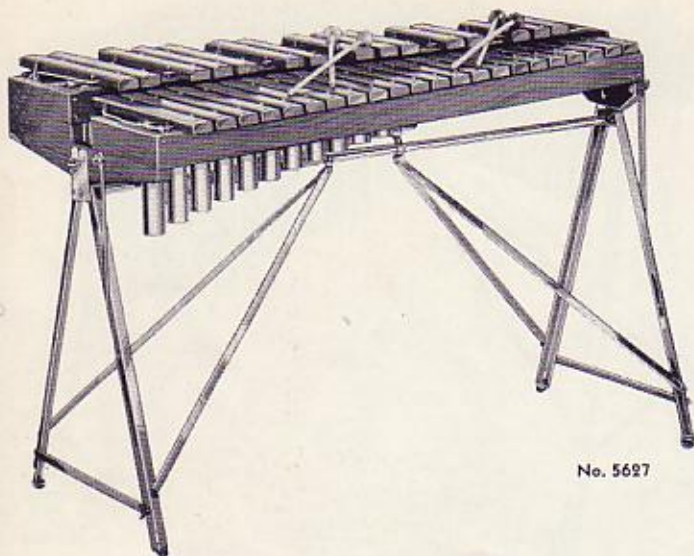

No. 5627



Extension Legs Included



No. 6977

FEATHER-WATE XYLOPHONE

This is the smallest and lightest of the resonator type Xylophones in the Leedy line. However, its size and light weight have not in the slightest degree interfered with its practicability. Naturally, these smaller bars do not produce as great a volume of tone as do the larger bars on the larger instruments, but they do produce the same brilliance and rich quality, due to the fact that only the best Honduras Rosewood is used and the same careful workmanship and tuning are employed. This model was designed for the drummer who wants a genuine Xylophone of extremely light weight for jobbing purposes, also to fit in small theatre pits, crowded dance platforms and for the school band and orchestra that cannot purchase one of the higher priced models at the start. The rigid, chromium plated stand may be used without the extension legs for sitting position, or with the extension legs for playing while standing.

BARS 1 $\frac{1}{4}$ " by $\frac{5}{8}$ "

1-PIECE FRAMES AND RESONATORS
SUSPENSION MOUNTING OF BARS
EXTENSION LEGS

FINISHED WITH
NATURAL FINISH MAHOGANY WOOD FRAMES
CHROMIUM PLATED STAND AND METAL PARTS
POLISHED ALUMINUM RESONATORS

No. 5627—3 Octaves, C-52 to C-88, 37 Bars 1 $\frac{1}{4}$ " Wide by $\frac{5}{8}$ " Thick. Length 36". Width at Lower End 22". Height With Extension Legs 33"; Without Extension Legs 25". Weight 23 Lbs.\$75.00

2 Pair Selected Mallets Included

CARRYING CASE

Made of the best grade black vulcanized fibre with blocks, pads and leather straps for holding instrument firmly in place. Weighs only 33 lbs. packed.

†No. 6977—Fibre Hand-Carrying Case\$10.00

CASE XYLOPHONE

Bars are made of the same high grade genuine Honduras Rosewood as used on all Leedy Xylophones. They rest on a cushion of triangular-shaped hard felt and are mounted in a strong fabrikoid (folding bell model) hand-carrying case. Bars are protected at all times because of the case. This Xylophone is a dandy jobbing instrument, with great brilliance of tone and ample carrying power. Weighs 18 Lbs. complete.

No. 5635—2½ Octaves, G-59 to C-88, 30 Bars 1½" Wide
by ¾" Thick \$35.00

XYLOPHONETTE

Here we present practically the same instrument as the Case Xylophone shown above—without the case and with slightly smaller bars. It is manufactured along the same lines in regard to workmanship and tuning as the higher priced Leedy Xylophones, with quality materials used throughout, including Honduras Rosewood. Complete frames for mounting included.

No. 5640—2½ Octaves, G-59 to C-88, 30 Bars 1¼" Wide
by ¾" Thick \$18.00

No. 5641—3 Octaves, C-52 to C-88, 37 Bars 1¼" Wide by
¾" Thick 21.50

REAL-LIGHT XYLOPHONE

This fine little Xylophone is offered at a lesser price only because of the smaller bars and single frame. Especially designed for school use and in no sense a toy. Honduras Rosewood bars are accurately tuned and are brilliant in tone.

No. 5645—2½ Octaves, G-59 to C-88, 30 Bars, 1⅛" Wide
by ⅝" Thick \$14.00

†No. 6937—Fabrikoid Carrying Case 7.00

LIGHT-WEIGHT FOLDING XYLOPHONE STAND

A strong, serviceable xylophone stand for the Case Xylophone, the Xylophonette and the Real-Light Xylophone. Also a fine bell stand and will hold all case models. Folds into small space. Makes an excellent trap table by placing a piece of 3-ply wood or beaver board across the top.

No. 7280—Nickel \$6.00

The Special Chart on Page 89 Shows the Relationship of All Leedy Mallet-Played Instruments to the Standard 88-Note Piano Keyboard



No. 5635



No. 5640

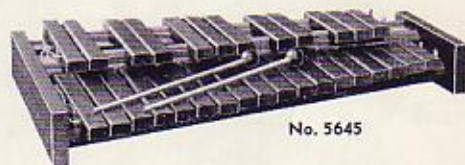

No. 5645



No. 7280

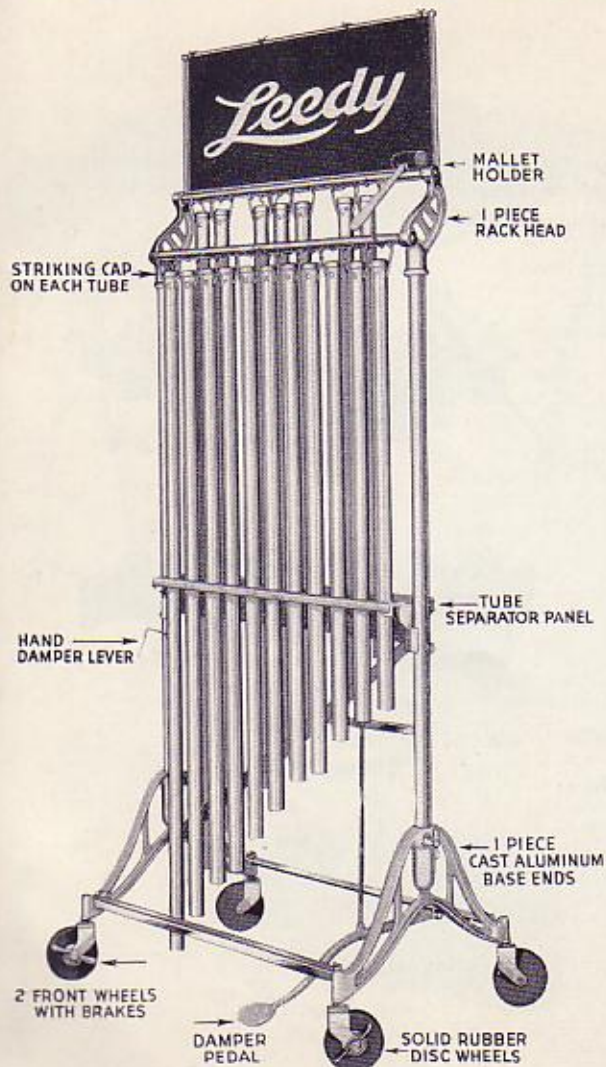

No. 5708

NEW ELEVATED DAMPER CHIMES

Leedy is proud to present the new and still more improved Elevated Damper Chimes—one of the outstanding and most important items in our entire mallet-played instrument line. No musical organization can ask for chimes with finer tonal qualities, greater playing flexibility, more perfect construction or more impressive appearance, than these.

The new damper, now an integral part of the chimes, has been built into the instrument in such a way that the player can now mute the tubes to any desired degree, either by using a *pedal* or a *lever* operated by the left hand. With these features it is now possible and practical to play rapid passages and "hot stuff" whenever the occasion demands as simply and as easily as playing bells with one mallet.

The new damper, together with the elevated tube mounting, has increased the musical scope of chimes more than 100% by permitting playing with either one or both hands. The chime cap feature, originated by Leedy, assures evenness of tone, and is standard on all models.

CATHEDRAL MODEL—1½" TUBES

1½ Octaves—18 Tubes—Chromium Plated—C-52 to F-69, A-440 Pitch

No. 5708—Complete With Damper and Wheels \$295.00

(NOT SUPPLIED WITHOUT DAMPER AND WHEELS)

Above Chimes in Nobby Gold—\$25.00 Extra

Trunk for Cathedral 1½" Chimes †No. 6980 \$100.00

Banner Rack for Cathedral 1½" Chimes No. 8205 5.00

Velvet Banner (With Orchestra's Name) No. 8215 5.50

ORCHESTRA MODEL—1" TUBES

1½ Octaves—18 Tubes—Chromium Plated—C-52 to F-69, A-440 Pitch

No. 5711—Complete With Damper and Wheels \$165.00

(NOT SUPPLIED WITHOUT DAMPER AND WHEELS)

Above Chimes in Nobby Gold—\$25.00 Extra

Fibre Hand Carrying Case for No. 5711 †No. 6986 \$20.00

Trunk for Orchestra 1" Chimes †No. 6981 65.00

Banner Rack for Orchestra 1" Chimes No. 8206 4.00

Velvet Banner (With Orchestra's Name) No. 8216 4.50

ORCHESTRA MODEL—1" TUBES—(NOT ILLUSTRATED)

1½ Octaves—18 Tubes—Chromium Plated—C-52 to F-69, A-440 Pitch

No. 5712—Without Damper and Wheels \$140.00

Above Chimes in Nobby Gold—\$25.00 Extra

(Fibre Case, Trunk, Banner Rack and Banner for No. 5712 are same as for No. 5711. Use catalog numbers and prices as shown under No. 5711).

ABOUT THE "STRIKING-CAPS" ON ALL LEEDY CHIMES

All Leedy Chime Tubes have heavy bell metal "striking-caps" which act as a correct contact surface for the mallets. They assure evenness of tone quality and eliminate all possibilities of a half-volume "ping" tone on one note and a full tone on the next. These caps are an original Leedy creation which has since been adopted by other makers. In addition to their merit from a musical standpoint, they also add greatly to the appearance of the instrument.



EXTRA CHIME TUBES

All Leedy Chime Tubes are made of drawn seamless, specially alloyed tubing. They are noted for their depth and richness of tone, with great volume and carrying power. The tuning is positively guaranteed to be accurate.

State Note, or Notes, Desired When Ordering

No. 5685—1½" Chime Tube—Chromium. Each	\$10.00
No. 5686—1½" Chime Tube—Nobby Gold. Each	11.00
No. 5687—1" Chime Tube—Chromium. Each	6.00
No. 5688—1" Chime Tube—Nobby Gold. Each	7.00

ORCHESTRA BELL REPAIR ITEMS

No. 1956—Felt Mounting for Bells—State Model— Four Strips	\$1.20
No. 1957—Felt Washers for Bell Pins—State Model —Set of 75	1.00
No. 1958—Bell Pins With Felt Washers—State Model—Set of 75	1.20

XYLOPHONE REPAIR ITEMS

No. 1961—Mounting Cord—State Model. Per Foot.....	\$.04
No. 1962—Felt Washers—State Model—Per Dozen.....	.25
No. 1963—Felt Washers—State Model. Per 100	1.00
No. 1964—Xylophone Rubber Separators for Sharps and Flats. State Model. Each05
No. 1965—Xylophone Rubber Tube Covers for Metal Crotchets. State Model. Each02

REPLACEMENT BARS FOR XYLOPHONES AND MARIMBAS

Prices on new Xylophone and Marimba bars for replacement purposes will be quoted on request. Write fully, stating the name of the instrument, the catalog number and the note, or notes, desired (designating same by *note* and *number* as indicated by the Compass Chart of Leedy Mallet-Played Instruments on page 89 of this catalog). It is also best to give us the length from center to center of the cord holes. A tracing of the old bar indicating all of the above assures better and faster service. Individual bars or complete sets can be supplied from this information.

RETUNING BARS FOR XYLOPHONES, MARIMBAS AND BELLS

Prices for retuning Xylophone, Marimba and Bell bars can be quoted only if the bars are sent to the factory for our inspection, due to the fact that the time required for this type of work depends largely on the condition of the bars themselves. Correct retuning necessitates scientific accuracy and great skill. We are equipped to serve you most satisfactorily in these respects. A Leedy instrument can be reconditioned best by our own experienced workmen. It is always necessary to retune bell bars after replating. Prices quoted only after examination of the bars.

REFINISHING XYLOPHONE AND MARIMBA STANDS AND FRAMES

The Leedy factory is naturally fully equipped to handle this type of work most satisfactorily. Estimates on the cost of replating the stands and refinishing the frames will be quoted upon receipt of the parts here at the factory, with a letter stating in detail what is desired.

CHIME MALLETS

Hickory handles with solid, best grade rawhide securely rolled and riveted. Designed to bring out the best tone.



No. 1660

*No. 1660—Large size,
6 oz. weight

*No. 1661—Small size,
4 oz. weight



No. 1661

INDEX TO CATALOG "U"

Anvil	68	Duck Quack	70	Sand Blocks	68
All-in-One Trap	70	Electric Drum Heaters	77	Scotch Bass Drum Sticks	55
Baby Cry	70	Fibre Drum Cases	72-73	Silk Wire Wound Snares	80
Bass Drums, Standard, Spartan, Reliance	33-35	Flesh Hoops	76	Slap Sticks	61
Bass Drum Rack	32	"Full Dress" Drums	10 to 18	Sleigh Bells	67
Bass Drum Head Scenes	53	"Full Dress" Outfits	19 to 22	Slings, Snare and Bass	59
Bass Drum Sticks	25	Gongs, Chinese, and Stand	51	Snares—James, Gut, Silk Wire	80
Bells	94 to 96	Gut Snares	50	Snare Strainers	80
Bell Lyra	96	Harphophone	96	Song Whistle	66
Bell Mallets	97	Heads—Snare, Bass, Tympani	74 to 78	Spu.s. Bass Drum	38 to 41
Bell Plate	69	Heaters, Drum	70	Stands, Bell	95
Bell Stands	96	Hen Cackle	53	Stands, Drum	32
Belt Repair Parts	58	Holder, "Stayon" Drum Stick	61	Stands, Gong	51
Bird Whistle	65	Holder, Triangle	61	Stands, Temple Block	62
Blinker Lights for Bass Drums	23	Holder, Xylophone Mallet	107	Stands, Tom Tom	64-65
Bob White Imitation	70	Holders—Console, Trap Table, Trap Rail	45	"Stayon" Clamp	46
Cases—Drum, Fibre	72-73	Holders, Cow Bell	67	Steamboat Whistle	69
Castanets	60	Holders, Temple Block	62	Sticks, Bass Drum	55
Chimes	110	Holders, Tom Tom	65	Sticks, Hickory, Rosewood, Snakewood	54
Chime Mallets	111	Holders, Wood Block	63	Sticks, Scotch Bass Drum	54
Claves	61	Holders, Hoop Adapter	46	Sticks, Special	55
Counter Hoops	77	Horse Hoofs	68	Sticks, Synco-Jazz	56
Cow Bawl Imitation	70	Imitations	68 to 70	Sticks, Tenor Drum	55
Cow Bells and Holders	67	Inlaid Counter Hoops	77	Sticks, Tympani	88
Cuckoo Imitation	69	Instruction Books	82	Sundries	111
Cyclone Whistle	66	Interchangeable Post Trap Holders	45	Synco-Jazz Brushes	56
Cymbals	47 to 52	James Snares	80	Tambourines	60
Cymbal Beater, Wire	57	Jingle Clogs	63	Temple Blocks and Holders	62
Cymbal Hanger, Strap	50	Key, Snare and Bass Drum	80	Tenor Drum Sticks	55
Cymbal Holders, Drum	47 to 52	Leg Rest—Parade Drum	58	Tom Tom Holders	65
Cymbal Holder, Hand	57	Lights for Bass Drums	23	Tom Tom Stands	64-65
Cymbal Holder, Pedal	38 to 40	Locomotive Imitation	69	Tom Toms, Chinese	65
Cymbal Pedals	52	Locomotive Whistles	69	Tom Toms, Tunable	64
Cymbal Straos and Pads	57	Lyra, Bell	96	Tone Controls, Snare and Bass Drum	53
Drums, "BROADWAY"	3 to 9	Mackintosh Drum Covers	71	Tone Control, Internal Snare Drum	80
Drums, "Full Dress" Snare and Bass	10 to 18	Maracas	61	Trap Board	44
Drums, Junior	31	Marimba Mallets	97	Trap Console	42
Drums, Pep, Nifty	30	Marimbas and Xylophones	98 to 109	Trap Holders, Interchangeable Post	45
Drums, Reliance	28	Musette, Chinese	66	Trap Rail	44
Drums, Utility	29	Music Holder, Parade	58	Trap Table	43
Drum Cases, Fibre	72-73	Nose Blow Imitation	70	Triangles and Holder	61
Drum Covers, Mackintosh	71	Ocarimba	100-101	Trunks, Bass Drum	73
Drum Heads	74 to 78	Ocarimba Mallets and Cases	101	Trunks, Tympani	88
Drum Head Form	77	Outfits, "Full Dress"	19 to 22	Tunable Tom Toms	64
Drum Head Protectors, Fibre	80	Outfits	19 to 27	Tuning Bars	95
Drum Head Tucking	76	Painted Bass Drum Heads	23	Tympani	84-88
Drum Heaters	77	Pedals	38 to 41	Tympani Accessories, Etc.	88
Drum Key	80	Pedal Parts and Balls	40-41	Vibraphones	90 to 93
Drum Repair Parts	80-81	Pop Gun	68	Vibraphone Mallets	97
Drum Slings, Snare and Bass	59	Practice Pads	57	Web Drum Slings	59
Drum Stands	32	Rain Cover	58	Whistles, Locomotive, Steamboat, Cuckoo	69
Drum Sticks, Hickory and Rosewood	54	Refinishing Old Drums	79	Whistles, Song, Cyclone, Bird	66
Drum Sticks, Red End	24	"Red End" Drum Sticks	24	Wire Brushes	56
		Repair Parts, Drum	80-81	Wood Blocks and Holders	63
		Repair Parts, Pedal	41	Xylophones	98 to 109
		Rooster Crow	70	Xylophone and Bell Mallets	97
		Rumble Tips	53	Xylophone Solos	83
				Xylophone Stand	109

Marimba, Xylophone and Vibraphone Trunks and Cases Listed With the Instruments

Leedy

CATALOG "U"

"THE
WORLD'S FINEST
DRUMMERS'
INSTRUMENTS"



Ted Fio-Rito's Splendid Radio and Stage Orchestra Which Was Recently Featured In Warner Bros. "Twenty Million Sweethearts" Gets Its Rhythm From Charles M. Pelce Who Is Shown Above With None Other Than The Popular Director Ted Fio-Rito Himself. Drums, Tympani, Vibraphone, Chimes and Bells Are Leedy.