

Pearl®

Pearl

NEW SOUND VENTURE

- 322 OUTFIT (Available Shells: Fiberglass, Maple, Dynamic Wood)
 - 14"x22" Bass drum
 - 717T Vari System Tom Holders
 - 4414D 6½"x14" Deluxe Metal Snare Drum
 - 8"x12" Tom Tom
 - 9"x13" Tom Tom
 - 14"x14" Floor Tom
 - 16"x16" Floor Tom
- 803 Cymbal Stands, 2-pcs.
- 800 Hi-Hat Stand
- 806 Snare Drum Stand
- 810 Drum Pedal
- Wire brushes & Sticks



Orange Flash Illustrated No. 62

POWER MATE

- 422 OUTFIT (Available Shells: Fiberglass, Maple, Dynamic Wood)
 - 14"x22" Bass Drum
 - 717T Vari System Tom Holders
 - 4414 5"x14" Deluxe Metal Snare Drum
 - 8"x12" Tom Tom
 - 9"x13" Tom Tom
 - 16"x16" Floor Tom
- 803 Cymbal Stands, 2-pcs.
- 800 Hi-Hat Stand
- 806 Snare Drum Stand
- 810 Drum Pedal
- Wire brushes & Sticks



Deep Ocean Illustrated No. 65

BUTCH MILES

BILLY HEART

GREGG FIELD
"COUNT BASIE ORC."

ALPHONSE MOUZON

ART BLAKEY



NEW DYNA-FAMILY

- 140 OUTFIT (Available Shells: Fiberglass, Maple, Dynamic Wood)

14"x24" Bass Drum
 14"x20" Bass Drum
 727T Twin-Tom Holders, 2-pcs.
 4414D 6½" x 14" Deluxe Metal Snare Drum
 5½" x 8", 6½" x 10" Concert Toms
 9" x 13", 8" x 12" Concert Toms
 10" x 14", 14" x 16" Concert Toms
 16" x 18" Floor Tom
 803 Cymbal Stands, 2-pcs.
 903BST Cymbal Boom Stand w/ AX-3 & 727T
 800 Hi-Hat Stand
 820 Hi-Hat Attachment
 806 Snare Drum Stand
 810 Drum Pedals, 2-pcs.
 Wire brushes & Sticks



Yellow Flash Illustrated No. 60

NEW FULL DIMENSION

- 222-1 OUTFIT (Available Shells: Fiberglass, Maple, Dynamic Wood)

14"x22" Bass Drum, 727T Tom Holders
 4414 5"x14" Deluxe Metal Snare Drum
 6½" x 10", 8" x 12" Concert Toms
 9"x13", 10" x 14" Concert Toms
 16" x 16" Floor Tom
 803 Cymbal Stands, 2-pcs
 800 Hi-Hat Stand
 806 Snare Drum Stand
 810 Drum Pedal
 989 Concert Tom Stand w/727x2
 Wire brushes & Sticks

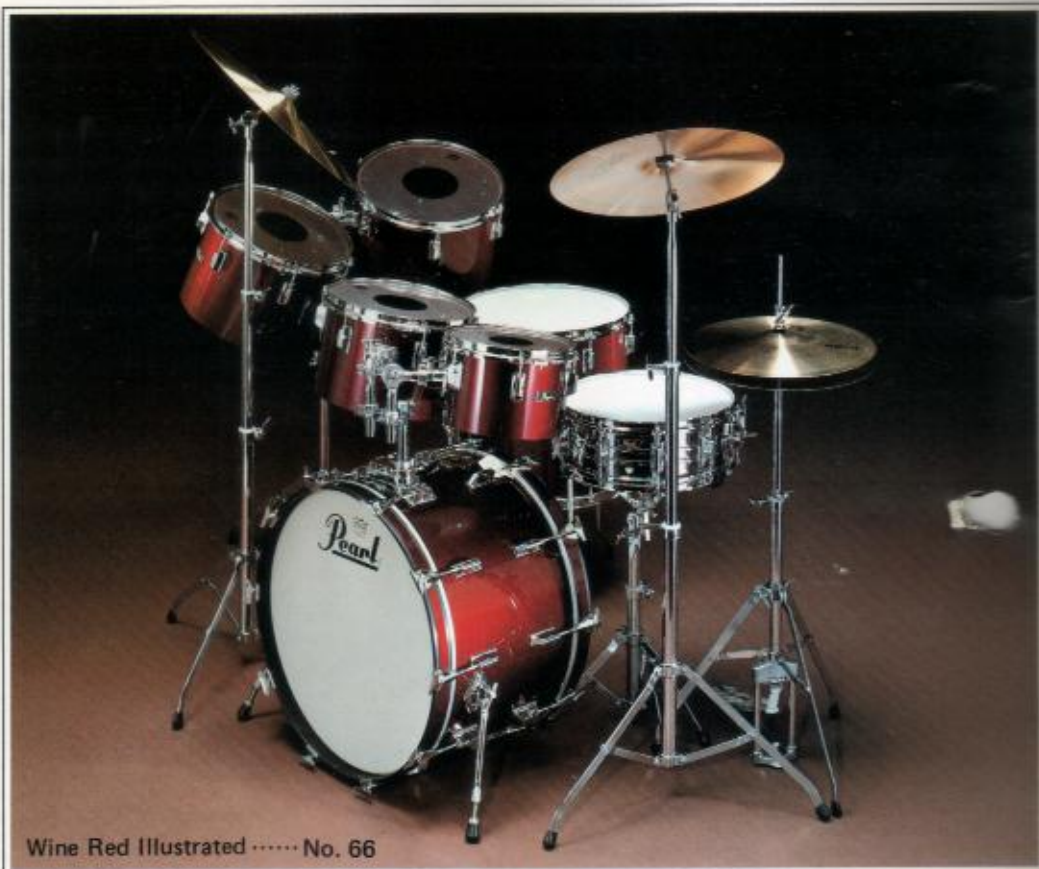

Wine Red Illustrated No. 66

BOB HENRIT

CHESTER THOMPSON

RAT SCABIES
 "THE DAMNED"

"H"
 "SELECTER"

"TOPPER" AKA
 NICKY HEADON
 "CLASH"





No. 38..... Chrome Metal Illustrated

ROCK KIT

- 424-1 OUTFIT (Available Shells: Fiberglass, Maple, Dynamic Wood)
- 14"x24" Bass Drum
- 717T Vari System Tom Holders
- 4414D 6½"x14" Deluxe Metal Snare Drum
- 9"x13" Tom Tom
- 10"x14" Tom Tom
- 16"x18" Floor Tom
- 803 Cymbal Stands, 2-pcs.
- 800 Hi-Hat Stand
- 806 Snare Drum Stand
- 810 Drum Pedal
- Wire brushes & Sticks



No. 58..... Red Flash Illustrated

FIBERGLASS HARD ROCK KIT

- 424-2 OUTFIT (Available Shell: Fiberglass Only)
- 14"x24" Bass Drum,
- 717T Vari System Tom Holders
- 4414D 6½"x14" Deluxe Metal Snare Drum
- 10"x14" Tom Tom
- 12"x15" Tom Tom
- 16"x18" Floor Tom
- 803 Cymbal Stands, 2-pcs.
- 800 Hi-Hat Stand
- 806 Snare Drum Stand
- 810 Drum Pedal
- Wire brushes & Sticks

BRAD
"SPECIALS"

BUTCH TRUCKS
"ALLMAN BROTHERS"

STIX HOOPER
"CRUSADERS"

DENNIS DAVIS
"STEVIE WONDER &
"WONDER LOVE"

ANDY WARD
"CAMEL"



CONTEMPORARY-I

- 620-1 OUTFIT (Available Shells: Fiberglass, Maple, Dynamic Wood)
 - 14"x20" Bass Drum
 - 717T Vari System Tom Holders
 - BA-414D 6½"x14" Birchfiber Snare Drum
 - 6½" x 10" Tom Tom (8"x10" in Fiberglass)
 - 9" x 13", 8" x 12" Tom Toms
 - 14" x 14" Floor Tom
 - 989 Twin-Tom Stand w/717 & 725
 - 903BST Cymbal Boom Stands, 2-pcs (one with AX-3 & 725)
 - 900 Hi-Hat Stand
 - 906 Snare Drum Stand
 - 910 Drum Pedal
 - Wire brushes & Sticks



Green Flash Illustrated No. 61

CONTEMPORARY-II

- 620-2 OUTFIT (Available Shells: Fiberglass, Maple, Dynamic Wood)
 - 14"x20" Bass Drum
 - 717T Vari System Tom Holders
 - BA-414D 6½"x14" Birchfiber Snare Drum
 - 6½"x10" Tom Tom (8"x10" in Fiberglass)
 - 8" x 12" Tom Tom
 - 9" x 13" Tom Tom
 - 10" x 14" Tom Tom
 - 989 Twin Tom Stand w/AX-3 & 725
 - 903 Cymbal Stand
 - 903BST Cymbal Boom Stand w/725 & AX-3
 - 900 Hi-Hat Stand
 - 906 Snare Drum Stand
 - 910 Drum Pedal
 - Wire brushes & Sticks



Green Flash Illustrated No. 61

RICHIE MORALES
"BRECKER BROTHERS BAND"

SCOTT MORRIS
"RICHIE COLE AND ALTO MADNESS"

KEITH KNUDSEN
"DOOBIE BROTHERS"

CHET MCCRACKEN
"DOOBIE BROTHERS"

JOHN WALTERS
"DR. HOOK"





No. 60 Yellow Flash Illustrated

INNOVATION KIT

- **W-12 OUTFIT (Available Shell: Regular Ply-wood Only)**
- 14"x22" Bass Drum
- 4414D 6½"x14" Deluxe Metal Snare Drum
- 6½"x10"
- 8"x12" Tom Toms
- 9"x13"
- 10"x14"
- 16"x16" Floor Tom
- 903BST Cymbal Boom Stands w/ AX-3 & 727T, 2-pcs.
- 725 Cymbal Holder
- 703 Cymbal Stand
- 800 Hi-Hat Stand
- 706 Snare Drum Stand
- 710 Drum Pedal
- Wire Brushes & Sticks



No. 63 Brown Flash Illustrated

NEW THUNDER-KING

- **W-68 OUTFIT (Available Shell: Regular Ply-wood Only)**
- 14"x22" Bass Drum, 727T Twin Tom Holder
- 4414 5"x14" Deluxe Metal Snare Drum
- 8"x12" Tom Tom
- 9"x13" Tom Tom
- 16"x16" Floor Tom
- 703 Cymbal Stands, 2-pcs.
- 800 Hi-Hat Stand
- 706 Snare Drum Stand
- 710 Drum Pedal
- Wire Brushes & Sticks

TERRY JENKINS
"JAMES LAST ORCHESTRA"

WILLI KETZER

GEOFF COX

GRAHAM MORGAN

RON SANDILANDS



THE VARI SET SYSTEM

A system totally adaptable to the many different set-ups demanded by the modern drummer. It enables the player to use many combinations of tom-toms and cymbals to produce the wide range of sounds required today. The AX-3 adaptor is the key to the entire system, providing each drummer with an unlimited choice of set-ups.



● 717T

A tom-tom holder designed for the professional drummer —

Permits multi-angle adjustment, while retaining total stability. Single screw tension ensures no slip during use.

Each arm has two lock-stop memory clips, for instant reset of each individual tom-tom. Can also be combined with Vari Set System for even greater flexibility.



● 727T

A new standard in tom-tom holders.

Capable of holding any Pearl Professional Tom-Tom as pipe diameter is the same.

Wide range of usage — The Vari Set System can be used. This holder also features Pearl's own lock-stop memory clips.

Triple Tom can be set by AX-3 adaptor as well.



Combination of Toms & Holders on the 989 Twin Tom Stand.



Set-up with two adaptors, 725 Cymbal Holder, and 717 Twin Tom Holder.

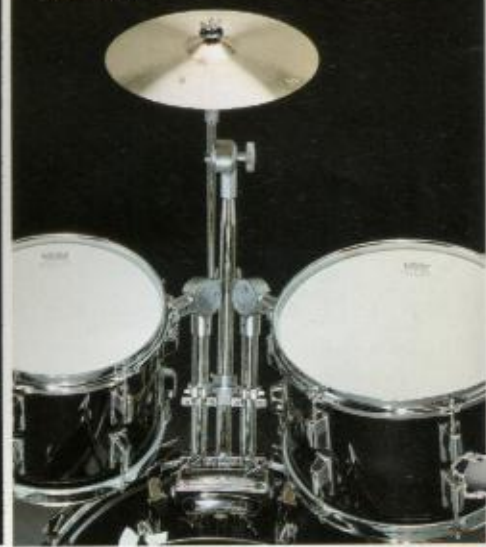

Pearl's Vari Set offers all the flexibility you need.



AX-3 Adaptor — is the key to the entire system.

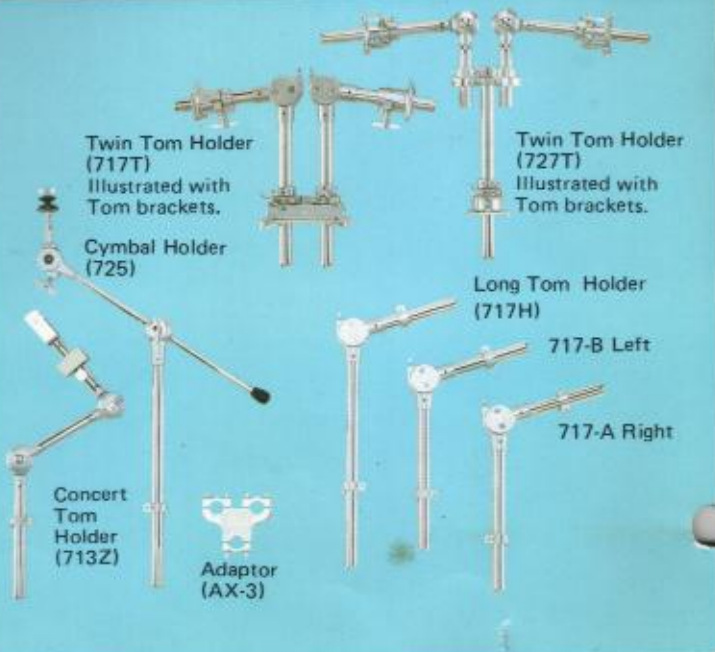

TOM-TOMS

CONCERT-TOMS

Fiberglass Shell

- A. 8" x 8" D. 9" x 13"
- B. 8" x 10" E. 10" x 14"
- C. 8" x 12" F. 12" x 15"

Maple & Dynamic Wood

- A. 6 1/2" x 10" C. 9" x 13"
- B. 8" x 12" D. 10" x 14"

Available Shell: Fiberglass, Maple, Dynamic Wood

- A. 5 1/2" x 8" C. 8" x 12" E. 10" x 14"
- B. 6 1/2" x 10" D. 9" x 13" F. 14" x 16"



Bracket

Pipe diameter of stand and tom-tom holder are the same, allowing for the combination of a regular tom-tom with the concert tom, or cymbal boom arm. Contemporary feel of this bracket can be appreciated when being used.

LATIN PERCUSSION

Congas



- 212F 12" dia. x 30" deep (with Legs or Stand)
- 211F 11" dia. x 29" deep (with Legs or Stand)
- 210F 10" dia. x 28" deep (with Legs or Stand)

*GB-40 Conga Stand, Double Braced Legs
*Available in choice of color Black or White.

Timbales



- 213 13" and 14" dia. x 6-1/2" deep with Tilting stand (STEEL SHELLS)
- B-213 13" and 14" dia. x 6-1/2" deep with Tilting stand (BRASS SHELLS)

SNARE DRUMS

B-414D

BC-414

Walnut
Illustrated

F-314D

Chrome
Illustrated

BA-414D

Yellow Flash
Illustrated

4414



Pearl offers a unique choice of shell materials and sizes to produce any sound and compliment your style of music. Standard available sizes are 5" x 14", 6½" x 14", and the new extra deep 8" x 14". Shell materials include 6-ply Birch in the lacquered or covered, chrome plated steel shell, brass shell chrome plated, fiberglass shell in choice of covering material.

BC-414ED

Natural Birch
Illustrated

G-314

Pure White
Illustrated

4214



MODEL	SIZE	SHELL MATERIAL	FINISH	STRAINER	RIM	LUGS
B-414D	6½" x 14"	Brass	Chrome	S-017	Die-cast	10 double
B-414	5" x 14"	Brass	Chrome	S-017	Die-cast	10 double
BC-414ED	8" x 14"	Birch	Lacquer, Covering	S-017	Die-cast	20 single
BC-414D	6½" x 14"	Birch	Lacquer, Covering	S-017	Die-cast	10 double
BC-414	5" x 14"	Birch	Lacquer, Covering	S-017	Die-cast	10 double
BA-414ED	8" x 14"	Birchfiber	Lacquer, Covering	S-017	Die-cast	20 single
BA-414D	6½" x 14"	Birchfiber	Lacquer, Covering	S-017	Die-cast	10 double
G-314D	6½" x 14"	Maple	Covering	S-015	Die-cast	10 double
G-314	5" x 14"	Maple	Covering	S-015	Die-cast	10 double
F-314D	6½" x 14"	Fiberglass	Covering	S-015	Die-cast	10 double
4214D	6½" x 14"	Brass	Chrome	S-015	Metal	10 double
4214	5" x 14"	Brass	Chrome	S-015	Metal	10 double
4414D	6½" x 14"	Steel	Chrome	S-015	Metal	10 double
4414	5" x 14"	Steel	Chrome	S-015	Metal	10 double

Strainers

S-017:

New Parallel Wing Strainer. An easy-to-operate, smooth-action strainer, snare can be set or released with a light touch. Also features simple adjustment of tension for obtaining just the right sound.

S-015:

Die-cast Strainer.

800 ACCESSORIES



Drum Pedal

- 810N
Professional Model

Cymbal Stands

- 803BD Cymbal Boom Stand, Double braced legs
- 803 Professional Cymbal Stand

Hi-Hat Stand

- 800
Professional Model

Snare Drum Stand

- 806
Professional Model

Drummer's Throne

- 850
Professional Model



803BD

803

800

806

850

900 ACCESSORIES

910 Drum Pedal

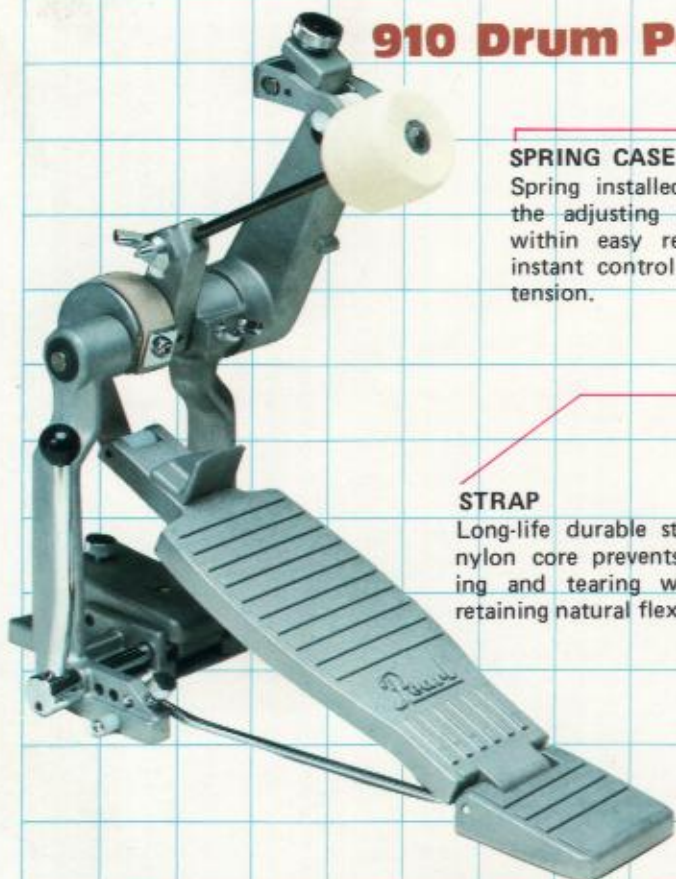

SPRING CASE

Spring installed inside, with the adjusting knob on top within easy reach, allowing instant control of the spring tension.

STRAP

Long-life durable strap with nylon core prevents stretching and tearing while still retaining natural flexibility.

BEATER BALL

A newly developed beater shaft, constructed of strong, tensile steel, gives immense power and ensures that beater strikes at correct angle.

BEATER ANGLE ADJUSTMENT

Allows for adjustment of beater to precise angle required by each drummer.

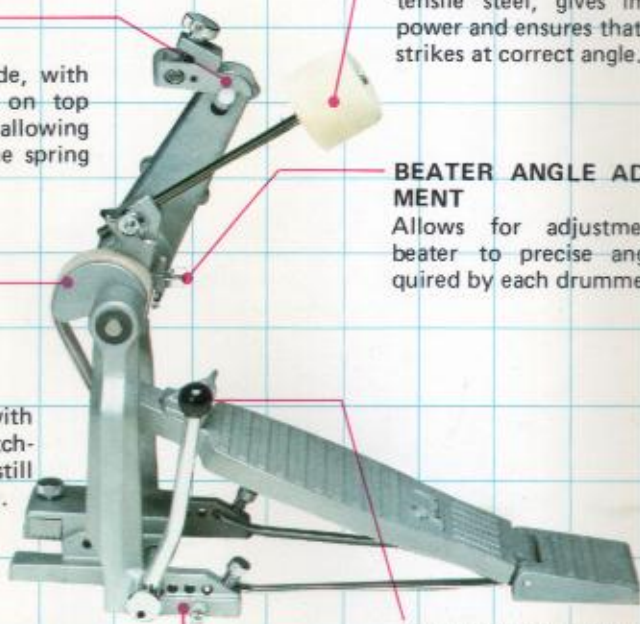

FOOT PLATE ADJUSTMENT

Adjustment of foot plate to choice of three positions.

ONE TOUCH LOCK SYSTEM

Instant setting and re-setting on bass-drum hoop in one easy lever movement.

Twin-Tom & Concert-Tom Stand

• 989H

Snare Drum Stand

• 906

Drummer's Throne

• 950

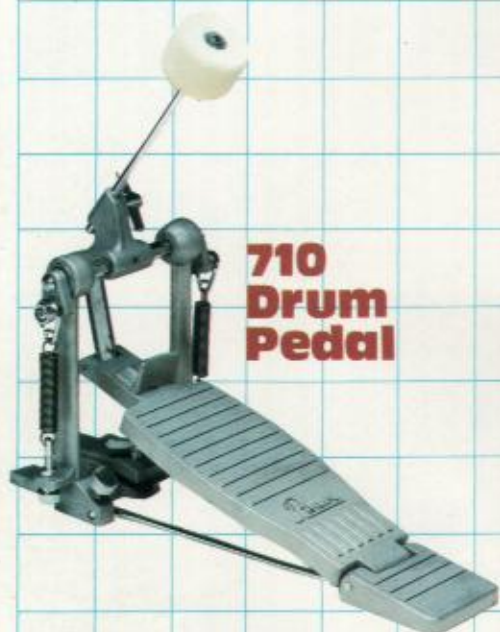

710 Drum Pedal

- Simple mechanism permits light and easy control
- Double spring system for fluid foot action
- Sandblast finish.



989H

with 717T for Tom Tom
with 727T for Concert Tom

906

950

900 Hi-Hat Stand

Clutch — 3 point lock system ensures firm clamping of cymbals to shaft.

Parallel spring system — ensures smooth movement for both light and heavy foot pressure.

Joint — stopper attached to joint to guarantee sure grip during even the heaviest of foot pressure.



Revolving Stopper

Choice of use of rubber tip or steel point to match any floor finishes, makes the stand secure and stable.



Die-cast Joint

New interchangeable die-cast joint together with the memory stop system is used on all Stands and Drummer's Throne.



900

Cymbal Stand

- 903B Cymbal Boom Stand
- 903BST Cymbal Boom Stand (Short)
- 903 Cymbal Stand

Perfect stability and the new application of die-cast joints and VARI system tilter, make the stand completely new in appearance.



Tilter

Uni-lock system devised for adjustment of tilt angle up to 175° —

Cymbal stabilizer presents cymbal from shaking excessively.

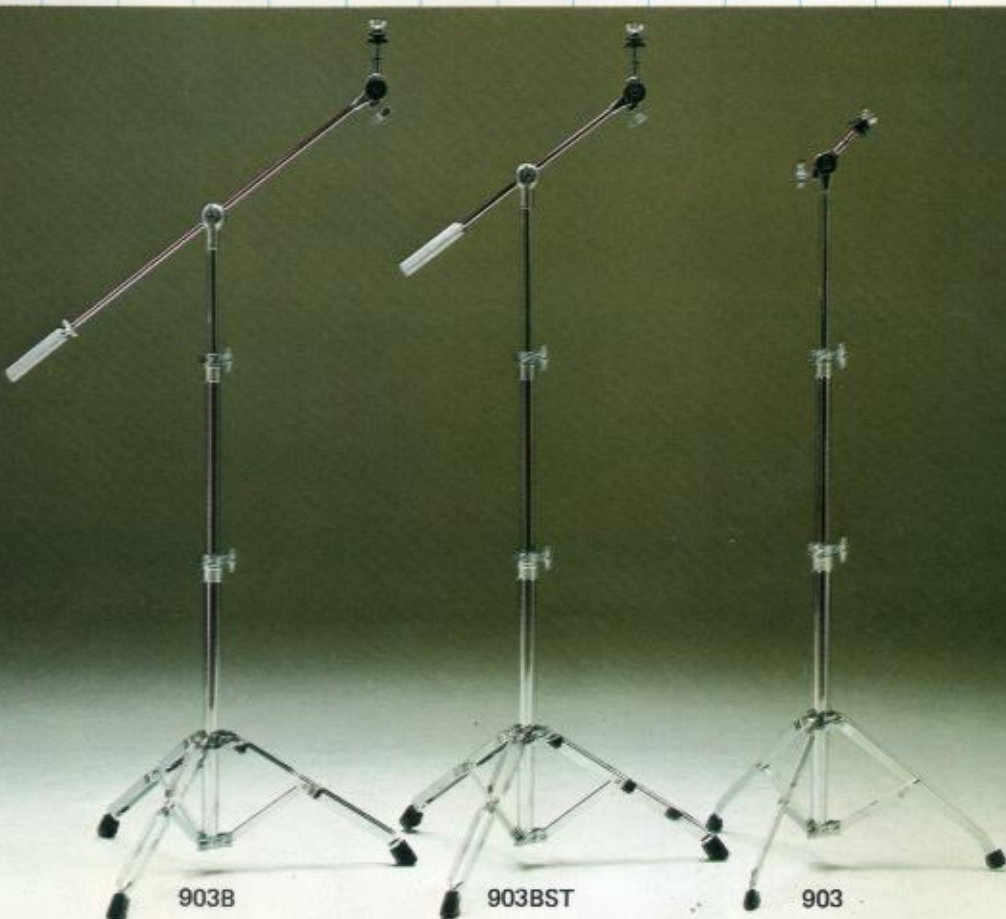

903B

903BST

903

HAND MADE DRUM STICKS

Hickory Sticks



7H	Popular Model	13/25" dia. x 15-5/8" long
9H	Super-Balance Model	14/25" dia. x 16" long
11H	Rock Model	14/25" dia. x 16" long
101H	Rock Model	14/25" dia. x 16" long
102H	Rock Model	14/25" dia. x 16" long
103H	Jazz Model	14/25" dia. x 15-1/8" long
104H	Rock Model	15/25" dia. x 16-1/8" long
105H	Rock Model	16/25" dia. x 16" long

1A	Jazz Model	16" long
3A	Dance or Concert Model	16" long
5A	Rock Model	15-1/4" long
7A	Popular Jazz Model	15-5/8" long
8A	Popular Jazz Model	15-1/2" long
9A	Super-Balance Model	16" long

Oak Sticks

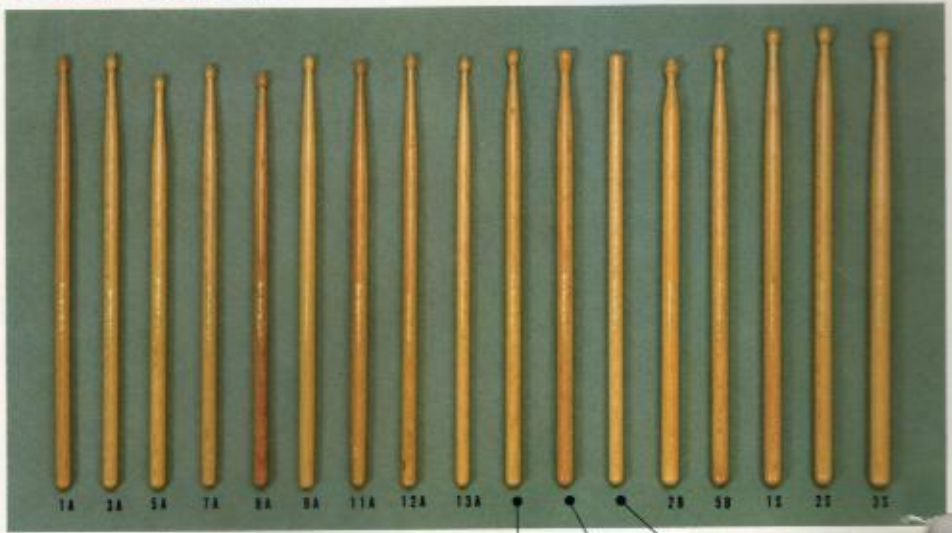

11A	Rock Model	15-3/4" long
12A	Jazz Model	16-1/2" long
13A	Custom Multi-Purpose Model	15-7/8" long

Rock-101	Rock Model	16" long
Rock-105	Rock Model	16" long
Rock-Knocker	Rock Model	16" long
2B	Medium-heavy School Model	15-7/8" long
5B	Medium-weight School Model	16" long
1S	Medium-heavy School Model	16-7/8" long
2S	Heavy Parade Model	17" long
3S	Heaviest Parade Model	17" long

ACCESSORIES

Stick Case



• SC-3
Stick Case with
Punching Mat

Mallets

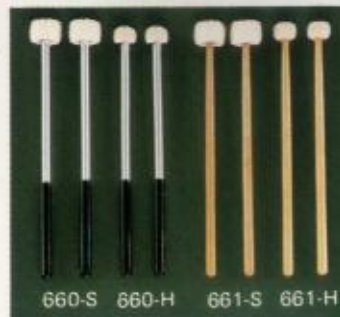

660-S 660-H 661-S 661-H

Wire & Nylon Brushes



722N 722C 722B 722



Sticky Muffler

(1 set includes 2 sheets) STM-1
An adhesive felt sheet which
can be easily cut with a scis-
sors to desired shape and size
to achieve desired tone and
volume control.

Bass Drum Beaters

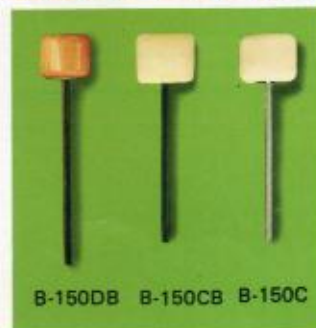

B-150DB B-150CB B-150C

• Bass Drum Beaters
B-150DB
Wood w/Black Shaft
B-150CB
Felt w/Black Shaft
B-150C
Felt

COLOR FINISHES

No. 19 New Marine Pearl

No. 31 Jet Black

No. 33 Snow White

No. 38 Chrome Metal

No. 55 Silver Flash

No. 56 Gold Flash

No. 57 Blue Flash

No. 58 Red Flash

No. 60 Yellow Flash

No. 61 Green Flash

No. 62 Orange Flash

No. 63 Brown Flash

No. 64 Army Green

No. 65 Deep Ocean

No. 66 Wine Red

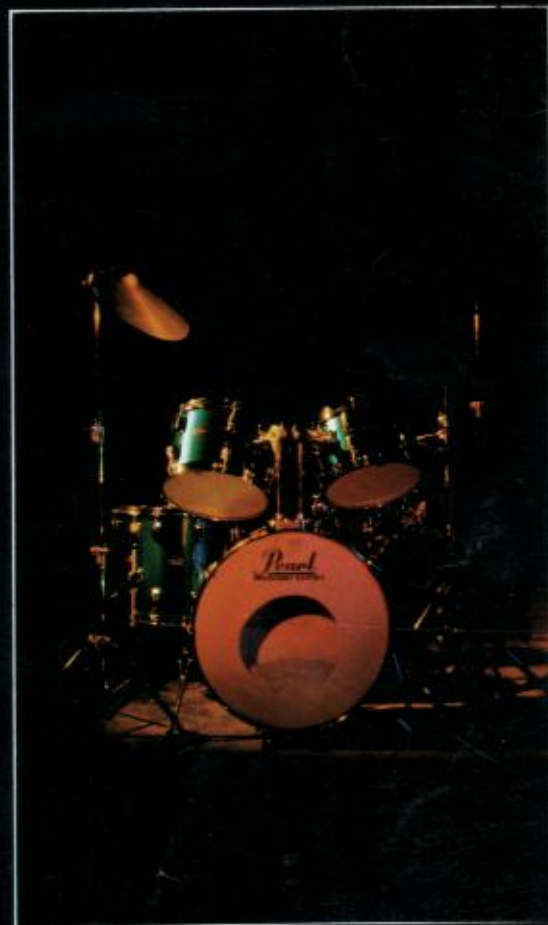

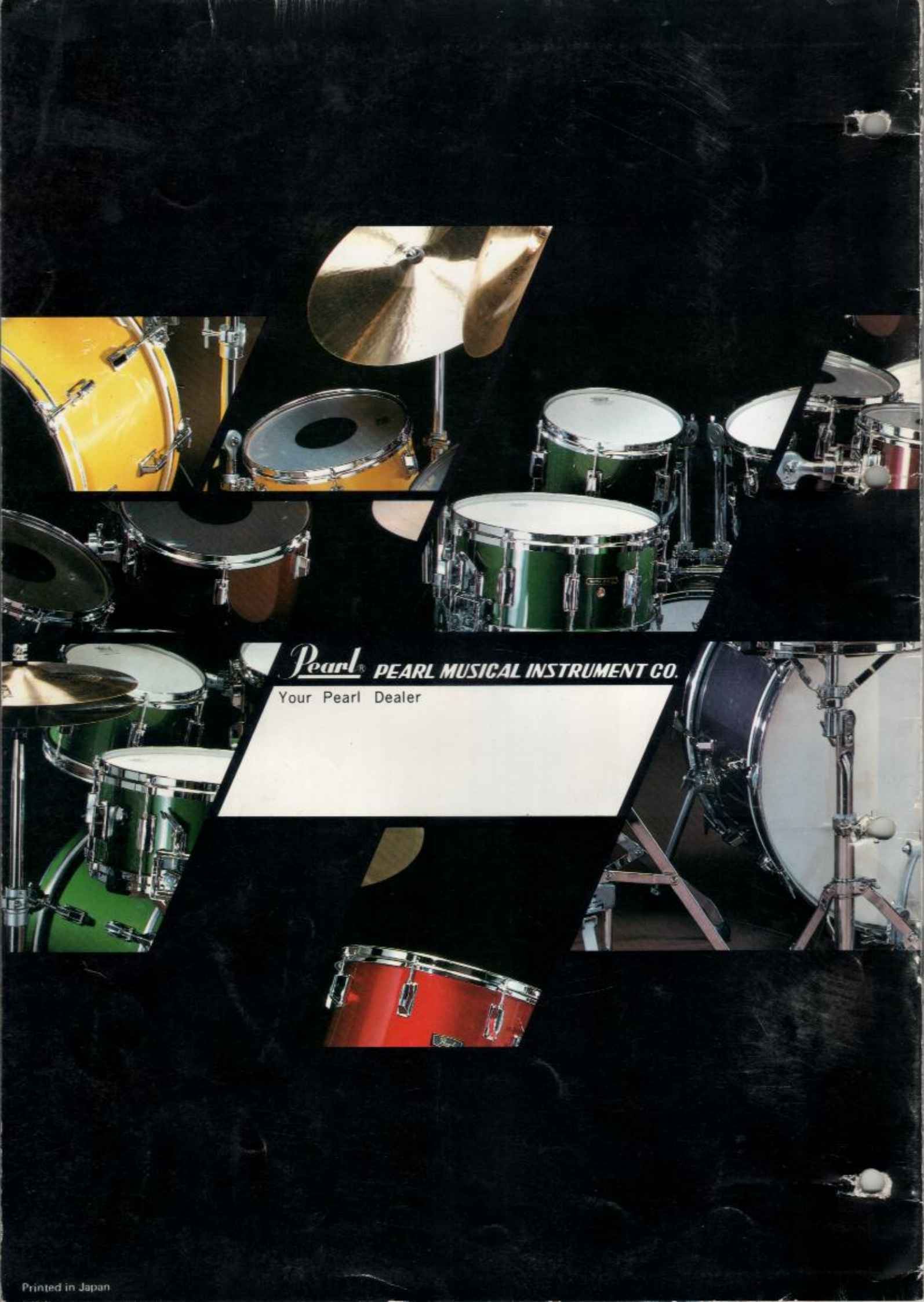

Pearl PEARL MUSICAL INSTRUMENT CO.

Your Pearl Dealer

THE DRIVING FORCE

Pearl®

SHELL TYPES

Fiberglass Shell

Power —
Overall Durability —
Bright and instant response.
Flexibility in use
Suitable for all types of music
Totally unaffected by humidity.
The drum manufacturers most modern shell material. Known and admired by drummers throughout the world for its many qualities.

Maple Shell

Made of selected maple — wide variety in sound, sensitive, powerful, yet retaining the warmth and mellowness of a traditional wood shell.
Shell interior finished with clear lacquer polish.

Dynamic Wood Shell (Birch)

A nine layer ply-wood body finished by the heat compression method and a birch interior surface produces its dynamic and mellow sound.

