

PEARL
DRUMS
PROFESSIONAL
SERIES



MLX-22D-7 Illustrated in No.108 Charcoal Gray Cymbals not included

Pearl's MLX Series maple shell drum kits, perennial favorites of discriminating players worldwide, feature advanced concepts in design, performance, and playability. In the MLX Series, high tension lugs and the finest lacquer finishes available are combined with Pearl's 100 percent maple shells. MLX shells are crafted from selected close-grained maple for high integrity, dynamic projection, and warmth of sound. On going acoustical research, hardware development, and attention to detail continue to make Pearl the world's leading percussion manufacturer.

ALL MAPLE SHELL

Selected high density maple, aged and air cured for perfect moisture control, is cross laminated into 6-ply shells through a high heat compression molding process. The outstanding characteristics of maple are the power, projection, and warmth built into each shell, with a tuning range which fits all playing situations.

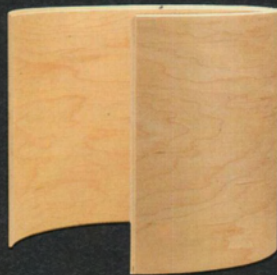

MLX-22D-5 Illustrated in No.102 Natural Maple Cymbals not included

PRESTIGE CUSTOM 8500 MLX SERIES



MLX-22DW-9 Illustrated in No.110 Sequoia Red Cymbals not included

			PRESTIGE CUSTOM 8500 MLX SERIES							
			MLX-22D-5	MLX-22D-6	MLX-22D-7	MLX-22DW-9	MLX-24D-5	MLX-24D-6	MLX-24D-7	MLX-24DW-9
Bass Drum	16" x 22"	MLX-222D	•	•	•	••				
	16" x 24"	MLX-224D					•	•	•	••
Tom Tom	8" x 10"	MLX-210D		•	•	•		•	•	••
	10" x 12"	MLX-212D	•	•	•	•		•	•	•
	11" x 13"	MLX-213D		•	•	•		•	•	•
	12" x 14"	MLX-214D		•	•	•		•	•	•
Floor Tom	14" x 15"	MLX-215D		•	•	•		•	•	•
	16" x 16"	MLX-2116	•	•	•	•		•	•	•
Snare Drum	16" x 18"	MLX-2118		•	•	•		•	•	•
	6½" x 14"	B-914D	•	•	•	•		•	•	•
Hi-Hat Stand	H-900	•	•	•	•		•	•	•	•
Snare Drum Stand	S-900W	•	•	•	•		•	•	•	•
Cymbal Stand	C-800W	•	•	•	•		•	•	•	•
Cymbal Boom Stand	B-800W	•	•	•	•		•	•	•	•
Foot Pedal	P-880	•	•	•	•••		•	•	•	•••
Tom Holder	TH-95	••	••	••	••••	••	••	••	••	••••
	TH-95S									
Adaptor	AX-20		•	••			•	••		

Cymbals not included



MX-22DW-9 Illustrated in No.38 Stainless Steel Cymbals not included



MX-22D-5 Illustrated in No.33 Pure White Cymbals not included

Pearl's MX Series features the same all-maple shell construction as the MLX Series, combined with covered finishes including Stainless Steel and Ferrari Red. The inside of each shell is clear-lacquered to create a moisture barrier and optimize acoustic quality. The MX Series also features the famous "Free Floating System" Snare Drum and the smooth, quick and quiet Chain Drive Foot Pedal.

ALL MAPLE SHELL

The selected maple, inspected under strict quality control, is then scarf-cut joined to assure maximum strength in the shell ply joints. Then, using cross laminations in Pearl's exclusive high heat compression mold, the 6-ply shell is formed into a perfect circle.

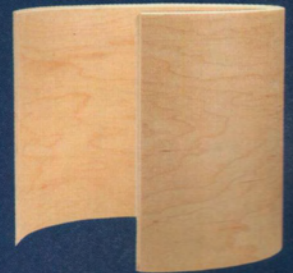



MX-22D-7 Illustrated in No.71 Ferrari Red DR-1 Drum Rack and Cymbals not included

CUSTOM 8500 MX SERIES

			CUSTOM 8500 MX SERIES							
			MX-22D-5	MX-22D-6	MX-22D-7	MX-22DW-9	MX-24D-5	MX-24D-6	MX-24D-7	MX-24DW-9
Bass Drum	16" x 22"	MX-222D	●	●	●	●●	●	●	●	●●
	16" x 24"	MX-224D								
Tom Tom	8" x 10"	MX-210D		●	●	●				
	10" x 12"	MX-212D		●	●	●				●
	11" x 13"	MX-213D	●	●	●		●	●	●	●
	12" x 14"	MX-214D		●	●		●	●	●	●
	14" x 15"	MX-215D		●	●		●	●	●	●
Floor Tom	16" x 16"	MX-2116	●	●	●	●	●	●	●	●
	16" x 18"	MX-2118					●	●	●	●
Snare Drum	6 1/2" x 14"	B-914D	●	●	●	●	●	●	●	●
Hi-Hat Stand		H-900	●	●	●	●	●	●	●	●
Snare Drum Stand		S-900W	●	●	●	●	●	●	●	●
Cymbal Stand		C-800W	●	●	●	●	●	●	●	●
Cymbal Boom Stand		B-800W	●	●	●	●	●	●	●	●
Foot Pedal		P-880	●	●	●	●●	●	●	●	●●
Tom Holder		TH-95	●●	●●	●	●●●	●●	●●	●●	●●●
		TH-95S			●●	●●			●●	
Adaptor		AX-20		●	●●		●	●●		

Cymbals not included

PRESTIGE STUDIO 7500 BLX SERIES



BLX-22D-6 Illustrated in No.107 Coral Red Cymbals not included

			PRESTIGE STUDIO 7500 BLX SERIES							
			BLX-22D-5	BLX-22D-6	BLX-22D-7	BLX-22DW-9	BLX-24D-5	BLX-24D-6	BLX-24D-7	BLX-24DW-9
Bass Drum	16" x 22"	BLX-222D	•	•	•	••				
	16" x 24"	BLX-224D					•	•	•	••
Tom Tom	8" x 10"	BLX-210D		•	•	•				
	10" x 12"	BLX-212D		•	•	•				
	11" x 13"	BLX-213D	•	•	•	•	•	•	•	•
	12" x 14"	BLX-214D		•	•	•				
	14" x 15"	BLX-215D		•	•	•				
Floor Tom	16" x 16"	BLX-2116	•	•	•	•	•	•	•	•
	16" x 18"	BLX-2118					•	•	•	•
Snare Drum	6 1/2" x 14"	S-814D	•	•	•	•	•	•	•	•
Hi-Hat Stand	H-900		•	•	•	•	•	•	•	•
Snare Drum Stand	S-900W		•	•	•	•	•	•	•	•
Cymbal Stand	C-800W		•	•	•	•	•	•	•	•
Cymbal Boom Stand	B-800W		•	•	•	•	•	•	•	•
Foot Pedal	P-880		•	•	•	••	•	•	•	••
Tom Holder	TH-95		••	••	••	••••	••	••	••	••••
	TH-95S			••	••	••		••	••	••
Adaptor	AX-20		•	•	•		•	•	•	

Cymbals not included



BLX-22D-7 Illustrated in No.109 Arctic White Cymbals not included

This professional series lacquer finished 100 percent birch shell is also the product of Pearl's exclusive high pressure molding system, guaranteeing a shell free of laminate gaps. This high pressure molding system enhances the powerful projection while keeping the great sound of birch. An additional result of this process is a drum with an attack and response that mikes well on the road or in the studio.

ALL BIRCH SHELL

The inherent density, grain, and characteristics of birch produce the powerful sound that is so unique to this wood.



BLX-22D-5 Illustrated in No.103 Piano Black Cymbals not included

With the most sophisticated engineering technology and more than 40 years of research, design, and production experience, Pearl produces the finest Professional Drum Components available. Dedication to precision details, from material selection through shell molding, bearing edges, and durability of shells and hardware guarantee the consistent quality required by professionals worldwide.



BB-2 BASS DRUM BRACKET

A rock solid bass drum bracket supports Pearl's "Independent Suspension System" tom holder, a feature which allows total angle and axis adjustment for each individually mounted tom tom. Stop-Locks make it possible to quickly reset the tom tom's to the desired height and angle time after time. Nylon bushings in the bass drum bracket prevent metal-to-metal contact and eliminate noise in all miking situations.

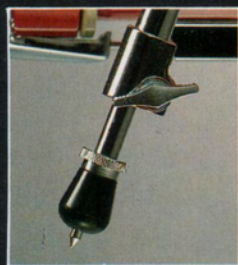

730P BASS DRUM SPURS

Telescopic spurs can be adjusted, virtually eliminating bass drum creep. The ends can be converted quickly from steel spikes to rubber tips, depending on the floor condition.

BASS DRUMS

Pearl offers five bass drum sizes to cater to the needs of all players. Pinstripe heads on batter sides and Pearl's Black Beat front heads are standard on MX, MLX, and BLX Lines. Lacquered hoops to match the finishes on MLX and BLX units and matte-black wood hoops with matching inlay on all MX units are standard.

Bass Drums

	MLX	MX	BLX
14" x 20"	MLX-220	MX-220	BLX-220
14" x 22"	MLX-222	MX-222	BLX-222
14" x 24"	MLX-224	MX-224	BLX-224

Deep-Force Series

	MLX-222D	MX-222D	BLX-222D
16" x 22"	MLX-222D	MX-222D	BLX-222D
16" x 24"	MLX-224D	MX-224D	BLX-224D

PEARL PROFESSIONAL DRUM SERIES





FLOOR TOM LEG BRACKET

The floor tom leg bracket locks the leg into position and prevents slipping or turning.

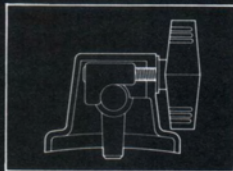

FLOOR TOMS

Each professional series provides floor toms in 16" x 16" or 16" x 18" sizes with "Super Hoops" plus Pinstripe heads on the batter sides and clear heads on the bottoms for the punchy resonance needed in today's music.

Floor Toms

	MLX	MX	BLX
16" x 16"	MLX-2116	MX-2116	BLX-2116
16" x 18"	MLX-2118	MX-2118	BLX-2118

TOM TOMS



BT-2 TOM TOM BRACKET

Nylon bushings, by preventing metal-to-metal contact, eliminate noise in all miking situations and make the solid installation of tom toms possible without damaging the tom holder pipe. Stop locks make it possible to set the tom tom to the desired position quickly and easily every time.

Pearl offers two basic tom tom size variations: "Standard", for traditional sounds and styles, and "Deep Force", for the penetrating punch and power demanded in many contemporary music situations.

Tom Toms

	MLX	MX	BLX
8" x 12"	MLX-212	MX-212	BLX-212
9" x 13"	MLX-213	MX-213	BLX-213
10" x 14"	MLX-214	MX-214	BLX-214
12" x 15"	MLX-215	MX-215	BLX-215

Deep-Force Series

	MLX	MX	BLX
8" x 8"	MLX-208D	MX-208D	BLX-208D
8" x 10"	MLX-210D	MX-210D	BLX-210D
10" x 12"	MLX-212D	MX-212D	BLX-212D
11" x 13"	MLX-213D	MX-213D	BLX-213D
12" x 14"	MLX-214D	MX-214D	BLX-214D
14" x 15"	MLX-215D	MX-215D	BLX-215D



Shown Left: Regular Hoop
Right: Super Hoop

SUPER HOOPS

Pearl's exclusive "Super Hoops", with a thickness of 2.3mm are unsurpassed by conventional hoops of 1.6mm, and are precision engineered to achieve a perfect fit to the shell and head. Super Hoops provide greater sound projection, positive even tuning and the strength to withstand the most stressful tensioning without warping. "Super Hoops" are standard equipment for all mounted and floor toms in all professional drum series.

COMPONENT DRUMS

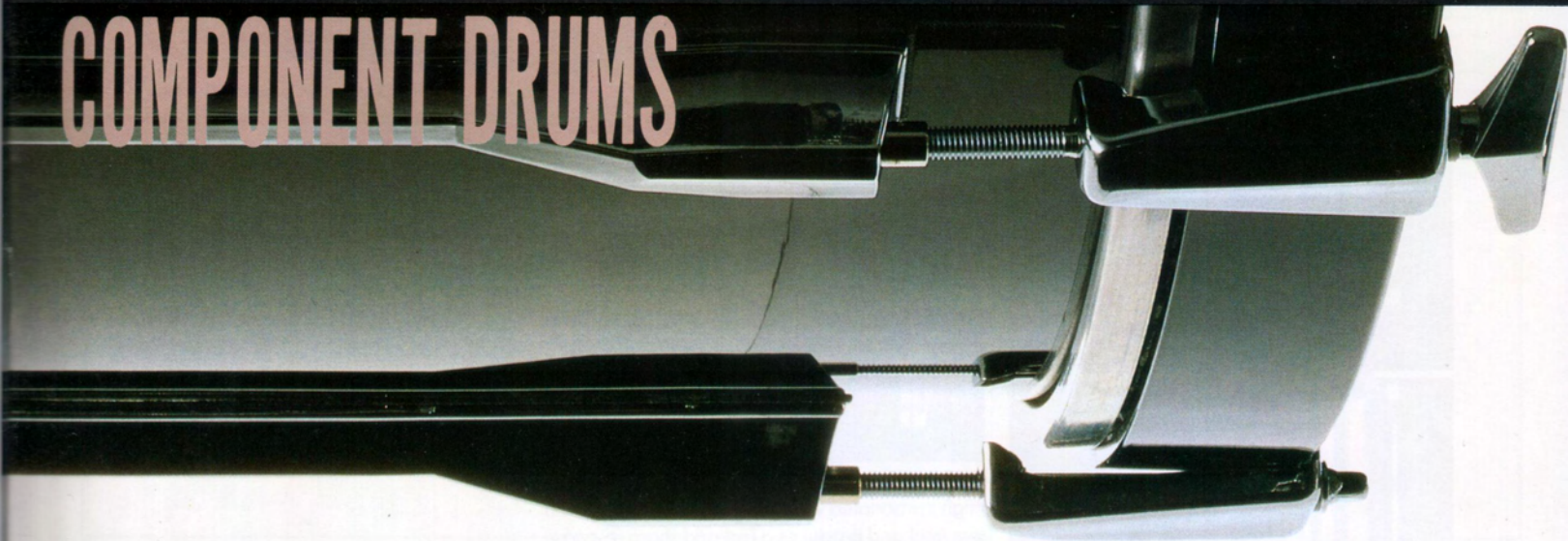

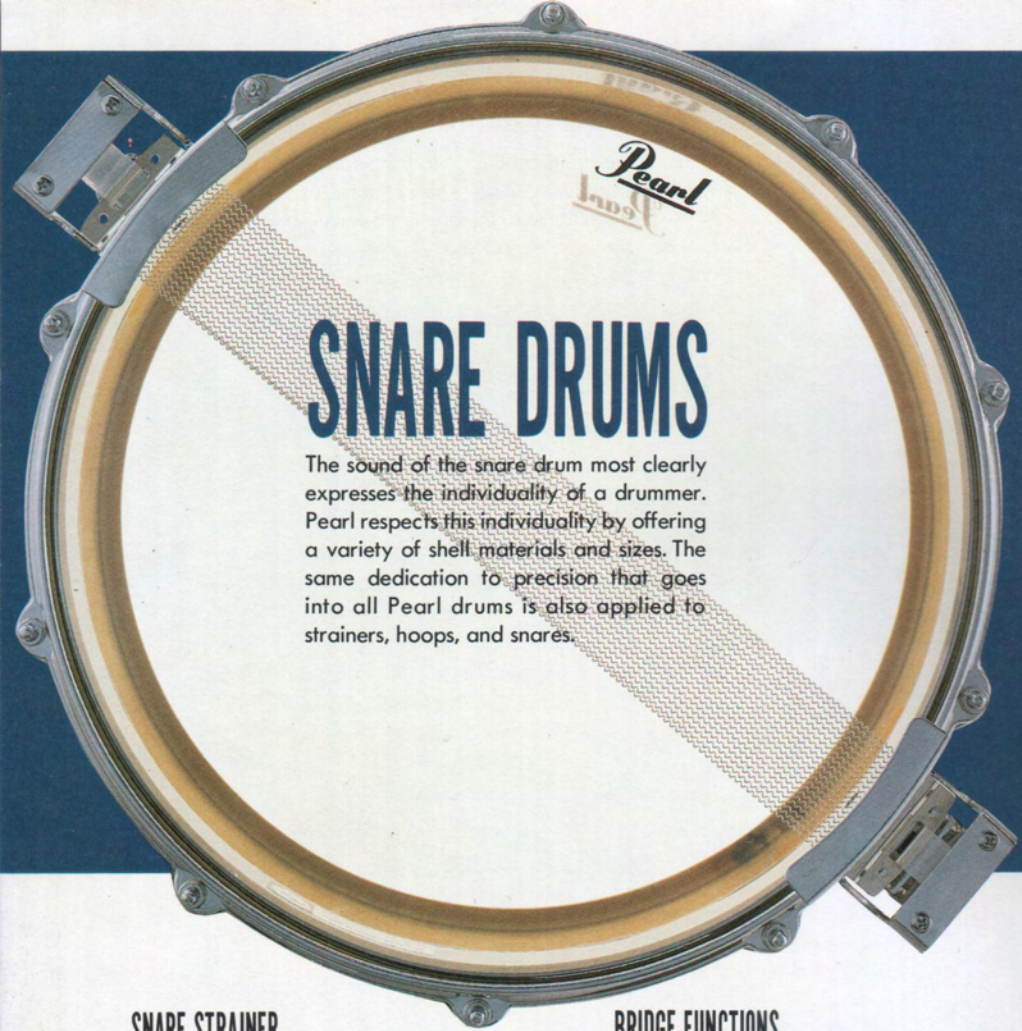

SNARE DRUMS

The sound of the snare drum most clearly expresses the individuality of a drummer. Pearl respects this individuality by offering a variety of shell materials and sizes. The same dedication to precision that goes into all Pearl drums is also applied to strainers, hoops, and snares.

SNARE STRAINER

Precise snare action can only be produced by utilizing a highly accurate strainer mechanism. Pearl's engineering offers precise sensitivity control to satisfy every drummer.

S-011 BRIDGE TYPE SINGLE-SIDE ACTION STRAINER

The S-011 strainer has been designed and developed to maximize the snare sensitivity. The snares, extended beyond the head diameter, are controlled and fully adjustable at both ends of the bridges. Critical snare tension adjustments may also be made at each end. (Snare tension is only adjustable from the throw-off side of the S-011E Strainer.)

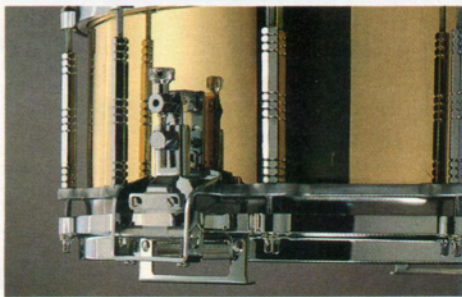
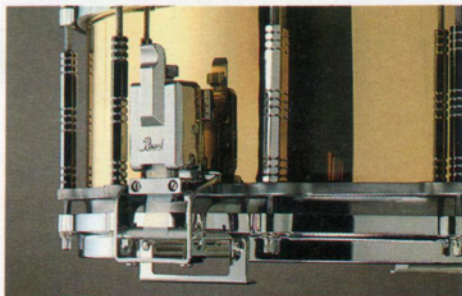

BRIDGE FUNCTIONS

Pearl's precision bridges are used to set the position of the snares against the bottom head of the snare drum. By tightening the screws at the bottom of each bridge, the snares can be positioned away from the snare bed, and by loosening them, the snares can be set into the bed.

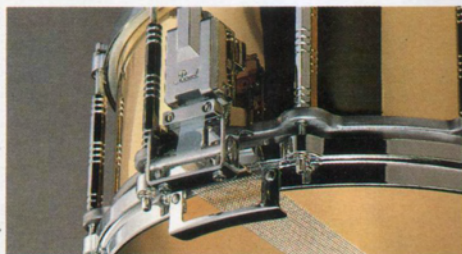

SNARES

Pearl offers two kinds of wire snares: Stainless steel and high carbon steel. Each individual strand on both types is securely installed for maximum durability.

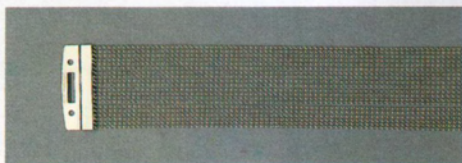

S-025 HIGH CARBONATED WIRE SNARE

High carbonated wire is slightly harder than stainless steel and produces a fast and sharp response.

S-025S STAINLESS STEEL WIRE SNARE

Stainless steel snares feature high spring tension with longer pitches on the wire to produce a fast and sharp response.

SNARE DRUM SHELLS

MAPLE SHELL

Pearl's precision molded, selected hard maple shells project power and yet retain the traditional color and warmth of wood that is indispensable to many drummers.

BRASS SHELL

Brass, the noble metal whose resonating properties have been proven in its use on many types of musical instruments, produces a uniquely beautiful blend of tone color and projection. From a sensitive response to the most powerful back beat, your mood is faithfully expressed.

STEEL SHELL

The seamless steel snare drum shell, roll-formed to a perfect circle, maintains a superior head-to-shell fit. Steel reproduces the most sensitive rolls and withstands the most powerful attacks, meeting the demands of all styles of music.

SHELL DEPTH

Pearl offers four snare drum shell depth—8", 6½", the standard 5", and a 3½" piccolo snare drum—a lineup that guarantees satisfaction.

DIE-CAST HOOPS

Seamless, heavy-duty zinc die-cast hoops with 10 holes instead of 8 make tuning easier and more accurate, and produce stronger rim shots.

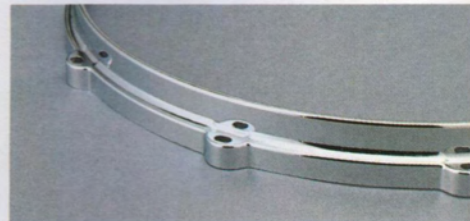

SUPER HOOPS

With a perfect fit to the shell and head, choking is eliminated and the "Super Hoop's" design transfers the attack directly into the drum. "Super Hoops" withstand the heaviest rimshots and the most stressful tuning without bending.

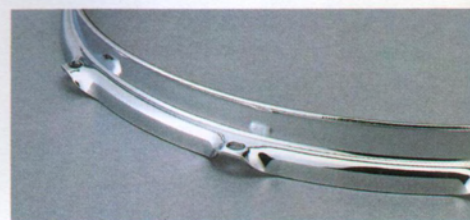

"FREE FLOATING SYSTEM" SNARE DRUMS

Pearl's "Free Floating System" is the ultimate snare drum concept. No hardware is attached to the shell. Without the sound-robbing contact of hardware and without holes, only the heads and chassis touch the shell, allowing the resonance of the shell itself to contribute to the drums maximum sound potential. Sharp attack, powerful projection, and exceptional snare response totally satisfy the discriminating players' varied needs. The system enables the player to quickly and easily change shells, allowing the drummer to match his sound to his need.

"Free Floating System" Snare Drums

Model	Size	Shell Material	Lugs	Hoops	Strainer	Finish
G-914ED	8" x 14"	Maple	10 double	Die-cast Hoops	S-011	Lacquer
G-914D	6½" x 14"	Maple	10 double	Die-cast Hoops	S-011	Lacquer
G-914	5" x 14"	Maple	10 double	Die-cast Hoops	S-011	Lacquer
B-914ED	8" x 14"	Brass	10 double	Die-cast Hoops	S-011	Brass
B-914D	6½" x 14"	Brass	10 double	Die-cast Hoops	S-011	Brass
B-914	5" x 14"	Brass	10 double	Die-cast Hoops	S-011	Brass
B-914P	3½" x 14"	Brass	10 double	Die-cast Hoops	S-011	Brass
S-814D	6½" x 14"	Steel	10 double	Super Hoops	S-011E	Chrome



"FREE FLOATING SYSTEM"



B-914D



S-814D



G-914D

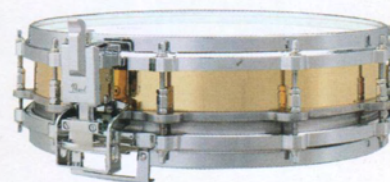

B-914P



MLX-414ED

STANDARD SNARE DRUMS

These snare drums, equipped with springless lugs, are available in shells of brass (6½" x 14"), steel (6½" x 14"), and maple (6½" x 14" and 8" x 14").

Standard Snare Drums

Model	Size	Shell Material	Lugs	Hoops	Strainer	Finish
MLX-414ED	8" x 14"	Maple	10 double	Super Hoops	S-011	Lacquer
MLX-414D	6½" x 14"	Maple	10 double	Super Hoops	S-011	Lacquer
MX-414D	6½" x 14"	Maple	10 double	Super Hoops	S-011	Covered
B-414D	6½" x 14"	Brass	10 double	Super Hoops	S-011	Brass
S-414D	6½" x 14"	Steel	10 double	Super Hoops	S-011	Chrome



MLX-414D



B-414D



S-414D

PRESTIGE ARTIST 9500 GLX SERIES

Handcrafted for the world's most discriminating artists is the Prestige Artist 9500 GLX Series. "All Maple Shells" of the highest quality are carefully lacquered and hand buffed to a gleaming lustre. Pearl's exclusive "Super Gripper" design lugs snap open for quick hoop/head removal. This series combines superb sound with the most innovative, highly functional hardware.

			PRESTIGE ARTIST 9500 GLX SERIES							
			GLX-22D-5	GLX-22D-6	GLX-22D-7	GLX-22DW-9	GLX-24D-5	GLX-24D-6	GLX-24D-7	GLX-24DW-9
Bass Drum	16" x 22"	GLX-222D	•	•	•	•	•	•	•	•
	16" x 24"	GLX-224D								
	8" x 10"	GLX-210D								
Tom Tom	10" x 12"	GLX-212D	•	•	•	•	•	•	•	•
	11" x 13"	GLX-213D	•	•	•	•	•	•	•	•
	12" x 14"	GLX-214D								
	14" x 15"	GLX-215D								
Floor Tom	16" x 16"	GLX-2116	•	•	•	•	•	•	•	•
	16" x 18"	GLX-2118								
Snare Drum	6 1/2" x 14"	B-714DX	•	•	•	•	•	•	•	
Hi-Hat Stand	H-900									
Snare Drum Stand	S-900W		•	•	•	•	•	•	•	
Cymbal Stand	C-800W		•	•	•	•	•	•	•	
Cymbal Boom Stand	B-800W				•	•	•	•	•	
Foot Pedal	P-880		•	•	•	•	•	•	•	
Tom Holder	TH-95		•	•	•	•	•	•	•	
	TH-95S									
Adaptor	AX-20		•	•	•	•	•	•	•	

Cymbals not included

Bass Drums		Floor Toms		Tom Toms	
16" x 22"	GLX-222D	16" x 16"	GLX-2116	11" x 13"	GLX-213D
16" x 24"	GLX-224D	16" x 18"	GLX-2118	12" x 14"	GLX-214D
14" x 20"	GLX-220			14" x 15"	GLX-215D
14" x 22"	GLX-222	8" x 8"	GLX-208D	8" x 12"	GLX-212
14" x 24"	GLX-224	8" x 10"	GLX-210D	9" x 13"	GLX-213
		10" x 12"	GLX-212D	10" x 14"	GLX-214
				12" x 15"	GLX-215

SUPER GRIPPER (Pat. Pend. U.S.A. and Japan)

Pearl's exclusive "Super Gripper" is an innovation in lug construction. Its springless design eliminates rattle, and a special EVA plastic tubing inside the casing "grips" the rod to keep it from loosening due to vibrations. To change heads, just loosen the tension rods a few turns and snap open the lugs. There's no need to remove tension rods or washers.





GLX-22DW-9 Illustrated in No.103 Piano Black Cymbals not included

B-714DX

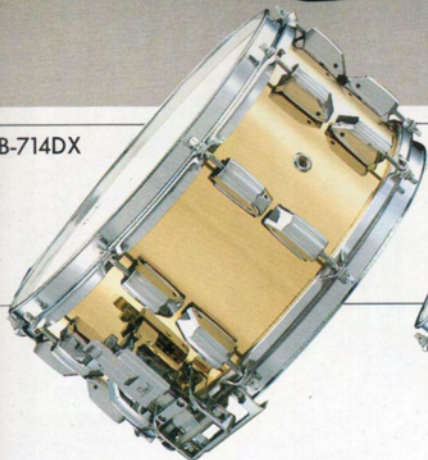

G-714DX

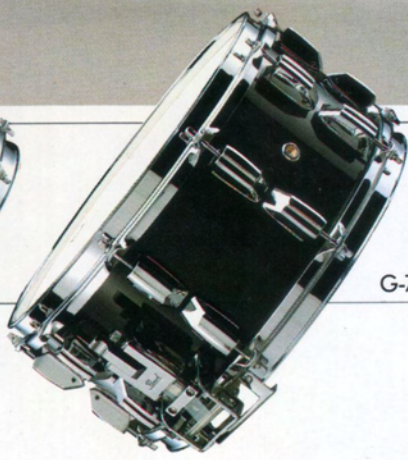

"SUPER GRIPPER" SNARE DRUMS

Three snare drums are available with "Super Gripper" lugs. The bright and powerful sounding B-714DX, 6½" x 14", brass shell drum is the standard for GLX kits. The rich, resonant maple shell G-714EDX, 8" x 14", and G-714DX, 6½" x 14", are also available for use with any kit.

"Super Gripper" Snare Drums

Model	Size	Shell Material	Lugs	Hoops	Strainer	Finish
G-714EDX	8" x 14"	Maple	20 single	Super Hoops	S-011	Lacquer
G-714DX	6½" x 14"	Maple	20 single	Super Hoops	S-011	Lacquer
B-714DX	6½" x 14"	Brass	20 single	Super Hoops	S-011	Brass



Tommy Lee/Mötley Crüe



Tico Torres/Bon Jovi



Chester Thompson/Genesis



Jeff Porcaro/TOTO



Larrie Londin/Studio



Mike Baird/Journey



Rikki Rockett/Poison



Keni Richards/Autograph



Bobby Daniels/Kenny Rogers



Sterling Campbell/Cyndi Lauper



Kelly Keagy/Night Ranger



Tris Imboden/Al Jarreau

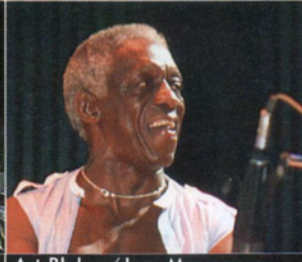

Art Blakey/Jazz Messengers



Mino Cinelu/Studio



Dwain Miller/Keel

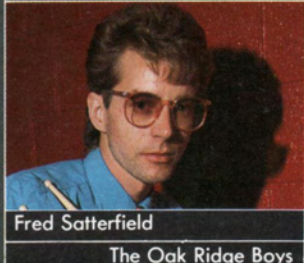

Fred Satterfield
The Oak Ridge Boys



Mel Lewis/Mel Lewis Orchestra



Alan Kerr/Ronnie Milsap



Joe Smyth/Sawyer Brown



Richie Morales/Spyro Gyra

John Molo/Bruce Hornsby & The Range
Ken Mary/Alice Cooper
Moyes Lucas, Jr./Jeffrey Osborne
Dave Palmer/Paul Young
Jim Brown/UB40
Glen Symmonds/Eddie Money

Martin Drew/Oscar Peterson
Woody Geissman/The Del Fuegos
Dennis Chambers/Special EFX, John Schofield
Keith Knudsen/Southern Pacific
Bill Maxwell/Koinonia
Roger Hawkins/Studio
Michael Kowalski/The Beach Boys
Bobby Figueroa/The Beach Boys

Kenwood Dennard/Gil Evans
Les DeMerle/Transfusion
Bud Harner/Barry Manilow
Mark Stevens/Studio
John Dittrich/Restless Hearts
Greg Dotson/Earl Thomas Conley
Kenny Jo Silva/John Cafferty & The Beaver Brown Band
Greg Thomas/The Byrds

Gary Mallaber/Steve Miller
Tony Newman/Crystal Gale
Barrett Deems/Rhythmakers
Shannon Ford/The Gatlin Brothers
James Stroud/Studio
Eddie Zyne/The Monkees
Ron Hurst/Steppenwolf

THE PEARL FORCE



Steve Ferrone/Duran Duran



Fred Coury/Cinderella



Alan Jackman/The Outfield



Michael Hanson/Glass Tiger



Donny Baldwin/Starship



Munetaka Higuchi/Loudness



Bill Marshall/Hank Williams Jr & The Bama Band



Carmine Appice
King Kobra/Vanilla Fudge



Jack Bruno/Tina Turner



Jon Farriss/INXS



Ian Paice/Deep Purple



Frankie Banali/Quiet Riot



Mark Brzezicki/Big Country

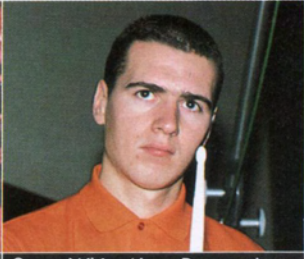

Steve White/Jazz Renegades

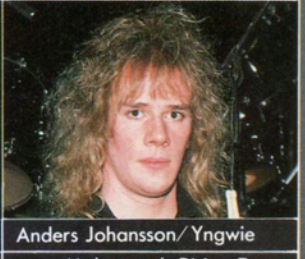

Anders Johansson/Yngwie
Malmsteen's Rising Force



Tony "Thunder" Smith
Independent

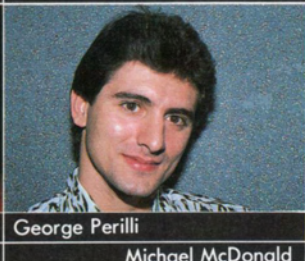

George Perilli
Michael McDonald



Chris Slade/The Firm

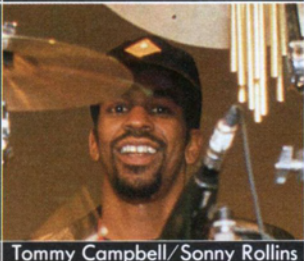

Tommy Campbell/Sonny Rollins



Chuck Bürgi/Meatloaf

Simon Kirke/Bad Company
Greg Morrow/De Garmo & Key
Sammy Creason/Kris Kristofferson
Biff Adam/Merle Haggard
Butch McDade/Roy Clark
Eric Singer/Gary Moore
Jimmy Hyde/Eddie Rabbitt
Marvin Smith/Dave Holland Quintet

Narada Michael Walden/Studio
Trevor Murrel/Five Star
Zak Starkey
Martin Parker/Independent
Jim Blair/Animation
Doane Perry/Jethro Tull
Trevor Gale/Independent
Phillip Fajardo/Independent

Dan Atherton/Atlantic Starr
Tom Reeves/The Imperials
Michael White/Frankie Beverly & Maze
Billy Hart/Independent
Brian Pastria/Adrenaline
Betram Engel/Peter Muffy
Rolf Brendel/Nena
Jurgen Zöller

Armin Rühl
Christophe Deschamps
Cesar Zuiderwijk/Golden Earring
Fred Hoogendoorn
Jos Zoomer/Vandenberg
Manuel Costa Reis

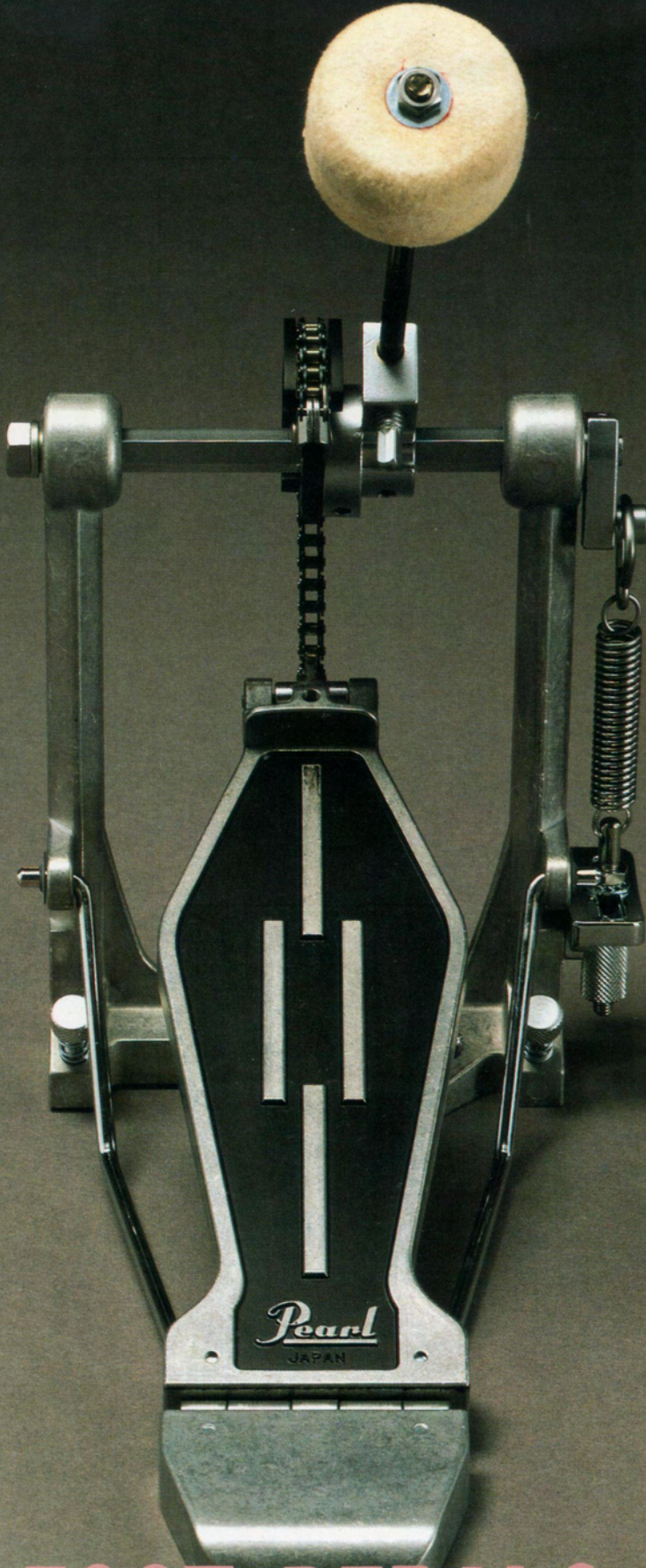

FOOT PEDALS

P-880 Pearl's exclusive "Chain Drive Wheel System" featuring a sprocketless design which allows smooth wheel action and eliminates noise. Designed for perfect balance, the chain drive wheel combined with the aluminum die-cast footboard delivers maximum speed and control.



P-750 The P-750 is a version of the P-800. By adapting the wheel drive action system, the P-750 uses the same concepts and also utilizes a durable stretch-proof strap for speedy footwork.

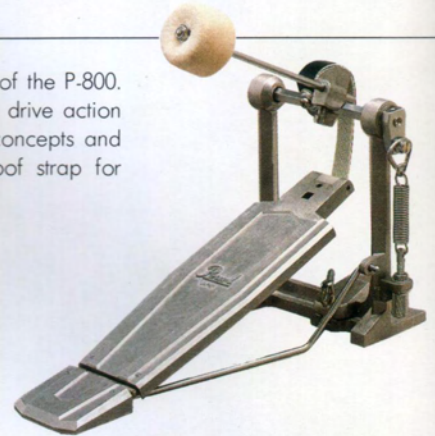

DRIVE ACTION

P-880 (and P-880TW) The transfer of energy from the footboard to the beater ball is achieved with Pearl's exclusive "Chain Drive Wheel Action" system. Featuring a felt-lined molded channel, this system eliminates both noise and the possibility of chain slippage.

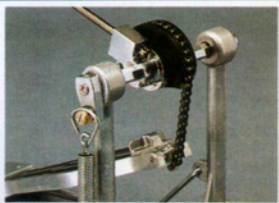

P-850 (and P-850TW) "Chain Drive Action" with sprocket. By regulating the turning radius of the sprocket at a fixed point, the foot action is smooth, easy and natural.



P-800 The P-800 is a full wheel drive action pedal, with the drive shaft running through the center of the wheel.

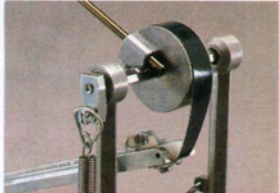

P-750 Speedy footwork is attained with the P-750 through the use of a durable stretch-proof strap and partial wheel drive segment.

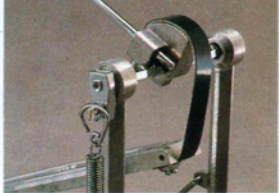

P-850 The P-850 chain/sprocket foot pedal utilizes felt inserts in the spring to eliminate noise. Free adjustment of the beater angle is achieved without affecting spring tension. The specially designed lightweight footboard is the same as with the P-880.

Note: P-850 is not available in U.S.A.



P-800 The P-800 features the original "wheel drive action" system, a beater angle that can be adjusted without affecting spring tension, and a strap design to achieve quiet and fast action.

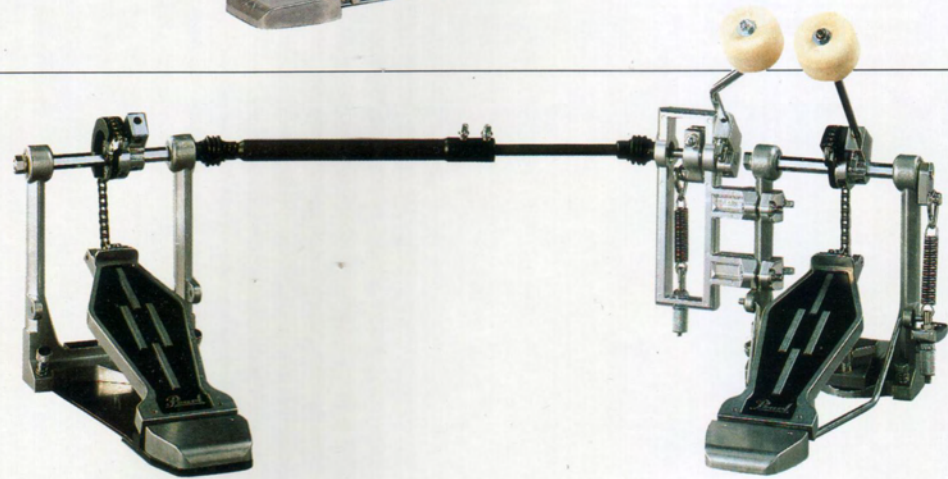
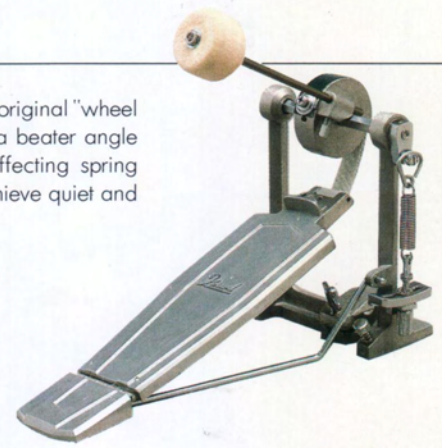

P-880TW (Shown with P-880) The P-880TW is Pearl's exclusive "Chain Drive Wheel Action" twin bass drum pedal. With two universal joints and one telescopic adjustment joint, the P-880 pedal may be connected to many single Pearl pedals. The beater angle adjustment cam (Pat. Pend.) allows adjustment to many beater angles without affecting spring tension. The P-880TW connects to other pedals with a post clamp. (Pat. Pend.). Also available for "left-handed" drummers as model P-880TWL.

P-850TW (Shown with P-850) The P-850TW is a "Chain Drive Twin Pedal", utilizing a chain and sprocket. Beater angle adjustment cam, and all other specifications are the same as with the P-880TW. Note: P-850TW is not available in U.S.A.

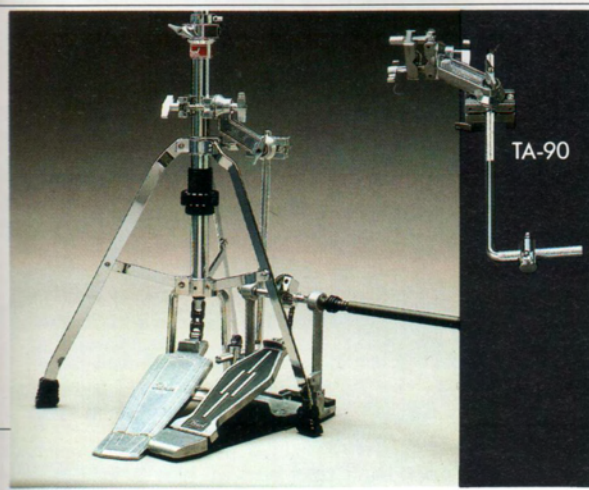
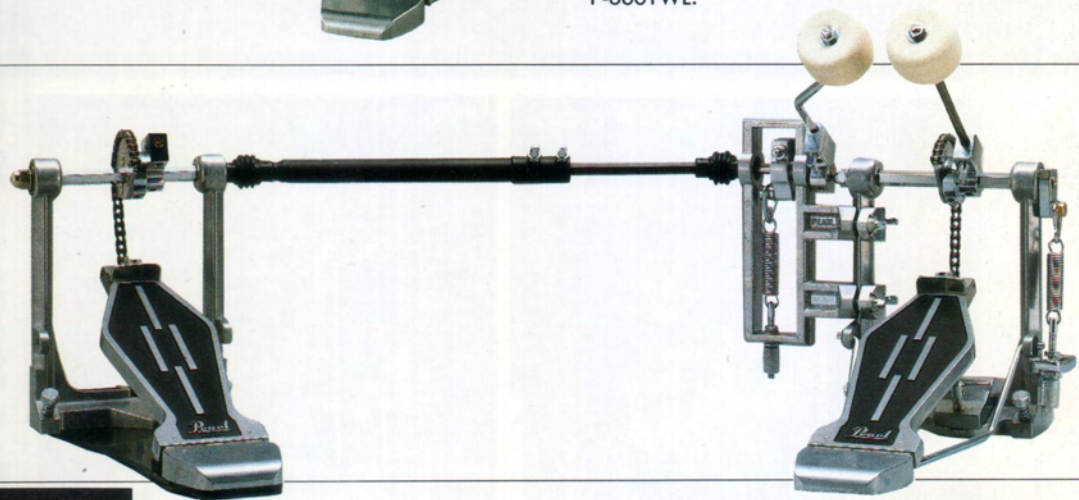

TWIN PEDAL ATTACHMENT

By connecting the twin pedal (P-880TW or P-850 TW) to the hi-hat with a TA-90, the pedal is effectively stabilized.

TA-90

BASS DRUM BEATERS

- B-150DB — Wood ball beater
- B-150BB — Felt ball beater for P-880, P-850, and P-800
- B-150C — Felt ball beater for P-750
- B-150CR — Felt ball beater (Crankshaft) for P-880TW and P-850TW

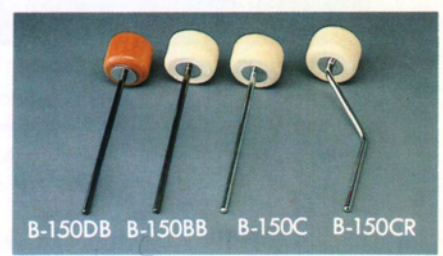



TOM HOLDERS



TH-95

TH-95S

TH-95/TH-95S

Pearl's TH-95 and TH-95S, patented tom holder arms, can be securely adjusted to any desired angle. A concealed ring brake mechanism securely locks the arm with Pearl's exclusive "Uni-Lock" system at any angle. The TH-95 has extra length for mounting toms on the bass drum, while the TH-95S is for use with adaptors on twin tom or cymbal stands.



TH-80

TH-80S

TH-80/TH-80S

These models have the same 7/8" pipe diameter as the TH-95/TH-95S. The arm locks to the desired angle with a concealed deep gear system. The TH-80 is for bass drum mounting, and the TH-80S is for use with adaptors on twin tom or cymbal stands.

CYMBAL HOLDERS

CH-90L/CH-90/CH-80

Model CH-90L and CH-90 feature Pearl's positive "Uni-lock" system on the tilter. The CH-90L has a longer boom with a weight to counter balance large cymbals, while the CH-90 is a mini boom. The boom arm clamp has a gear mechanism which allows cymbal positioning at any angle and provides stability for heavier cymbals. Model CH-80 is an adaptation of the B-700 cymbal boom stand and has a geared tilter angle section.

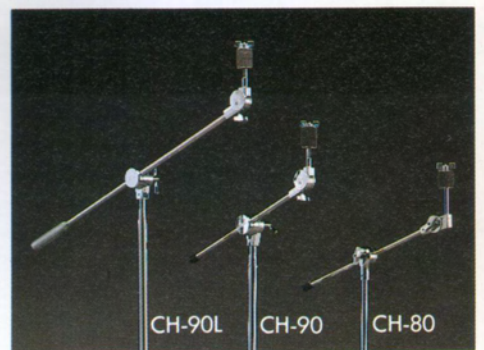

CH-90L

CH-90

CH-80

Pearl's technology plus Jeff Porcaro's original design Produced an innovation in drum kit setup—the DR-1 drum rack. Player designed, this rugged rack facilitates quick and efficient setup of the drum kit every time. Both the DR-1 and DR-2 racks are designed to be folded compactly, with clamps in place, for quick and easy reassembly. Lightweight aluminum posts with sturdy 4mm thick steel joints withstand the heaviest setups.

DRUM RACKS

(Patented)

The DR-1 and DR-2 are collapsible and come equipped with 4 PC-1 clamps.

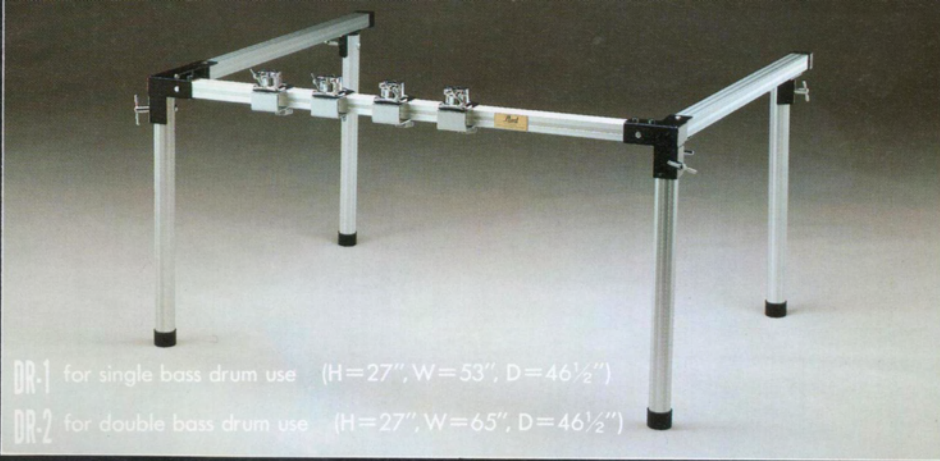

DR-1 for single bass drum use (H=27", W=53", D=46½")

DR-2 for double bass drum use (H=27", W=65", D=46½")

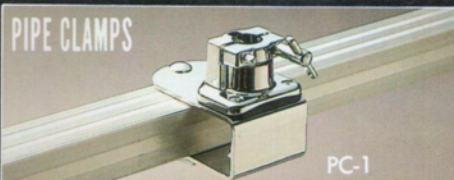

PIPE CLAMPS

PC-1

The PC-1 accepts Pearl's common 7/8" pipes used on tom, cymbal, and cowbell holders as well as the upper sections of 800 and 900 series cymbal stands.



HI-HAT ATTACHMENT

HA-80

The HA-80, in combination with PC-2 clamp, is used to securely connect a hi-hat stand to the drum rack.

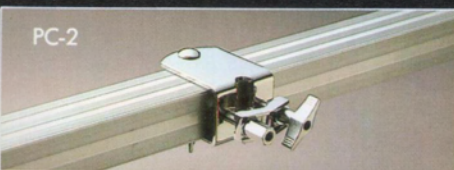

PC-2

An optional accessory to either rack, the PC-2 is adjustable to accept any lightweight pipe. Used with the MH-80, microphones are easily mounted.



MICROPHONE HOLDERS

MH-80S

MH-80L

Available with long and short boom arms, microphone setting at any position and angle is possible with these holders.



COWBELL HOLDER

73XN

Through use of a gear system, the cowbell can be tilted to any angle. The pipe diameter is Pearl's 7/8" standard.

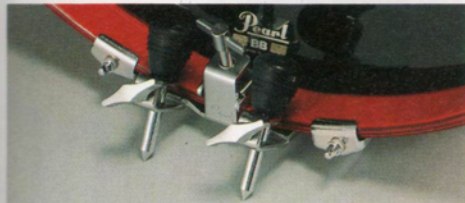

BASS DRUM ANCHOR

721

After clamping onto the front bass drum hoop, the reversible rubber/spike tip eliminates bass drum creep.

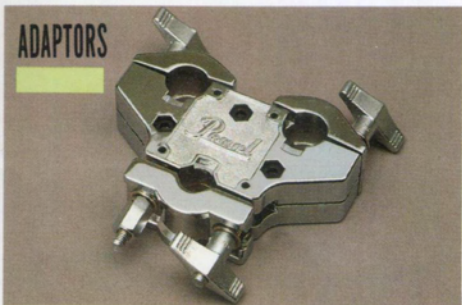

ADAPTORS

AX-30

Having heavy-duty design, two of the three-holes accept Pearl's 7/8 inch pipe diameters, and the third hole will accept pipe diameters of 5/8 inch to 1 and 1/8 inch, providing greater flexibility in accessory choices.

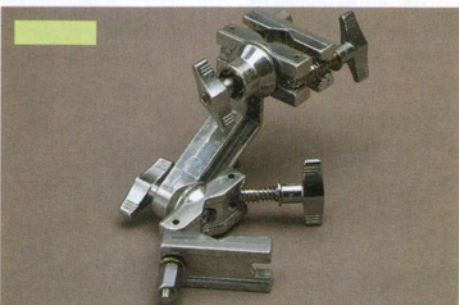

AX-25

An expanded version of the AX-20. The two gear system clamp sections revolve 360°, enabling you to set any holder at whatever angle you wish.

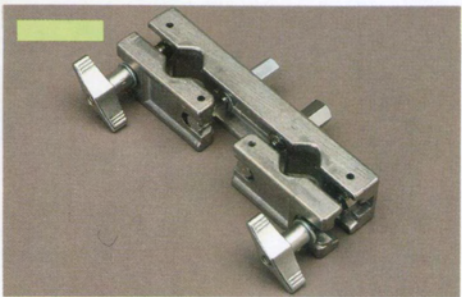

AX-20

This two-holed, compact, aluminum die-cast adaptor, being slightly enlarged for ease in set-up, firmly grips tubing from 5/8 to 1 and 1/8 inch in diameter.



STOP LOCK

SX-2

This die-cast lock has upper and lower tabs to assure fast tom placement in the exact position you want—every time. Interchangeable for right or left hand use.



H-900 The H-900 has a dual spring mechanism for wide spectrum tension adjustment. A triple-lock Hi-Hat Clutch (Patented) allows you to control the amount of felt contact and pressure on the top hi-hat cymbal. Each leg has its own reversible tip (Pat. Pend.) giving you the choice of either rubber or a spike to insure non-skid stability on any surface.

H-800W/H-800 Another "direct-pull" hi-hat, the spring tension adjustment is achieved through the use of a large plastic knob within easy reach of the player, permitting smooth, positive tension adjustment. The H-800W has heavy duty double-braced legs. The H-800 features single braced legs.

H-700 The H-700, also a "Direct-Pull" hi-hat stand is unique in its class for fast, and smooth action.

HI-HAT ATTACHMENT

The HA-95 is a heavy duty clamp system, used in conjunction with the AX-25 adaptor. Workable with any Pearl hi-hat stand, it's a necessity for twin bass drum players.

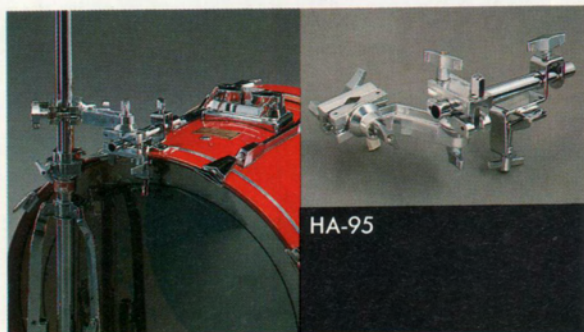

HA-95

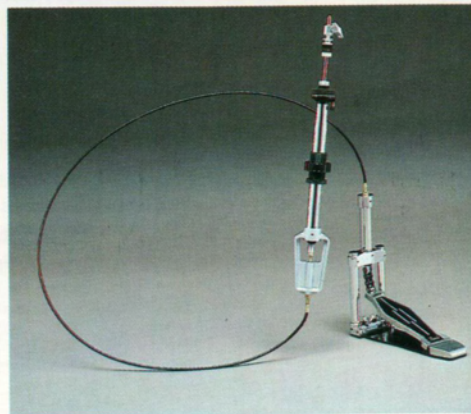

HI-HAT STANDS

REMOTE HAT

RH-800

The RH-800 Remote Hat eliminates the restrictions of conventional hi-hat positioning, thus making the hi-hat easier to play. The cable, made of damage and strain-resistant material, provides smooth action due to the Teflon risin that coats the inside of the casing. With the AX-25 adaptor, the RH-800 can be set at any desired position and angle... even upside down!

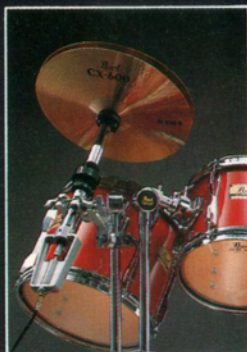

NYLON BUSHING JOINTS (H-900/H-800W/H-800/H-700)

A smooth and secure mechanism and the stop-lock which "remembers" any desired height setting.

REVERSIBLE TIP (Revolving Stopper) on H-900

A choice of a rubber or spike tip is available through the use of a drum key.

CHAIN STRAP (H-900/H-800W/H-800/H-700)

A chain strap is used on all models for durability and quick, positive response.

FOOTBOARD

This footboard design permits smoother, faster action.

TRIPLE-LOCK HI-HAT CLUTCH (Patented) on H-900 HI-HAT STANDS

With a touch, three positioning points are securely locked with Pearl's original mechanism.

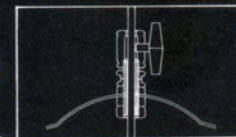

HI-HAT CUP (H-900/H-800W/H-800/H-700)

Features a large cup with thick and flexible felt which receives the bottom cymbal.

DUAL SPRING MECHANISM (H-900)

By the use of two sets of springs, delicate tension adjustment is possible, and the benefits of the direct pull mechanism can be fully realized.

SPRING TENSION ADJUSTMENT (H-800W/H-800)

A wide range of spring adjustments are achieved with the large plastic knob positioned within easy reach of the player.

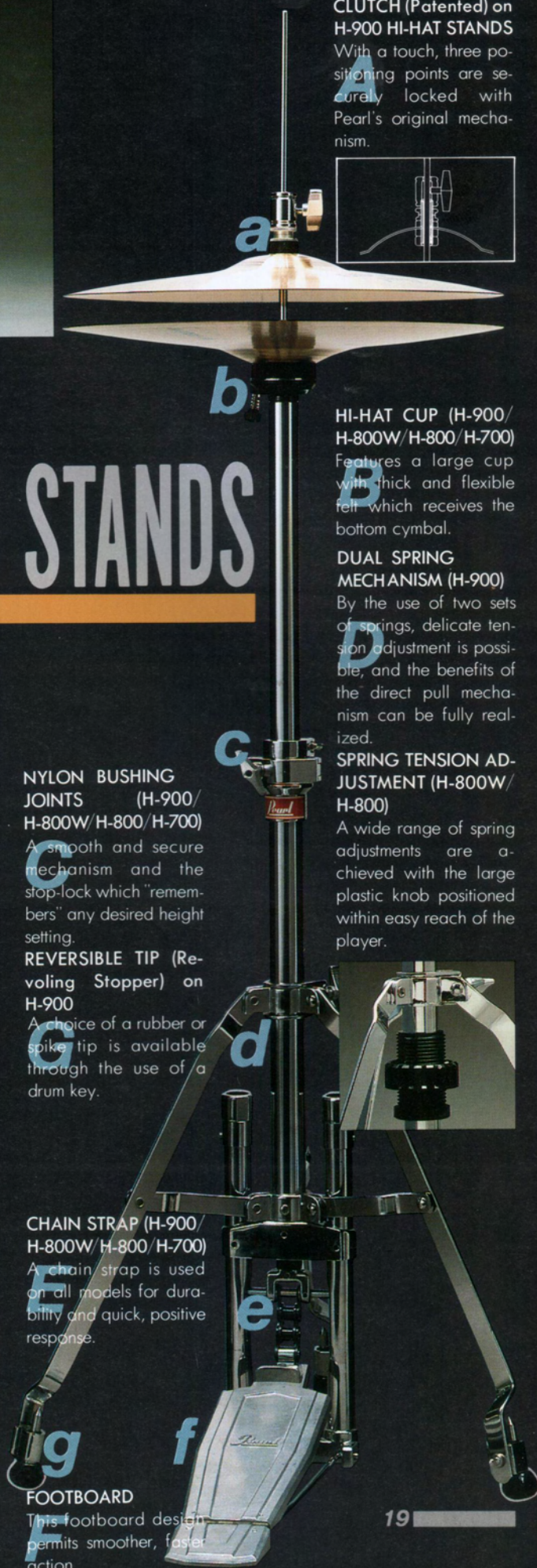

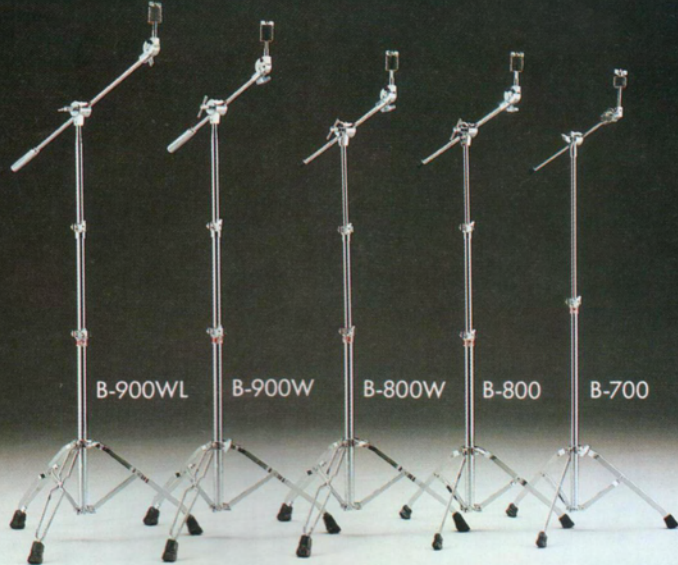

B-900WL/B-900W

B-900 boom stands feature the "Uni-Lock" System Cymbal Tilters (Patented), and maximum strength to hold even the heaviest cymbals. The longer boom arm for the B-900WL and the short boom arm for the B-900W are both equipped with heavy counter weights and have double braced leg construction. The longer boom on the B-900WL is positively secured at the vertical junction for no-twist setup. The B-900W features a conventional shorter boom.

B-800W/B-800

The B-800 series cymbal boom stand is a lighter series. The Uni-Lock system cymbal tilter is used with unweighted booms. The B-800W with double braced legs and the B-800 with single braced legs are well balanced with wide stance capability to meet most playing needs.

B-700

The B-700 is a light, compact, two-stage boom stand. A gear system cymbal tilter is used.



C-900W

The C-900 features maximum tube diameter and wall thickness needed to hold the heaviest cymbal. It demonstrates superb stability for high-energy cymbal playing.

C-800W/C-800

C-800 series cymbal stands are perfectly balanced with wide stance capability to satisfy most playing needs. The C-800W has double braced legs, and the C-800 has single braced legs.

C-700

Compactness and simplicity as well as durability and playability offer professional quality and function. A gear system cymbal tilter is featured.

CYMBAL BOOM STANDS CYMBAL STANDS

**UNI-LOCK SYSTEM
CYMBAL TILTER (Pa-
tented) on 900/800
SERIES**

A concealed ring brake mechanism achieves smooth, solid locking of the tilter with just one touch, and enables the cymbal to be set at any angle. The offset tilter allows compact storage.

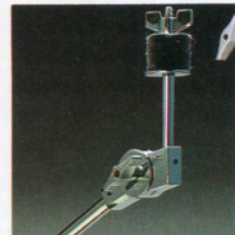

**GEAR CYMBAL TILTER
(700 series)**

The gear cymbal tilter provides excellent playability and durability. Also features an offset tilter.

**BOOM TILTER (900/
800 series)**

The length, angle, and rotation of the boom arm is positioned at a touch.

**NYLON BUSHING
JOINT (900/800/700
series)**

Pearl's innovative joint system utilizes a nylon bushing around the pipe for maximum holding power and elimination of over tightening.



d

RUBBER TIP

Pearl's large, durable, rubber tip allows stability at any angle to the floor.

ARM SLEEVE COVER (S-900W/ S-800W/ S-800)

Durable, large EVA plastic arm sleeves allow extra grip, and the material's elasticity helps absorb vibration.

UNIVERSAL ANGLE ADJUSTMENT (Patented) on S-900W

An innovative system for attaining universal angles

ANGLE ADJUSTMENT (S-800W/S-800)

Features a modified Uni-Lock system that enables stepless angle adjustment for the snare drum.

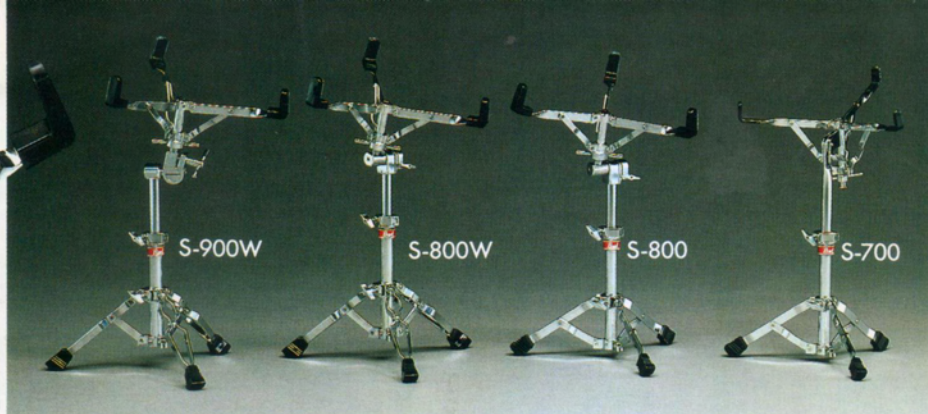
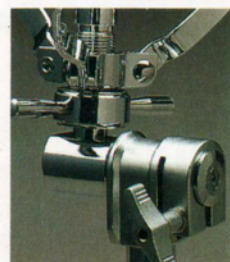

S-900W Pearl's exclusive "Universal Angle Adjustment" (Patented) system is utilized for total angle settings and solid one-touch locking. The tripod features double braced legs with a wide stance for stability and safety.

S-800W/S-800 The angle adjustment is achieved with a modified Uni-Lock system. The S-800W features heavy duty double braced legs while the S-800 has single braced legs.

S-700 Light and compact, the S-700 achieves stability through its low center of gravity.

SNARE DRUM STANDS

TWIN TOM TOM STANDS

T-950W Model T-950W is a heavy duty twin tom tom stand with double braced legs. Using two TH-95S tom holders with Stop Locks provides additional holding power.

T-800 Model T-800 uses two TH-80S tom holders, with Stop Locks on each tom holder arm. The stand has single braced legs with nylon bushings.



D-900 Model D-900 features a thick padded cloth-covered seat. The non-slip threaded height adjustment shaft provides adjustment at any position by tightening the steel bushing with a large "T" bolt. The seat diameter is 13", and the height can be adjusted between 485mm (19") through 700mm (27½").



DRUMMER'S THRONES



D-850 High quality, well-ventilated cloth material is used on the padded seat. With the use of the plastic bushing system plus a large stop-lock, height adjustment is easily achieved and firmly secured at any point. Height adjustment is 450mm (17¾") through 630mm (24¾").

D-730 Equipped with the same height adjustment as the D-850, this throne is a lighter weight, more compact model with double braced legs for added security. Height adjustment is 470mm (18½") through 630mm (24¾").



PRACTICE SET

The TK-5 practice set uses actual drum heads which are tunable, and it even allows rimshots. Practicing is possible without sacrificing the feel of an acoustic set. The TK-5 uses a rack concept for simple setup and compact design.



PRACTICE RUBBER PADS

Pearl's specially processed rubber pads provide a natural stick rebound. They are also an excellent mute control, giving you the opportunity to practice on your kit whenever and wherever you wish.



Model	Size
RP-10	10"
RP-12	12"
RP-13	13"
RP-14	14"
RP-16	16"

EXTERNAL MUFFLER

An effective muting device that allows free vibration of the drum head.





As the world's leading manufacturer of total percussion instruments, Pearl has also devoted its resources to the development of professional quality cymbals to complement their full line of drums. After many years of research and development, Pearl has created high quality CX-900 and WILD 900 cymbals with the sound and quality you expect from Pearl.

CYMBALS

CX-900

The CX-900 series is Pearl's prestige line. Years of development have produced cymbals of exceptionally high quality. Their unique clear tonal color blends well with any style of music. Special tempering and surface processing help prevent the familiar loss of sustain over the years of use, protecting your investment in quality sound.

WILD 900

The WILD 900 series is specifically designed to cut through! With awesome sound projection, Pearl's WILD series is made to withstand the heaviest attacks.

CX-900 SERIES

MODEL	SIZE	8"=20cm	10"=25cm	12"=30cm	14"=35cm	16"=41cm	18"=46cm	20"=51cm	22"=56cm
HEAVY RIDE								CX920HR	CX922HR
MEDIUM RIDE								CX920MR	CX922MR
HEAVY CRASH						CX916HC	CX918HC		
MEDIUM CRASH						CX916MC	CX918MC	CX920MC	
THIN CRASH						CX916TC	CX918TC		
HEAVY HI-HAT TOP					CX914HHT				
HEAVY HI-HAT BOTTOM					CX914HHB				
MEDIUM HI-HAT TOP					CX914MHT				
MEDIUM HI-HAT BOTTOM					CX914MHB				
CHINA TYPE							CX918CT	CX920CT	
SPLASH		CX908SP	CX910SP	CX912SP					

WILD 900 SERIES

MODEL	SIZE	8"=20cm	10"=25cm	14"=35cm	15"=38cm	16"=41cm	18"=46cm	20"=51cm	22"=56cm
HEAVY RIDE								W920HR	W922HR
MEDIUM RIDE								W920MR	W922MR
HEAVY CRASH						W916HC	W918HC		
MEDIUM CRASH						W916MC	W918MC	W920MC	
HEAVY HI-HAT TOP				W914HHT	W915HHT				
HEAVY HI-HAT BOTTOM				W914HHB	W915HHB				
MEDIUM HI-HAT TOP				W914MHT	W915MHT				
MEDIUM HI-HAT BOTTOM				W914MHB	W915MHB				
CHINA TYPE							W918CT	W920CT	
CHINA SPLASH		W908CSP	W910CSP						

COLOR FINISHES

		PRESTIGE ARTIST 9500	PRESTIGE CUSTOM 8500	CUSTOM 8500	PRESTIGE STUDIO 7500
No.102 NATURAL MAPLE		<input type="checkbox"/>	<input type="checkbox"/>		
No.103 PIANO BLACK		<input type="checkbox"/>	<input type="checkbox"/>		<input type="checkbox"/>
No.106 ANTIQUÉ IVORY		<input type="checkbox"/>			
No.107 CORAL RED		<input type="checkbox"/>	<input type="checkbox"/>		<input type="checkbox"/>
No.108 CHARCOAL GRAY		<input type="checkbox"/>	<input type="checkbox"/>		
No.109 ARCTIC WHITE		<input type="checkbox"/>	<input type="checkbox"/>		<input type="checkbox"/>
No.110 SEQUOIA RED		<input type="checkbox"/>	<input type="checkbox"/>		<input type="checkbox"/>
No.21 SMOKY CHROME				<input type="checkbox"/>	
No.31 JET BLACK				<input type="checkbox"/>	
No.33 PURE WHITE				<input type="checkbox"/>	
No.38 STAINLESS STEEL				<input type="checkbox"/>	
No.71 FERRARI RED				<input type="checkbox"/>	



PEARL DEALER

Pearl[®]

Specifications are subject to change without notice.
Apr. 1987 A620415 Printed in Japan