

TAMA DRUM BOOK

BILLY COBHAM



vol. 1

A SHORT HISTORY OF DRUMS & DRUMMING

struments, and many a historians believe that man's first attempts at communication had rhythmic basis. Man has an instinctive love of rhythm. He has used drums and rhythms to celebrate, to mourn, and to call to battle. And much of the force, emotion and power of music today would be lost without drums.

In its early forms the drum was either a cylinder or bowl of wood, metal or earthenware. The shell was covered at the open end or ends with some sort of membrane, usually an animal skin, and set into motion with either the hand or a stick.

Things haven't changed very much, have they?

Drums are known to have existed in ancient Sumeria nearly 3000 years before the birth of Christ, and the great variety of ways which they are employed today testifies to their long period of development. Early drums fell into three basic classifications-1) shallow drums such as the tambourine; 2) Kettledrums; and 3) tubular drums. The drums of the first two types are commonly known by specific names. The third type are the direct ancestors of drums as we use them today.

Tubular drums evolved in Asia in many different sizes, from the grain filled rattle drums of ancient China to the hourglass-shaped "tsuzumi" of Japan. In India, the drumming art developed from a base of highly complex rhythm patterns, played on barrel shaped drums. In Burma, drums were hung in chimes of two dozen or more, with each drum tuned to a definite pitch.

The cylindrical drums we know today came from the near east. The prototype of the modern snare drum was adopted from Arabic drums found in Spain and the Holy Land. At first a folk instrument, the snare became the musical badge of the infantry from about the 14th century on. The large, shallow bass drum, once known as the Turkish drum, came to Europe from the Ottoman armies as late as the 18th century, along with military cymbals and other features of the military band.



Modern orchestral drumming as we know it today, evolved about two hundred years ago, and drums were widely employed to provide instrumental color and dynamic power to music.

The modern "trap set" in its current form is less than a century old. An interesting side to drum history is the development of the drum sizes we use today.

When drums were first to be introduced as "sets" there was a very small market, as you might expect. Rather than invest in expensive molds to bend wood into perfect cylinders, the first drum manufacturers used wooden lampshades as drum shells. The lampshades were just sturdy enough, and available in enough of a variety of sizes to make them practical. Since 12, 13 and 14 inches were the most common sizes for lampshades, they immediately became to the most common sizes for drums. This size preference continues today.

So from hollowed out logs to lampshades, the history of drums spans nearly all of recorded history. As children, we could feel rhythm long before we could distinguish melody. Drums and rhythm are in our bones, and drums will always be with us.

As a manufacturer of drums, we at Tama are committed to producing the best possible percussion products we can build, with a sense of our history, a feeling for today's drummer, and an eye to the future of drums.



The mere fact that you're now reading a drum catalog, indicates that you have more than a passing interest in the world of percussion. It is interesting to note that nearly everyone loves drums and those of us who play drums have developed this love into a passion. Of all musicians, drummers are the most fanatical, dedicated, energetic, devoted, and happy. If you've ever wondered why this is so, you're not alone.

Perhaps the reason is historical. Drums are the earliest know musical in-

SHELL CONSTRUCTION

Since a drum is basically a hollow cylinder, covered at one or both ends with a membrane, there are many suitable materials from which to make drums. Man's earliest drums were made of wood and wood continues to be the most accepted material for drum construction. Many metals and chemical products were and are used to make drums and each has its own characteristics. Material selection is a source of much discussion, and even a source of bitter debate among manufacturers.

We have to keep in mind that drums are musical instruments, and as such, are evaluated in a subjective manner by each individual musician. So what sends one musician into ecstasy will send another into a fit of disgust. Here is a basic run down of the types of materials used for drums and their various characteristics.



WOOD SHELLS

Even though wood has been with us for centuries, there is still considerable variation in the type of wood, its thickness, number of layers, etc. when it comes to making drums. The most common woods used for drum construction are the North American hardwoods, basically because they are durable and plentiful. Birch, beech, maple, gum and others are used, either exclusively or in some combination. Tama Imperialstar drums are unique in that they are made of Mahogany. Mahogany has very consistent strength per unit of cross section resulting in a drum of very uniform performance.

All wood shells are laminated from several layers of wood. The number of plies varies from 4 to 9, with the most common being 6. However, a 4-ply shell is not necessarily less than half as thick as a 9-ply shell. The 4-ply shell will be made up of thicker layers than the 9-ply. So, the ply number doesn't necessarily tell the whole story.

It is theoretically possible to build a wood drum shell that would be virtually indestructible, but the tone would be thin.

On the other hand, it is also possible to build a shell of incredible resonance, but it would crack like an egg at the slightest bump. The trick is to build a strong shell that will resonate.

To obtain maximum strength from a more resonant shell, Tama uses the staggered seam principle, where weak spots in the shell are avoided by staggering the seams around the circumference of the drum.

Tama Superstar drums also feature a lacquer finish on the natural wood shell, in order to allow the shell maximum freedom of vibration. The plastic cover of most drums provides a real increase in the durability of the surface of the drum, but does tend to restrict the tone.

CHEMICAL PRODUCT SHELLS

The most common chemical product shells are fibreglass and acrylic. Since nearly every other wood product was in some way being replaced by fibreglass, sooner or later someone was going to try drums. A fibreglass drum is several times stronger than a wood drum. It is also louder, heavier and brighter sounding than wood. Because fibreglass is much more dense and much harder than wood, sound reflects very well from its surface, without the shell itself resonating to any great degree. For this reason the high frequency vibrations and overtones of the head vibration are accentuated and reinforced, resulting in a brighter tone.



Tama Fibrestar shells are made by the "hand lay up" procedure, where fibreglass cloth is placed by hand in a rotating mold. The mold is then spun at a high speed while the resin is poured, resulting in a very uniform thickness. The fibreglass/resin shell is then heat cured in the spinning mold and is removed as a complete shell.

The other common chemical product shell is acrylic. Acrylics are not as hard as fibreglass, but harder than wood. They exhibit a tone that is somewhat between fibreglass and wood, although more towards fibreglass. Their sound is bright and loud, with accentuated highs.

They also have an advantage in that they can be transparent or tinted as well as opaque. This opened a new visual world for drummers. Unfortunately, acrylic shells are quite fragile and are easily split if dropped or subjected to shocks.

SHELL CONSTRUCTION

METAL SHELLS

The most common metal shell is found on snare drums. In fact, the most common snare drum is a metal shell. Metal shells are loud and bright sounding and are stronger than any other material, but are quite heavy. Since a snare drum usually has up to 10 lugs and mounts a strainer, which is under a great deal of tension, the shell should be very strong and rigid. Metal performs extremely well in this application.

Metal shells can also feature a very consistent and sharp sound edge, which is particularly valuable for snare drums. It is important that it not "choke" when rapid, loud rolls are played, and a crisp sound edge can be of real value in this situation.

Tama metal snare drums are seamless design shells for perfect roundness and uniform shell thickness. This feature assures that the heads will fit correctly. Also when the sound edge is rolled into the drum, it will be exactly the same radius at any point on the shell. Sound edges are important on all drums, not just snares. It is important not to damage this edge while changing heads, since a severe loss of sound quality can result. All Tama sound edges are machined with care and precision to insure the proper head fit and tone

**TAMA
SUPERSTAR
SHELL**



**TAMA
IMPERIALSTAR
SHELL**



So, as you can see, drums are made of different materials for many different reasons. Tama offers you three choices in drum shells, and here's what to expect from each.

Tama Superstar - Four and six ply shells of rock maple with a natural wood finish. Specifically designed for those players who want the "woodiest" sound they can get - warm, fat and deep.

Tama Imperialstar - 9-ply mahogany shells for the warmth of wood, with the projection and volume of synthetics. Imperialstar drums have made a real name for themselves on the hard road of rock and roll as "the drums that hold up on the road".

Tama Fibrestar - The fiberglass drums with real tone. The exclusive "Black Fibreglass" construction is more resonant than most fiberglass shells, yet is as loud and durable as any.

**TAMA
FIBRESTAR
SHELL**



TAMA DRUM SPECIAL FEATURES

Tama drums and hardware have more new and unique features than any other drum line. From the major considerations of durability and tone to the fine points and details, the Tama line is designed for the drummer of today and tomorrow. Here are just a few Tama features.



Seamless Snare Drum Shell
Choice of Three Snare Strainers
PC Die-Cast Hoops



No-Spring Lugs
Tama Ambassador Drum Heads



The Original Boom Stand
2-Way Cymbal Nut



Serial Number

Nylon Bushing/Clamp
Wing Nut Hardware
Adjustments



Titan Shell Supporter
High Strength Bass Drum Hoops



Universal Tom Tom Holder
Multi-Clamp System
Key-Lock Tom Tom Holder

2-Way Spurs



One-Touch Tone Control

Brake Drum Snare Tilter
Spartan Convertible Tips



Superstar, Fibrestar, Imperialstar, One-Touch, No-Spring, Key-Lock, Spartan, Titan, Mercury, Hi-Beat, King-Beat, PC Die-Cast, Multi-Clamp are all trademarks of Tama for drums and percussion products.

TAMA SPARTAN™ STANDS



2-way convertible tips



Nylon Bushing Clamp



2-way Nylon nut 7082



Brake Drum Snare Tilter

Tama Spartan hardware is a new standard of strength and light weight. All Spartan stands feature high pressure die-cast legs for strength, light weight, wide stance and a true space age look. The Spartan Two-Way convertible tips offer you the use of either a rubber stopper or steel stage spike. Spartan stands also feature the Tama exclusive **nylon bushing clamp** for smooth, positive height adjustment and long service. Your stands will stay brand new looking for years.

The Spartan Snare Stand No.6920 features the Tama brake drum snare tilter. Unlike other snare stand tilters, the Tama brake drum doesn't use ratchet teeth or metal-to-metal contact. The Spartan snare stand can be quickly set up to any angle with just fingertip tension. A revolutionary new friction material and conical drum design combine to give you perfect stability with only fingertip pressure.

The Spartan Hi-Hat No.6925 features the new Tama contoured footboard for maximum strength and comfort. The special deep ribbed design, combined with the **Spartan Convertible tip** give you incredible stability. The special heavy duty Tama clutch won't slip and won't let your cymbals loosen while you play.

SPARTAN HARDWARE

- 6920 Snare Stand
- 6921 Short Model Cymbal Stand
- 6922 Straight Cymbal Stand
- 6924 Boom Arm Cymbal Stand
- 6925 Hi-Hat Stand
- 6926-6323 Hi-Hat Stand with Holder



SPARTAN

TAMA TITAN™ STANDS



Titan Double Legs



Nylon Bushing Clamp



Brake Drum Snare Tilter



Spring Adjustment Unit

Titan stands are the stands that revolutionized the industry. Titan hardware earned its laurels on the road with some of America's hardest playing and hardest touring bands. Titan stands are the most copied drum stands in the industry, but none of the imitations is a feature packed as the Titan line.

Tama Titan stands use double steel legs in the tripod with a wide, wide 36" span. The large diameter shafts are secured with the Tama exclusive nylon bushing/clamp that will not mar or damage the shaft. Tama also offers the only tilting cymbal stand No.6893 in the industry, for those applications where a straight stand won't do and a boom stand isn't quite right.

The Tama Titan Snare Stand No.6890 is the model of stability with the Tama brake drum tilter (Pat.Pend.) and the molded-in-place rubber tips. These tips grip the rim securely, but won't pull off and won't damage the drum.

All Tama Cymbal Stands now feature the two-way nylon cymbal nut. This nut allows you to mount your cymbals in either a free floating or rigid mount fashion by simply turning the nut upside down.

The Tama Titan Throne No.6790 not only receives plaudits from drummers, but from keyboardists and guitarists as well. the thickly padded seat is soft enough to pamper your precious posterior yet firm enough to provide adequate support without fatigue.

TAMA TITAN HARDWARE

- 6790 Drum Throne
- 6890 Snare Stand
- 6892 Straight Cymbal Stand
- 6893 Tilting Cymbal Stand
- 6894 Boom Arm Cymbal Stand
- 6895 Hi-Hat Stand

Titan

TAMA MERCURY™ & ALTAIR™ STANDS



Tama Mercury stands feature single steel legs, for those drummers who don't require super heavy duty strength. Mercury stands are as ample as any other stand on the market and are priced most reasonably.

Even at a moderate price, Mercury stands are loaded with Tama features like the nylon bushing clamp for long service and the same heavy duty cymbal tilter as the Titan And Spartan.

TAMA MERCURY HARDWARE

- 6785 Drum Throne
- 6870 Snare Stand
- 6872 Straight Cymbal Stand
- 6874 Boom Arm Cymbal Stand
with out counter weight
- 6875 Hi-Hat Stand

Mercury

Tama Altair stands use double steel legs in the tripod and thinner upright shafts than Titan, Spartan and Mercury hardware.

TAMA ALTAIR HARDWARE

- 6850 Snare Stand
- 6852 Straight Cymbal Stand
- 6854 Boom Arm Cymbal Stand
without counter weight
- 6855 Hi-Hat Stand



Altair

TAMA TOM TOM HOLDERS & STANDS



TAMA TOM TOM HOLDER

The Tama bass drum bracket will accept any Tama tom tom holder and is completely interchangeable throughout the line. Tama double headed tom toms and concert tom toms both feature the same mounting bracket and are completely interchangeable. The three dimensional adjustment of Tama tom tom holders gives you a drum set up of any angle or position.

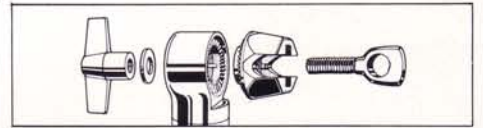

TAMA "KEY-LOCK"

A simple and effective way of giving your drum set a memory. A "Key-Lock" clamp fits on the tom tom holder and aligns with a keyway on the bass drum plate, giving you a preset height and angle.

Mini "Key-Locks" are installed on tom tom holder "L" rods and locate into keyways on the tom tom brackets. The Tama "Key-Lock" system is simple and effective, without cumbersome and expensive hardware. There are no parts that intrude into the drum shell and rob tone.

Tama tom tom holders also feature memory lines on rotating parts and interlocking teeth on the "L" rods for a rock solid mount.



DOUBLE TOM TOM STANDS

The Tama All Angle concert tom tom stand is identical to the Tama double headed tom tom stand, allowing the tom toms to be mixed in any combination. In addition, a special short stand No.6899ST is offered to allow larger tom toms to double as floor tom toms.

Tama double tom tom stands also feature the Tama exclusive Key-Lock bracket, for drum stands with a memory.

6899 Double Tom Tom Stand

6899ST Short Model Tom Tom Stand

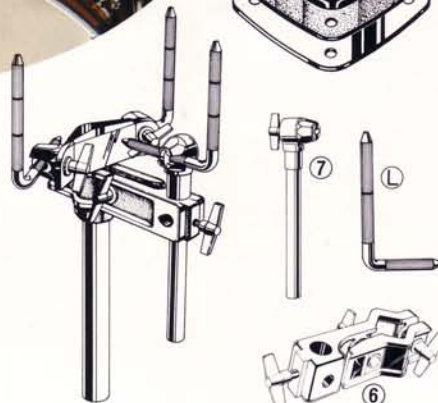

6681

Single tom tom holder, complete set.

6681-A

Single tom tom holder, less bass drum mount casting & bracket.



6682

Double tom tom holder, complete set.

6682-A

Double tom tom holder, less bass drum mount casting & brackets.



6682-3T

Triple tom tom holder, complete set.

67-L

Triple tom tom adaptor.



6660-6

Extra-Twin tom tom adaptor (Includes 6 Multi-Clamp)

TAMA BASS DRUM PEDALS

**Q:WHAT'S THE WORLD'S BEST
BASS DRUM PEDAL?**

A:YOUR OWN.

In interviews with hundreds of professional and amateur drummers around the country, we were surprised at the loyalty drummers show to their bass drum pedals. The fact is, that a once drummer becomes used to a particular pedal, that pedal becomes the best for him.

So, if you're going to get used to a drum pedal, why not make it the strongest, most adjustable and most consistent drum pedal on the market - the Tama King-Beat!

The King-Beat is one pedal that's designed to last a lifetime, and to give you consistent performance year in and year out. Just check these exclusive features.

The King-Beat is one pedal that's designed to last a lifetime, and to give you consistent performance year in and year out. Just check these exclusive features.

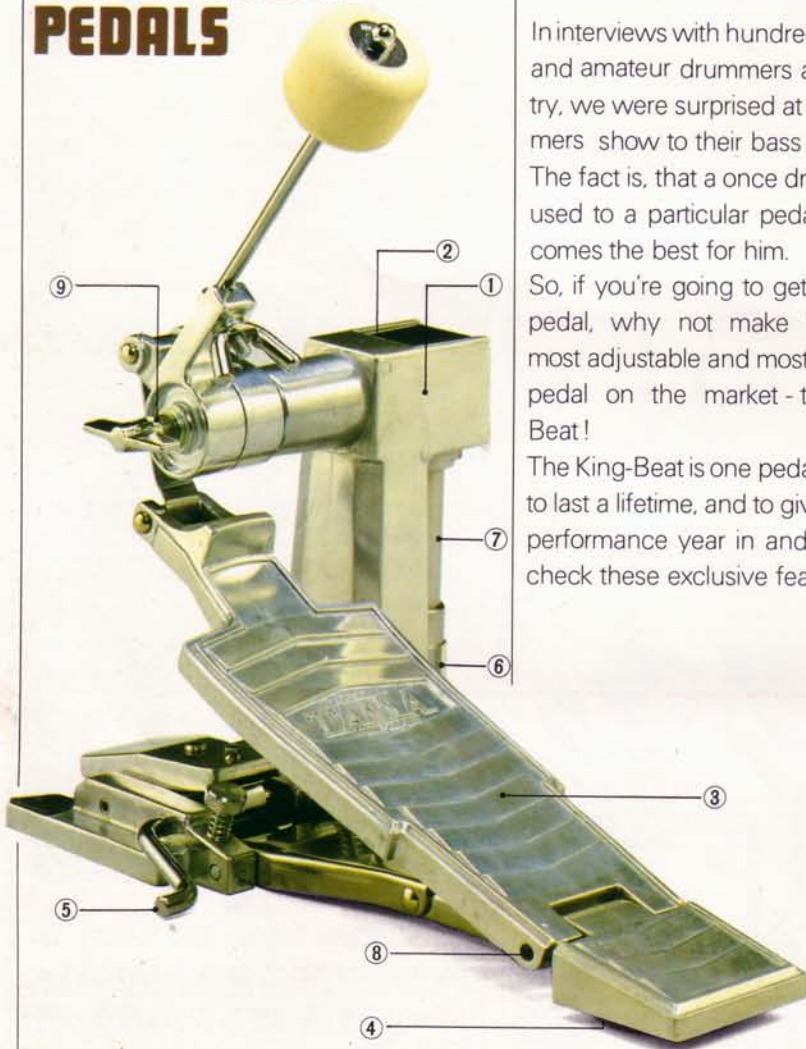

6755 KING-BEAT BASS DRUM PEDAL

- ① **Indestructable Compression Spring**- Tested to 3 million cycles without a failure.
 - ② **Cam Actuated**-The spring is actuated by a special cam for a quick positive stroke and smooth return.
 - ③ **New Design Footboard**-Heavy die-cast alloy and curved to fit the contour of your shoe.
 - ④ **Heel Height Adjustment**-To adjust the angle of the footboard independent of all other adjustments.
 - ⑤ **One-Touch Rim Clamp**-Less time to set up and break down.
 - ⑥ **Quick Spring Adjustment**-External adjustment is easy and simple.
 - ⑦ **Sealed Spring Housing**-The lubricant cannot get out and dirt cannot get in.
 - ⑧ **Nylon Pushrod Bushing**-The spring pushrod glides in a nylon bushing for smooth and quiet action for a long, long time.
 - ⑨ **Independent Stroke Angle Adjustment**-The stroke angle of the beater can be changed without changing the spring tension or the footboard angle.
- ✳ **Rugged Construction**-Built to last a lifetime, the King-Beat pedal is made almost entirely of high pressure die-cast alloy for maximum strength and light weight.

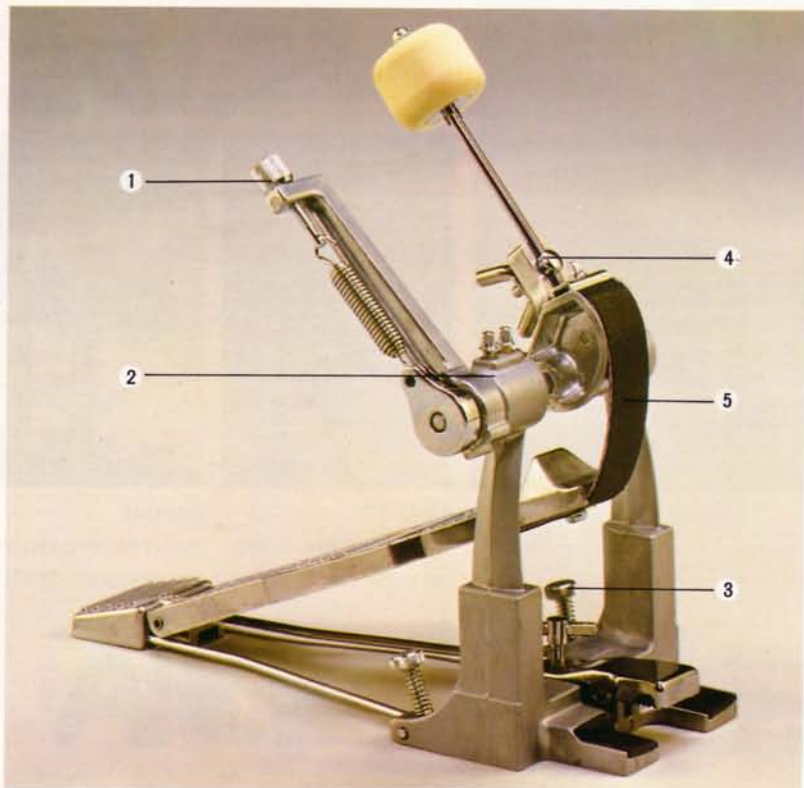

6740 HI-BEAT BASS DRUM PEDAL

The Hi-Beat pedal is a simple and straightforward pedal designed with long service and consistent action in mind. Here are just a few of its features.

- ① **Easy Spring Adjustment**-The knurled thumbscrew provides easy adjustment and the positive lock keeps it where you set it.
- ② **Adjustable Stroke Angle**-The beater stroke angle is adjustable independently of the spring tension.
- ③ **Built-In Anchors**-Help stop bass drum creep. Fully adjustable.
- ④ **Positive Beater Clamp**-Holds the beater without slipping or marring and weakening the beater shaft. Adjustable length for different bass drum sizes.
- ⑤ **Heavy Duty Cam Strap**-Specially processed and woven industrial nylon strap is many times stronger than leather. For smooth transfer of power from footboard to beater cam.

Billy Cobham



TAMA SNARE DRUMS



TAMA AC SNAPPY SNARE

One of the main contributing factors to snare drum choking is the limitation of the conventional snare. Standard snares are made from spring steel which can easily be stretched. When tightened to the point where choking is overcome, conventional snares may lose their snare effect entirely. For drummers who play hard enough and fast enough to experience this annoying symptom, the Tama AC Snare will cure the problem. The AC snare is made of high quality aircraft control cable, and will not stretch under any circumstances. Its rebound distance from the snare head is less than one-third that of conventional snares, giving it lightning response, even with moderate tension. **AC snares are available as an option only** on snare drums equipped with the Tama KG strainer.

6045 AC SNAPPY SNARE for KG strainers.



Tama snare drums are available in **three different shell materials, three different snare strainers and two different shell depths**. No matter what type of sound and response you're looking for, you can find it in the Tama snare drum lineup. All Tama snare drums feature many exclusive Tama features. Here are a few:

TAMA PC DIE-CAST HOOPS

Tama "PC" high pressure die-cast alloy hoops have many advantages over conventional hoops. All Tama snare drums feature the PC hoop to assure a perfect fit to both the drum head and shell. PC hoops won't flex the way conventional stamped hoops will, so tuning and head tension are more consistent and accurate all the way around the drum. And because Tama PC hoops are solid and warp-free, rim shots are bigger, crisper and cleaner than ever before.

ONE-TOUCH TONE CONTROL

The Tama One-Touch tone control has brought raves from drummers everywhere. The exact amount of tone control you desire can be preset and then brought in and out on cue—precise and accurate every time.

CHOICE OF SNARE STRAINER

No snare strainer can satisfy the needs of every drummer, so Tama offers you three specially engineered snare strainers from which to choose.

The Tama **KG** parallel action snare strainer offers the finest adjustment over the widest range of any strainer available. It features separate control over snare tension and head pressure. Snare operation is exactly parallel to the head surface and there are no strings or tabs to stretch or break.

The Tama **CL** compound lever strainer is a rugged die-cast unit that provides accurate fine tuning and quick positive action particularly when using extra wide snares.

The Tama **SS** compact lever strainer puts the tension adjustment and on/off lever on the same side of the drum. The SS strainer is a simple and functional design that will fit the needs of most drummers.

TAMA SNARE DRUMS



8075 5" x 14"
Tama Ambassador heads
Lever Strainer
PC Die-Cast Hoops
One-Touch Tone Control
Seamless Metal Shell
20-Strand Snappy Snare



8045 5" x 14"
8046 6 1/2" x 14"
Tama Ambassador heads
Compound Lever Strainer
PC Die-Cast Hoops
One-Touch Tone Control
Seamless Metal Shell
30-Strand Snappy Snare



8005 5" x 14"
8006 6 1/2" x 14"
Tama Ambassador heads
Parallel Action Strainer
PC Die-Cast Hoops
Seamless Metal Shell



9675 5" x 14"
9676 6 1/2" x 14"
Lever Strainer
PC Die-Cast Hoops
One-Touch Tone Control
20-Strand Snappy Snare



9605 5" x 14"
9606 6 1/2" x 14"
Parallel Action Strainer
PC Die-Cast Hoops
One-Touch Tone Control



9275 5" x 14"
Lever Strainer
PC Die-Cast Hoops
One-Touch Tone Control
20-Strand Snappy Snare



9245 5" x 14"
Compound Lever Strainer
PC Die-Cast Hoops
One-Touch Tone Control
30-Strand Snappy Snare



9205 5" x 14"
9206 6 1/2" x 14"
Parallel Action Strainer
PC Die-Cast Hoops
One-Touch Tone Control

TAMA METAL SHELL SNARE DRUM

Tama Metal snare drums feature a **seamless metal shell** for the best metal snare drum performance. The seamless shells are constructed by a special process which assures a perfectly round shell every time. Your drum heads will fit perfectly and will be easier to tune and keep in tune. The uniform thickness of Tama shells gives you a consistency of sound you'll have to hear to believe. Tama Seamless shell snare drums have a warm and fat sound that won't break up or choke even in the fastest, loudest rolls. The inner flanges of the shell are set at a perfect 45° angle for added strength and increased acoustic response particularly when playing near the edge of the head. And speaking of acoustic response, the shell edges are formed with a mere 2 millimeter radius giving the heads almost unlimited freedom of vibration.

TAMA WOOD SHELL SNARE DRUM

There is a great shift back to the original wood sound of drums these days, particularly among studio players. **Tama wood shell snare drums** offer that warm wood sound with up-to-date features and hardware that make them practical for nearly any application.

The shells themselves are made in a special way that gives them the strength of laminated wood and the vibration properties of solid wood. Tama wood shell snares have captured the mellow sound of wood without sacrificing strength and durability.

TAMA FIBREGLASS SHELL SNARE DRUMS

Tama Fibrestar snare drums feature the **Tama "Black Fibreglass"** shell for amazing strength. The heavy fibreglass shell provides a bright, loud tone, excellent for high volume music. Combined with **Tama PC die-cast** hoops, the Fibrestar snare drum is one of the cleanest and fattest fibreglass snare drums on the market.

TAMA SUPERSTAR OUTFITS



Billy Cobham

Tama Superstar-today's wood drum. Made of select and cured rock maple and birch in a special "Heat Compression" mold, Superstar drums have the strength and durability to hold up to the road. And they've got a sound and volume not common to wood drums.

Listen to what Billy Cobham has to say about his Superstar drums. "I've long been looking for a wood drum with enough power and tone for my application, and finally, I found it- **Tama Superstar**.

There's something inherently beautiful and instinctively pleasing about the sound of wood drums, after all they've been with us for thousands of years. But until now, I haven't been able to find that tone in a drum that can take it."



In addition to the Heat Compression process, all the seams in Tama Superstar drums are staggered around the perimeter of the shell to avoid any weak spots.

Combined with the strongest hardware in the business, Tama Superstar drums can give you the best of both world-tone and strength.

Superstar drums are available in natural or stain lacquer finishes or in Platina for a more roadworthy finish.

Spartan, Titan, or Mercury hardware is available with Superstar sets so you can personalize your drum kit to your taste and budget.

The Superstar sets illustrated here begin with modest outfits and progress to the more complex. These outfit suggestions are a result of the preferences you have shown for relative drum size. But you need not feel limited by what we show you here. You may order individual drums and hardware to customize your own set.



SUPERSTAR 9

OUTFIT No.9689

- 9622 14" x 22" Bass drums (2)
- 6682 Double tom tom holders (2)
- 8005 5" x 14" **King-Beat** Snare drum
- 9612 8" x 12" Tom tom
- 9613 9" x 13" Tom tom
- 9614 10" x 14" Tom tom
- 9615 12" x 15" Tom tom
- 9636 16" x 16" Floor tom tom
- 9638 16" x 18" Floor tom tom
- 6920 **Spartan** Snare stand
- 6922 **Spartan** Cymbal stands (2)
- 6925 **Spartan** Hi-Hat stand
- 6755 **King-Beat** Drum pedals (2)
- 5B Drum sticks

Cymbals not included.
Finish shown: **Natural Maple**

TAMA SUPERSTAR OUTFITS



SUPERSTAR 8

OUTFIT No.9688

- 9624 14" x 24" Bass drum
- 6682 Double tom tom holder
- 8005 5" x 14" **King-Beat** Snare drum
- 9612 8" x 12" Tom tom
- 9613 9" x 13" Tom tom
- 9614 10" x 14" Tom tom
- 9615 12" x 15" Tom tom
- 9636 16" x 16" Floor tom tom
- 9638 16" x 18" Floor tom tom

- 6920 **Spartan** Snare stand
- 6922 **Spartan** Cymbal stands (2)
- 6925 **Spartan** Hi-hat stand
- 6899 **Titan** Double tom tom stand
- 6755 **King-Beat** Drum pedal
- 5B Drum Sticks

Cymbals not included.

Finish shown : Natural Maple



SUPERSTAR 4

OUTFIT No.9684

Same as 9685 outfit, but less 12" tom tom, and with 6681 single tom tom holder.

Cymbals not included.

Finish shown : Natural Maple



SUPERSTAR 5

OUTFIT No.9685

- 9622 14" x 22" Bass drum
- 6682 Double tom tom holder
- 8005 5" x 14" **King-Beat** Snare drum
- 9612 8" x 12" Tom tom
- 9613 9" x 13" Tom tom
- 9636 16" x 16" Floor tom tom

- 6920 **Spartan** Snare stand
- 6922 **Spartan** Cymbal stands (2)
- 6925 **Spartan** Hi-hat stand
- 6755 **King-Beat** Drum pedal
- 5B Drum sticks

TAMA SUPERSTAR OUTFITS

SUPERSTAR 10C

OUTFIT No.9680

- 9622 14" x 22" Bass drum
- 6682 Double tom tom holder
- 8005 5" x 14" King-Beat Snare drum
- 9658 5-1/2" x 8" Concert tom tom
- 9660 6-1/2" x 10" Concert tom tom
- 9662 8" x 12" Concert tom tom
- 9663 9" x 13" Concert tom tom
- 9664 10" x 14" Concert tom tom
- 9665 12" x 15" Concert tom tom
- 9636 16" x 16" Floor tom tom
- 9638 16" x 18" Floor tom tom

- 6920 Spartan Snare stand
- 6922 Spartan Cymbal stands (3)
- 6925 Spartan Hi-hat stand
- 6899 Titan Double tom tom stands (2)
- 6755 King-Beat Drum pedal
- 5B Drum sticks

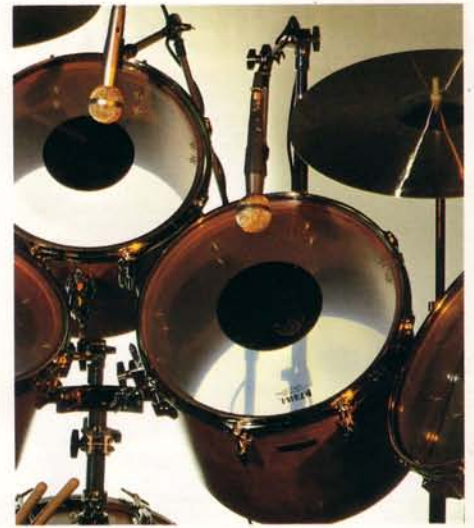

Cymbals not included.
Finish shown : Custom Mahogany



TAMA SUPERSTAR OUTFITS



SUPERSTAR 7C

OUTFIT No.9677

- 9624 14" x 24" Bass drum
- 8005 5" x 14" King-Beat Snare drum
- 9662 8" x 12" Concert tom tom
- 9663 9" x 13" Concert tom tom
- 9664 10" x 14" Concert tom tom
- 9665 12" x 15" Concert tom tom
- 9638 16" x 18" Floor tom tom
- 6920 Spartan Snare Stand
- 6922 Spartan Cymbal stands (2)
- 6925 Spartan Hi-hat stand
- 6899 Titan Double tom tom stands (2)
- 6755 King-Beat Drum pedal
- 5B Drum sticks

Cymbals not included.

Finish shown : Custom Mahogany



SUPERSTAR CONCERT TOM TOMS

- | | |
|------------------|-------------------|
| 9656 5 1/2" x 6" | 9660 6 1/2" x 10" |
| 9658 5 1/2" x 8" | 9662 8" x 12" |
| 6899 Stand | 6899 Stand |

Hi-Pitch outfit No.9668

- | | |
|----------------|----------------|
| 9663 9" x 13" | 9665 12" x 15" |
| 9664 10" x 14" | 9666 14" x 16" |
| 6899 Stand | 6899 Stand |

Low-Pitch outfit No.9669

Complete 8-pcs outfit No.9670

INDIVIDUAL DRUMS & AVAILABLE SIZES

BASS DRUMS include Spurs and Felt muffler

- | | |
|----------------|----------------|
| 9618 14" x 18" | 9620 14" x 20" |
| 9622 14" x 22" | 9624 14" x 24" |

TOM TOMS

- | | |
|----------------|----------------|
| 9612 8" x 12" | 9613 9" x 13" |
| 9614 10" x 14" | 9615 12" x 15" |

FLOOR TOM TOMS include legs

- | | |
|----------------|----------------|
| 9634 14" x 14" | 9636 16" x 16" |
| 9638 16" x 18" | |

TAMA FIBRESTAR OUTFITS



Tama Fibrestar - for the drummer who needs a louder, brighter and more power-

ful sound and bulletproof durability. Constructed of hand laid up fibreglass, Fibrestar shells are strong beyond comparison.

Tama uses only "Black Fibre" fibreglass (the strongest there is) and a special finishing process that puts a super accurate lathe-finished sound edge on the shell.

Fibrestar drums are several times stronger and considerably heavier than wood shells. This translates down to incredible durability and a loud, direct tone, rich in upper harmonics.

Tama Fibrestar drums are available in **Platina**, **Royal Pewter**, and **Midnight Blue**. You also have the option of **Tama Spartan**, **Titan** or **Mercury** hardware.

FIBRESTAR 8

OUTFIT No.9288

- 9222 14" x 22" Bass Drum
- 6682 Double tom tom holder
- 8005 5" x 14" King-Beat Snare drum
- 9212 8" x 12" Tom tom
- 9213 9" x 13" Tom tom
- 9214 10" x 14" Tom tom
- 9215 12" x 15" Tom tom
- 9236 16" x 16" Floor tom tom
- 9238 16" x 18" Floor tom tom
- 6890 Titan Snare Stand
- 6892 Titan Cymbal Stands (2)
- 6895 Titan Hi-hat Stand
- 6899 Titan Double tom tom stand
- 6755 King-Beat Drum pedal
- 5B Drum Sticks

Cymbals not included.

Finish shown: **Midnight Blue**



TAMA FIBRESTAR OUTFITS



FIBRESTAR 6

OUTFIT No.9286

- 9222 14" x 22" Bass Drum
- 6682-3T Triple tom tom holder
- 8005 5" x 14" King-Beat Snare drum
- 9212 8" x 12" Tom tom
- 9213 9" x 13" Tom tom
- 9214 10" x 14" Tom tom
- 9236 16" x 16" Floor tom tom

- 6890 Titan Snare stand
- 6892 Titan Cymbal stands (2)
- 6895 Titan Hi-hat stand
- 6755 King-Beat Drum pedal
- 5B Drum sticks

Cymbals not included.

Finish shown : Midnight Blue



FIBRESTAR CONCERT TOM TOMS

- | | |
|------------------|-------------------|
| 9256 5 1/2" x 6" | 9260 6 1/2" x 10" |
| 9258 5 1/2" x 8" | 9262 8" x 12" |
| 6899 Stand | 6899 Stand |

Hi-Pitch outfit No.9268

- | | |
|----------------|----------------|
| 9263 9" x 13" | 9265 12" x 15" |
| 9264 10" x 14" | 9266 14" x 16" |
| 6899 Stand | 6899 Stand |

Low-Pitch outfit No.9269

Complete 8-pcs outfit No.9270

INDIVIDUAL DRUMS & AVAILABLE SIZES

BASS DRUMS include Spurs and Felt Muffler

- | | |
|----------------|----------------|
| 9222 14" x 22" | 9224 14" x 24" |
|----------------|----------------|

TOM TOMS

- | | |
|----------------|----------------|
| 9212 8" x 12" | 9213 9" x 13" |
| 9214 10" x 14" | 9215 12" x 15" |

FLOOR TOM TOMS include legs

- | | |
|----------------|----------------|
| 9234 14" x 14" | 9236 16" x 16" |
| 9238 16" x 18" | |



FIBRESTAR 5

OUTFIT No.9285

- 9222 14" x 22" Bass Drum
- 6682 Double tom tom holder
- 8005 5" x 14" King-Beat Snare drum
- 9212 8" x 12" Tom tom
- 9213 9" x 13" Tom tom
- 9236 16" x 16" Floor tom tom

- 6890 Titan Snare stand
- 6892 Titan Cymbal stands (2)
- 6895 Titan Hi-hat stand
- 6755 King-Beat Drum pedal
- 5B Drum sticks

FIBRESTAR 4

OUTFIT No.9284

Same as 9285 outfit, but less 12" tom tom, and with 6681 single tom tom holder.

Cymbals not included.

TAMA IMPERIALSTAR OUTFITS



Tama Imperialstar - the heavyweight standard for wood drums. Constructed of nine plies of select mahogany, Imperialstar drums offer a great consistency of tone and drum-to-drum balance.

In the few short years they have been available, they have proven themselves on the road and in the studio with some of America's hardest playing and hardest touring bands.

The Heat Compression shell is additionally strengthened by two reinforcing rims inside the shell. The inside surface of Imperialstar drums is finished with "Zola-Coat", a tough, durable finish that provides an excellent moisture barrier for consistency of sound year in and year out.

Imperialstar kits are available in a wide range of finishes including **Platina**, **Metallic White**, **Midnight Blue**, **Hairline Chrome**, **Jet Black**, **Metallic Blue** and **Royal Pewter**. Imperialstar sets are also available with your choice of **Tama Titan**, **Spartan** or **Mercury** hardware.

IMPERIALSTAR SATURN 12+1 OUTFIT No.8993

- 8522 14" x 22" Bass Drums (2)
- 6682 Double tom tom holders (2)
- 8005 5" x 14" King-Beat Snare drum
- 8556 5 1/2" x 6" Concert tom tom
- 8558 5 1/2" x 8" Concert tom tom
- 8560 6 1/2" x 10" Concert tom tom
- 8562 8" x 12" Concert tom tom
- 8563 9" x 13" Concert tom tom
- 8564 10" x 14" Concert tom tom
- 8565 12" x 15" Concert tom tom
- 8566 14" x 16" Concert tom tom
- 8536 16" x 16" Floor tom tom
- 8538 16" x 18" Floor tom tom
- 6890 Titan Snare stand
- 6892 Titan Cymbal stands (3)
- 6895 Titan Hi-hat stand
- 6899 Titan Double tom tom stands (2)
- 6740 Hi-Beat Drum pedals (2)
- 5B Drum sticks

Cymbals not included.

Finish shown: **Platina**



TAMA IMPERIALSTAR OUTFITS



IMPERIALSTAR SATURN 9

OUTFIT No.8989

- 8522 14" x 22" Bass drum
- 6682 Double tom tom holder
- 8005 5" x 14" **King-Beat** Snare drum
- 8560 6-1/2" x 10" Concert tom tom
- 8562 8" x 12" Concert tom tom
- 8563 9" x 13" Concert tom tom
- 8564 10" x 14" Concert tom tom
- 8565 12" x 15" Concert tom tom
- 8566 14" x 16" Concert tom tom
- 8538 16" x 18" Floor tom tom

- 6890 **Titan** Snare stand
- 6892 **Titan** Cymbal stands (3)
- 6895 **Titan** Hi-hat stand
- 6899 **Titan** Double tom tom stands (2)
- 6740 **Hi-Beat** Drum pedal
- 5B Drum sticks

Cymbals not included.
Finish shown : Platina



IMPERIALSTAR SATURN 7

OUTFIT No.8987

- 8524 14" x 24" Bass Drum
- 6682 Double tom tom holder
- 8005 5" x 14" **King-Beat** Snare drum
- 8563 9" x 13" Concert tom tom
- 8564 10" x 14" Concert tom tom
- 8565 12" x 15" Concert tom tom
- 8566 14" x 16" Concert tom tom
- 8538 16" x 18" Floor tom tom

- 6890 **Titan** Snare stand
- 6892 **Titan** Cymbal stands (3)
- 6895 **Titan** Hi-hat stand
- 6899 **Titan** Double tom tom stand
- 6740 **Hi-Beat** Drum pedal
- 5B Drum sticks

Cymbals not included.
Finish shown : Platina

TAMA IMPERIALSTAR OUTFITS

MARS 4 OUTFIT No.8904



CHOICE OF YOUR SET

Shown on these pages are the most popular configurations, beginning with basic sets and progressing to the more complex outfits. These standard kits are designed to offer you the sets that most drummers prefer. However, if you wish to customize a set of your own, you may order the individual drums and hardware.

NOTE:

All these set consist of:
TITAN STANDS, HI-BEAT DRUM PEDAL and KING-BEAT SNARE DRUM.

Cymbals not included.
 Finish shown : Metallic White

MARS 5A OUTFIT No.8935



MARS 5 OUTFIT No.8905



MARS 5LX OUTFIT No.8915



MARS 6S OUTFIT No.8946



MARS 6/3T OUTFIT No.8916



TAMA IMPERIALSTAR OUTFITS

MARS 6 OUTFIT No.8906



MARS 8 OUTFIT No.8908



MARS 9 OUTFIT No.8909



Cymbals not included.
Finish shown : Metallic Blue

TAMA IMPERIALSTAR OUTFITS

MERCURY 4 OUTFIT No.8704



NOTE:

All these sets consist of:
**MERCURY STANDS, HI-BEAT DRUM
 PEDAL and 8045 SNARE DRUM.**

Cymbals not included.
 Finish shown: Royal Pewter

MERCURY 5 OUTFIT No.8705



MERCURY 6 OUTFIT No.8706



MERCURY 5LX OUTFIT No.8715



TAMA IMPERIALSTAR OUTFITS



8556 5 1/2" x 6"	8560 6 1/2" x 10"	8563 9" x 13"	8565 12" x 15"
8558 5 1/2" x 8"	8562 8" x 12"	8564 10" x 14"	8566 14" x 16"
6899 Stand	6899 Stand	6899 Stand	6899 Stand
Hi-Pitch outfit No.8568		Low-Pitch outfit No.8569	

Complete 8-pcs outfit No.8570



BASS DRUMS include Spurs and Felt Muffler.	8518 14" x 18"	8520 14" x 20"	8522 14" x 22"
	8524 14" x 24"	8526 14" x 26"	
TOM TOMS	8512 8" x 12"	8513 9" x 13"	8514 10" x 14"
	8515 12" x 15"		
FLOOR TOM TOMS include legs.	8534 14" x 14"	8536 16" x 16"	8538 16" x 18"

IMPERIALSTAR CONCERT TOM TOMS

Tama concert tom toms are furnished with Tama C. S. heads as standard equipment.

The rugged dependability and excellent volume and tone of Tama concert tom toms are fast making them a favorite among drummers. This year's Tama concert tom toms feature the same mounting bracket as Tama double headed tom toms for ease of interchangeability. Many drummers are combining concert and double headed tom toms in the same set, so Tama concert tom toms now feature the same brackets and stands as Tama double headed tom toms.

The addition of a new extra low concert tom tom stand lets larger concert tom toms double as floor tom toms.

Feature for feature, Tama concert tom toms offer you more performance and more variety of set-up than any other concert tom toms.

Finish shown: Jet Black

INDIVIDUAL DRUMS & AVAILABLE SIZES

In addition to being available in sets, all Tama drums are available separately, allowing you to add to your existing kit or to customize a set of your own from the ground up.

Bass Drums-Tama Bass drums are furnished individually with both heads and spurs mounted. There is no tom tom holder supplied on individual bass drums and must be ordered separately.

Tom Toms-All tom toms are furnished complete with **Key-Lock** mounting brackets. These brackets are compatible with either Tama tom tom holders or tom tom stands.

All Tama Drums (with the exception of concert tom toms) are furnished with **Tama Ambassador** heads as standard equipment. **Tama C. S.** heads are available as options at extra cost.

All Tama concert tom toms are furnished with **Tama C. S.** heads as standard equipment.

Finish shown: Hairline Chrome

NEW PERCUSSION IDEAS FROM TAMA

NEW TAMA GONG BASS DRUMS

The new Tama Gong Bass Drum was developed in cooperation with Billy Cobham to extend the melodic range of his Tama set. This unique drum has a very deep, but very clear and resonant tone. Single headed in construction, the Gong Bass uses a head 2 inches larger in diameter than the shell. This allows for maximum freedom of vibration.

The Gong principal would not be possible without the development of a new stand, so the new Tama Rollaway Stand was born. This stand will locate the Gong Bass in any desired position, while taking up a minimum of floor space. The casters are lockable, making the Rollaway Stand stable and immovable.

Available in either Natural Maple or Custom Mahogany lacquer finishes.

9650 Gong Bass Drum...20" shell & 22" head

9652 Gong Bass Drum...22" shell & 24" head

Tama Gong Bass Drums are sold complete with Tama rollaway stand.



TAMA GONG TOMS

Tama has also applied the Gong Bass principle to smaller diameter toms, offering yet another advancement in sound.

Gong Toms feature heads that are one inch larger in diameter than the drum shell. This design gives the heads maximum freedom of vibration for excellent response, extra volume and brilliance of tone.

Gong Toms come equipped with Tama Key-Lock brackets and are compatible with all Tama tom tom stands.

Model No.	Shell Dia.	Head Dia.	Shell Depth
9692	12"	13"	8"
9693	13"	14"	9"
9694	14"	15"	10"
9695	15"	16"	12"
Gong Floor Tom			
9696	16"	18"	16"
9698	18"	20"	16"

TAMA ROLLAWAY STANDS

With more drummers demanding a more versatile, stable and professional set up, Tama now introduces the ultimate in drum stands-the Tama Rollaway Stand. This stand features a heavy, high pressure die-cast base with lockable heavy casters.

This versatile stand can hold four tom toms, or with optional Tama Multi-Clamps, can support up to eight tom toms or any combination of toms, cymbals and mikes. This represents a true advancement in drum set up, particularly for the touring professional. It can save valuable time, especially during between act change-overs, and you can be sure that your drums and mikes are set up exactly the way they were at sound check.

The Rollaway Stand is fully adjustable, both in height and width, to accommodate any size drums or drum/cymbal combination. It comes complete with two Tama double tom holders, but can accept the upper portion of any **Tama Spartan** or **Titan** stand. Combined with the **Tama Multi-Clamp system**, it's the most versatile drum stand ever offered.

6901 Rollaway Stand, complete with 2 double tom tom holders.

NEW PERCUSSION IDEAS FROM TAMA

TAMA OCTOBAN 8A

OUTFIT No. 7800

Tama Octoban Features

Eight Tune Lengths -With equal head tension, Octobans produce a perfect diatonic octave. They can also be tuned in a wide variety of scales and pitches for almost limitless melodic/percussive effects.

Fibre Construction -There are no seams to split or open up. The fibre shell are the strongest of their type and are full 4 mm thick in **Mat Black** finish.

Lathe-Turned Sound Edge -For a precision head fit and maximum volume and attack.



TAMA OCTOBANS OPENING A NEW WORLD OF MELODIC PERCUSSION

Today's drummer has to know more than just hitting it on the 2 and the 4. The world of drums and percussion has broadened its musical view in the last decade. And this expanding horizon has brought with it many new percussion products, and most importantly a new drum company, **Tama** - the strongest new name in drums.

And now from Tama-one of the most innovative and exciting drum products of the 70's-Octobans. These melodic drums are designed with a distinctive tonal color and now give the drummer the opportunity to put melody to work.

Already, drummers such as the incredible **Billy Cobham**, and **Gary Mallaber** of the **Steve Miller** band are using and praising Octobans. Billy is using his Octobans to add melodic continuity and punctuation to his solos and Gary uses Octobans to add a melodic/percussive texture to several of Steve Miller's finely crafted tunes. And the experimentation with Octobans is sure to go on for a long long time.

But, why wait? Become part of the vanguard. Get your Octobans Today!

OTHER ACCESSORIES



DRUM & CYMBAL COVERS

Tama drum covers and cymbal bags are available in sizes fit most drums and to cymbals. These durable, washable vinyl bags are black with a white Tama logo, and feature extra stitched carrying handles.

A stick and accessory bag is also available which can be mounted on the floor tom tom for easy accessibility.

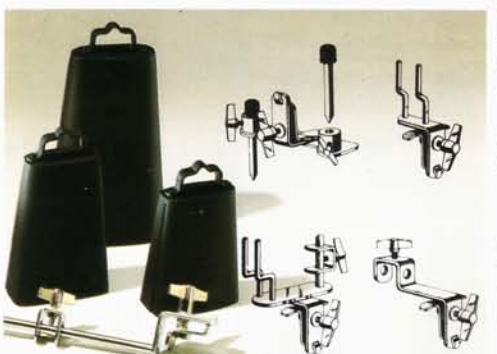

BASS DRUM ANCHOR

A bass drum rim clamp anchor with either rubber tips or stage spikes. Provides additional protection against bass drum creep.

6348 Bass drum anchor

COW-BELLS

6304...4" Cow-bell

6306...6" Cow-bell

6305...5" Cow-bell

6309...8" Cow-bell

BASS DRUMS

7188...14" x 18"

7190...14" x 20"

7192...14" x 22"

7194...14" x 24"

7196...14" x 26"

TOM TOMS

7160...6 1/2" x 10"

7162...8" x 12"

7163...9" x 13"

7164...10" x 14"

7165...12" x 15"

7166...14" x 16"

FLOOR TOM TOMS

7174...14" x 14"

7176...16" x 16"

7178...16" x 18"

SNARE DRUMS

7155...5" x 14"

7156...6 1/2" x 14"

CYMBAL BAGS

7180...20"

7182...22"

7184...24"

STICK BAG

7170 ...Stick bag

TAMA SHELL SUPPORTER

With many drummers playing single headed bass drums, the Tama shell support can perform several functions. It will prevent ovaling of the shell due to tom tom weight, prevent damage in transit, and keep a pillow or other muffler in place.

6635 Shell supporter

TAMA 2-WAY SPURS & LEGS

Tama bass drum spurs and tom tom legs feature the Tama 2-Way convertible tip.

The rubber tip easily retracts to expose a sharp and gripping anchor tip. Tama bass drum spurs are also slanted forward 15° to virtually eliminate bass drum creep.

6580 Bass drum spurs, set

6575 Floor tom tom legs, set of 3

HI-HAT HOLDER

This Tama specialty allows double bass drum users to bring their hi-hat right in close to their bass drum pedal. This extra heavy duty clamp will hold your hi-hat at just about any angle, often necessary to clear tom toms.

6323 Hi-hat holder

CYMBAL HOLDER

6630 Shell mount cymbal holder

COW-BELL HOLDER, WOOD BLOCK HOLDER & COMBINATION HOLDER

These Tama accessories allow you to add cow-bells, wood-blocks and other percussion paraphernalia to your set.

The convenient rim clamp attaches to the bass drum rim.

6310 ...Cow-bell holder w/clamp

6311 ..."U" clamp only

6314 ...Wood-block

6315 ...Wood-block holder

6325 ...Combination set, includes 4" cow-bell, wood-block and holder

6320 ...Combination holder

NEW PERCUSSION IDEAS FROM TAMA

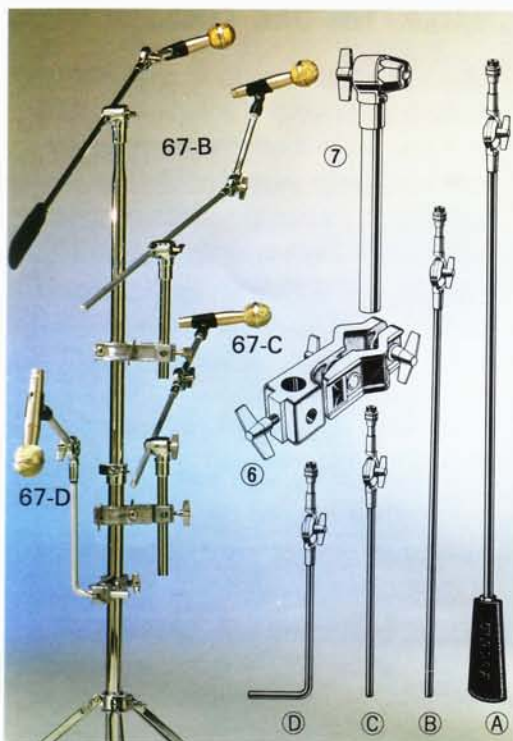

THE TAMA MULTI-CLAMP HARDWARE SYSTEM

Today's drummer is using more and more accessories than his forerunners and more and more drummers are miking their drum sets for a more balanced group sound. The Tama Multi-Clamp Hardware System grew from the need to more adequately mount accessories and microphones. You can now not only custom design your Tama set, but your Tama hardware as well. The Multi-Clamp System is based on the versatile multi-clamp with many, many optional parts for just about any application.

Extra tom toms can be added, extra cymbals placed anywhere around the kit, and complete set of mikes can be mounted to your existing hardware without purchasing new stands. The result is an efficient, good looking and professional set-up wherever you play.



SUGGESTIONS ON MIKING YOUR DRUM SET

The number and location of microphones will depend on your application and, of course, the number of drums. In a live situation, where you are miking drums through a sound reinforcement system, a five piece set can be adequately miked with 3 to 6 mikes. The bass drum, snare, and floor tom tom should have their own mikes and the mounted tom toms may share a mike placed near the top head and between both drums. You'll probably find that the leakage from these mikes will pick up the cymbals and the hi-hat quite adequately. In a larger concert situation, you may find it necessary to mike the hi-hat individually and use one or two overheads for cymbals.

When using concert tom toms, many soundmen prefer to use one mike per drum and place the mike up inside the shell. This technique is most effective, but if you have eight concert tom toms, you'll need eight mikes.

For recording, just about any percussive surface is miked individually for the maximum control. Recording engineers often

mike the snare from both the top and the bottom in order to be able to mix the snare very precisely. Much of the other mike placement is trial and error until you get a sound you like.

If your budget or mixer inputs limit you to two or three mikes for your entire set, a bass drum mike and an overhead pointing down at the snare drum will get you by with surprisingly good results. Anyway you mike drums, however, the Tama Multi-Clamp system can do the job.

MIKE HOLDERS

67-B w/24" straight rod

67-C w/12" straight rod

60-D w/"L" shaped rod

⑥ Multi-clamp, ⑦ Ratchet arm and holders are available separately, allowing you to add to your existing kit. **6000 Titan Mike stand.** Specialty designed for drum miking.

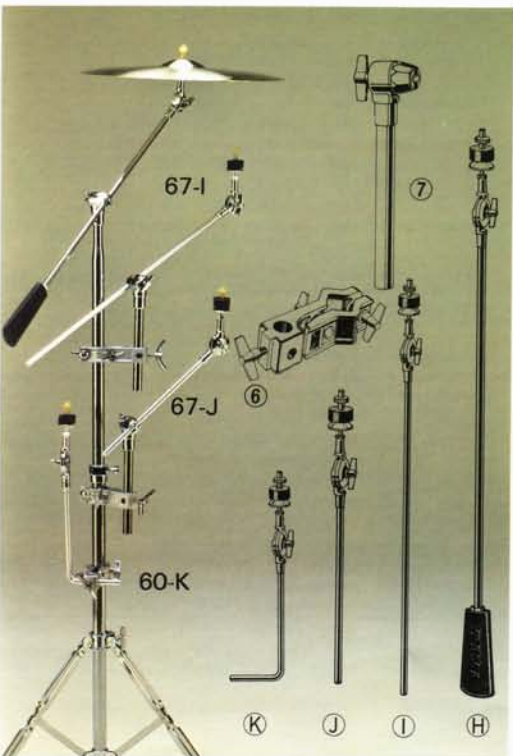

CYMBAL HOLDERS

67-H w/counter weight

67-I w/24" straight rod

67-J w/12" straight rod

60-K w/"L" shaped rod

DRUM STICKS & PARTS

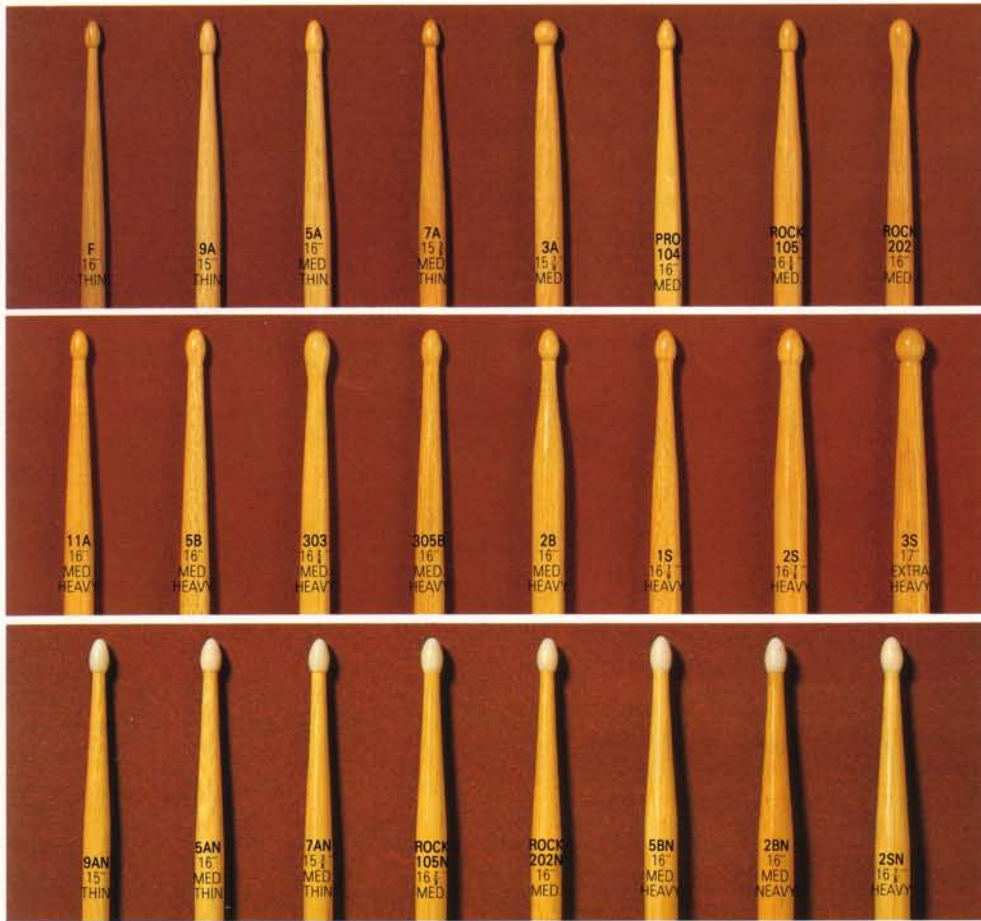

TAMA - THE OAK STICKS

Unlike many drumsticks, Tama sticks are made from cured and seasoned oak. But why oak? Oak is a very hard wood with excellent grain consistency from piece to piece. When properly cured, oak is very stable and will resist warping to a great degree. When applied to drumsticks, these properties are most important. First of all, a hard stick will be durable. Oak sticks resist chipping and cracking better than any others. Also, a hard stick will be very lively, with excellent rebound from both drums and cymbals. What does grain consistency mean? It means that every stick of a particular size and demension will weight almost exactly the same as any other of the same size stick, and will balance and respond exactly the same. Sticks of other materials often vary in weight and balance, so finding a matched pair can be a real hassle.



TAMA PARTS KIT

Tama offers two parts kits - one for drums and for hardware and stands. Both kits include all you'll ever need, on the road or in the shop. Both kits include a custom cabinet for parts and tools.



DRUM PARTS KIT No.DK-6703

- 2 pcs. DK-1 "T" rods
usage: bass drums
- 10 pcs. DK-2 washers
usage: all rods
- 2 pcs. DK-3 Hooks
usage: bass drum rods
- 5 pcs. DK-4 Rods
usage: floor tom toms
- 10 pcs. DK-5 Rods
usage: snares & tom toms
- 2 pcs. DK-6 Lugs
usage: tom toms
- 1 pc. DK-7 Lug
usage: snare drums
- 1 pc. DK-8 Lug
usage: bass drums
- 10 pcs. DK-9 Lug nuts
usage: all lugs
- 10 pcs. DK-10 Nylon lug nut stoppers
usage: all lugs
- 10 pcs. DK-11 Mounting screws
usage: all lugs
- 2 pcs. DK-12 Rubber tips
usage: spurs & legs
- 2 pcs. DK-13 Thumb screws
usage: tom holders & spurs
- 5 pcs. DK-14 Plastic straps
usage: snappy snares
- 1 pc. DK-15 Eye bolt assembly
usage: mounting brackets
- 2 pcs. DK-16 Wing nuts
usage: tom tom holder & brackets.
- 1 pc. DK-17 Eye bolt assembly
usage: tom tom holders
- 1 pc. DK-18 Hex wrench w/5 hex nuts
usage: tom tom holders & brackets (extra use)
- 2 pcs. DK-19 Snare butt plates w screws
usage: snare butts
- 2 pcs. DK-20 Tone control dampers
usage: all drums

STAND PARTS KIT No.SK-6701

- 4 pcs. SK-1 Plastic bushings w/pin
usage: stands (big 28.6)
- 2 pcs. SK-2 Plastic bushings w/pin
usage: stands (medium 22.2)
- 2 pcs. SK-3 Plastic bushings w/pin
usage: stands (small 19.1)
- 3 pcs. SK-4 Wing screws
usage: stands
- 2 pcs. SK-5 Thumb screws
usage: stands
- 2 pcs. SK-6 Rubber tip assemblies
usage: stands (6920-6925)
- 2 pcs. SK-7 Rubber tips
usage: stands (6890-6895)
- 2 pcs. SK-8 Rubber tips
usage: stands (6870-6875)
- 2 pcs. SK-9 Felt washers
usage: hi-hat bottom seat
- 2 pcs. SK-10 Metal washers
usage: hi-hat bottom seat
- 2 pcs. SK-11 Bolt & nut assemblies
usage: hi-hat bottom seat
- 1 pc. SK-12 Hi-hat strap assembly
usage: hi-hat stands
- 3 pcs. SK-13 Non-loose hex nuts
usage: hi-hat stands
- 1 pc. SK-14 Hi-hat clutch, complete
usage: hi-hat stands
- 2 pcs. SK-15 Non-loose plastic nuts
usage: hi-hat stands
- 1 pc. SK-16 Snare bolt & nut assembly
usage: snare stands
- 2 pcs. SK-17 Wing nuts
usage: stands & brackets
- 1 pc. SK-18 Cymbal tiler assembly
usage: cymbal stands
- 3 pcs. SK-19 Nylon treaded tube
usage: cymbal stands
- 1 pc. SK-20 Bolt & nut assembly
usage: cymbal stands

TAMA DRUM WARRANTY

Tama drums are guaranteed against defects in materials and workmanship for a period of five years from the date of original retail purchase.

Tama drum shells are warranted against going out of round or splitting. Tama hoops are warranted against breakage under normal use.

This warranty is subject to the limitations contained herein, and is extended to the original retail purchaser only, and is not transferable.

This warranty does not cover any instruments that have been altered or modified or which have been damaged through misuse, negligence accident or improper operation. Normal wear and tear, sound,

heads, plating, drumsticks, brushes, beaters, spring, straps and damages in shipping and transport are not covered. This warranty is not extended to instruments purchased from an unauthorized dealer.

Tama makes no other express warranty of any kind whatsoever. All implied warranties, including warranties of merchantability and fitness for a particular purpose, exceeding the duration of this warranty are hereby disclaimed and excluded from this warranty. Tama disclaims liability for any incidental and consequential damages arising out of the use of this product. All warranty claims will be handled by an Authorized Tama Service Center. The defective instrument must be returned to

the Tama Service Center freight and insurance prepaid only after proper return authorization has been approved. We suggest that this return be handled by an authorized Tama dealer.

Upon inspection and evaluation, Tama alone will determine the extent of liability and will notify the claimant as to the decision. Repaired instruments will be returned to the claimant freight collect.

SUPERSTAR

AVAILABLE DRUM COLORS



NATURAL MAPLE



CUSTOM MAHOGANY



PLATINA

FIBRESTAR

AVAILABLE DRUM COLORS



PLATINA



ROYAL PEWTER



MIDNIGHT BLUE

IMPERIALSTAR

AVAILABLE DRUM COLORS



JET BLACK



METALIC BLUE



ROYAL PEWTER



MIDNIGHT BLUE



METALIC WHITE



PLATINA



HAIRLINE CHROME

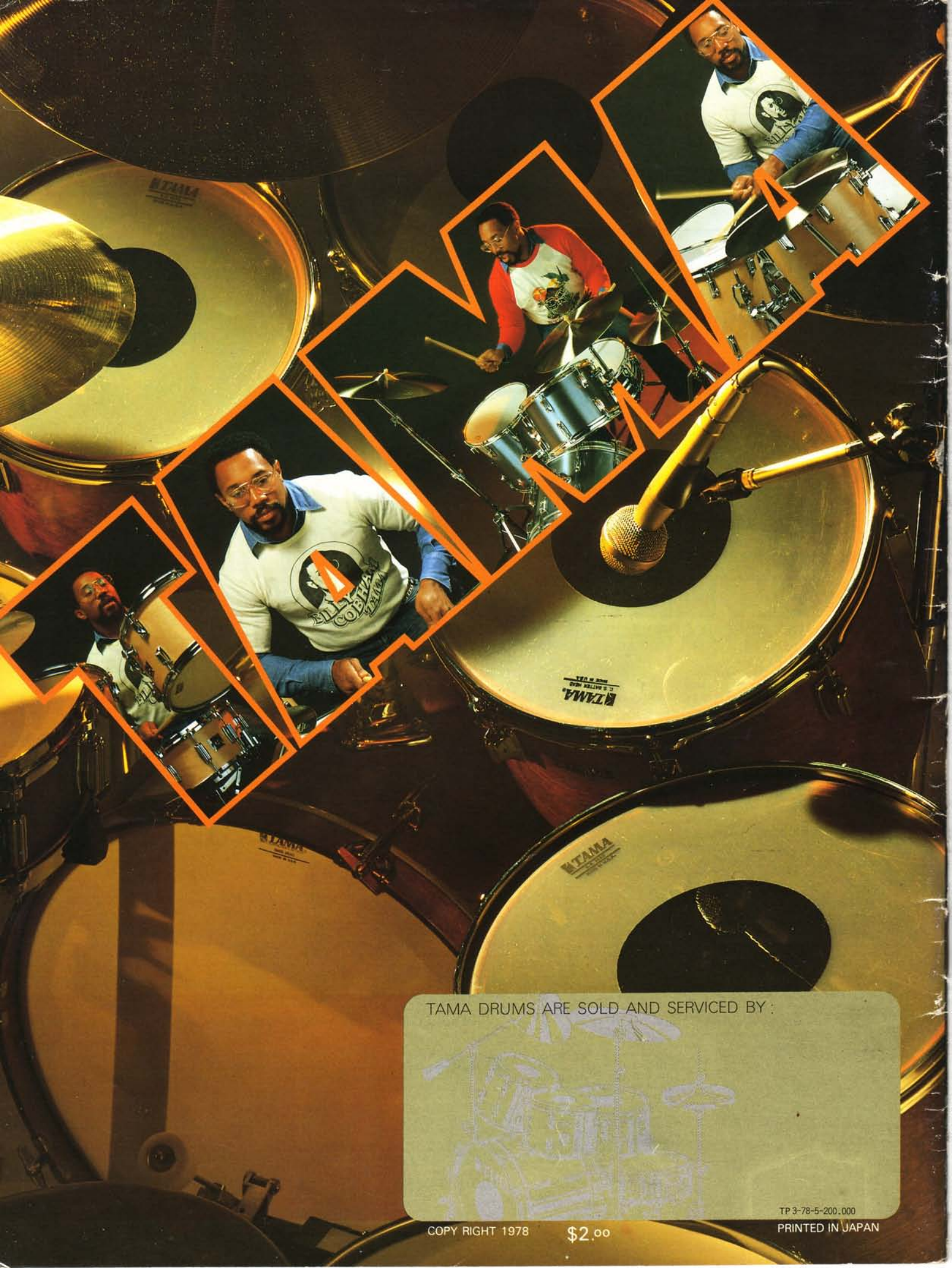

TAMA DRUMS ARE SOLD AND SERVICED BY :

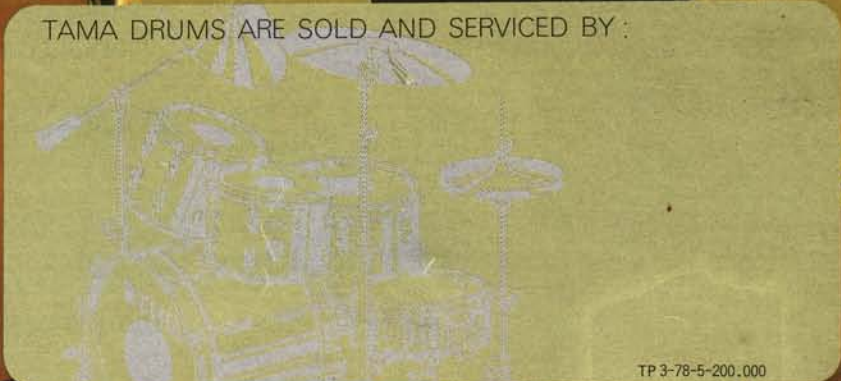

COPY RIGHT 1978

\$2.00

TP 3-78-5-200.000

PRINTED IN JAPAN