

# Camco

 **CHICAGO DRUM CENTER**  
159 N. DEARBORN ST.  
4TH FLOOR  
CHICAGO, ILL. 60601  
PHONE ST 2-0855



# Camco "THE ARISTOCRAT" OF THE DRUM WORLD

DRUMS THAT ARE CRAFTED TO THE QUALITY OF FINE MUSICAL INSTRUMENTS



JOHN ROCHON  
President



CLAIRE MAYER  
Secretary



ALFRED KNABLE  
Shop Supt.



EDWARD BECK  
Drum Dept.



CHUCK MOLINARI  
Advisor

## INDEX

|                                    |                                    |                                    |
|------------------------------------|------------------------------------|------------------------------------|
| Bass Drums ..... 11                | Drum Eye ..... 27                  | Slings, Bell Lyra ..... 31         |
| Bass Drum Anchors ..... 19         | Drum Key ..... 27                  | Slings, Drum ..... 27              |
| Bass Drum Mufflers ..... 30        | Drum Major Whistles ..... 27       | Snare Drums ..... 7, 8, 9          |
| Bass Drum Racks ..... 27           | Drum Outfits ..... 3, 4, 5, 6      | Snares ..... 30                    |
| Bell Lyras ..... 31                | Drum Stands ..... 16               | Snare Drum Muffler ..... 30        |
| Bell Lyra Stands ..... 31          | Gongs and Stands ..... 24          | Snare Strainers ..... 33           |
| Cases, Fibre ..... 32              | Greeko Cymbals ..... 24            | Song Whistles ..... 29             |
| Castanets ..... 29                 | Guiro ..... 28                     | Spurs ..... 19                     |
| Ching Ring ..... 25                | Heads, Plastic & Calfskin ..... 26 | Square Head Rods ..... 34          |
| Claves ..... 28                    | Hi-Hat Stands ..... 15             | Sticks, Base Drum ..... 22, 23, 27 |
| Covers ..... 32                    | Imitations ..... 29                | Sticks, Snare Drum ..... 20, 23    |
| Cow Bells ..... 28                 | Instruction Books ..... 35         | Sticks, Tenor ..... 23             |
| Cow Bell Holders ..... 17-30       | Jingle Muffler ..... 29            | Sticks, Tympani ..... 22           |
| Cymbals ..... 24                   | Key Holders ..... 27               | Swivel Holders ..... 18            |
| Finger Cymbals ..... 24            | Kits, Drum ..... 9                 | Tambourines ..... 29               |
| Cymbal Clutches ..... 15           | Latin Accessories ..... 28         | Thrones ..... 16                   |
| Cymbal Floor Stands ..... 16       | Leg Rests ..... 27                 | Tom-Toms ..... 10                  |
| Cymbal Holders, Band ..... 25      | Mallets ..... 22, 23, 31           | Tom-Tom Holders ..... 18           |
| Cymbal Holders, Bass Drum ..... 17 | Maracas ..... 28                   | Tom-Tom Legs ..... 10              |
| Cymbal Holders, Brush ..... 17     | Parade Drums ..... 9, 12, 13       | Tone Controls ..... 30             |
| Cymbal Holders, Hoop ..... 17      | Pedals ..... 14                    | Triangles ..... 30                 |
| Cymbal Holders, Shell ..... 17     | Pedal Beaters ..... 19             | Triangle Holders ..... 30          |
| Cymbal Holders, Wood ..... 25      | Practice Pads ..... 21, 26         | Whistles ..... 27, 29              |
| Cymbal Pads ..... 25               | Practice Pad Stands ..... 21       | Wire Brushes ..... 21              |
| Cymbal Straps ..... 25             | Practice Pad Sets ..... 26         | Wood Blocks ..... 28               |
| Cymbal Pouches ..... 32            | Replacement Parts ..... 33, 34     | Wood Block Holders ..... 17, 30    |
| Cymbal Sizzlers ..... 25           | Slap Sticks ..... 29               | Wood Rattle ..... 29               |
| Cymbal Tilters ..... 15            | Sleigh Bells ..... 29              | Wood Whistles ..... 29             |

## TERMS

### CAMCO PRODUCTS ARE SOLD THROUGH DEALERS IN OPEN TERRITORIES ONLY

All previous quotations cancelled. All prices are list, subject to change without notice and to the usual terms. F.O.B. shipping point. New accounts please submit three trade references and bank.

Substitutions permissible. Colors matched on non-cancellable, non-returnable basis. All metal parts chrome plated. Heads and Cymbals not guaranteed.

Plastic heads standard on all drums unless otherwise specified. Calf Skin Heads priced extra.

Claims for losses, damages or pilferage must be made to the Transportation Company. Our responsibility ceases upon delivery to the Transportation Company. Shipments should be opened and examined immediately for loss or damage, either VISIBLE or CONCEALED.

Check all contents and save all cartons and packing material. Call your local agent at once for an inspection. Obtain a signed inspection report from him and file claim for loss or damage.



EDDIE GRAHAM  
Clinician



SHELDON ELIAS  
Clinician

2018.256.001

|                      |      |  |          |
|----------------------|------|--|----------|
| 1                    | 450  | Aristocrat 5 x 14 Snare Drum                   | \$ 90.00 |
| 1                    | 1120 | Aristocrat 14 x 20 Bass Drum                   | 130.00   |
| 1                    | 1412 | Aristocrat 8 x 12 Tom-Tom                      | 70.00    |
| 1                    | 1414 | Aristocrat 14 x 14 Tom-Tom                     | 85.00    |
| 1 pr.                | 1480 | Arch Disappearing Spurs                        | 7.50     |
| 1                    | 15   | Single Swivel Tom-Tom Holder                   | 18.00    |
| 1 set                | 4410 | Tom-Tom Legs                                   | 9.00     |
| 1                    | 1450 | Shell Mount Cymbal Holder                      | 8.50     |
| 1                    | 5000 | Deluxe Foot Pedal                              | 24.50    |
| 1                    | 500  | Direct Pull Hi-Hat Stand-Tripod Legs           | 33.50    |
| 1                    | 650  | Buck Rogers Drum Stand-Tripod Legs             | 17.50    |
| 1                    | 1103 | Cow Bell                                       | 2.10     |
| 1                    | 1070 | Cow Bell Holder                                | 3.00     |
| 1                    | 1422 | Wire Brushes, Rubber Covered Handles, Loop End | 1.75     |
| 1                    | 1430 | Felt Muffler Strip                             | 1.00     |
| 1 pr.                |      | Drum Sticks                                    | 1.40     |
|                      |      | Total Value:                                   | \$502.75 |
| Cymbals not included |      | Special Price:                                 |          |
|                      |      | Pearl Finishes                                 | \$475.00 |
|                      |      | Lacquer or Stain Finishes                      | \$428.50 |
|                      |      | Moire Finishes                                 | \$499.00 |

# Camco

"NICK CEROLI"

OUTFIT



NICK CEROLI  
Tijuana Brass



• Double Flange Counter Hoops

• 6-Ply Electronically Bonded Shells

• All Metal Parts AAA Chrome Plated

DRUMS SHOWN IN BURGUNDY SPARKLE

## Camco DRUM COMPANY

9221 SOUTH KILPATRICK AVENUE  
OAKLAWN ILL. 60453 • Area Code (312) PHONE 423-2900

# Camco

## "DOUBLE TOM-TOM" OUTFIT

|       |      |  |          |
|-------|------|--|----------|
| 1     | 450  | Aristocrat 5 x 14 Snare Drum                   | \$ 90.00 |
| 1     | 1122 | Aristocrat 14 x 22 Bass Drum                   | 135.00   |
| 2     | 1412 | Aristocrat 8 x 12 Tom-Toms                     | 140.00   |
| 1     | 1416 | Aristocrat 16 x 16 Tom-Tom                     | 90.00    |
| 1 pr. | 1480 | Arch Disappearing Spurs                        | 7.50     |
| 1     | 5000 | Deluxe Foot Pedal                              | 24.50    |
| 1     | 650  | Buck Rogers Drum Stand-Tripod Legs             | 17.50    |
| 1     | 500  | Direct Pull Hi-Hat Stand-Tripod Legs           | 33.50    |
| 1     | 18   | Double Swivel Tom-Tom Holder                   | 25.00    |
| 2     | 700  | Cymbal Stands                                  | 23.00    |
| 1 set | 4410 | Tom Tom Legs                                   | 9.00     |
| 1 pr. | 1070 | Wire Brushes, Rubber Covered Handles, Loop End | 1.75     |
| 1     | 1430 | Felt Muffler Strip                             | 1.00     |
| 1 pr. |      | Drum Sticks                                    | 1.40     |
|       |      | Total Value:                                   | \$599.15 |
|       |      | <b>Special Price:</b>                          |          |
|       |      | Pearl Finishes                                 | \$570.00 |
|       |      | Lacquer or Stain Finishes                      | \$512.00 |
|       |      | Moire Finishes                                 | \$599.00 |

Cymbals not included

with "ARISTOCRAT" Drums

- Double Flange Counter Hoops

- 6-Ply Electronically Bonded Shells
- All Metal Parts AAA Chrome Plated

Here is the "Big Apple" of all drum outfits . . . designed for the drummer who is seeking the complete range of sounds—with true drum character in every beat—and with a full measure of modern styling and mechanical perfection. This set is for both large and small bands. It is right for the classics or for jazz. There is nothing finer to be had and nothing that will give greater playing satisfaction and eye appeal than the advanced Double Tom-Tom Outfit.

DRUMS SHOWN IN BLUE MOIRE



# Camco

## "BIG BAND" OUTFIT

- Double Flange Counter Hoops
- 6-Ply Electronically Bonded Shells
- All Metal Parts AAA Chrome Plated

|       |      |  |          |
|-------|------|--|----------|
| 1     | 450  | Aristocrat 5 14 Snare Drum                     | \$ 90.00 |
| 2     | 1120 | Aristocrat 14 x 20 Bass Drums                  | 260.00   |
| 2     | 1412 | Aristocrat 8 x 12 Tom-Toms                     | 140.00   |
| 1     | 1414 | Aristocrat 14 x 14 Tom-Tom                     | 85.00    |
| 2 pr. | 1480 | Arch Disappearing Spurs                        | 15.00    |
| 1     | 19   | Double Swivel Tom-Tom Holder-on a stand        | 30.00    |
| 1 set | 4410 | Tom-Tom Legs                                   | 9.00     |
| 2     | 5000 | Deluxe Foot Pedals                             | 49.00    |
| 1     | 900  | Direct Pull Hi-Hat Stand-Flush Legs            | 33.50    |
| 2     | 700  | Cymbal Stands                                  | 23.00    |
| 1     | 850  | Buck Rogers Drum Stand-Flush Legs              | 17.50    |
| 1 pr. | 1070 | Wire Brushes, Rubber Covered Handles, Loop End | 1.75     |
| 2     | 1430 | Felt Muffler Strips                            | 2.00     |
| 1 pr. |      | Drum Sticks                                    | 1.40     |
|       |      | Total Value:                                   | \$757.15 |
|       |      | <b>Special Price:</b>                          |          |
|       |      | Pearl Finishes                                 | \$720.00 |
|       |      | Lacquer or Stain Finishes                      | \$640.00 |
|       |      | Moire Finishes                                 | \$762.00 |

Cymbals not included

DRUMS SHOWN IN 3-D MOIRE



EBONY STAIN



CLEAR MAPLE



MOSS GREEN STAIN



WALNUT STAIN



DRUMS SHOWN IN WALNUT STAIN

# Camco

## TUXEDO OUTFIT

|       |       |  |          |
|-------|-------|--|----------|
| 1     | 701   | Tuxedo 5 x 14 Snare Drum .....                       | \$ 79.50 |
| 1     | 2330  | Tuxedo 14 x 20 Bass Drum.....                        | 120.00   |
| 1     | 3012  | Tuxedo 8 x 12 Tom-Tom .....                          | 60.00    |
| 1 pr. | 1480  | Arch Disappearing Spurs .....                        | 7.50     |
| 1     | 1450  | Shell Mount Cymbal Holder .....                      | 8.50     |
| 1     | 1435C | Chrome Console Tom-Tom Holder .....                  | 13.50    |
| 1     | 600   | Drum Stand - Flush Base .....                        | 12.80    |
| 1     | 800   | Hi-Hat Stand - Flush Base .....                      | 20.00    |
| 1     | 5000  | Deluxe Foot Pedal .....                              | 24.50    |
| 1 pr. | 1070  | Wire Brushes, Rubber Covered Handles, Loop End ..... | 1.75     |
| 1     | 1430  | Felt Muffler Strip .....                             | 1.00     |
| 1 pr. |       | Drum Sticks .....                                    | 1.40     |
|       |       | Total Value: .....                                   | \$350.45 |
|       |       | <b>Special Price:</b>                                |          |
|       |       | Pearl Finishes .....                                 | \$332.90 |
|       |       | Lacquer or Stain Finishes .....                      | \$295.00 |
|       |       | Moire Finishes .....                                 | \$350.00 |

Cymbals not included

# Camco NO. 99 SUPER



## NEW PARALLEL STRAINER

\$109.00  
5x14  
in Metal or  
Choice of Pearls



### FEATURES . . .

- Snare Contacts Head Even
- Choke Free Sound
- 16 Strand Snâres
- Polished Chrome Shell
- Triple Flange Hoops
- Internal Tone Control
- Camco Key Holder
- Tone Control

99-M Super—Chrome Shell ..... \$109.00  
99-P Super—Choice of Pearl ..... \$109.00

## TUXEDO METAL DRUM

- TRIPLE FLANGE HOOPS
- 20 STRAND SNARE
- CHROME SHELL
- TONE CONTROL
- KEY HOLDER
- 8 LUGS



No. 701-M 5x14 Snare Drum ..... \$90.00

# Camco

## SWINGER OUTFIT

|       |       |  |          |
|-------|-------|--|----------|
| 1     | 450   | Aristocrat 5 x 14 Snare Drum .....                   | \$ 90.00 |
| 1     | 1120  | Aristocrat 14 x 20 Bass Drum .....                   | 130.00   |
| 1     | 1412  | Aristocrat 8 x 12 Tom-Tom .....                      | 70.00    |
| 1 pr. | 1480  | Arch Disappearing Spurs .....                        | 7.50     |
| 1     | 1435C | Chrome Console Tom-Tom Holder .....                  | 13.50    |
| 1     | 1450  | Shell Mount Cymbal Holder .....                      | 8.50     |
| 1     | 5000  | Deluxe Foot Pedal .....                              | 24.50    |
| 1     | 800   | Hi-Hat Stand - Flush Base .....                      | 20.00    |
| 1     | 600   | Drum Stand - Flush Base .....                        | 12.80    |
| 1 pr. | 1070  | Wire Brushes, Rubber Covered Handles, Loop End ..... | 1.75     |
| 1     | 1430  | Felt Muffler Strip .....                             | 1.00     |
| 1 pr. |       | Drum Sticks .....                                    | 1.40     |
|       |       | Total Value: .....                                   | \$380.95 |
|       |       | <b>Special Price:</b>                                |          |
|       |       | Pearl Finishes .....                                 | \$361.80 |
|       |       | Lacquer or Stain Finishes .....                      | \$324.80 |
|       |       | Moire Finishes .....                                 | \$379.80 |

Cymbals not included



DRUMS SHOWN IN CHAMPAGNE SPARKLE

## THE "ARISTOCRAT"

A great number of top ranking professionals declare the 5 x 14 size drum to be the best for those who do all-around work with different groups. The "ARISTOCRAT" 5 x 14 has both delicacy and volume and will withstand hard usage on the road. It is a "tailor-made" instrument of mechanical efficiency and modern styling . . . A wonderful easy-playing drum, with sounds that will please the perfectionist.

### ORCHESTRA

|                                     |         |
|-------------------------------------|---------|
| 450-P 5x14 Choice of Pearls .....   | \$90.00 |
| 450-L 5x14 Choice of Lacquers ..... | 82.00   |

### CONCERT ARISTOCRAT

|                                      |         |
|--------------------------------------|---------|
| 452-P 6½x14 Choice of Pearls .....   | \$92.00 |
| 452-L 6½x14 Choice of Lacquers ..... | 84.00   |

## THE BAND "ARISTOCRAT"

This is a real "drummer's drum," with colorful, rich and penetrating sounds that make it the very "tops" for large concert bands and orchestras. It is the correct size for producing great volume; yet it is so sensitive that it can be played down to a "whisper." Like all "ARISTOCRATS," it is very carefully made in every part—even to finishing the inside of the shell.

|                                     |         |
|-------------------------------------|---------|
| 456-P 8x15 Choice of Pearls .....   | \$95.00 |
| 456-L 8x15 Choice of Lacquers ..... | 87.00   |

Gut Snares—\$2.00 Extra

**ALL METAL PARTS  
TRIPLE CHROME  
PLATED**

## THE 'ORCHESTRA' TUXEDO

5x14 Snare Drum  
Drum Shown in Blue Moire

|                                   |         |
|-----------------------------------|---------|
| 701-P In Pearls .....             | \$79.50 |
| 701-L In Lacquers .....           | 69.50   |
| 712-P 6½x14 Choice of Pearls....  | \$81.50 |
| 712-L 6½x14 Choice of Lacquers .. | 71.50   |

Tone Control and Key Holder Included  
8 Streamline Lugs

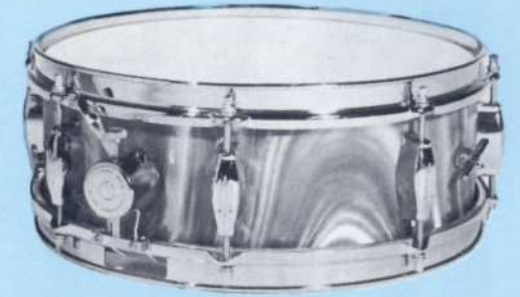

Tone Control  
Choice of Calf or Plastic Heads  
Photo Shows 5 x 14 in Sparkling Gold



Tone Control  
All Metal Parts on All Drums Are  
AAA Chrome Plated  
Photo Shows 8 x 15 in Mahogany



## STUDIO MODEL

|                                   |         |
|-----------------------------------|---------|
| 701-EL 5x14 Lacquer or Mahogany.. | \$55.00 |
| 701-EP In Pearl .....             | 65.00   |

8 Lug  
Key Holder  
Triple Flange Hoops



## No. 910-D DELUXE DRUM KIT

|                                   |                |
|-----------------------------------|----------------|
| 701-EP 5x14 Pearl Snare Drum..... | \$65.00        |
| Blue Deluxe Case.....             | 16.95          |
| 1100 Round Practice Pad.....      | 3.00           |
| 600 Flush Base Drum Stand....     | 12.80          |
| 1 Pair 2-B Drum Sticks.....       | 1.40           |
| <b>TOTAL VALUE:</b>               | <b>\$99.15</b> |
| <b>SPECIAL PRICE:</b>             | <b>94.00</b>   |



## 10" x 14" PARADE DRUM

515-L In Lacquer  
or Mahogany \$62.00  
515-P In Pearl ..... 72.00  
Sticks, Sling and Key Holder  
Included.  
Choice of Wood or Metal  
hoop. 8 Rod.



Photo Shows  
16x16 in  
3D Moire  
and 4410  
Tom-Tom Legs



Photo Shows  
9x13 in  
White Pearl



Photo Shows  
14x14 in  
Blue Moire  
and 4412  
Wide Spread Legs

## "ARISTOCRAT" TOM-TOMS

All "ARISTOCRAT" Tom-Toms have our exclusive Double Edge-Double Flange Hoops and "turret" casings with self-aligning rods. All shells are 4-Ply electronically bonded, with reinforcing hoops. Shells are finished on the inside to prevent moisture penetration. Tone Control included.

|      |       | Stain or<br>Lacquer | Pearl   |
|------|-------|---------------------|---------|
| 1412 | 8x12  | \$65.00             | \$70.00 |
| 1413 | 9x13  | 67.00               | 72.00   |
| 1414 | 14x14 | 72.00               | 85.00   |
| 1416 | 16x16 | 76.50               | 90.00   |

## CAMCO TOM-TOM LEGS

There are 12 ring notches turned into each of the chrome plated legs. Wing screws seat themselves into the notches. Legs cannot slip.

|      |                          |        |
|------|--------------------------|--------|
| 4410 | 3 Legs and Brackets..... | \$9.00 |
| 4411 | 1 Leg and Bracket.....   | 3.00   |

## "TUXEDO" TOM-TOMS

|      |       | Stain or<br>Lacquer | Pearl   |
|------|-------|---------------------|---------|
| 3012 | 8x12  | \$54.00             | \$60.00 |
| 3013 | 9x13  | 57.00               | 62.50   |
| 3014 | 14x14 | 64.00               | 75.00   |
| 3016 | 16x16 | 68.00               | 80.00   |

## CAMCO LARGE SPREAD TOM-TOM LEGS

The fine notches turned into the legs provide ample height adjustment and positively prevent slipping under heavy beating. Note that legs flare outward.

|      |                          |         |
|------|--------------------------|---------|
| 4412 | 3 Legs and Brackets..... | \$10.50 |
| 4413 | 1 Leg and Bracket.....   | 3.50    |

## Camco

## "ARISTOCRAT" BASS DRUMS

Drummers and leaders in both the school and professional fields must have the particular "sound style" that blends in with the musical character of their special organization. Jobbing drummers often have to alter the sounds for different groups. We are, therefore, building our bass drums to withstand the ally bonded shells, with reinforcing hoops. The steel double claw hooks are of thicker gauge and have a wider bearing surface than those on most drums. The finishes are top grade, including hand-rubbed lacquers. These are indeed rugged, beautiful drums that can be adjusted to sounds required on any job.

|      |       | Stain or<br>Lacquer | Pearl    |
|------|-------|---------------------|----------|
| 1118 | 14x18 | \$100.00            | \$125.00 |
| 1120 | 14x20 | 104.00              | 130.00   |
| 1122 | 14x22 | 108.00              | 135.00   |
| 1124 | 14x24 | 112.00              | 140.00   |

## "TUXEDO" BASS DRUMS

|      |       | Stain or<br>Lacquer | Pearl    |
|------|-------|---------------------|----------|
| 2328 | 14x18 | \$ 92.00            | \$115.00 |
| 2330 | 14x20 | 96.00               | 120.00   |
| 2332 | 14x22 | 100.00              | 125.00   |
| 2334 | 14x24 | 104.00              | 130.00   |



Photo Shows 14x22 in White Pearl





## Camco "PARADE MASTERS"

- CHROME
- 4-PLY SHELLS
- SNAP IN KEY HOLDER
- DELUXE STRAINER
- INTERNAL TONE CONTROL
- SEPARATE TENSION

### PARADE MASTER SNARE DRUM Complete with Drum Sticks and Slings

|     |       | Lacquer | Pearl   |
|-----|-------|---------|---------|
| 458 | 10x14 | \$72.50 | \$84.50 |
| 460 | 12x15 | 85.00   | 97.50   |
| 462 | 12x16 | 86.50   | 98.50   |

### PARADE MASTER TENOR DRUMS Complete with Beaters and Slings

|     |       | Lacquer | Pearl   |
|-----|-------|---------|---------|
| 464 | 10x14 | \$72.50 | \$84.50 |
| 466 | 12x15 | 85.00   | 97.50   |
| 468 | 12x16 | 86.50   | 98.50   |

### PARADE MASTER SCOTCH BASS DRUMS Complete with Slings and Beaters

|      |       | Lacquer  | Pearl    |
|------|-------|----------|----------|
| 1145 | 8x24  | \$112.00 | \$132.00 |
| 1146 | 10x24 | 112.00   | 132.00   |
| 1147 | 8x28  | 121.00   | 141.00   |
| 1148 | 10x28 | 121.00   | 141.00   |



Long Island Sunrisers

For inlaid hoops on lacquer drums add \$5.00  
Plastic heads furnished unless other specified  
Gut Snares \$2.00 Extra

## Camco "PARADE QUEEN"

- CHROME
- 4-PLY SHELLS
- SNAP-IN KEY HOLDER
- STREAMLINE CASINGS
- SEPARATE TENSION
- INTERNAL TONE CONTROL

### SNARE DRUMS complete with Sticks and Sling

|       |       |                     |         |
|-------|-------|---------------------|---------|
| 713-L | 10x14 | Lacquer or Mahogany | \$62.50 |
| 713-P | 10x14 | Choice of Pearl     | 75.00   |
| 716-L | 12x15 | Lacquer or Mahogany | 76.00   |
| 716-P | 12x15 | Choice of Pearl     | 85.50   |
| 718-L | 12x16 | Lacquer or Mahogany | 80.50   |
| 718-P | 12x16 | Choice of Pearl     | 90.00   |

### TENOR DRUMS complete with Tenor Sticks and Sling

|       |       |                     |         |
|-------|-------|---------------------|---------|
| 720-L | 10x14 | Lacquer or Mahogany | \$62.50 |
| 720-P | 10x14 | Choice of Pearl     | 75.00   |
| 722-L | 12x15 | Lacquer or Mahogany | 76.00   |
| 722-P | 12x15 | Choice of Pearl     | 85.50   |
| 724-L | 12x16 | Lacquer or Mahogany | 80.50   |
| 724-P | 12x16 | Choice of Pearl     | 90.00   |

### SCOTCH BASS DRUMS complete with Slings and Beaters

|        |       |                     |          |
|--------|-------|---------------------|----------|
| 3018-L | 8x24  | Lacquer or Mahogany | \$107.00 |
| 3018-P | 8x24  | Choice of Pearl     | 127.00   |
| 3020-L | 10x24 | Lacquer or Mahogany | 107.00   |
| 3020-P | 10x24 | Choice of Pearl     | 127.00   |
| 3022-L | 8x28  | Lacquer or Mahogany | 116.00   |
| 3022-P | 8x28  | Choice of Pearl     | 136.00   |
| 3024-L | 10x28 | Lacquer or Mahogany | 116.00   |
| 3024-P | 10x28 | Choice of Pearl     | 136.00   |



St. Joseph Military Academy  
La Grange, Ill.

## CAMCO DELUXE PEDAL

**"THE PEDAL OF  
PEERLESS PERFORMANCE"**

The vast number of "Big Names" who are using the Camco Deluxe Pedal is definite proof that it has stood the test of time and fully meets the exacting demands of the Modern Drummer.

Its mechanical perfection plus rugged construction are two of the chief reasons for its popularity.

Simplicity of adjustments eliminates guess-work and permits the Drummer to arrive at the desired feel, balance and flow; and with just the right amount of resistance that suits him best . . . This assures smooth, easy and fast action at all tempos.

Positively frictionless and quiet.

Here is the pedal that does not divert the mind, allowing the Drummer to put more emphasis on stick technique.

**5000 Split Footboard**  
\$24.50

**5000-S One Piece  
Footboard**  
\$24.50

Ball Bearings

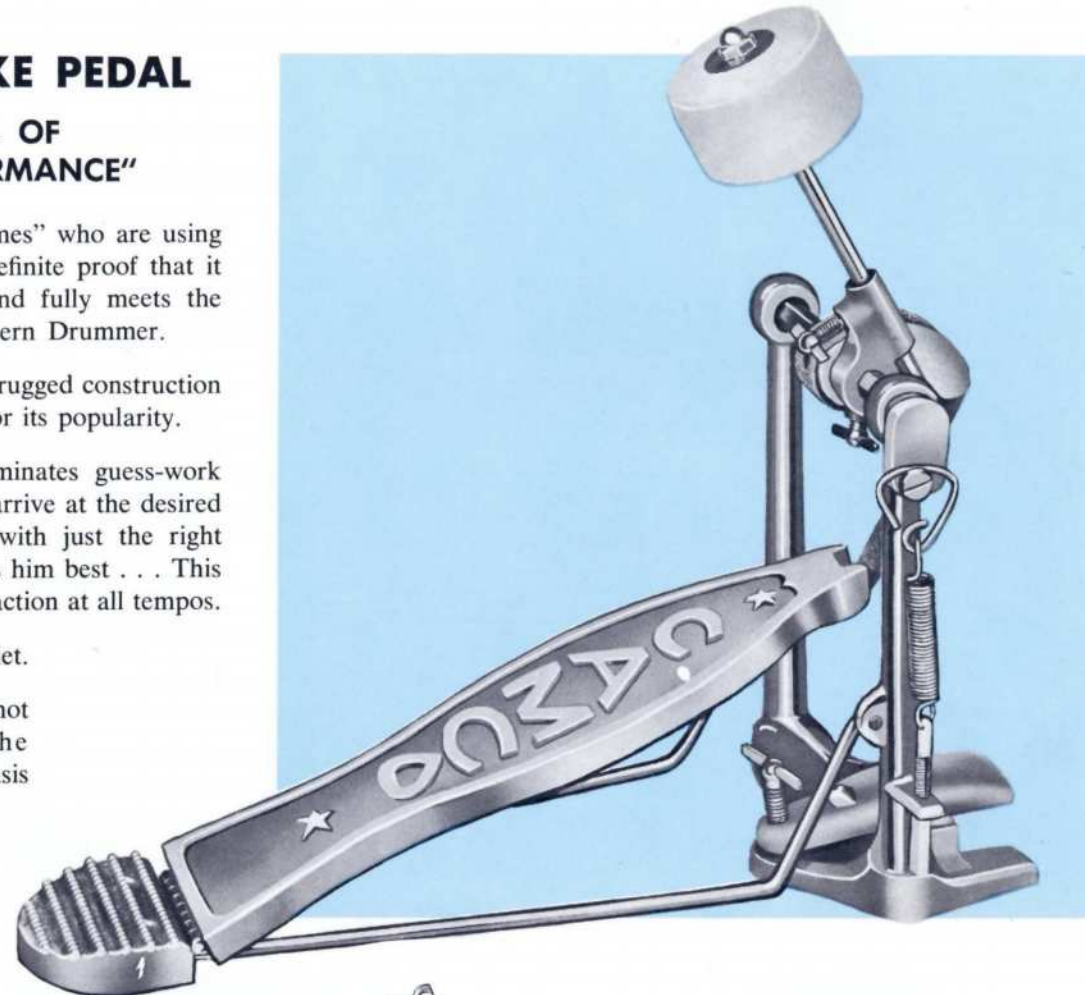

Polished aluminum and chromium-plated parts . . . equipped with solid felt beater ball unless otherwise specified . . . weighs only 3½ lbs. . . . folds easily and compactly without removing any parts whatever.

## CAMCO STANDARD PEDAL

**"Exceptional Efficiency in a Lower-Priced Model"**

Polished aluminum and baked enamel parts . . . equipped with cork beater ball . . . weighs 3½ lbs. . . . folds compactly without removing any parts.

**6000** . . . . . **\$18.95**  
Ball Bearings

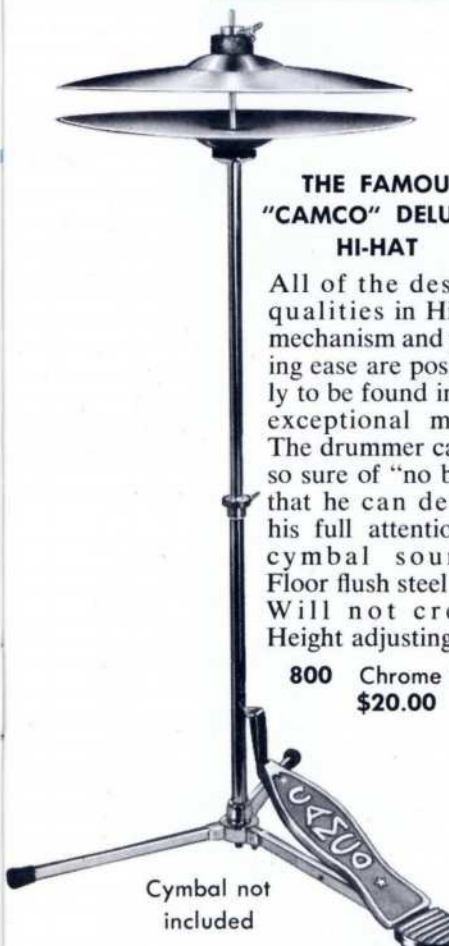

### THE FAMOUS "CAMCO" DELUXE HI-HAT

All of the desired qualities in Hi-Hat mechanism and playing ease are positively to be found in this exceptional model. The drummer can be so sure of "no bugs" that he can devote his full attention to cymbal sounds. Floor flush steel legs. Will not creep. Height adjusting.

**800** Chrome Only  
\$20.00

Cymbal not included

### NEW CAMCO DIRECT PULL HI-HATS

**500**  
**HI-HAT**  
split footboard  
\$33.50

**500-S**  
**HI-HAT**  
One Piece  
Footboard  
\$33.50

**900**  
**HI-HAT**  
split  
footboard  
\$33.50

**900-S**  
**HI-HAT**  
One Piece  
Footboard  
\$33.50

Newest improved Hi Hat on the market in both tripod and flush base. All features shown by arrows are included in both Hi Hats.

NEW IMPROVED  
CLUTCH

CYMBAL  
TILTING  
ADJUSTMENT

KNURL KNOB  
FOR SPRING ADJUSTMENT  
THAT CAN BE CHANGED AT  
WILL

LOCK SCREW  
FOR SPRING  
ADJUSTMENT KNOB

TWO HEAVY SPURS  
PREVENTS CREEPING

All Chrome Plated.



748



750

### CAMCO HI-HAT CLUTCH

Simple and efficient.

**748** . . . . . \$2.00

### CAMCO TILTER

Precision die cast, can't slip ratchet.

**750** Chrome . . . . . \$2.00

**751** Nickel . . . . . \$1.80



### WALBERG REGULAR HI-HAT

**502N** Nickel . . . . . \$15.00

**502C** Chrome . . . . . \$18.00



**CAMCO DELUXE CYMBAL STAND**

Tilter included. Modern and very practical cymbal stand. Light weight—Rigid, too. Has wide-spread folding steel legs. Extends to 48".

**700 Chrome Only — \$11.50**

Cymbal not included



**"CAMCO" FLUSH BASE DRUM STAND**

Folding legs open flush to floor. Ratchet angle adjustment. Extendable for standing position. A high quality stand.

**600 Chrome Only . . . \$12.80**

**BUCK ROGERS DRUM STAND FLUSH BASE**



**850 \$17.50**

**BUCK ROGERS DRUM STAND TRIPOD BASE**



**650 \$17.50**

**CAMCO PEDAL PRACTICE PAD**

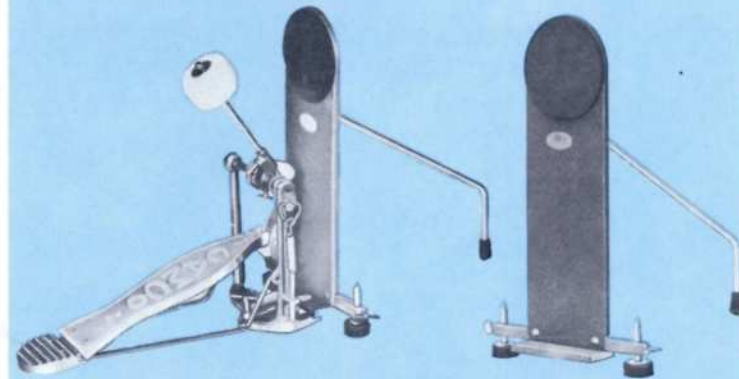

The importance of "foot work" in modern drumming equals that of stick technique. This practical pedal practice pad is the most advanced design made. It is well made of aluminum and steel parts, with a rubber disc beating surface. Takes up very little space. It will definitely improve "the beat."

**1000 . . . . . \$8.50**

**CAMCO THRONE**

Chrome Only. A steel screw through steel collar eliminates all possibilities of slipping.

Back rest \$2.25 extra.

**9000 . . . . . \$20.00**



**WALBERG THRONE**

An old reliable rigid model — Padded seat. Back rest \$2.25 extra.

**865-N Nickel . . . \$16.75**

**CYMBAL HOLDERS**

**— WOOD BLOCK & COW BELL HOLDERS**

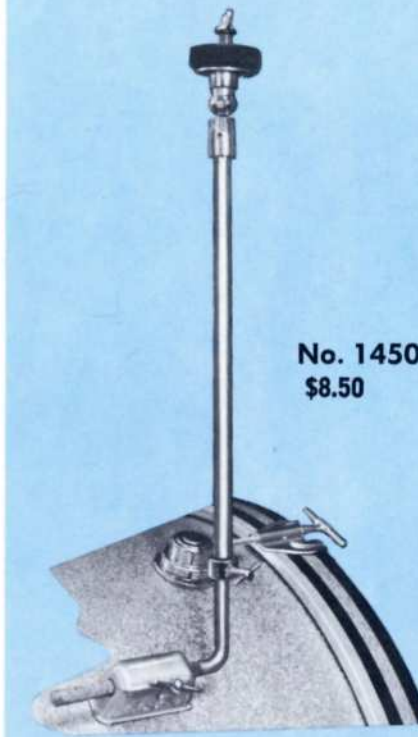

**No. 1450 \$8.50**

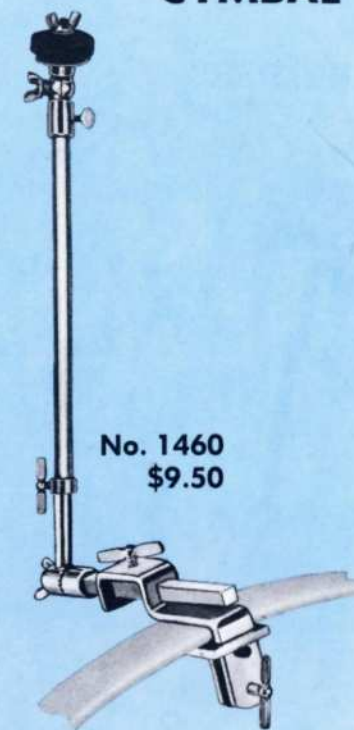

**No. 1460 \$9.50**



Disappearing shell mount cymbal holder. Chrome. **No. 1440 . . . \$5.00**

Height adjusting telescope cymbal sleeve. Chrome Only. **No. 1445 4.50**

Tilters included



**SINGLE COW BELL HOLDER**

**1422 With 1 clamp . . . . . \$3.00**



**DOUBLE COW BELL AND WOOD BLOCK HOLDER**

A new and more efficient set-up for cow bells and wood block. Ideal for Latin numbers and all other effects. Placed higher than other models . . . better for speed and comfort. No extra reaching.

**1420- Chromium AAA . . . . . \$5.70**



**COW BELL CLAMP**

Prevents bell from turning.

**1431 Chrome . . . . . 70¢**



**BRUSH CYMBAL HOLDER**

A new high post model. Cymbal is placed higher for less reaching and it has the extra strong "Camco" hoop clamp.

**1428- Chromium AAA . . . . . \$2.90**



**WOOD BLOCK HOLDER**

Block is held at both ends. No swinging out of place. The "Camco" hoop clamp really holds.

**1424- Chromium AAA . . . . . \$3.80**

# TOM-TOM HOLDERS

## CAMCO NEW MODERN SWIVEL TOM-TOM HOLDERS

Made From All Machine Parts  
No Castings to Break  
Chrome Plated



15 Single Swivel Tom-Tom Holder ..... \$18.00



18 Double Swivel Tom-Tom Holder ..... \$25.00

19 Double Swivel Tom-Tom Holder  
Mounted on Stand ..... \$30.00

## THE CONSOLE TOM-TOM HOLDER



A popular model which has full adjustments. Well made and very strong.

- 1435-C Chrome ..... \$13.50
- 1435-N Nickel ..... \$10.50
- 1435-CD Chrome Double  
Tom-Tom Holder ..... \$20.00

## DOUBLE TOM-TOM HOLDER



14 Double Tom-Tom Holder..... \$20.00

16 Double Tom-Tom  
Holder on Stand ..... \$24.00

## DISAPPEARING SPURS

Shell Mount, rubber tips included. The square rods are arched and point straight to the floor. They slide in a square notch in the round housing - cannot turn. More floor spread than others. Made of all strong machine parts to stand heavy wear and to last. Can be mounted straight to the floor or can be mounted to tilt forward.

1480 Pair, Chrome ..... \$7.50

## DISAPPEARING SPURS

Shell Mount, round steel rods slide in and out of bass drum shell. Can be used with either rubber or pointed tip.

1705 Pair, Chrome ..... \$5.00

## REGULATION SPURS

Hoop Mount. Equipped with 3 1/2" spikes. Often used as extras for additional assurance against creeping on uneven floors.

1542 Pair, Nickel Only ..... \$1.40

## BASS DRUM ANCHOR

Hoop Mount. Hoop clamp with two reversible spurs. Can use either steel points or rubber tips.

1601 Chrome ..... \$5.50

1602 Nickel ..... 4.50

## STICK-FAST SPUR ANCHORS

For all Model Spurs. Spurs fit into metal tubes which swivel in rubber cone bases. The sponge rubber floor grips will not creep.

1544 Pair ..... \$4.90

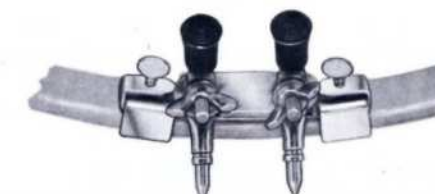
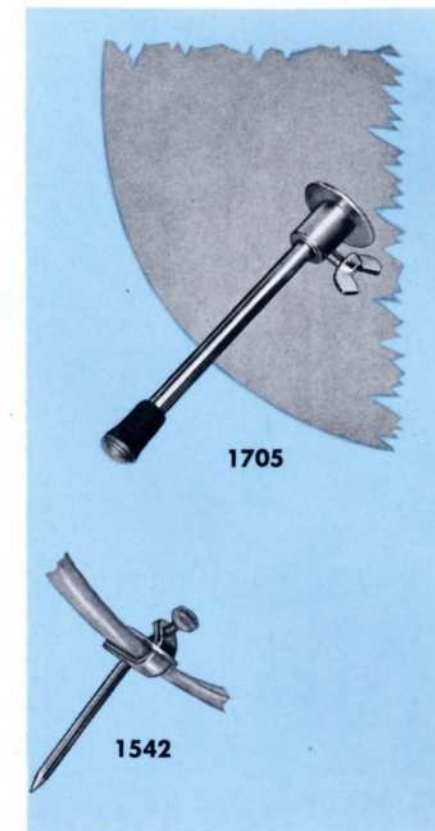

## PEDAL BEATER BALLS AND RODS FOR ALL SOUNDS

|   |   |   |  |   |
|---|---|---|--|---|
| <br><b>SOLID CORK</b><br>Solid sound<br>All-around work<br>250 — \$2.00 | <br><b>LAMB'S WOOL</b><br>Soft boom sound<br>Concert work<br>251 — \$3.00 | <br><b>THUMPER<br/>SQUARE<br/>AND<br/>TRIANGLE</b><br>New dimension<br>in sound<br>255 — \$3.50<br>each | <br><b>SOLID FELT</b><br>Medium sound<br>Most used<br>253 — \$3.00 | <br><b>SOLID WOOD</b><br>Rock and roll<br>and bombs<br>254 — \$2.00 |
|---|---|---|--|---|

# Camco HICKORY DRUM STICKS

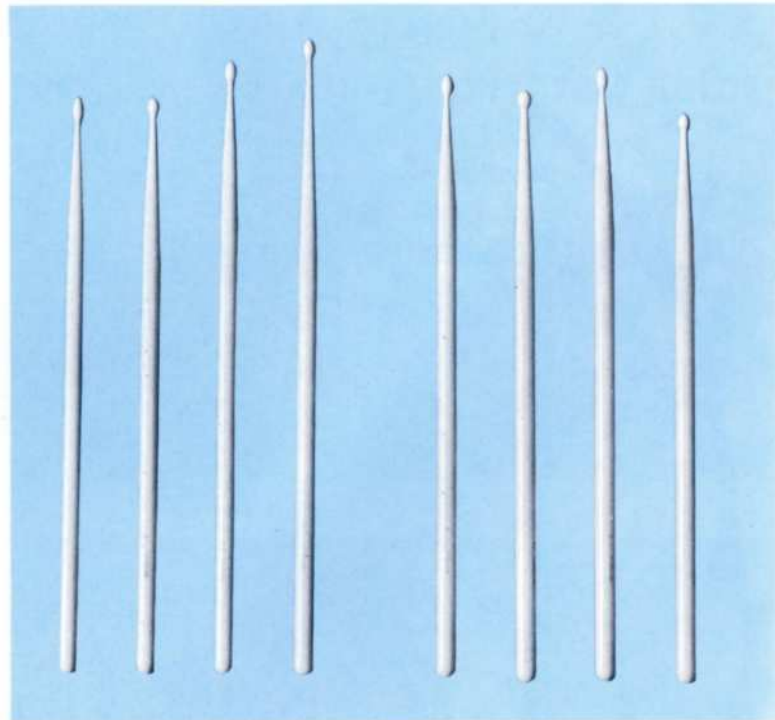

PEE WEE 7-A 0-8 1-A 2-A 3-A 5-A 6-A  
**JAZZ MODELS** Extra light weight  
 15" 15½" 16¼" 17"  
**DANCE AND SCHOOL MODELS** Light weight  
 15¾" 15½" 16" 15"

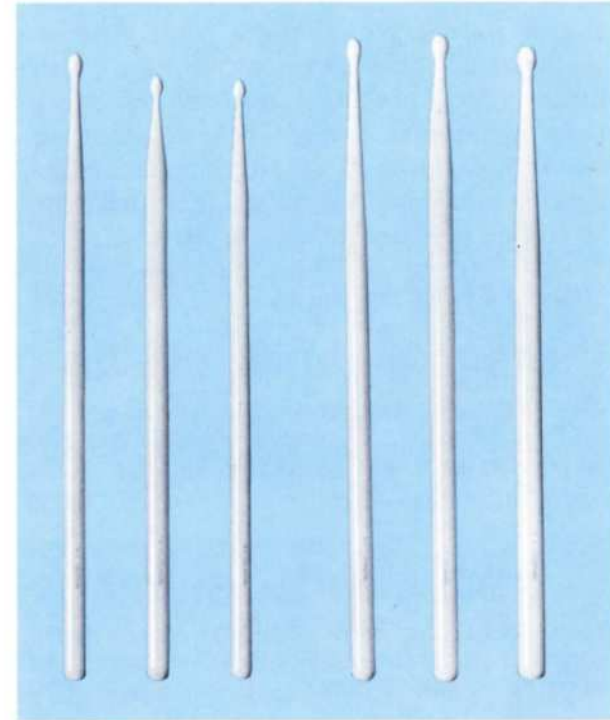

1-B 2-B 5-B 1-S 2-S 3-S  
**CONCERT MODELS** Medium weight  
 16½" 15¾" 16"  
**PARADE MODELS** Heavy weight  
 17" 17" 17½"

We invite drummers to compare our sticks with others. It will readily be noticed that these are "ultra" models. Two new extra operations have been added that have not been heretofore employed. The thoroughly dried hickory is the best obtainable and our workmanship shows in every stick. **\$1.40 pr.**

## NYLON TIP STICKS \$1.75 pr.



## PERSONALIZED HICKORY DRUM STICKS \$1.40 pr.



# Camco PRACTICE PADS

Gum Rubber on all Pads . . . Rubber Non-slip Feet . . . Red Glossy Enamel Finish

The "PROFESSIONAL" 9"x7"  
 1210 — \$5.00

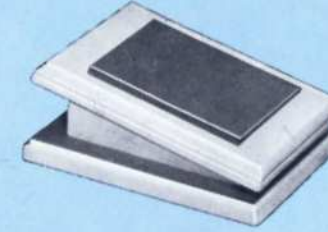

The "STANDARD" 8"x7"  
 1215 — \$3.00



The "HEAVY DUTY" 9"x7"  
 1212 — \$5.00

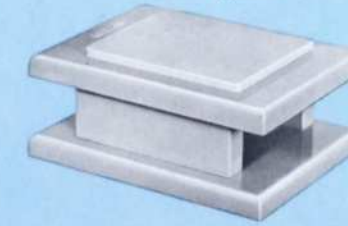

The 6" RUBBER DISC  
 1230 — \$1.50



## PRACTICE PAD

Has 6" Round Live Rubber Pad in Center. Protects Head in Case.

1100-14 for 14" DRUM  
 1100-15 for 15" DRUM

PRICE . . . . . \$3.00

## PRACTICE PAD STAND

1160 — Stand Only \$8.50

# Camco WIRE BRUSHES "The Choice of Most Professionals"



Rubber Covered Handles  
 Loop Ends  
 1070  
 Pair — \$1.75

Rubber Covered Handles  
 Ball Ends  
 1072  
 Pair — \$1.85

Plain Aluminum Handles  
 Loop Ends  
 1074  
 Pair — \$1.50

Plain Aluminum Handles  
 Ball Ends  
 1076  
 Pair — \$1.75

## CAMCO BASS DRUM STICKS

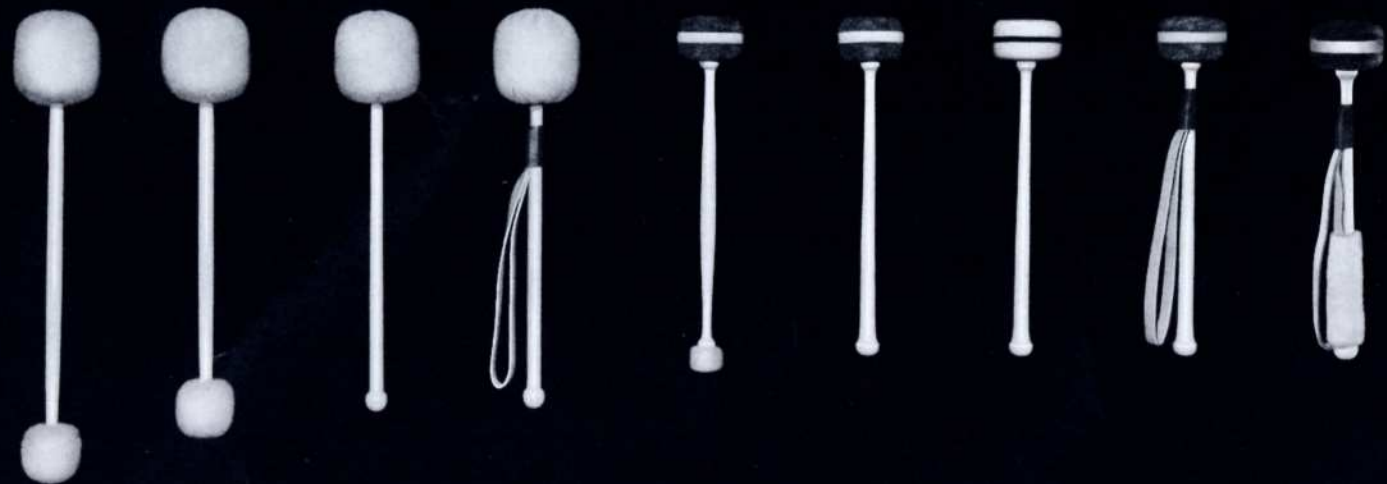

|   |  |   |  |  |  |   |   |  |
|---|--|---|--|--|--|---|---|--|
| Lamb's Wool<br>Double End<br>Extra Length<br>17½" Overall | Lamb's Wool<br>Double End<br>Regular Length<br>16" Overall | Lamb's Wool<br>Single End<br>Wood Grip<br>15" Overall | Lamb's Wool<br>Single End<br>With Sling<br>15" Overall | Felt Hi-Grade<br>Medium Hard<br>Double End<br>13½" Overall | Felt Hi-Grade<br>Medium Hard<br>Wood Grip<br>13" Overall | Felt Super Grade<br>Hard Wood Grip<br>13" Overall | Felt Hi-Grade<br>Medium Hard<br>With Sling<br>13" Overall | Felt Hi-Grade<br>Medium Wool<br>Grip With Sling<br>13" Overall |
| <b>1001</b>   | <b>1002</b>  | <b>1003</b>   | <b>1004</b>  | <b>1005</b>  | <b>1006</b>  | <b>1007</b>                                       | <b>1008</b>   | <b>1009</b>  |
| <b>\$5.50</b>   | <b>\$5.50</b>  | <b>\$5.00</b>   | <b>\$6.00</b>  | <b>\$4.50</b>  | <b>\$4.00</b>  | <b>\$4.50</b>                                     | <b>\$6.00</b>   | <b>\$6.50</b>  |

## SCOTCH BASS DRUM STICKS



|  |   |  |
|--|---|--|
| Lamb's Wool<br>Soft Leather<br>Thongs<br>14" Overall | Hi-Grade<br>Medium Hard Felt<br>Leather Thongs<br>14" Overall | Super Grade<br>Medium Hard Felt<br>Leather Thongs<br>14" Overall |
| <b>1012</b>  | <b>1014</b>   | <b>1016</b>  |
| <b>\$6.50</b>  | <b>\$5.50</b>   | <b>\$6.50</b>  |

## CAMCO TENOR DRUM STICKS

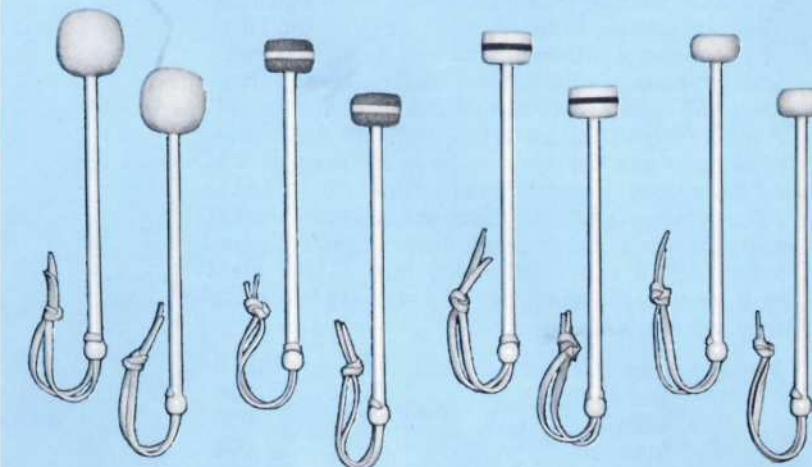

|                                    |   |  |                                      |
|------------------------------------|---|--|--------------------------------------|
| SOFT<br>Lamb's Wool<br>12" Overall | SEMI-HARD<br>Hi-Grade Felt<br>12" Overall | SEMI-HARD<br>Super-Grade Felt<br>12" Overall | SOLID<br>Medium Felt<br>11¾" Overall |
| <b>1020</b>                        | <b>1022</b>                               | <b>1023</b>                                  | <b>1024</b>                          |
| <b>\$6.00</b>                      | <b>\$5.50</b>                             | <b>\$6.00</b>                                | <b>\$5.50</b>                        |

## CAMCO TYMPANI STICKS

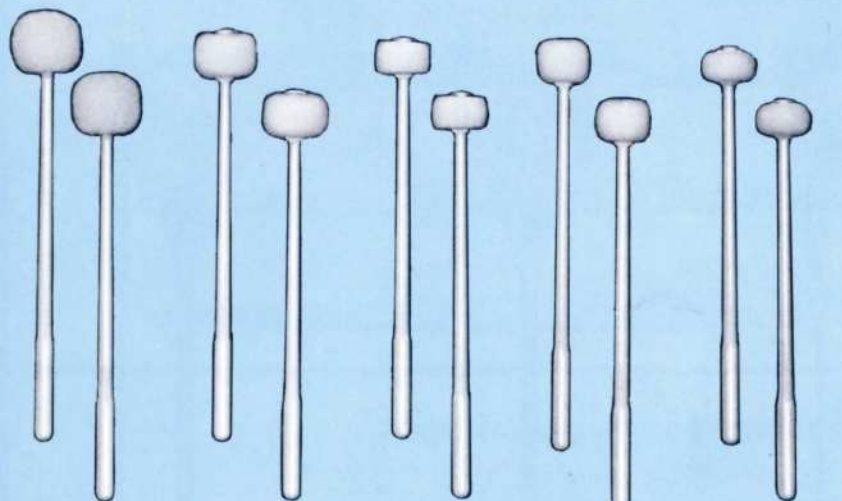

|                                       |                              |                         |                        |                                 |
|---------------------------------------|------------------------------|-------------------------|------------------------|---------------------------------|
| "ARTIST"<br>Lamb's Wool<br>Fixed Ball | "PROFESSIONAL"<br>Piano Felt | "CONCERT"<br>Piano Felt | "MIDGET"<br>Piano Felt | "HEAVI-TONE"<br>Solid Hard Felt |
| <b>1030</b>                           | <b>1032</b>                  | <b>1036</b>             | <b>1038</b>            | <b>1040</b>                     |
| <b>\$6.00 pr</b>                      | <b>\$5.50 pr</b>             | <b>\$5.50 pr</b>        | <b>\$5.50 pr</b>       | <b>\$5.00 pr</b>                |



### METAL HANDLES

LAMBS  
WOOL  
**930**  
**\$6.50**  
pr.



PIANO  
FELT  
**938**  
**\$6.00**  
pr.

SOLID  
FELT  
**940**  
**\$5.50**  
pr.

### Metal Handle Scotch Bass Drum Sticks



**916** ..... **\$7.50**

### Marshall Thompson All Purpose Sticks Soft Felt

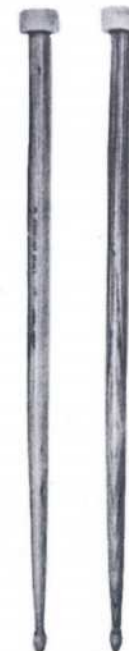

**\$3.00 pr.**

### Veri-Sonic Sticks



**6 Colors**  
**4 Models**  
Pencil  
Parade  
Orchestra  
Lt. Orchestra

**\$4.50 pr.**

### Nick Ceroli All Purpose Sticks Firm Felt



**\$3.00 pr.**

### Metal Handle Tenor Drum Sticks



**923** ..... **\$7.00 pr**

## AVEDIS ZILDJIAN CYMBALS

No other make of cymbal in the world has the wide endorsement of the Avedis Zildjian brand. They have that "something" in blare, brilliance and rich sounds that has never been equalled. That, of course, is the reason the great majority of professional drummers, as well as concert band and symphony orchestra conductors, choose them above all others both in this country and abroad. Avedis Zildjian and his sons—Bob and Armand—personally mix the secret alloy in a closely-guarded laboratory, just as it was formulated in 1623. After casting they are fired, hammered, shaped and tempered many times under high temperatures. All of this (and much more) plus great skill, assures the resonance and strength for which they are world-famous.

|                                   |     |        |
|-----------------------------------|-----|--------|
| Please specify thickness desired. | 8"  | 10.00B |
| Extra Thin                        | 10" | 17.00B |
| Thin                              | 12" | 27.00B |
| Medium                            | 13" | 32.00B |
| Medium Heavy                      | 14" | 36.00B |
| Heavy                             | 15" | 40.00B |
|                                   | 16" | 45.00B |
|                                   | 17" | 50.00B |
|                                   | 18" | 55.00B |
|                                   | 19" | 60.00B |
|                                   | 20" | 65.00B |
|                                   | 21" | 75.00B |
|                                   | 22" | 77.50B |
|                                   | 24" | 90.00B |

We carry a large stock of all sounds . . . If you will describe the usage intended — and size of organization—we will be glad to make careful personal selections.

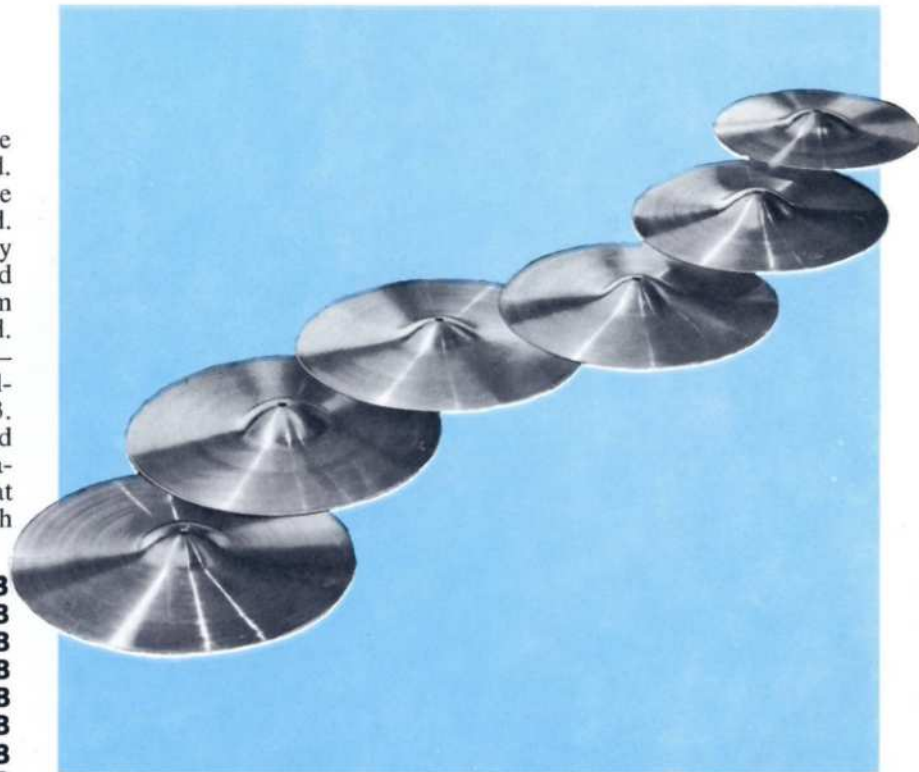

### AVEDIS ZILDJIAN SIZZLE CYMBALS



Exactly the same cymbals as the Avedis Zildjian listed above, with sizzle rivets added. Use the same prices for the same size. Please state number of rivets desired.

### AVEDIS ZILDJIAN GONGS AND STANDS

Cast of Zildjian Metal. Deep, rich, powerful, realistic gong tones.

|     |          |
|-----|----------|
| 20" | \$70.00B |
| 22" | 80.00B   |
| 24" | 110.00B  |
| 26" | 130.00B  |
| 28" | 160.00B  |

1592 Gong Stand. Folding Legs.  
Ring Made to Order.  
State Size .....\$30.00

### KRUT CYMBALS - ENGLISH IMPORTS

|     |        |
|-----|--------|
| 12" | \$7.30 |
| 13" | 9.10   |
| 14" | 11.40  |
| 15" | 13.00  |
| 16" | 15.00  |
| 18" | 22.00  |
| 20" | 31.70  |
| 22" | 40.70  |

For Rivets in Cymbal — add \$2.00



### THE CORRECT WAY TO TIE A CYMBAL KNOT

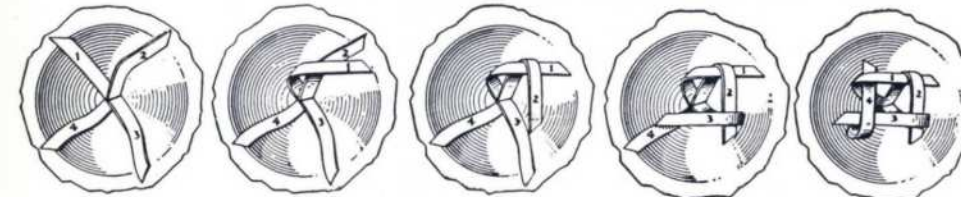

Lay the four leather ends flat in the cymbal cup

Fold No. 1 to the right and over No. 2

Fold No. 2 downward and over No. 1

Fold No. 3 to the left and over No. 2

Fold No. 4 upward over No. 3 and under No. 1. Pull ends tight.

### WOOD CYMBAL HANDLES

249 Pair .....\$2.25



## CHING-RING



CHING-RING  
7" STEEL SOUND-RESONATING RING  
8 pr. QUALITY CHINGLES  
ADJUSTABLE STEEL STRAP  
FINE FINISH  
\$9.95

## CYMBAL STRAPS AND PADS

These cymbal straps and pads are cut with "a little extra" in length, width, and thickness—a little larger than most models. This gives longer wear and is a great assist in overcoming fatigue and the tempo problem. Made of top grain "pearl elk" leather. Note that we supply knot washers.

### REGULATION

|      |                    |        |
|------|--------------------|--------|
| 1051 | Straps, Pair ..... | \$1.80 |
| 1052 | Pads, Pair .....   | 2.50   |

### LAMB'S WOOL COVERED

|      |                    |        |
|------|--------------------|--------|
| 1054 | Straps, Pair ..... | \$3.50 |
| 1056 | Pads, Pair .....   | 6.00   |

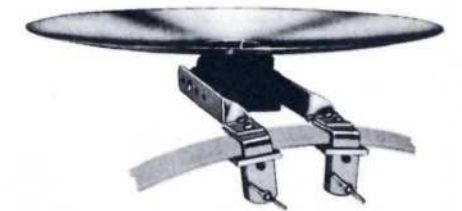

### BAND CYMBAL HOLDER

Heavy extra strong holder with two "Camco" hoop clamps that prevent slipping.

1427 Chromium AAA ..... \$6.50

### GREEKO CYMBALS



Nickel Silver—3½" and 3¼" with hoop clamp.

222 Pair ..... \$4.50 pr.

### FINGER CYMBALS



Brass alloy. Highly polished. The tones are brilliant. 2½" diameter.

220 Set of 4 ..... \$5.70 set

### CAMCO'S NEW ADJUSTABLE THROW OFF CYMBAL SIZZLER

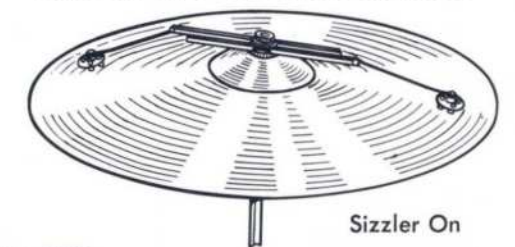

Sizzler On

No. 730  
Price \$3.60

Patent No.  
3,009,379

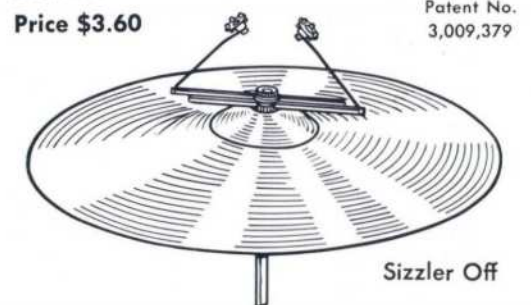

Sizzler Off

## PLASTIC DRUM HEADS

CRISP, EASY PLAYING,  
EVEN TENSION DRUMS  
ASSURED... RAIN OR SHINE

Thousands now in use among leading professionals and in the schools.

### CAMCO TOM-TOM OR BATTER SIDE

|                    |        |
|--------------------|--------|
| For 12" Shell..... | \$7.50 |
| For 13" Shell..... | 7.50   |
| For 14" Shell..... | 7.50   |
| For 15" Shell..... | 7.50   |
| For 16" Shell..... | 7.50   |

### CAMCO SNARE SIDE

|                    |        |
|--------------------|--------|
| For 13" Shell..... | \$6.50 |
| For 14" Shell..... | 6.50   |
| For 15" Shell..... | 6.50   |
| For 16" Shell..... | 6.50   |

### TYMPANI

|           |         |
|-----------|---------|
| 25" ..... | \$21.00 |
| 28" ..... | 24.00   |

### WEATHER KING BATTER SIDE OR TOM-TOM

|                    |        |
|--------------------|--------|
| For 13" Shell..... | \$7.00 |
| For 14" Shell..... | 7.50   |
| For 15" Shell..... | 8.00   |
| For 16" Shell..... | 8.50   |

### WEATHER KING SNARE SIDE

|                    |        |
|--------------------|--------|
| For 13" Shell..... | \$6.00 |
| For 14" Shell..... | 6.50   |
| For 15" Shell..... | 7.00   |
| For 16" Shell..... | 7.50   |

### CAMCO BASS DRUM

|                    |         |
|--------------------|---------|
| For 18" Shell..... | \$15.00 |
| For 20" Shell..... | \$17.00 |
| For 22" Shell..... | 18.00   |
| For 24" Shell..... | 19.00   |
| For 26" Shell..... | 21.00   |
| For 28" Shell..... | 22.00   |
| For 30" Shell..... | 23.00   |
| For 32" Shell..... | 25.00   |

Please Order by Size of Drum Shell Only

## WHITE CALF DRUM HEADS

Specify - Orchestra, Parade or Tom-Tom

### BATTER SIDE

|                         | Unmounted  | Mounted     |
|-------------------------|------------|-------------|
| 16" for 12" shell ..... | B16 \$7.50 | MB16 \$9.40 |
| 17" for 13" shell ..... | B17 8.00   | MB17 10.00  |
| 18" for 14" shell ..... | B18 8.70   | MB18 10.70  |
| 19" for 15" shell ..... | B19 9.80   | MB19 11.80  |
| 20" for 16" shell ..... | B20 10.80  | MB20 12.80  |
| 23" for 18" shell ..... | B23 14.00  | MB23 16.00  |
| 25" for 20" shell ..... | B25 21.00  | MB25 28.00  |

### SNARE SIDE - TRANSPARENT

|                         | Unmounted  | Mounted     |
|-------------------------|------------|-------------|
| 17" for 13" shell ..... | S17 \$6.30 | MS17 \$8.30 |
| 18" for 14" shell ..... | S18 6.80   | MS18 8.80   |
| 19" for 15" shell ..... | S19 7.00   | MS19 9.00   |
| 20" for 16" shell ..... | S20 7.20   | MS20 9.20   |
| 21" for 17" shell ..... | S21 7.70   | MS21 9.70   |
| 22" for 18" shell ..... | S22 8.20   | MS22 10.20  |

### BASS DRUM HEADS

|                         | Unmounted   | Mounted      |
|-------------------------|-------------|--------------|
| 23" for 18" shell ..... | B23 \$14.00 | MB23 \$21.00 |
| 25" for 20" shell ..... | B25 21.00   | MB25 28.00   |
| 27" for 22" shell ..... | B27 23.00   | MB27 30.00   |
| 29" for 24" shell ..... | B29 24.30   | MB29 31.30   |
| 31" for 26" shell ..... | B31 27.30   | MB31 34.30   |
| 33" for 28" shell ..... | B33 30.30   | MB33 37.30   |
| 35" for 30" shell ..... | B35 32.00   | MB35 39.00   |
| 37" for 32" shell ..... | B37 34.00   | MB37 41.00   |
| 39" for 34" shell ..... | B39 36.80   | MB39 43.80   |
| 41" for 36" shell ..... | B41 39.00   | MB41 46.00   |

## PLASTIC BANJO HEADS

|           |        |
|-----------|--------|
| 11" ..... | \$8.00 |
|-----------|--------|

## REMO TUNABLE PRACTICE PADS

Tension them like a drum, they feel like a drum, provide a realistic approach to the development of superior all around drum techniques.

|                    |         |
|--------------------|---------|
| Model RT 6" .....  | \$6.50* |
| Model RT 8" .....  | 8.50*   |
| Model RT 10" ..... | 10.50*  |



### REMO VERSATILIC DRUM PRACTICE SET

Model RPS 10 - \$70.00B



1200



1048



23

26

No. 114

355

4447

4453

1290

## BASS DRUM RACK

Over 1,000 high school, college and professional bass drummers are now using this—the top prize winner of all bass drum racks. Many have voluntarily stated that it is the strongest and best looking rack they have ever seen. Made of 1" diameter steel tubing instead of the usual 3/4" size. All chrome plated. It also opens wider and will accommodate the largest drums.

1200 Chrome .....\$21.00

## SOLID WOOD BASS DRUM BEATERS

Solid rock maple. Natural lacquer finish. Usually used in pairs for the loud rudimental beats on parade. 12 1/2" Overall.

1048 Each .....\$2.50

## ACME DRUM MAJOR WHISTLES

All Metal—Easy Blow and Very Loud.

23 Small ..... 1.65

26 Large ..... 2.00

## KEY HOLDER

Mounts in Shell — Always handy.

No. 114 .....\$1.00

## PARADE DRUM EYE FOR SLING SNAP HOOK

Fits under square head rod.

355 Chrome .....40¢

356 Bass Drum Hook.....\$1.00

## WEB DRUM SLINGS

2" stout webbing. Fine Hardware.

### SNARE DRUM

4447 White ..... 2.60

### BASS DRUM

4453 White ..... 5.00

### COMBINATION WRENCH and KEY

1290 ..... 1.50



## PARADE LEG REST

Self-aligning adjustment. Keeps drum from swaying.

4434 Nickel .....\$4.80

4437 Chrome ..... 6.75



### CAMCO DRUM KEY

1275 .....50¢

- Extra Heavy
- Extra Strong

### NEW SPEED KEY

1280 .....\$1.50

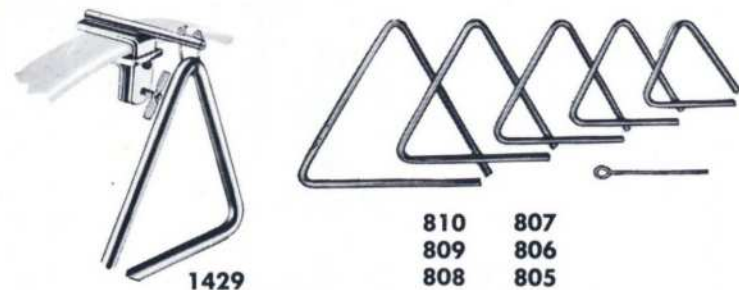

### TRIANGLE HOLDER

You can be sure that this extra strong holder will remain in place. Gut suspension cord.  
**1429-Chromium AAA** .....\$2.50

### TRIANGLES

Fine grade steel. Brilliant tones. Heavily plated. Striker included.

|     |     |             |     |    |             |
|-----|-----|-------------|-----|----|-------------|
| 810 | 10" | .....\$3.15 | 807 | 7" | .....\$1.85 |
| 809 | 9"  | .....2.60   | 806 | 6" | .....1.60   |
| 808 | 8"  | .....2.10   | 805 | 5" | .....1.40   |

### ONE COW BELL HOLDER

**429-C** Chrome .....\$2.00    **429-N** Nickel .....\$1.20

### TWO COW BELL HOLDER

**430-C** Chrome .....\$3.00    **430-N** Nickel .....\$2.40

### WOOD BLOCK HOLDER

**1541-C** Chrome .....\$1.35    **1541-N** Nickel .....\$1.00

### WOOD BLOCK AND COW BELL HOLDER

**443-C** Chrome .....\$2.70  
**443-N** Nickel .....1.95

### TIMBALE WOOD BLOCK AND COW BELL HOLDER

**1663-C** Chrome .....\$3.25  
**1663-N** Nickel .....2.50

### INTERNAL SNARE DRUM MUFFLER

Only Vertical Control on Market. Very Fast.  
**1115** .....\$3.00

### CAMCO BASS DRUM MUFFLER

This new idea bass drum muffer has risen to a top favorite in six months time. No springs to deteriorate or rust. The pressure adjustment is directly in center of felt disc. Any color pearl to match your drums. Your choice of Pearls. Please state pearl desired.

**1426P** All Metal parts chrome plated .....\$6.00  
**1426C** Chrome Disc .....6.00  
**1430** 3" x 25" Bass Felt Muffer .....\$1.00

## "SNAPPI" COILED WIRE SNARES

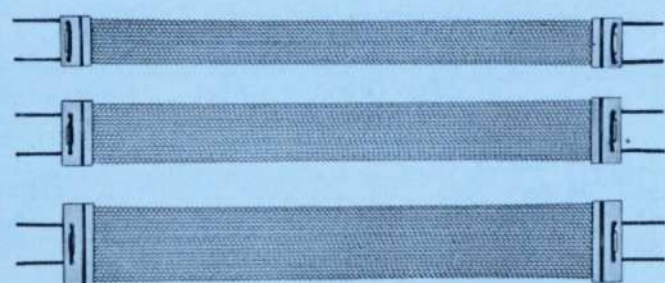

|             |                              |               |
|-------------|------------------------------|---------------|
| <b>1240</b> | 12 Strand for 13" Drums..... | <b>\$3.00</b> |
| <b>1241</b> | 12 Strand for 14" Drums..... | <b>3.00</b>   |
| <b>1242</b> | 12 Strand for 15" Drums..... | <b>3.00</b>   |
| <b>1245</b> | 16 Strand for 14" Drums..... | <b>3.30</b>   |
| <b>1247</b> | 16 Strand for 15" Drums..... | <b>3.30</b>   |
| <b>1250</b> | 20 Strand for 14" Drums..... | <b>3.50</b>   |
| <b>1251</b> | 20 Strand for 15" Drums..... | <b>3.50</b>   |
| <b>1252</b> | 16 Strand for Super .....    | <b>4.50</b>   |

## Camco MALLETS



|                       |                      |                         |                         |                       |                        |                      |                           |                              |
|-----------------------|----------------------|-------------------------|-------------------------|-----------------------|------------------------|----------------------|---------------------------|------------------------------|
| <b>C-1</b>            | <b>C-2</b>           | <b>C-3</b>              | <b>C-4</b>              | <b>C-5</b>            | <b>692</b>             | <b>C-6</b>           | <b>C-7</b>                | <b>C-8</b>                   |
| 1" Soft Yellow Rubber | 1" Medium Red Rubber | 1" 1/2 Hard Blue Rubber | 1" 3/4 Hard Gray Rubber | 1" Hard White Plastic | 3/4" Solid Brass Balls | 1 1/8" Hard Red Yarn | 1 1/8" 1/2 Hard Blue Yarn | 1 1/8" Med. Soft Yellow Yarn |
| <b>\$2.20</b>         | <b>\$2.20</b>        | <b>\$2.20</b>           | <b>\$2.20</b>           | <b>\$2.50</b>         | <b>\$1.50</b>          | <b>\$4.50</b>        | <b>\$4.50</b>             | <b>\$4.50</b>                |

**C-1** Ideal for practice and 4 mallet playing  
**C-2** Excellent for ensemble and solo  
**C-3** For greater volume  
**C-4** For Xylophone and bells  
**C-5** For Xylophone and bells  
**692** For Bells metallic effect  
**C-6** For Vibe and Marimba - 2, 3, and 4 mallets  
**C-7** Special for Vibe - 2, 3, and 4 mallets  
**C-8** For Marimba - 2, 3, and 4 mallets

## BELL-LYRA MALLETS



New balance assures accurate aim—positively guaranteed unbreakable balls. The strongest mallets ever made. You can be sure that the balls will not break. Shafts are of 1/8" special alloy carbon magnesium steel made to our order. The hand grips are semi-hard ribbed rubber. These exclusive features provide a new feel and balance that means better control and therefore better playing technique. One of the most outstanding inventions ever presented in the percussion dept. They are slightly higher in cost because of better materials and workmanship, but they will outlast dozens of the old style models, therefore are much cheaper in the long run.

**1050** Pair .....\$3.80



## BELL-LYRAS AND STAND

Made in 3 sizes

All models 25 bars each. Tapered tubular steel chrome plated frames, plumes, sling, mallet and cover included.

**The "EL CAPITAN"**  
 Bars—1 1/4"x3/8". Weight—12 lbs. Height—28".  
**300** .....\$135.00

**The "DRESS PARADE"**  
 Bars—1 1/4"x5/16". Weight—10 1/2 lbs. Height—26".  
**330** .....\$117.00

**The "AMERICAN PATROL"**  
 Bars—1"x1/4". Weight—7 lbs. Height—24".  
**310** .....\$96.50

**BELL-LYRA STAND**  
 Folding and with tilting adjustment.  
**1477N** Nickel .....\$18.00  
**1477C** Chrome .....22.00

## LEATHER BELL-LYRA SLINGS

Fine top-grain sole leather.

|         |                         |                |
|---------|-------------------------|----------------|
| Single, | <b>4855</b> White ..... | <b>\$12.50</b> |
|         | <b>4853</b> Tan .....   | <b>10.30</b>   |
| Double, | <b>4857</b> White ..... | <b>18.50</b>   |
|         | <b>4856</b> Tan .....   | <b>12.00</b>   |



No. 21

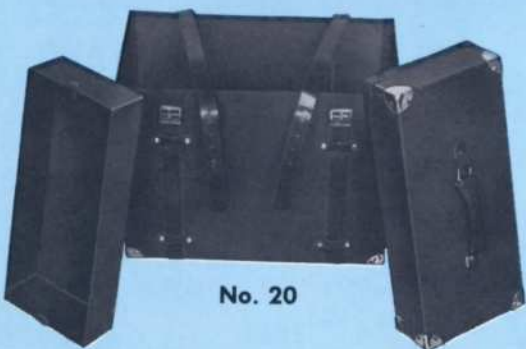

No. 20



No. 40



No. 30



SQUARE SNARE

TELESCOPE FIBRE CASES

### ZIPPER DRUM COVERS

All sizes are shell measurements only — allowance is made for hoops. Please state type and size when ordering.

#### SNARE DRUM

|       | Mack-intosh | Dura-lyte |       | Mack-intosh | Dura-lyte |
|-------|-------------|-----------|-------|-------------|-----------|
| 4x13  | \$7.80      |           | 5½x14 | \$7.80      | \$9.20    |
| 4½x14 | 7.80        |           | 6½x14 | 7.80        | 9.20      |
| 5x14  | 7.80        | 9.20      | 8x15  | 7.80        | 10.05     |

#### PARADE DRUM

|       | Mack-intosh | Dura-lyte |       | Mack-intosh | Dura-lyte |
|-------|-------------|-----------|-------|-------------|-----------|
| 10x14 | \$8.40      | \$10.50   | 12x15 | \$9.00      | \$10.05   |
| 10x15 | 8.70        | 10.50     | 12x16 | 9.00        | 10.05     |

#### TOM-TOM

|      | Mack-intosh | Dura-lyte |       | Mack-intosh | Dura-lyte |
|------|-------------|-----------|-------|-------------|-----------|
| 8x12 | \$8.10      | \$9.20    | 14x14 | \$9.00      | \$10.50   |
| 9x13 | 8.10        | 9.20      | 16x16 | 9.00        | 11.10     |

#### BASS DRUM

|       | Mack-intosh | Dura-lyte |       | Mack-intosh | Dura-lyte |
|-------|-------------|-----------|-------|-------------|-----------|
| 14x18 | \$13.00     | \$15.10   | 10x28 | \$16.00     | \$18.90   |
| 14x20 | 13.50       | 15.10     | 14x24 | 14.25       | 18.90     |
| 14x22 | 13.50       | 15.10     | 14x28 | 15.90       | 18.90     |

#### DURALYTE CYMBAL BAGS

|             | Mack-intosh | Dura-lyte |             | Mack-intosh | Dura-lyte |
|-------------|-------------|-----------|-------------|-------------|-----------|
| 13" and 14" | \$12.30     |           | 15" and 16" | \$12.90     |           |
| 18"         | 13.80       |           | 20"         | 15.00       |           |
| 22"         | 15.80       |           | 24"         | 17.60       |           |

### FIBRE CASES

#### SUPER CARRY-ALL CASE

|   |          |
|---|----------|
| No. 21 Extra Large. Will hold 22" Cymbal has tray and partition | \$42.65B |
| No. 21-W Same but with wheels                                   | 50.60B   |

#### REGULATION CARRY-ALL CASE

|   |        |
|---|--------|
| No. 20 Has tray and partition Will hold 15" Cymbal and extras | 31.35B |
|---|--------|

#### STUDENT CASE

|                    |       |
|--------------------|-------|
| Deluxe Case - Blue | 16.95 |
|--------------------|-------|

#### TRAY FRAME CASE

|  |          |
|--|----------|
| No. 40 Metal edge frame will hold 16" Cymbal | \$31.90B |
|--|----------|

#### PLAIN FIBRE CASE

|  |          |
|--|----------|
| No. 30 Plain edge frame will hold 16" Cymbal | \$25.80B |
|--|----------|

#### TELESCOPE SNARE DRUM

|   |          |                |          |
|---|----------|----------------|----------|
| Will take drums up to 8" shell depth 14" dia. shell | \$15.30B | 15" Dia. shell | \$15.50B |
|---|----------|----------------|----------|

#### PARADE DRUM

|       |          |       |          |
|-------|----------|-------|----------|
| 10x14 | \$18.05B | 12x16 | \$20.80B |
| 12x15 | 20.00B   |       |          |

#### TOM-TOM

|      |          |       |        |
|------|----------|-------|--------|
| 8x12 | \$15.95B | 14x14 | 20.10B |
| 9x13 | 16.50B   | 16x16 | 21.45B |

#### BASS DRUM

|       |          |       |          |
|-------|----------|-------|----------|
| 14x18 | \$28.05B | 14x26 | \$38.50B |
| 14x20 | 36.50B   | 14x28 | 39.50B   |
| 14x22 | 36.75B   | 10x28 | 38.50B   |
| 14x24 | 37.60B   |       |          |

|                  |          |
|------------------|----------|
| SQUARE SNARE 14" | \$13.10B |
|------------------|----------|

## REPLACEMENT PARTS LIST

#### STRAINERS

|                         |        |
|-------------------------|--------|
| 830 Aristocrat Strainer | \$9.50 |
| 845 Economy Strainer    | 4.50   |
| 841 Snare Jaw           | 1.00   |

#### TENSION CASINGS

|  |        |
|--|--------|
| 846 Aristocrat Snare Casings                 | \$1.20 |
| 847 Aristocrat Bass Casings                  | 1.40   |
| 848 Tuxedo Snare Casings                     | 1.20   |
| 849 Tuxedo Bass Casings                      | 1.40   |
| 851 Collar Screw Hoop for Single Flange Hoop | .40    |
| 852 Claw Hook for Bass Drums                 | .80    |
| 853 Claw Hook for Parade Drum                | .80    |
| 856 Casing for Cymbal Holder or Tom Tom Legs | 1.50   |
| 854 Tympani Handle Rods (State Size)         | .90    |

#### HI-HAT PARTS

|   |       |
|---|-------|
| 800-202 Leather Strap                   | \$.45 |
| 800-1 Spring                            | .30   |
| 800-2 Round Felt Washer                 | .16   |
| 800-3 Round Steel Washer                | .20   |
| 800-4 Round Washer and Bushing          | .30   |
| 800-5 Base Casting                      | 2.00  |
| 800-6 Large Wing Screw for Base         | .60   |
| 800-7 Strap Screw                       | .20   |
| 800-8 Hex Leg for Heel                  | .10   |
| 800-9 Crutch Tip for Leg on Heel        | .10   |
| 800-10 Rubber Bumper and Screw for Heel | .10   |
| 800-11 Footboard Connection             | 1.00  |
| 800-12 Metal Hinge                      | .45   |
| 800-14 ¼-20 Wing Screw Wide Spread      | .34   |
| 800-15 ¼-20 Wing Screw                  | .25   |
| 800-16 5/16-24 Wing Screw               | .34   |
| 800-17 Clamp for Top Tube               | .50   |

#### CRUTCH TIPS AND MISCELLANEOUS PARTS

|  |       |
|--|-------|
| 1200-1 1" I.D. Tip for Bass Drum Rack    | \$.30 |
| 800-13 Crutch Tip for 800-600-700 Stands | .10   |
| 9000-2 ¾" I.D. for Throne and Spurs      | .10   |
| 9000-1 Locking Ring and Screw for Throne | .80   |
| 600-6 Large Knurl Nut for 600 Drum Stand | .40   |

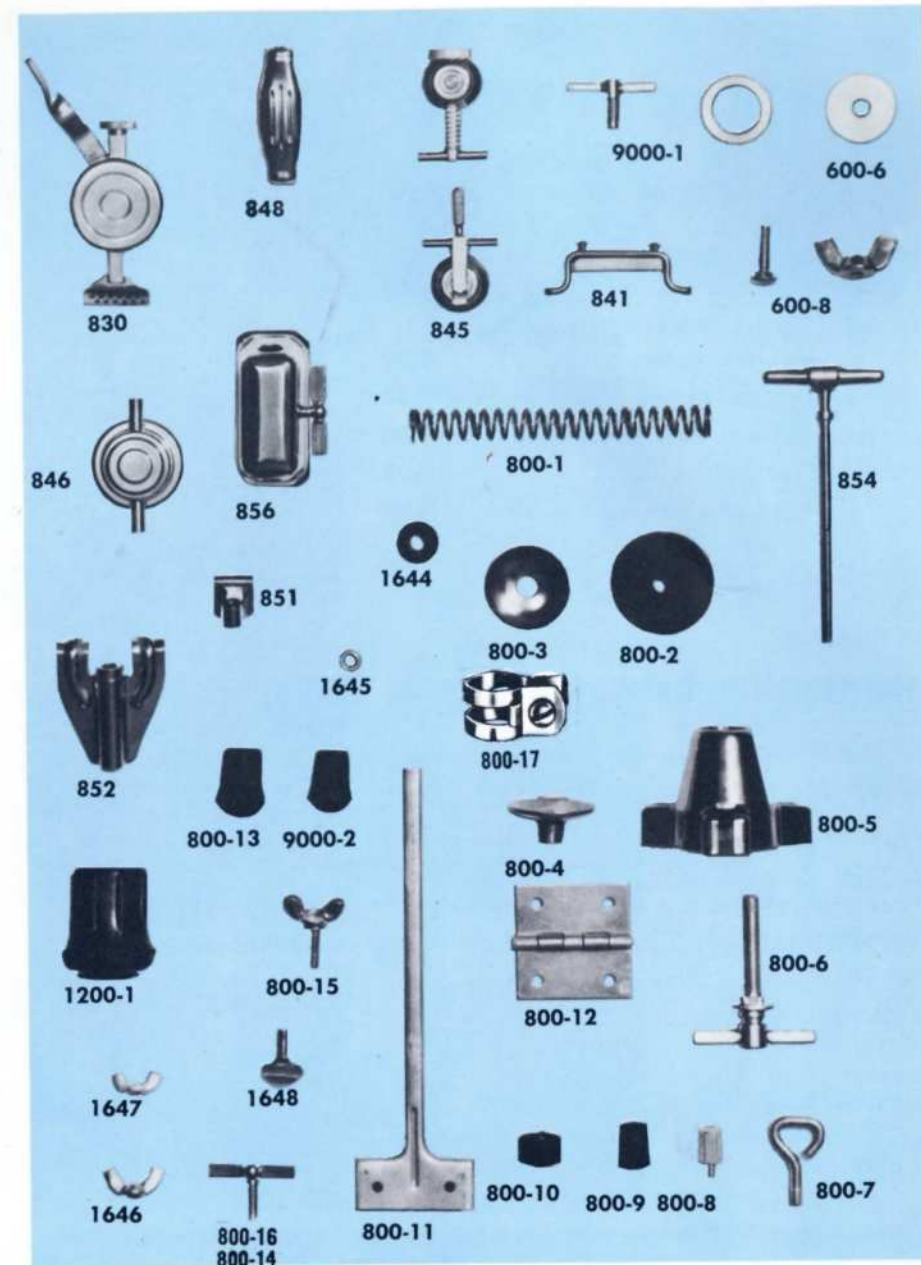

|                               |     |
|-------------------------------|-----|
| 600-8 Bolt and Large Wing Nut | .25 |
| 1646 ¼-20 Wing Nut            | .10 |
| 1647 10-24 Wing Nut           | .08 |
| 1648 ¼-20 Thumb Screw         | .12 |
| 1643 Rubber Cymbal Tube       | .06 |
| 1644 Leather Washer           | .10 |
| 1645 Tension Rod Washer       | .06 |
| 1649 10-24 Thumb Screw        | .10 |

#### COUNTER HOOPS

|                                   |        |
|-----------------------------------|--------|
| Chrome Triple Flange, Snare Side  | \$9.50 |
| Chrome Triple Flange, Batter Side | 9.00   |
| Wood Bass, Maple                  | 6.00   |
| Wood Bass, Lacquer                | 6.50   |
| Wood Bass, Pearl Inlaid           | 7.50   |
| Parade Hoop, Maple                | 3.00   |
| Parade Hoop, Lacquer              | 3.50   |
| Parade Hoop, Pearl Inlaid         | 4.50   |



## REPLACEMENT PARTS

### 1435 — TOM TOM HOLDER PARTS

- 1435-1 Rail Complete with washers, bolts and nuts.....\$6.00
- 1435-2 Small Clamp complete nut, bolt, and washer ..... 1.00
- 1435-3 Diamond plate with nuts and bolts 3.50
- 1435-4 Extension Rod, Long or Short.... 1.00
- 1435-5 Hex Key ..... 1.00
- 1435-6 Rail Clamp and Ratchet..... 5.00

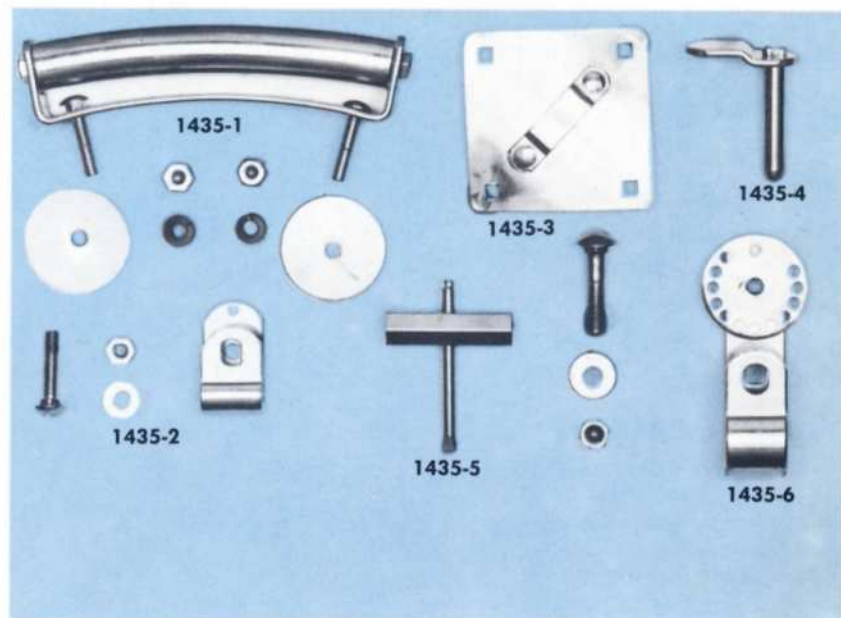

### SQUARE HEAD DRUM RODS

- 4150-1 1/2" .....\$ .40
- 4187-1 7/8" ..... .40
- 4250-2 1/2" ..... .40
- 4300-3" ..... .40
- 4350-3 1/2" ..... .50
- 4400-4" ..... .50
- 4450-4 1/2" ..... .50
- 4500-5" ..... .50



Chrome plated. All rod measurements are taken from under the collar to the end of the threads.

| Part No. | Description             | List Price | Part No. | Description                | List Price |
|----------|-------------------------|------------|----------|----------------------------|------------|
| 5000-F   | Footboard only          | \$4.00     | 403      | Spring                     | \$.22      |
| 5000-H   | Heel only               | 1.25       | 402      | Spring Screw               | .15        |
| 604      | Toe Clamp Pin           | .06        | 401      | Rocker                     | .30        |
| 603      | Toe Clamp Locking Screw | .40        | 400-A    | Rocker and Spring Assembly | .82        |
| 602      | Toe Clamp Casting       | .85        | 307      | Cam Side Bearing Nut       | .05        |
| 601      | Base Casting            | 6.00       | 305      | Rocker Hub                 | .20        |
| 507-2    | Heel Screws             | .06        | 302-2    | Bearing                    | .50        |
| 506-2    | Footboard Screws        | .06        | 300-A    | Hex Shaft Assembly         | 2.75       |
| 505      | Rivets (4/4) 2          | .03        | 203-2    | Cam Strap Screws           | .05        |
| 504      | Heel Clip               | .15        | 202      | Cam Strap                  | .45        |
| 503      | Flat Block              | .15        | 201      | Cam Casting                | 1.25       |
| 502-L    | Leather Hinge           | .30        | 103      | Hex Shaft Set Screw        | .35        |
| 502-M    | Metal Hinge             | .45        | 102      | Beater Shaft Set Screw     | .35        |
| 500-A    | Radius Rod Assembly     | 1.75       | 101      | Beater Hub Casting         | 1.25       |
| 404      | Spring Lock Nut         | .15        | 5000-C   | Complete Footboard         | 7.50       |
|          |                         |            | 202-N    | Nylon Strap                | .75        |

## Camco DRUM COVERINGS

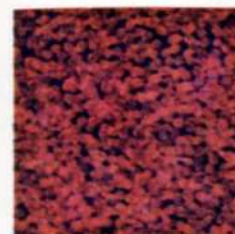

RED SPARKLE

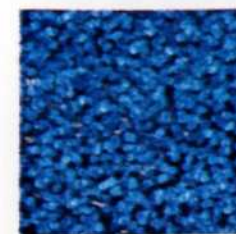

BLUE SPARKLE

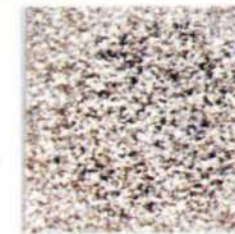

CHAMPAGNE SPARKLE

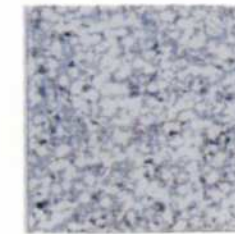

SILVER SPARKLE

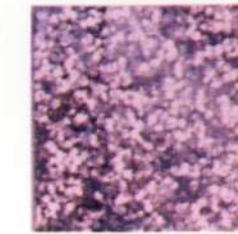

BURGUNDY SPARKLE



BLUE RIPPLE

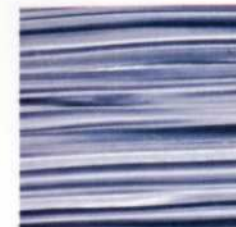

GRAY RIPPLE

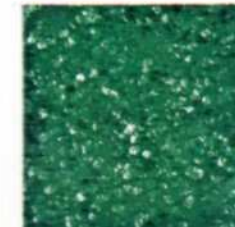

GREEN SPARKLE



GOLD SPARKLE

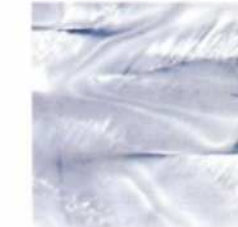

OYSTER



BLACK DIAMOND



WHITE PEARL



BLUE MOIRE



CHARCOAL MOIRE



AQUA MOIRE



CHROME MOIRE



GOLD MOIRE



PURPLE MOIRE



RED MOIRE



3-D MOIRE

## Camco Pedal Parts

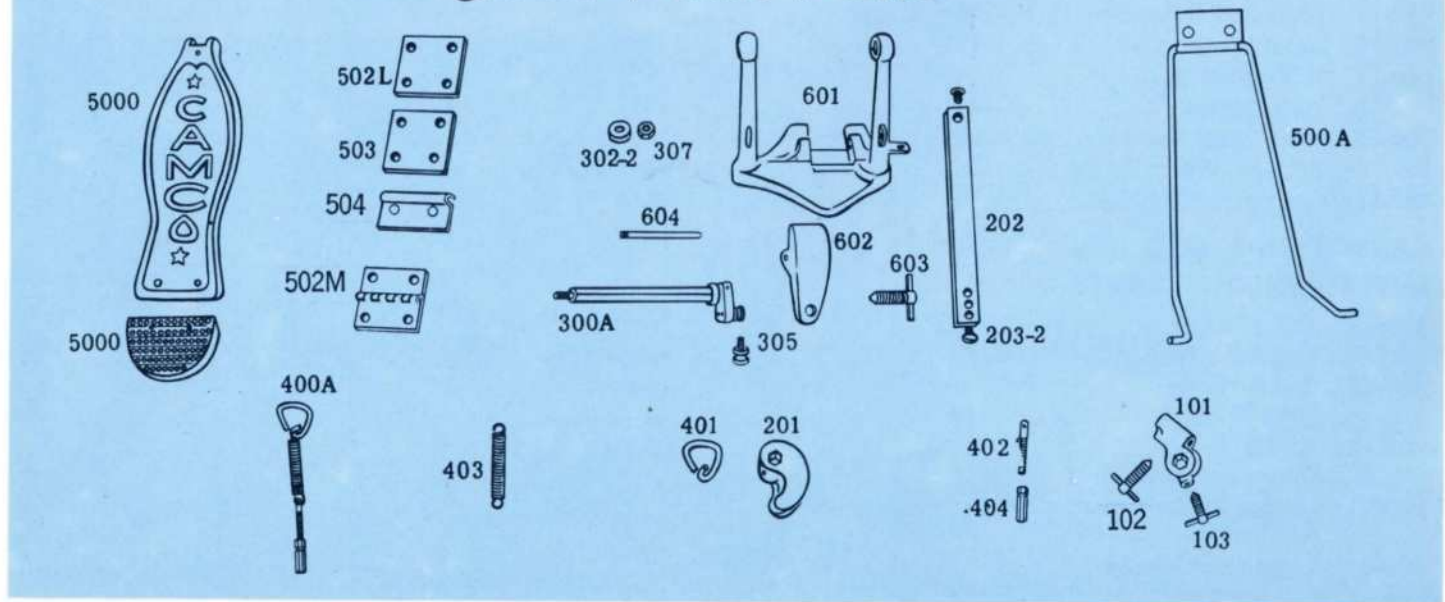

## INSTRUCTION BOOKS



A MODERN APPROACH TO INDEPENDENCE FOR THE ADVANCED DRUMMER

NICK CEROLI—\$4.00B

This book is designed to give drummer ability to play one rhythm against another.



DRUM METHOD No. 1  
\$2.50B

DRUM METHOD No. 2  
\$1.50B

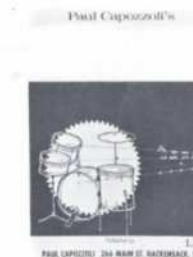

Percussion Ensemble  
Arranged by  
Sheldon Elias

\$3.00

Vol. 1 ..... \$2.00  
Vol. 2 ..... 2.00  
Vol. 3 ..... 2.00  
Vol. 4 ..... 2.00



JOEY CASS  
With Four Seasons



JOE DUKES  
Jack McDuff



FRED STOLL  
Roger Williams



RICK FRIGO  
Chicago



NORM JEFFRIES  
Hollywood Palace



STEVE RILLERA  
Righteous Brothers



SID BULKINS  
Las Vegas



MEL BROWNE  
"Temptations"



HAP GORMLEY  
New York



NICK CEROLI  
Tijuana Brass



EDDIE KNIGHT  
South Bend, Indiana



NORBY KING  
Chicago



KALIL MADI  
Big Tiny Little



TONY CASELLI  
Chicago



RICHARD MEISLER  
New York



PAUL HUMPHREY  
Hollywood



ALLEN LASCHOVER  
Santa Ana, California



JOAD PALMA  
Hollywood



MARSHALL THOMPSON  
Eddie Higgins



TONY DEE  
"NTH"  
Hollywood



DENNIS WILSON  
Beach Boy's