



LARRY B'EE
BROWN STUDIO - MUSICAL INSTRUMENTS
Tel. 786-5629
328 Rathbun Street
Providence, R. I. 02809

Kustom

Camco

THE ARISTOCRAT OF DRUMS



Camco

THE ARISTOCRAT OF DRUMS

The heartbeat and uniting force of group music is the cadenced expression of a quality drum ensemble. And whether it's a soft ruffle or a solid, rhythmic, thundering beat, you'll find quality with Camco.

A single sitting will convince the serious student and the accomplished professional they are playing truly fine musical instruments. Camco - no other name offers so much in the sound that holds a performance together.

INDEX

Bass Drums	11
Bass Drum Anchors	19
Bass Drum Mufflers	30
Bass Drum Rucks	27
Cases, Fibre	32
Casewares	21
Cong Ring	26
Covers	28
Covers	32
Cow Bells	21
Cow Bell Holders	17, 30
Cymbals	24
Finger Cymbals	24
Cymbal Crutches	16
Cymbal Floor Stands	18
Cymbal Holders, Band	25
Cymbal Holders, Bass Drum	17
Cymbal Holders, Snare	17
Cymbal Holders, Shell	17
Cymbal Holders, Wood	25
Cymbal Pads	25
Cymbal Straps	25
Cymbal Pouches	32
Cymbal Stands	25
Cymbal Tilters	15
Drum Eye	27
Drum Key	27
Drum Major Whistles	27
Drum Ours	3, 4, 5, 6
Drum Stands	18
Gongs and Stands	24
Graphic Cymbals	24
Guns	28
Heads, Plastic	26
Hi-Hat Stands	15
Illustrations	21
Instruction Books	31
Key Holders	27
Kits, Drum	8
Lamin Accessories	28
Lap Pans	27
Mallets	22, 23, 31
Morocos	21
Parade Drums	8, 12, 13
Pedals	14
Pedal Resters	19
Practice Pad	21, 26
Practice Pad Stands	21
Practice Pad Sets	26
Replacement Parts	23, 34
Shap Sticks	29
Shigh Bells	29
Sings, Bell Lyra	31
Sings, Drum	27
Snare Drums	7, 8, 9
Snare	30
Snare Drum Muffler	30
Snare Strainers	33
Song Whistles	29
Spurs	19
Square Head Rock	34
Sticks, Bass Drum	22, 23, 27
Sticks, Snare Drum	20, 23
Sticks, Tenor	23
Sticks, Tom-Tom	22
Tambourines	29
Thrones	16
Tom-Toms	10
Tom-Tom Holders	18
Tom-Tom Legs	10
Tone Controls	30
Triangles	30
Triangle Holders	30
Whistles	27, 29
Wire Brushes	21
Wood Blocks	21
Wood Block Holders	30
Wood Rattle	29
Wood Whistles	29

TERMS

All prices are suggested retail, subject to change without notice. F.O.B. shipping point.

Substitution permissible. Colors matched on non-cancellable, non-returnable basis. All metal parts chrome plated. Heads and Cymbals not guaranteed.

Plastic heads standard on all drums unless otherwise specified. Calf Skin Heads priced extra.

Claims on losses, damages, or pilferage must be made to the Transportation Company. Our responsibility ceases upon delivery to the Transportation Company. Shipments should be opened and examined immediately for loss or damage, either **VISIBLE** or **CONCEALED**.

Check all contents and save all cartons packing material. Call your local agent at once for an inspection. Obtain a signed inspection report from him and file claim for loss or damage.

"TRIPLE TOM-TOM" OUTFIT

1	450	Aristocrat 5 x 14 Snare Drum	\$ 80.00
1	1122	Aristocrat 14 x 22 Bass Drum	140.00
1	1412	Aristocrat 8 x 12 Tom-Tom	75.00
1	1413	Aristocrat 9 x 13 Tom-Tom	80.00
1	1410	Aristocrat 10 x 14 Tom-Tom	84.00
1	1416	Aristocrat 16 x 16 Tom-Tom	100.00
1 pr.	1480	Arch Disappearing Spurs	8.50
1	13	Triple Tom-Tom Holder	40.00
1 set	4412	Tom-Tom Legs	12.00
1	5000	Deluxe Foot Pedal	27.50
1	500	Direct Pull Hi-Hat Stand - Tripod Legs	39.50
2	710	Cymbal Stands	40.00
1	650	Buck Rogers Drum Stand - Tripod Legs	17.50
1 pr.	1070	Wire Brushes, Rubber Covered Handles, Loop End	1.75
1	1430	Felt Muffler Strips	1.00
1 pr.		Drum Sticks	1.60
		Total Value in Choice of Pearl Finishes	758.35
		SPECIAL PRICE - Pearl Finishes	720.00
		Not Lacquer or Stain	656.00
		Included Moire Finishes	757.00

DRUMS SHOWN IN BLUE RIPPLE



Camco DRUM COMPANY

A SUBSIDIARY OF KUSTOM ELECTRONICS

1010 WEST CHESTNUT, CHANUTE, KANSAS-TELEPHONE 316-431-4380

Camco

"BIG BAND" OUTFIT

- Double Flange Counter Hoops

- 6-Ply Electronically Bonded Shells

- All Metal Parts AAA Chrome Plated

1	450	Aristocrat 5 x 14 Snare Drum	\$ 90.00
2	1120	Aristocrat 14 x 20 Bass Drums	270.00
2	1412	Aristocrat 8 x 12 Tom-Tom	150.00
1	1414	Aristocrat 14 x 14 Tom-Tom	90.00
2 pr	1480	Arch Disappearing Spurs	17.00
1	19	Double Swivel Tom-Tom Holder on a stand	35.00
1 set	4410	Tom-Tom Legs	10.00
2	5000	Deluxe Foot Pedals	55.00
1	900	Direct Pull Hi-Hat Stand—Flush Legs	39.50
2	700	Cymbal Stands	28.00
1	850	Buck Rogers Drum Stand—Flush Legs	17.50
1 pr	1070	Wire Brushes, Rubber Covered Handles, Loop End	1.75
2	1430	Felt Muffler Strips	2.00
1 pr		Drum Sticks	1.60
		Total Value in choice of Pearl Finishes	807.35
		Special Price:	
		Pearl Finishes	767.00
		Lacquer or Stain Finishes	694.00
		Moire Finishes	807.00

Cymbals Not Included

DRUMS SHOWN IN 3-D MOIRE



Camco

"DOUBLE TOM-TOM" OUTFIT

with "ARISTOCRAT" Drums

- Double Flange Counter Hoops

- 6-Ply Electronically Bonded Shells

- All Metal Parts AAA Chrome Plated

1	450	Aristocrat 5 x 14 Snare Drum	\$ 90.00
1	1122	Aristocrat 14 x 22 Bass Drum	140.00
2	1412	Aristocrat 8 x 12 Tom-Toms	150.00
1	1416	Aristocrat 16 x 16 Tom-Tom	100.00
1 pr	1480	Arch Disappearing Spurs	8.50
1	5000	Deluxe Foot Pedal	27.50
1	650	Buck Rogers Drum Stand—Tripod Legs	17.50
1	500	Direct Pull Hi-Hat Stand—Tripod Legs	39.50
1	18	Double Swivel Tom-Tom Holder	27.50
2	700	Cymbal Stands	28.00
1 set	4410	Tom-Tom Legs	10.00
1 pr	1070	Wire Brushes, Rubber Covered Handles, Loop End	1.75
1	1430	Felt Muffler Strip	1.00
1 pr		Drum Sticks	1.60
		Total Value in choice of Pearl Finishes	\$642.85
		Special Price:	
		Pearl Finishes	\$611.00
		Lacquer or Stain Finishes	557.00
		Moire Finishes	642.00

Cymbals Not Included

Here is the "Big Apple" of all drum outfits... designed for the drummer who is seeking the complete range of sounds—with true drum character in every beat—and with a full measure of modern styling and mechanical perfection. This set is for both large and small bands. It is right for the classics or for jazz. There is nothing finer to be had and nothing that will give greater playing satisfaction and eye appeal than the advanced Double Tom-Tom Outfit.

DRUMS SHOWN IN BLUE MOIRE



1	450	Aristocrat 5 x 14 Snare Drum	\$ 90.00
1	1120	Aristocrat 14 x 20 Bass Drum	135.00
1	1412	Aristocrat 8 x 12 Tom-Tom	75.00
1	1414	Aristocrat 14 x 14 Tom-Tom	90.00
1 pr	1480	Arch Disappearing Spurs	8.50
1	15	Single Swivel Tom-Tom Holder	20.00
1 set	4410	Tom-Tom Legs	10.00
1	1450	Shell Mount Cymbal Holder	8.50
1	5000	Deluxe Foot Pedal	27.50
1	500	Direct Pull Hi-Hat Stand—Tripod Legs	39.50
1	650	Buck Rogers Drum Stand—Tripod Legs	17.50
1	1103	Cow Bell	3.00
1	1422	Cow Bell Holder	3.00
1 pr	1070	Wire Brushes, Rubber Covered Handles, Loop End	1.75
1	1430	Felt Muffler Strip	1.00
1 pr		Drum Sticks	1.60
		Total Value in choice of Pearl Finishes	\$531.85
		Special Price:	
		Pearl Finishes	505.00
		Lacquer or Stain Finishes	456.00
		Moire Finishes	530.00

Cymbals
Not
Included

Camco

ASTRO

OUTFIT



- Double Flange Counter Hoops

- 6-Ply Electronically Bonded Shells

- All Metal Parts
AAA Chrome Plated

DRUMS SHOWN IN BURGUNDY SPARKLE



DRUMS SHOWN IN WALNUT STAIN

Camco SWINGER OUTFIT

1	450	Aristocrat 5 x 14 Snare Drum	\$90.00
1	1120	Aristocrat 14 x 20 Bass Drum	135.00
1	1412	Aristocrat 8 x 12 Tom-Tom	75.00
1 pr	1480	Arch Disappearing Spurs	8.50
1	1435C	Chrome Consolette Tom-Tom Holder	13.50
1	1450	Shell Mount Cymbal Holder	8.50
1	5000	Deluxe Foot Pedal	27.50
1	800	Hi-Hat Stand—Flush Base	24.00
1	600	Drum Stand—Flush Base	15.00
1 pr	1070	Wire Brushes, Rubber Covered Handles, Loop End	1.75
1	1430	Felt Muffler Strip	1.00
1 pr		Drum Sticks	1.60
		Total Value in choice of Pearl Finishes	401.35
		Special Price:	
Cymbals Not Included		Pearl Finishes	381.00
		Lacquer or Stain Finishes	348.00
		Moire Finishes	399.00

Camco

TUXEDO OUTFIT

1	701	Tuxedo 5 x 14 Snare Drum	\$ 79.50
1	2330	Tuxedo 14 x 20 Bass Drum	125.00
1	3012	Tuxedo 8 x 12 Tom-Tom	65.00
1 pr	1480	Arch Disappearing Spurs	8.50
1	1450	Shell Mount Cymbal Holder	8.50
1	1435C	Chrome Consolette Tom-Tom Holder	13.50
1	600	Drum Stand—Flush Base	15.00
1	800	Hi-Hat Stand—Flush Base	24.00
1	5000	Deluxe Foot Pedal	27.50
1 pr	1070	Wire Brushes, Rubber Covered Handles, Loop End	1.75
1	1430	Felt Muffler Strip	1.00
1 pr		Drum Sticks	1.60
		Total Value choice of Pearl Finishes	370.85
		Special Price:	
Cymbals Not Included		Pearl Finishes	352.00
		Lacquer or Stain Finishes	318.00
		Moire Finishes	370.00



DRUMS SHOWN IN CHAMPAGNE SPARKLE

Camco NO. 99 SUPER



NEW PARALLEL STRAINER

\$119.00

5x14
In Metal or
Choice of Pearls



FEATURES . . .

- Snare Contacts Head Even
- Choke Free Sound
- 16 Strand Snares
- Polished Chrome Shell
- Triple Flange Hoops
- Internal Tone Control
- Camco Key Holder and Key

TUXEDO METAL DRUM

- TRIPLE FLANGE HOOPS
- 20 STRAND SNARE
- CHROME SHELL
- TONE CONTROL
- KEY HOLDER AND KEY
- 8 LUGS



No. 701-M 5x14 Snare Drum \$98.00

99-M Super—Chrome Shell \$119.00

99-P Super—Choice of Pearl \$119.00

THE "ARISTOCRAT"

A great number of top ranking professionals declare the 5 x 14 size drum to be the best for those who do all-around work with different groups. The "ARISTOCRAT" 5 x 14 has both delicacy and volume and will withstand hard usage on the road. It is a "tailor-made" instrument of mechanical efficiency and modern styling . . . A wonderful easy-playing drum, with sounds that will please the perfectionist.

ORCHESTRA

450-P 5x14 Choice of Pearls	\$90.00
450-L 5x14 Choice of Lacquers	82.00

CONCERT ARISTOCRAT

452-P 6½x14 Choice of Pearls	\$92.00
452-L 6½x14 Choice of Lacquers	84.00

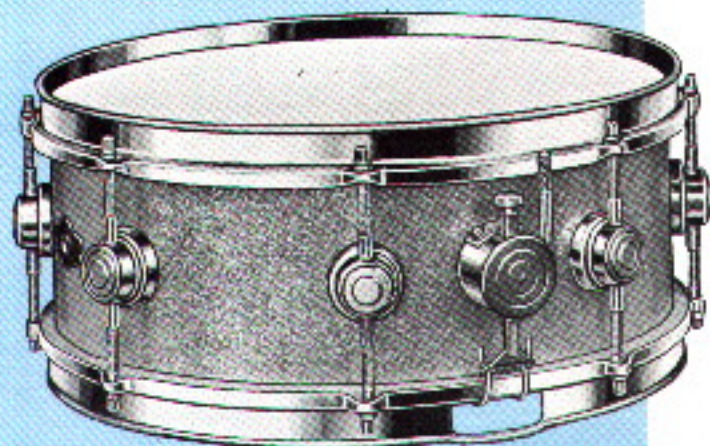

Tone Control

Choice of Calf or Plastic Heads
Photo Shows 5 x 14 in Sparkling Gold

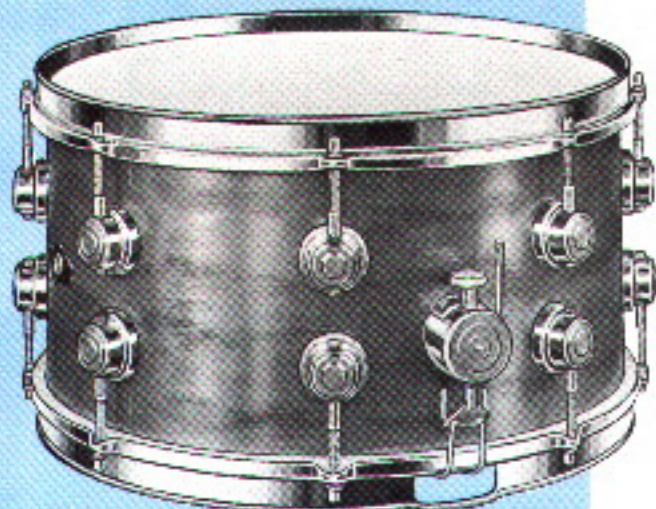

Tone Control

All Metal Parts on All Drums Are
AAA Chrome Plated
Photo Shows 8 x 15 in Mahogany

THE BAND "ARISTOCRAT"

This is a real "drummer's drum," with colorful, rich and penetrating sounds that make it the very "tops" for large concert bands and orchestras. It is the correct size for producing great volume; yet it is so sensitive that it can be played down to a "whisper." Like all "ARISTOCRATS," it is very carefully made in every part—even to finishing the inside of the shell.

456-P 8x15 Choice of Pearls	\$95.00
456-L 8x15 Choice of Lacquers	87.00

Gut Snares—\$2.00 Extra

**ALL METAL PARTS
TRIPLE CHROME
PLATED**

STUDIO MODEL

701-EL 5x14 Lacquer or Mahogany ..	\$55.00
701-EP In Pearl	65.00

8 Lug
Triple Flange Hoops



THE 'ORCHESTRA' TUXEDO

5x14 Snare Drum
Drum Shown in Blue Maire

- 701-P In Pearls \$79.50
701-L In Lacquers 69.50
712-P 6½x14 Choice of Pearls.... \$81.50
712-L 6½x14 Choice of Lacquers .. 71.50

Tone Control and Key Holder and Key Included
8 Streamline Lugs

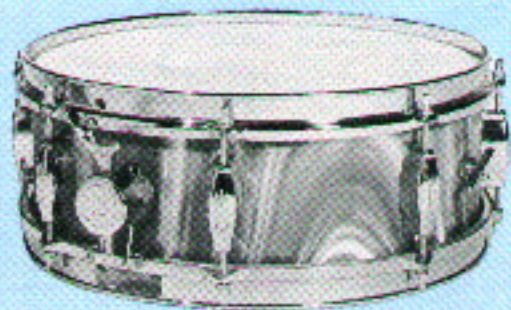

No. 910-D DELUXE DRUM KIT

- 701-EP 5x14 Pearl Snare Drum .. \$65.00
Blue Student Case 21.00
1100 Round Practice Pad 3.00
1716-C Chrome Drum Stand 10.50
1 pair 2-B Drum Sticks .. 1.60

TOTAL VALUE: \$101.10
SPECIAL PRICE: 96.00



10" x 14" PARADE DRUM

- 515-L In Lacquer
or Mahogany \$65.00
515-P In Pearl \$75.00
Sticks, and Sling
Choice of Wood or Metal
hoop. 8 Rod.

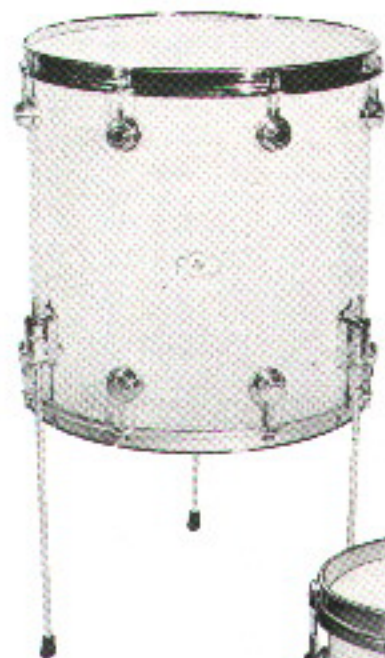

Photo Shows
16x16 in
3D Moire
and 4410
Tom-Tom Legs



Photo Shows
9x13 in
White Pearl

"ARISTOCRAT" TOM-TOMS

All "ARISTOCRAT" Tom-Toms have our exclusive Double Edge-Double Flange Hoops and "turret" casings with self-aligning rods. All shells are 4-Ply electronically bonded, with reinforcing hoops. Shells are finished on the inside to prevent moisture penetration. Tone Control included.

		Stain or Lacquer	Pearl
1412	8x12	\$ 68.00	\$ 75.00
1413	9x13	72.00	80.00
1410	10x14	74.00	84.00
1415	12x15	75.00	84.00
1414	14x14	75.00	90.00
1416	16x16	85.00	100.00
1418	16x18	108.00	124.00
1420	18x20	124.00	144.00

CAMCO TOM-TOM LEGS

There are 12 ring notches turned into each of the chrome plated legs. Wing screws seat themselves into the notches. Legs cannot slip.

4410	3 Legs and Brackets.....	\$10.00
4411	1 Leg and Bracket.....	3.35

"TUXEDO" TOM-TOMS

		Stain or Lacquer	Pearl
3012	8x12	\$ 59.00	\$ 65.00
3013	9x13	62.00	67.50
3014	14x14	68.00	80.00
3016	16x16	72.00	85.00

CAMCO WIDE SPREAD TOM-TOM LEGS

The fine notches turned into the legs provide ample height adjustment and positively prevent slipping under heavy beating. Note that legs flare outward.

4412	3 Legs and Brackets.....	\$12.00
4413	1 Leg and Bracket.....	4.00



Photo Shows
14x14 in
Blue Moire
and 4412
Wide Spread Legs

Camco

"ARISTOCRAT" BASS DRUMS

Drummers and leaders in both the school and professional fields must have the particular "sound style" that blends in with the musical character of their special organization. Jobbing drummers often have to alter the sounds for different groups. We are, therefore, building our bass drums to withstand the necessary adjustments. They have 6-Ply electronically bonded shells, with reinforcing hoops. The steel double claw hooks are of thicker gauge and have a wider bearing surface than those on most drums. The finishes are top grade, including hand-rubbed lacquers. These are indeed rugged, beautiful drums that can be adjusted to sounds required on any job.

		Stain or Lacquer	Pearl
1118	14x18	\$110.00	\$130.00
1120	14x20	115.00	135.00
1122	14x22	120.00	140.00
1124	14x24*	130.00	153.00

*14x24 has 10-Lugs

"TUXEDO" BASS DRUMS

		Stain or Lacquer	Pearl
2328	14x18	\$100.00	\$120.00
2330	14x20	105.00	125.00
2332	14x22	110.00	130.00
2334	14x24	115.00	140.00



Photo Shows 14x22 in White Pearl



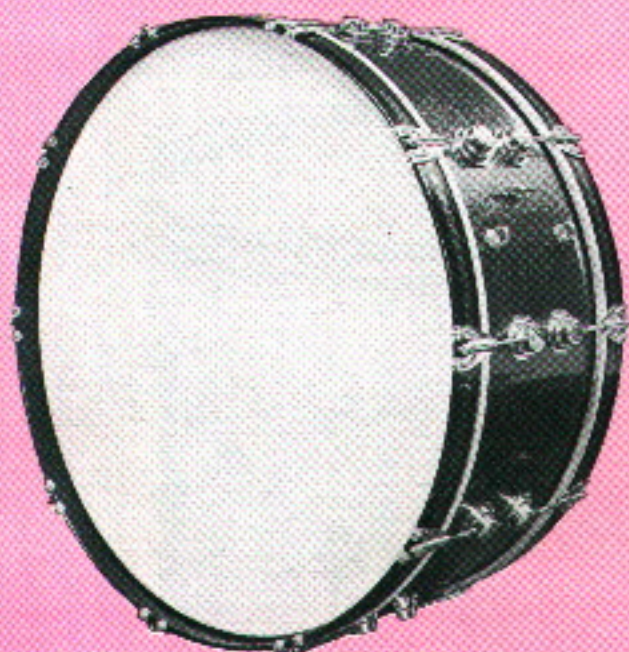

Camco "PARADE MASTERS"

- CHROME
- DELUXE STRAINER
- 4-PLY SHELLS
- INTERNAL TONE CONTROL
- SNAP IN KEY HOLDER
- SEPARATE TENSION

PARADE MASTER SNARE DRUM Complete with Drum Sticks and Slings

		Lacquer	Pearl
458	10x14	\$ 80.00	\$ 93.00
460	12x15	93.50	107.00
462	12x16	95.00	108.00

PARADE MASTER TENOR DRUMS Complete with Beaters and Slings

		Lacquer	Pearl
464	10x14	\$ 80.00	\$ 93.00
466	12x15	93.50	107.00
468	12x16	95.00	108.00

PARADE MASTER SCOTCH BASS DRUMS Complete with Slings and Beaters

		Lacquer	Pearl
1145	8x24	\$123.00	\$145.00
1146	10x24	123.00	145.00
1147	8x28	133.00	155.00
1148	10x28	133.00	155.00

Moire Covering Extra



Long Island Sourisiers

*For inlaid hoops on lacquer drums add \$5.00
Plastic heads furnished unless other specified
Gut Snares \$2.00 Extra*

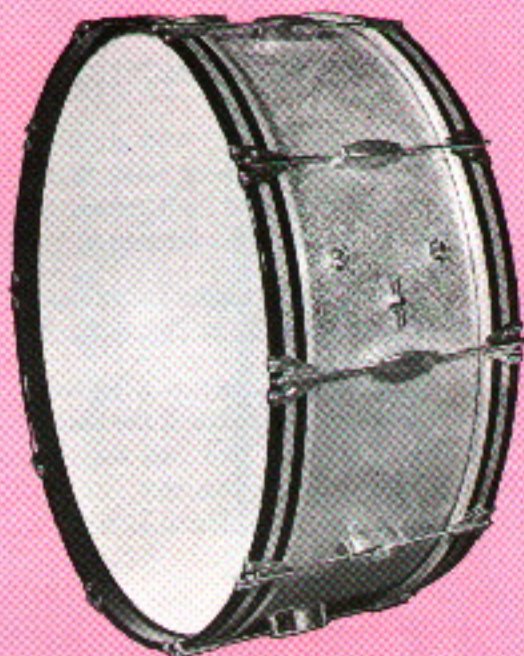

Camco "PARADE QUEEN"

- CHROME
- 4-PLY SHELLS
- SNAP-IN KEY HOLDER
- STREAMLINE CASINGS
- SEPARATE TENSION
- INTERNAL TONE CONTROL

SNARE DRUMS

complete with Sticks and Sling

713-L	10x14	Lacquer or Mahogany	\$ 69.00
713-P	10x14	Choice of Pearl	82.50
716-L	12x15	Lacquer or Mahogany	84.00
716-P	12x15	Choice of Pearl	94.00
718-L	12x16	Lacquer or Mahogany	88.50
718-P	12x16	Choice of Pearl	99.00

TENOR DRUMS

complete with Tenor Sticks and Sling

720-L	10x14	Lacquer or Mahogany	\$ 69.00
720-P	10x14	Choice of Pearl	82.50
722-L	12x15	Lacquer or Mahogany	84.00
722-P	12x15	Choice of Pearl	94.00
724-L	12x16	Lacquer or Mahogany	88.50
724-P	12x16	Choice of Pearl	99.00

SCOTCH BASS DRUMS

complete with Slings and Beaters

3018-L	8x24	Lacquer or Mahogany	\$118.00
3018-P	8x24	Choice of Pearl	140.00
3020-L	10x24	Lacquer or Mahogany	118.00
3020-P	10x24	Choice of Pearl	140.00
3022-L	8x28	Lacquer or Mahogany	128.00
3022-P	8x28	Choice of Pearl	150.00
3024-L	10x28	Lacquer or Mahogany	128.00
3024-P	10x28	Choice of Pearl	150.00

Moire Covering Extra



*St. Joseph Military Academy
La Grange, Ill.*

CAMCO DELUXE PEDAL

**"THE PEDAL OF
PEERLESS PERFORMANCE"**

The vast number of "Big Names" who are using the Camco Deluxe Pedal is definite proof that it has stood the test of time and fully meets the exacting demands of the Modern Drummer.

Its mechanical perfection plus rugged construction are two of the chief reasons for its popularity.

Simplicity of adjustments eliminates guess-work and permits the Drummer to arrive at the desired feel, balance and flow; and with just the right amount of resistance that suits him best . . . This assures smooth, easy and fast action at all tempos.

Positively frictionless and quiet.

Here is the pedal that does not divert the mind, allowing the Drummer to put more emphasis on stick technique.

5000 Split Footboard

\$27.50

5000-S One Piece Footboard

\$27.50

Ball Bearings

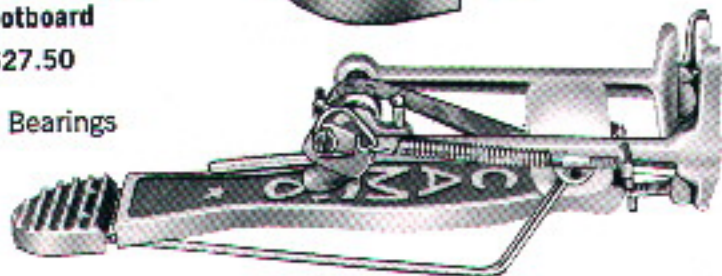
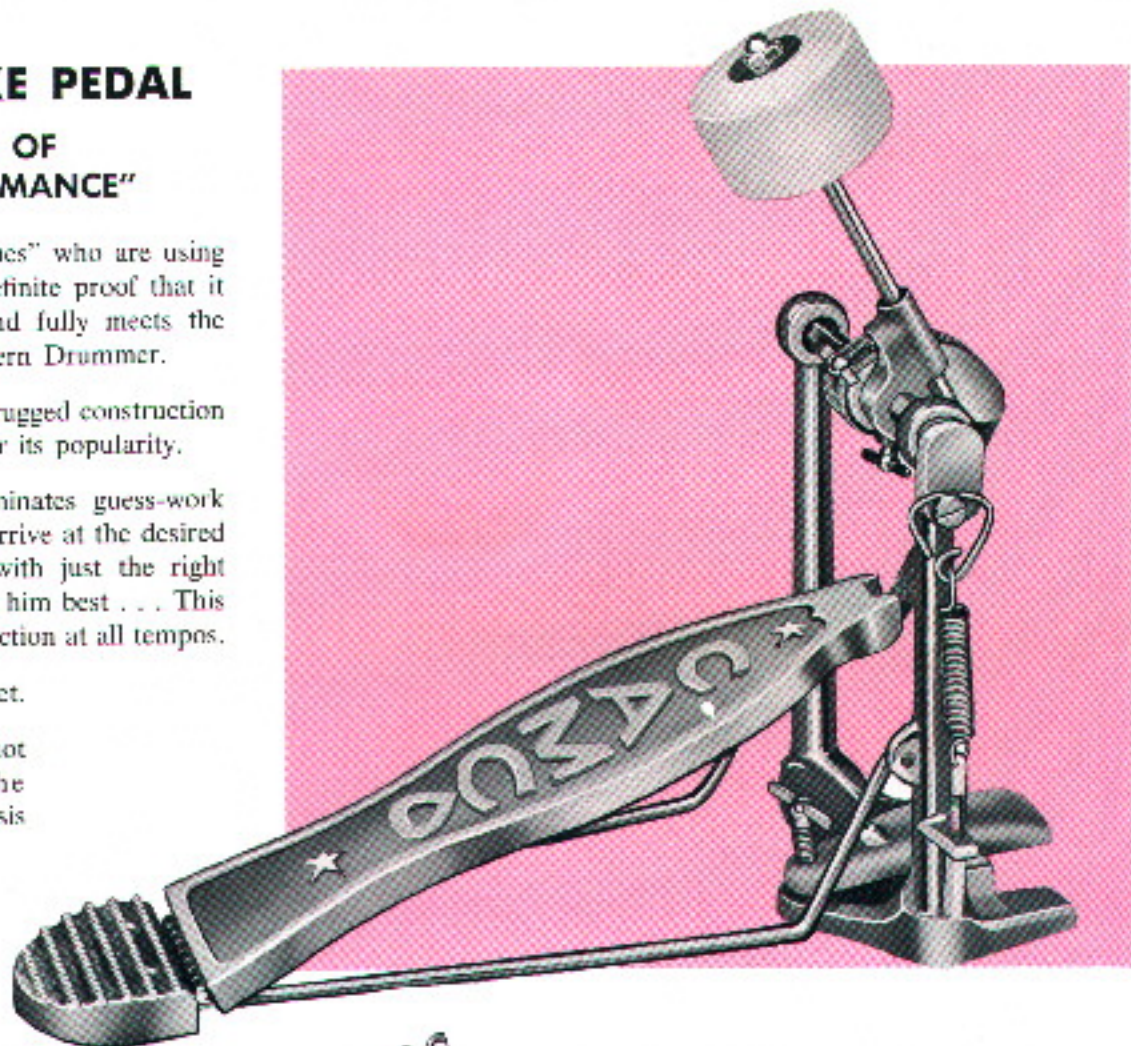

Polished aluminum and chromium-plated parts . . . equipped with solid felt beater ball unless otherwise specified . . . weighs only 3½ lbs. . . . folds easily and compactly without removing any parts whatever.

CAMCO STANDARD PEDAL

"Exceptional Efficiency in a Lower-Priced Model"

Polished aluminum and baked enamel parts . . . equipped with cork beater ball . . . weighs 3½ lbs. . . . folds compactly without removing any parts.

6000 \$21.00

Ball Bearings

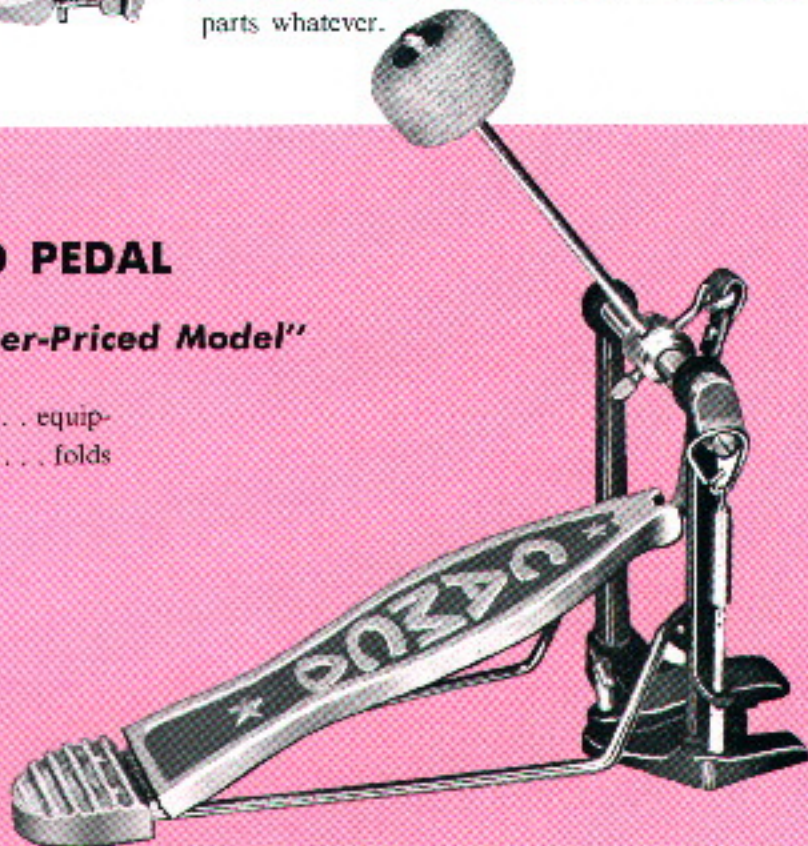

NEW CAMCO DIRECT PULL HI-HATS

Newest improved Hi Hat on the market in both tripod and flush base. All features shown by arrows are included in both Hi Hats.

500 HI-HAT
split footboard
\$39.50

500-S HI-HAT
One Piece Footboard
\$39.50

900 HI-HAT
split footboard
\$39.50

900-S HI-HAT
One Piece Footboard
\$39.50

NEW IMPROVED CLUTCH
CYMBAL TILTING ADJUSTMENT
KNURL KNOB FOR SPRING ADJUSTMENT THAT CAN BE CHANGED AT WILL
LOCK SCREW FOR SPRING ADJUSTMENT KNOB
TWO HEAVY SPURS PREVENTS CREEPING

All Chrome Plated.

THE FAMOUS "CAMCO" DELUXE HI-HAT

All of the desired qualities in Hi-Hat mechanism and playing ease are positively to be found in this exceptional model. The drummer can be so sure of "no bugs" that he can devote his full attention to cymbal sounds. Floor flush steel legs. Will not creep. Height adjusting.

800 Chrome Only \$24.00

Cymbal not included

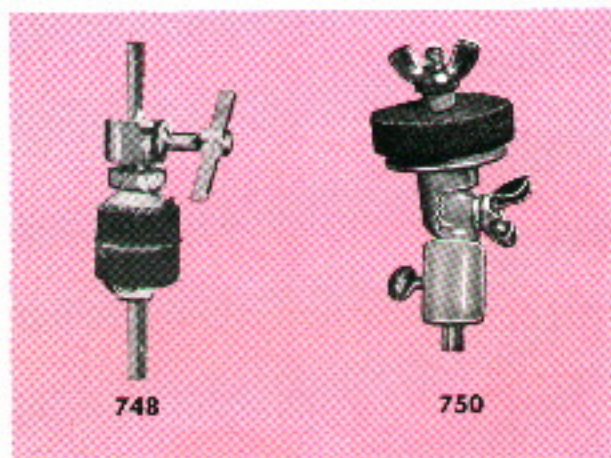

CAMCO HI-HAT CLUTCH
Simple and efficient.

748 \$2.40

CAMCO TILTER
Precision die cast, can't slip ratchet.

750 Chrome \$2.40
751 Nickel \$2.00

WALBERG REGULAR HI-HAT

502N Nickel \$15.00
502C Chrome \$18.00

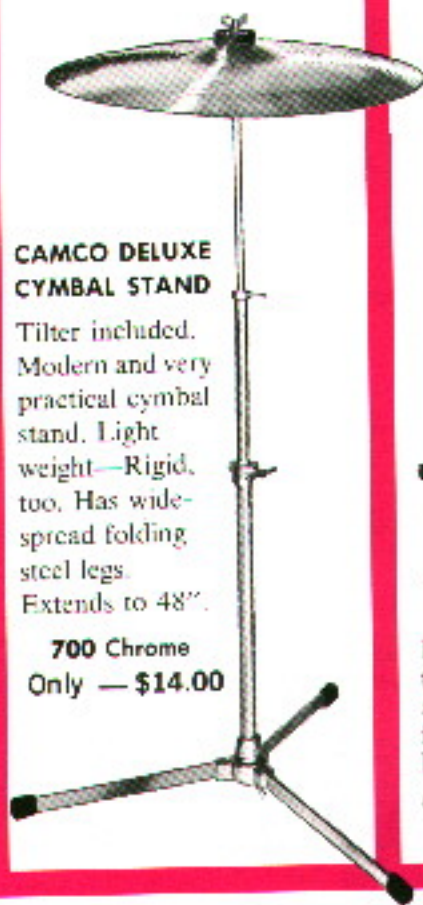

**CAMCO DELUXE
CYMBAL STAND**

Tilter included. Modern and very practical cymbal stand. Light weight—Rigid, too. Has wide-spread folding steel legs. Extends to 48".

700 Chrome Only — \$14.00



**"CAMCO" FLUSH BASE
DRUM STAND**

Folding legs open flush to floor. Ratchet angle adjustment. Extendable for standing position. A high quality stand.

600 Chrome Only . . \$15.00

**BUCK ROGERS
DRUM STAND
FLUSH BASE**



850 \$17.50

**BUCK ROGERS
DRUM STAND
TRIPOD BASE**



650 \$17.50



CAMCO THRONE

Chrome Only. A steel screw through steel collar eliminates all possibilities of slipping.

Back rest \$2.25 extra.

9000 \$21.00



WALBERG THRONE

An old reliable rigid model — Padded seat. Back rest \$2.25 extra.

865-N Nickel . . . \$17.50

**NO. 710
HEAVY EXTRA HIGH
CYMBAL STAND**

Raises to 58" High
Has New Swivel Tilter

\$20.00



CYMBAL HOLDERS

COW BELL HOLDERS

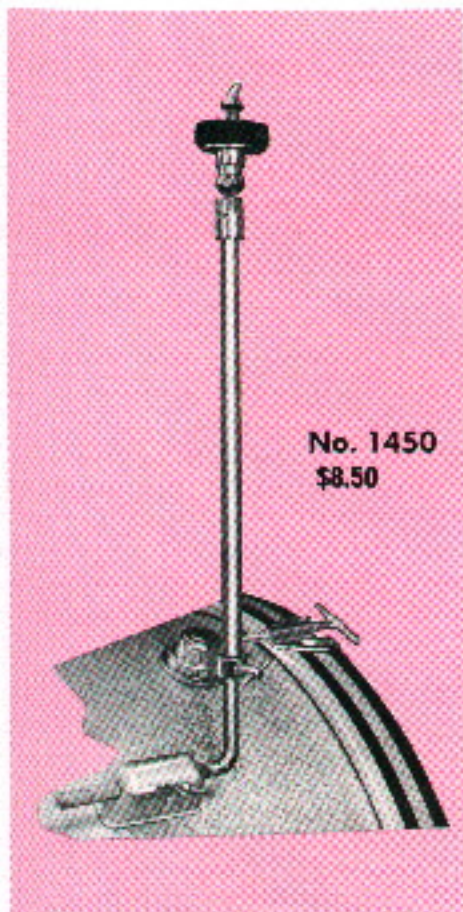

No. 1450
\$8.50



Tilters
included

Disappearing shell
mount cymbal
holder. Chrome.
No. 1440 . . . \$5.00

Height adjusting
telescope cymbal
sleeve.
Chrome Only.
No. 1445 \$5.00



NO. 755
**NEW SWIVEL
TILTER**

\$4.50

CAMCO PEDAL PRACTICE PAD

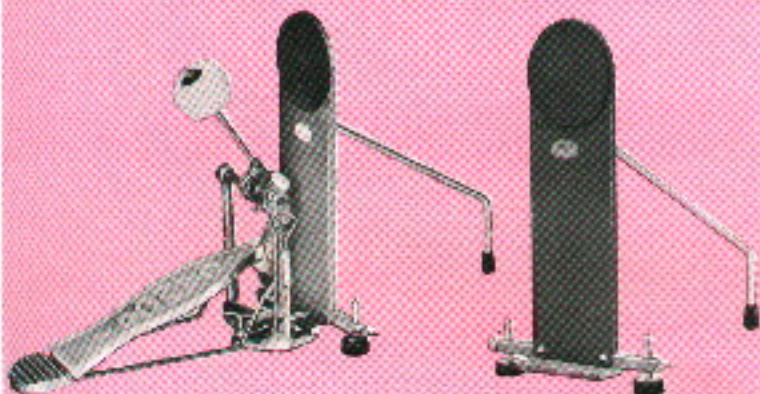

The importance of "foot work" in modern drumming equals that of stick technique. This practical pedal practice pad is the most advanced design made. It is well made of aluminum and steel parts, with a rubber disc beating surface. Takes up very little space. It will definitely improve "the beat."

1000 \$8.50



BRUSH CYMBAL HOLDER

A new high post model. Cymbal is placed higher for less reaching and it has the extra strong "Camco" hoop clamp.
1428- Chromium AAA \$2.90

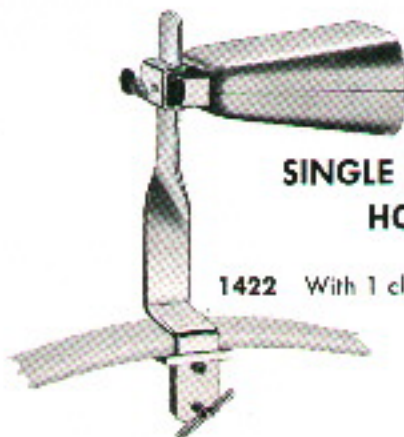

SINGLE COW BELL HOLDER

1422 With 1 clamp \$3.00

TOM-TOM HOLDERS

CAMCO

NEW MODERN SWIVEL TOM - TOM HOLDERS

Made From All Machine Parts
No Castings to Break
Chrome Plated

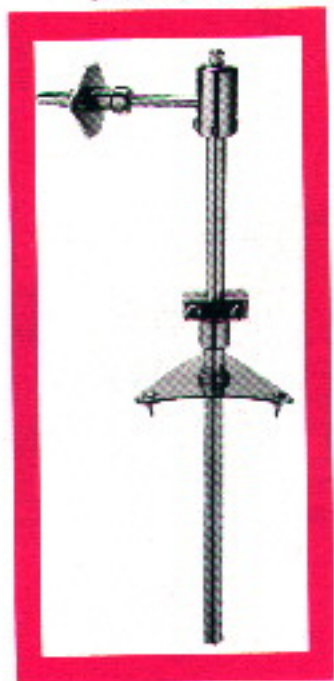

15 Single Swivel Tom-Tom Holder \$20.00

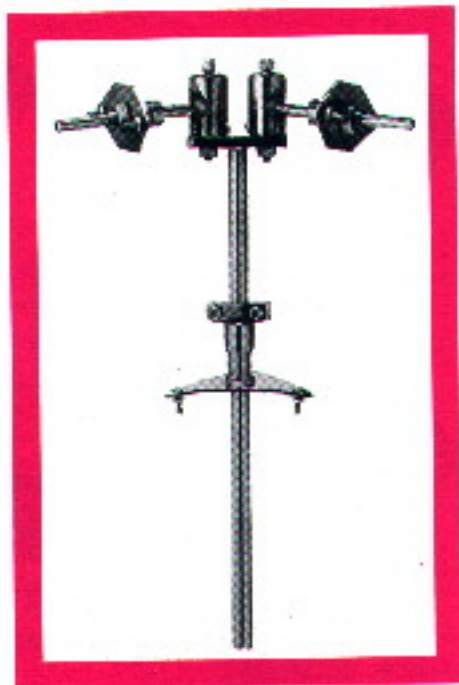

18 Double Swivel Tom-Tom Holder \$27.50

13 Triple Swivel Tom-Tom Holder \$40.00

19 Double Swivel Tom-Tom Holder
Mounted on Stand \$35.00

THE CONSOLETTTE TOM-TOM HOLDER



A popular model which has full adjustments. Well made and very strong.

1435-C	Chrome	\$13.50
1435-N	Nickel	\$10.50
1435-CD	Chrome Double Tom-Tom Holder	\$20.00

DOUBLE TOM-TOM HOLDER



14 Double Tom-Tom Holder \$20.00

16 Double Tom-Tom
Holder on Stand \$24.00

DISAPPEARING SPURS

Shell Mount, rubber tips included. The square rods are arched and point straight to the floor. They slide in a square notch in the round housing - cannot turn. More floor spread than others. Made of all strong machine parts to stand heavy wear and to last. Can be mounted straight to the floor or can be mounted to tilt forward.

1480 Pair, Chrome \$8.50

DISAPPEARING SPURS

Shell Mount, round steel rods slide in and out of bass drum shell. Can be used with either rubber or pointed tip.

1705 Pair, Chrome \$5.00

REGULATION SPURS

Hoop Mount. Equipped with 3 1/2" spikes. Often used as extras for additional assurance against creeping on uneven floors.

1542 Pair, Nickel Only \$1.40

BASS DRUM ANCHOR

Hoop Mount. Hoop clamp with two reversible spurs. Can use either steel points or rubber tips.

1601 Chrome \$6.00

1602 Nickel \$5.00

STICK-FAST SPUR ANCHORS

For all Model Spurs. Spurs fit into rubber cone bases. The sponge rubber floor grips will not creep.

1544 Pair \$4.90



1480

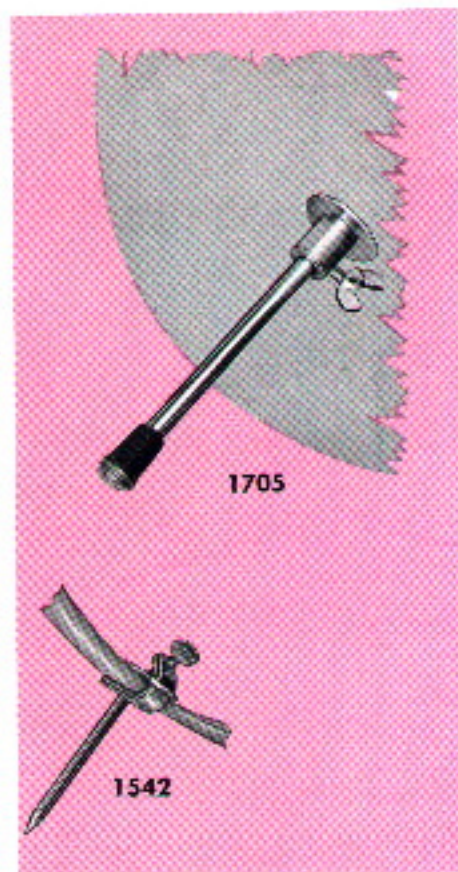

1705

1542

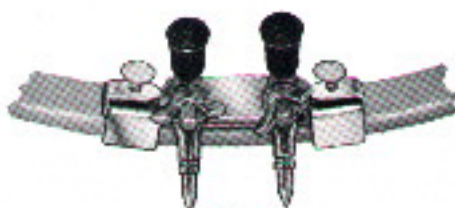

1601

1602



1544



SOLID CORK
Solid sound
All-around work
250 - \$2.00



LAMB'S WOOL
Soft boom sound
Concert work
251 - \$3.00

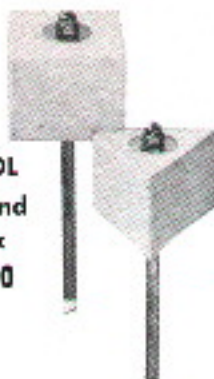

SQUARE AND TRIANGLE
255 - \$3.50 each



SOLID FELT
Medium sound
Most used
253 - \$3.00



SOLID WOOD
Rock and roll
and bombs
254 - \$2.00

Camco HICKORY DRUM STICKS

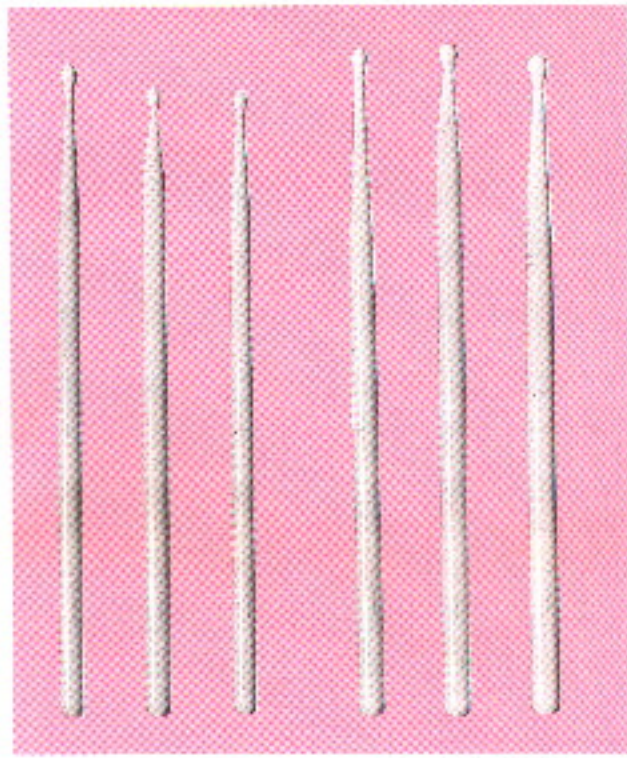
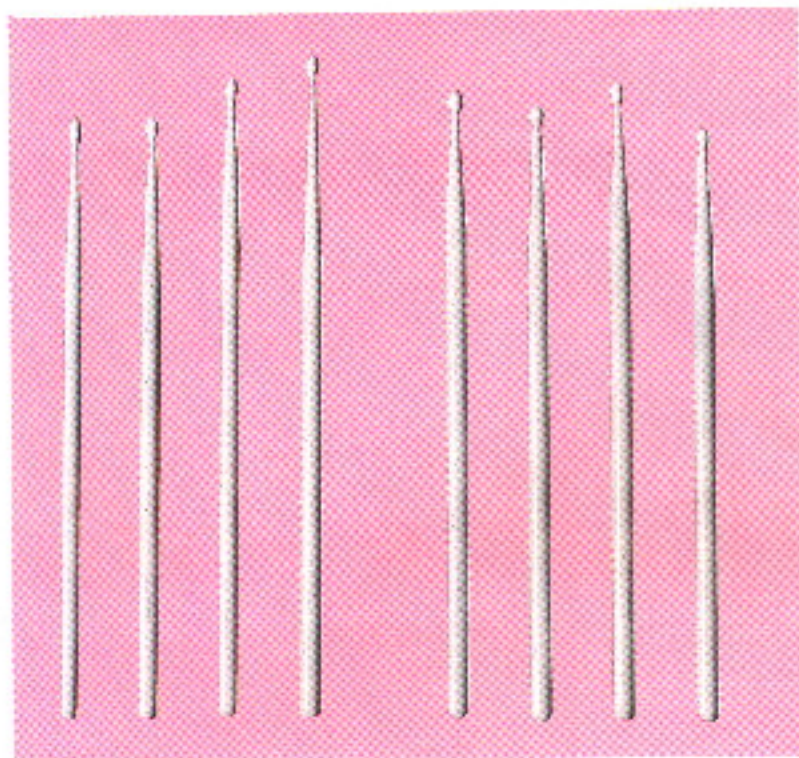

PEE WEE 7-A 0-B 1-A

2-A 3-A 5-A 6-A

JAZZ MODELS

Extra light weight

15" 15½" 16¼" 17"

DANCE AND SCHOOL MODELS

Light weight

15¾" 15½" 16" 15"

CONCERT MODELS

Medium weight

16½" 15¾" 16"

PARADE MODELS

Heavy weight

17" 17" 17½"

We invite drummers to compare our sticks with others. It will readily be noticed that these are "ultra" models. Two new extra operations have been added that have not been heretofore employed. The thoroughly dried hickory is the best obtainable and our workmanship shows in every stick. **\$1.60 pr.**

**NEW . . . ASTRO OAK
DRUM STICKS
\$1.60 pr.**



MODELS

5-A
7-A
8-A
Pee-Wee
2-B
5-B
3-D
8-D
1-S
2-S
3-S

NYLON TIP STICKS \$1.95 pr.



5-A Nylon



7-A Nylon

Camco PRACTICE PADS

Natural Gum Rubber on all Pads . . . Rubber Non-slip Feet . . . Red Glossy Enamel Finish

The "PROFESSIONAL" 9"x7"
1210 — \$5.50



The "STANDARD" 8"x7"
1215 — \$3.00



The "HEAVY DUTY" 9"x7"
1212 — \$5.50



Natural Gum
The 6" RUBBER DISC
1230 — \$1.50

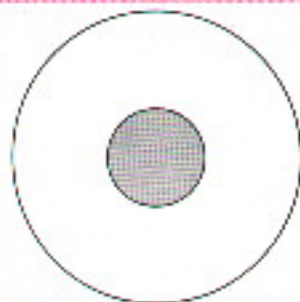
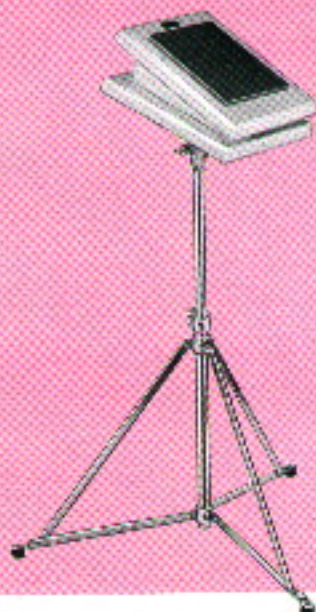

PRACTICE PAD

Has 6" Round Live Rubber Pad in Center. Protects Head in Case.

1100-14 for 14" DRUM

PRICE \$3.00

PRACTICE PAD STAND

1160 — Stand Only \$8.50

Camco WIRE BRUSHES "The Choice of Most Professionals"



Rubber Covered Handles
Loop Ends
1070
Pair — \$1.80



Rubber Covered Handles
Ball Ends
1072
Pair — \$1.90



Plain Aluminum Handles
Loop Ends
1074
Pair — \$1.60



Plain Aluminum Handles
Ball Ends
1076
Pair — \$1.80

CAMCO BASS DRUM STICKS



Lamb's Wool
Double End
Extra Length
17½" Overall

1001
\$5.50

Lamb's Wool
Double End
Regular Length
16" Overall

1002
\$5.50

Lamb's Wool
Single End
Wood Grip
15" Overall

1003
\$5.00

Lamb's Wool
Single End
With Sling
15" Overall

1004
\$6.00

Felt Hi-Grade
Medium Hard
Double End
13½" Overall

1005
\$4.50

Felt Hi-Grade
Medium Hard
Wood Grip
13" Overall

1006
\$4.00

Felt Super Grade
Hard Wood Grip
13" Overall

1007
\$4.50

Felt Hi-Grade
Medium Hard
With Sling
13" Overall

1008
\$6.00

Felt Hi-Grade
Medium Wool
Grip With Sling
13" Overall

1009
\$6.50

CAMCO TYMPANI STICKS

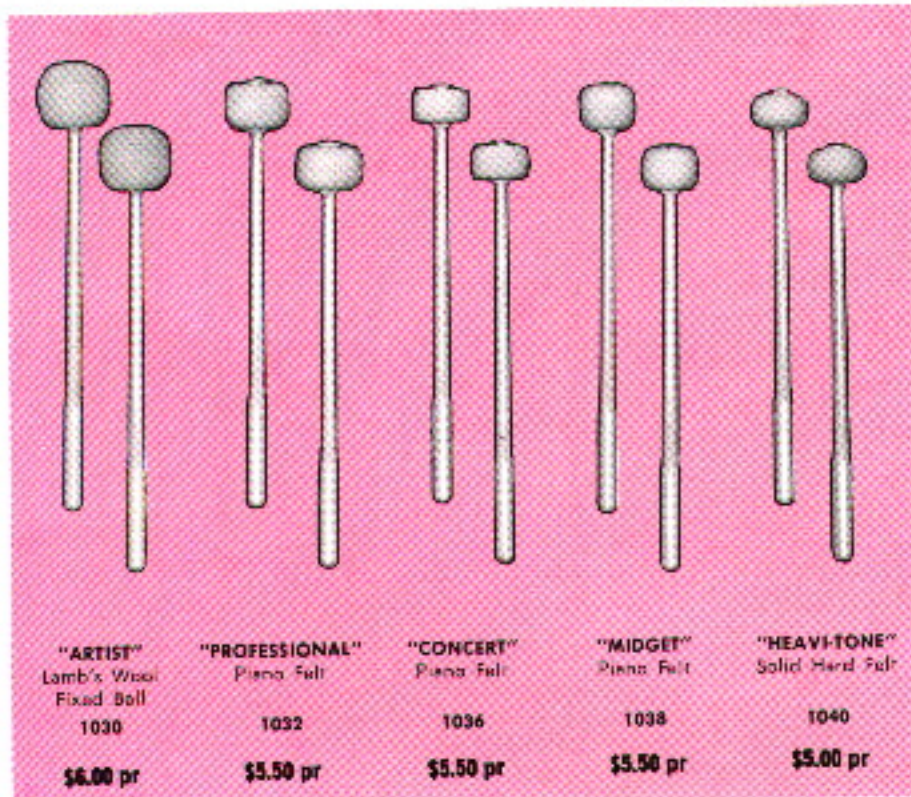

"ARTIST"
Lamb's Wool
Fixed Ball
1030
\$6.00 pr

"PROFESSIONAL"
Piano Felt
1032
\$5.50 pr

"CONCERT"
Piano Felt
1036
\$5.50 pr

"MIDGET"
Piano Felt
1038
\$5.50 pr

"HEAVY-TONE"
Solid Hard Felt
1040
\$5.00 pr



LAMBS
WOOL
830
\$6.50
pr.

METAL HANDLES



PIANO
FELT
838
\$6.00
pr.



SOLID
FELT
940
\$5.50
pr.

AVEDIS ZILDJIAN CYMBALS

No other make of cymbal in the world has the wide endorsement of the Avedis Zildjian brand. They have that "something" in blare, brilliance and rich sounds that has never been equalled. That, of course, is the reason the great majority of professional drummers, as well as concert band and symphony orchestra conductors, choose them above all others both in this country and abroad. Avedis Zildjian and his sons—Bob and Armand—personally mix the secret alloy in a closely-guarded laboratory, just as it was formulated in 1623. After casting they are fired, hammered, shaped and tempered many times under high temperatures. All of this (and much more) plus great skill, assures the resonance and strength for which they are world-famous.

Please specify thickness desired.	8"	16.00B
Extra Thin	10"	20.00B
Thin	12"	30.00B
Medium	13"	35.00B
Medium Heavy	14"	40.00B
Heavy	15"	45.00B
	16"	50.00B
	17"	55.00B
	18"	60.00B
	19"	65.00B
	20"	70.00B
	21"	75.00B
	22"	80.00B
	24"	100.00B

We carry a large stock of all sounds . . . If you will describe the usage intended — and size of organization—we will be glad to make careful personal selections.

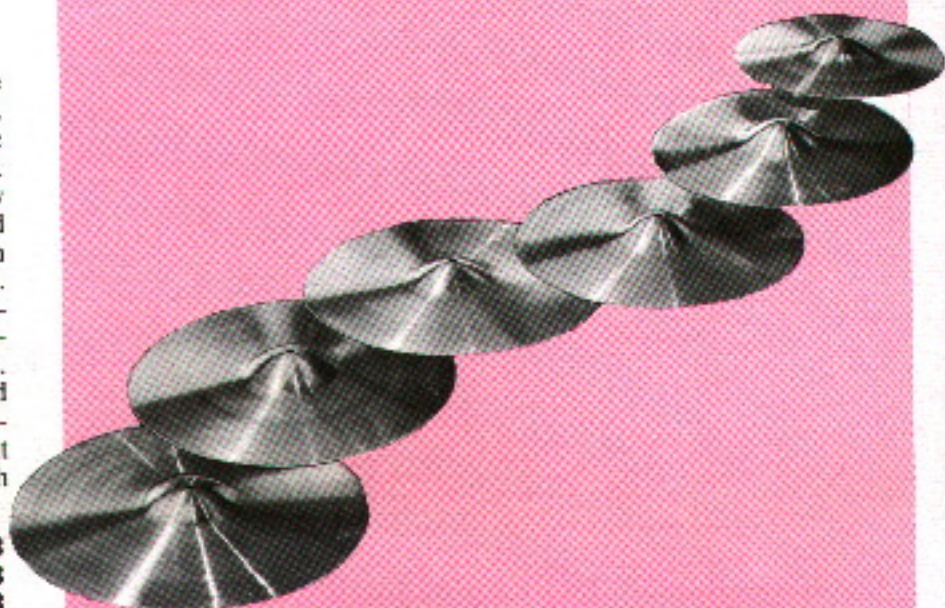

AVEDIS ZILDJIAN SIZZLE CYMBALS

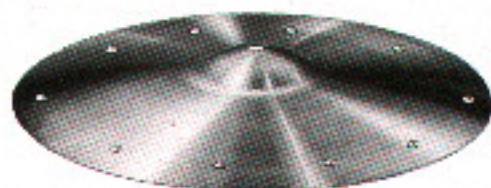

Exactly the same cymbals as the Avedis Zildjian listed above, with sizzle rivets added. Use the same prices for the same size. Please state number of rivets desired.

GREEKO CYMBALS



Nickel Silver—3½" and 3¼" with hoop clamp.

222 Pair \$5.00 pr.

FINGER CYMBALS



Brass alloy. Highly polished. The tones are brilliant. 2½" diameter.

220 Set of 4 \$6.00 set

AVEDIS ZILDJIAN GONGS AND STANDS

Cast of Zildjian Metal. Deep, rich, powerful, realistic gong tones.

20"	\$ 80.00B
22"	90.00B
24"	120.00B
26"	140.00B
28"	180.00B

1592 Gong Stand, Folding Legs.
Ring Made to Order.
State Size \$30.00

KRUT CYMBALS - ENGLISH IMPORTS

12"	\$ 8.90 ea
13"	11.40 ea
14"	13.50 ea
15"	16.00 ea
16"	19.80 ea
18"	25.80 ea
20"	33.00 ea
22"	41.40 ea

For Rivets in Cymbal — add \$2.00

AVEDIS ZILDJIAN CYMBALS

No other make of cymbal in the world has the wide endorsement of the Avedis Zildjian brand. They have that "something" in blare, brilliance and rich sounds that has never been equalled. That, of course, is the reason the great majority of professional drummers, as well as concert band and symphony orchestra conductors, choose them above all others both in this country and abroad. Avedis Zildjian and his sons—Bob and Armand—personally mix the secret alloy in a closely-guarded laboratory, just as it was formulated in 1623. After casting they are fired, hammered, shaped and tempered many times under high temperatures. All of this (and much more) plus great skill, assures the resonance and strength for which they are world-famous.

Please specify thickness desired.	8"	16.00B
Extra Thin	10"	20.00B
Thin	12"	30.00B
Medium	13"	35.00B
Medium Heavy	14"	40.00B
Heavy	15"	45.00B
	16"	50.00B
	17"	55.00B
	18"	60.00B
	19"	65.00B
	20"	70.00B
	21"	75.00B
	22"	80.00B
	24"	100.00B

We carry a large stock of all sounds . . . If you will describe the usage intended — and size of organization—we will be glad to make careful personal selections.

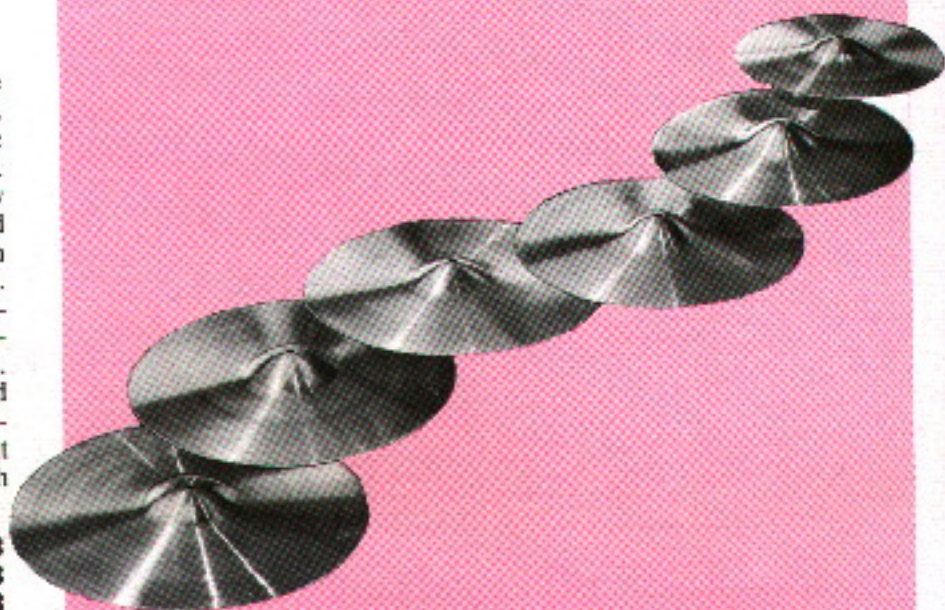

AVEDIS ZILDJIAN SIZZLE CYMBALS

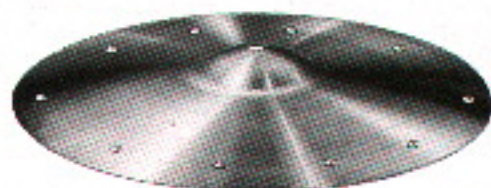

Exactly the same cymbals as the Avedis Zildjian listed above, with sizzle rivets added. Use the same prices for the same size. Please state number of rivets desired.

GREEKO CYMBALS



Nickel Silver—3½" and 3¼" with hoop clamp.

222 Pair \$5.00 pr.

FINGER CYMBALS



Brass alloy. Highly polished. The tones are brilliant. 2½" diameter.

220 Set of 4 \$6.00 set

AVEDIS ZILDJIAN GONGS AND STANDS

Cast of Zildjian Metal. Deep, rich, powerful, realistic gong tones.

20"	\$ 80.00B
22"	90.00B
24"	120.00B
26"	140.00B
28"	180.00B

1592 Gong Stand, Folding Legs.
Ring Made to Order.
State Size \$30.00

KRUT CYMBALS - ENGLISH IMPORTS

12"	\$ 8.90 ea
13"	11.40 ea
14"	13.50 ea
15"	16.00 ea
16"	19.80 ea
18"	25.80 ea
20"	33.00 ea
22"	41.40 ea

For Rivets in Cymbal — add \$2.00

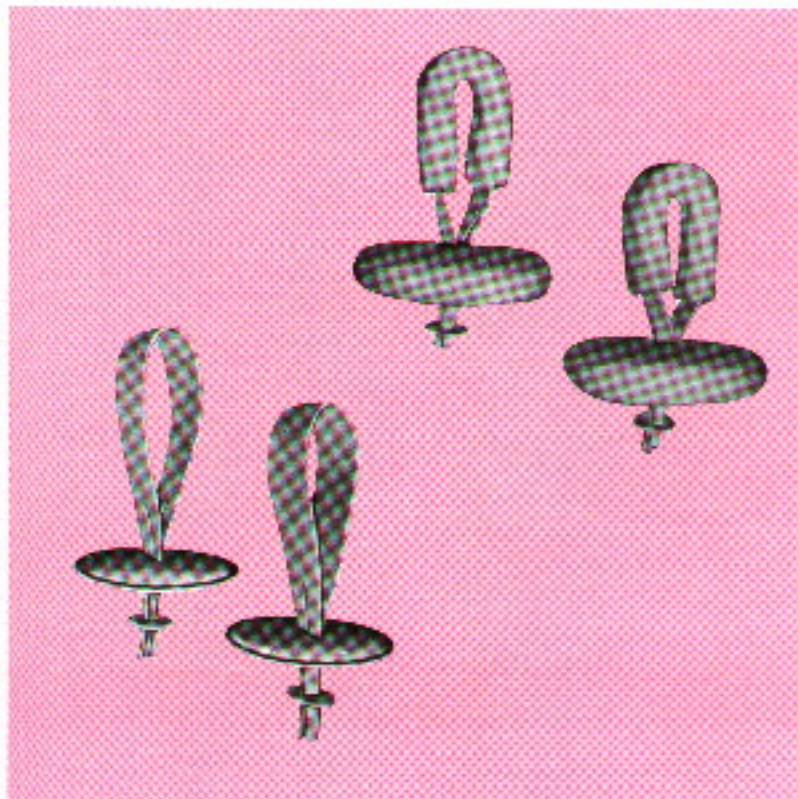

CYMBAL STRAPS AND PADS

These cymbal straps and pads are cut with "a little extra" in length, width, and thickness—a little larger than most models. This gives longer wear and is a great assist in overcoming fatigue and the tempo problem. Made of top grain "pearl elk" leather. Note that we supply knot washers.

REGULATION

- 1051 Straps, Pair \$1.80
 1052 Pads, Pair 2.50

LAMB'S WOOL COVERED

- 1054 Straps, Pair \$3.50
 1056 Pads, Pair 6.00



BAND CYMBAL HOLDER

Heavy extra strong holder with two "Camco" hoop clamps that prevent slipping.

- 1427 Chromium AAA \$6.50

THE CORRECT WAY TO TIE A CYMBAL KNOT



Lay the four leather ends flat in the cymbal cup

Fold No. 1 to the right and over No. 2

Fold No. 2 downward and over No. 1

Fold No. 3 to the left and over No. 2

Fold No. 4 upward over No. 3 and under No. 1. Pull ends tight.

WOOD CYMBAL HANDLES

- 249 Pair \$2.50



'CHING-RING'



CHING-RING
 7" STEEL SOUND-RESONATING RING
 8 pr. QUALITY CHINGLES
 ADJUSTABLE STEEL STRAP
 FINE FINISH
 \$11.95

CAMCO'S NEW ADJUSTABLE THROW OFF CYMBAL SIZZLER

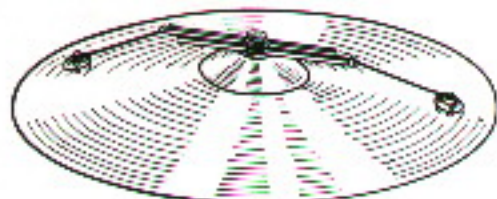

Sizzler On

No. 730
 Price \$3.60

Patent No.
 3,009,379

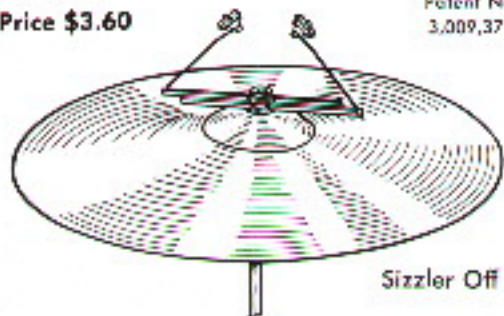

Sizzler Off

PLASTIC DRUM HEADS

CRISP, EASY PLAYING,
EVEN TENSION DRUMS
ASSURED... RAIN OR SHINE

Thousands now in use among leading professionals and in the schools.

CAMCO TOM-TOM OR BATTER SIDE

For 12" Shell.....	\$7.50
For 13" Shell.....	7.50
For 14" Shell.....	7.50
For 15" Shell.....	7.50
For 16" Shell.....	7.50

CAMCO SNARE SIDE

For 13" Shell.....	\$6.50
For 14" Shell.....	6.50
For 15" Shell.....	6.50
For 16" Shell.....	6.50

TYMPANI

25".....	\$21.00
28".....	24.00

WEATHER KING BATTER SIDE OR TOM-TOM

For 13" Shell.....	\$7.00
For 14" Shell.....	7.50
For 15" Shell.....	8.00
For 16" Shell.....	8.50

WEATHER KING SNARE SIDE

For 13" Shell.....	\$6.00
For 14" Shell.....	6.50
For 15" Shell.....	7.00
For 16" Shell.....	7.50

CAMCO BASS DRUM

For 18" Shell.....	\$15.00
For 20" Shell.....	\$17.00
For 22" Shell.....	18.00
For 24" Shell.....	19.00
For 26" Shell.....	21.00
For 28" Shell.....	22.00
For 30" Shell.....	23.00
For 32" Shell.....	25.00

Please Order by Size of Drum Shell Only

REMO VERSATILIC DRUM PRACTICE SET



Model RPS 10 - \$70.00B

PLASTIC BANJO HEADS

11" \$8.00

REMO TUNABLE PRACTICE PADS

Tension them like a drum, they feel like a drum, provide a realistic approach to the development of superior all around drum techniques.

Model RT 6".....	\$7.50
Model RT 8".....	\$10.00
Model RT 10".....	\$12.00



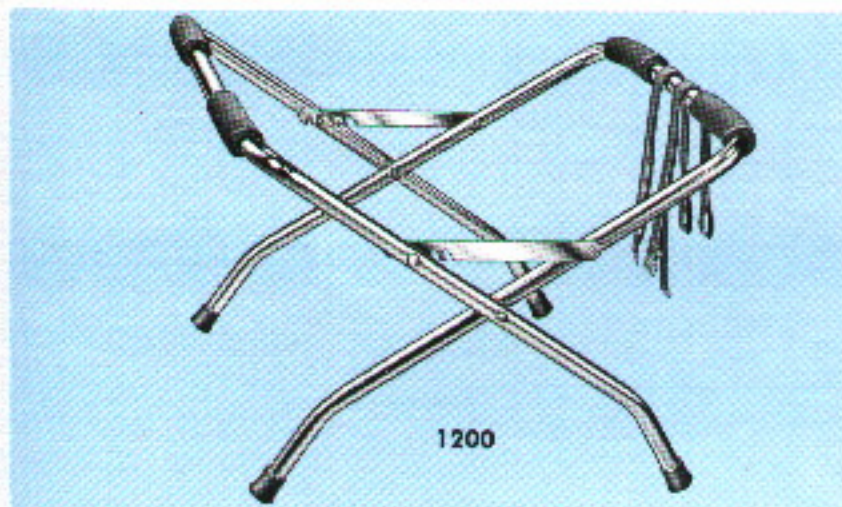

1200



1048



23
26

No. 114

355

4447

4453

1290

BASS DRUM RACK

Over 1,000 high school, college and professional bass drummers are now using this—the top prize winner of all bass drum racks. Many have voluntarily stated that it is the strongest and best looking rack they have ever seen. Made of 1" diameter steel tubing instead of the usual 3/4" size. All chrome plated. It also opens wider and will accommodate the largest drums.

1200 Chrome\$25.00

SOLID WOOD BASS DRUM BEATERS

Solid rock maple. Natural lacquer finish. Usually used in pairs for the loud rudimental beats on parade. 12 1/2" Overall.

1048 Each\$2.50

ACME DRUM MAJOR WHISTLES

All Metal—Easy Blow and Very Loud.

23 Small 1.65

26 Large 2.00

KEY HOLDER

Mounts in Shell — Always handy.

No. 114\$1.00

PARADE DRUM EYE FOR SLING SNAP HOOK

Fits under square head rod.

355 Chrome40¢

356 Bass Drum Hook\$1.00

WEB DRUM SLINGS

2" stout webbing. Fine Hardware.

SNARE DRUM

4447 White 2.60

BASS DRUM

4453 White 5.00

COMBINATION WRENCH and KEY

1290 1.50

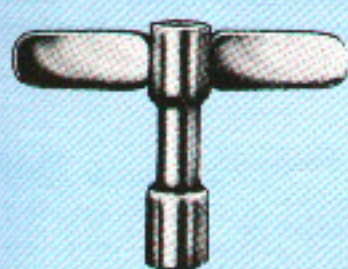

CAMCO DRUM KEY

1275 50¢

- Extra Heavy
- Extra Strong

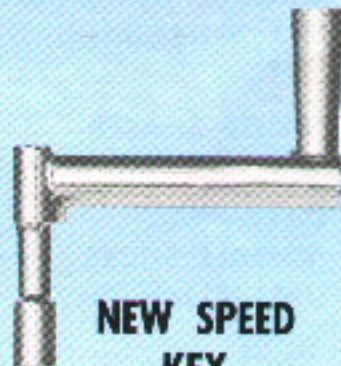

NEW SPEED KEY

1280\$1.50



PARADE LEG REST

Self-aligning adjustment. Keeps drum from swaying.

4434 Nickel\$4.80

4437 Chrome 6.75



1530
1531



1104 1103 1102 1101

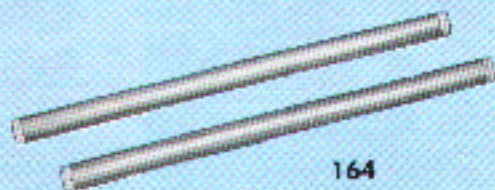

164



122

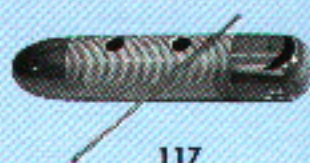

117

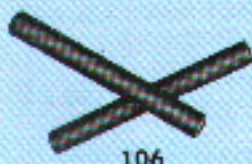

106



100M



119



100S

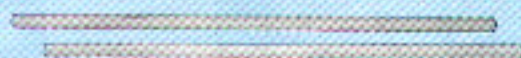

165

CAMCO WOOD BLOCKS

Made of one-piece rock maple. Rich "clock" (not "click") sound.

1530	6 1/2"	\$3.00
1531	7 1/2"	\$3.50

CLAVES

Genuine grenadilla wood, professional size.

106	Pair	\$3.00
-----	------	--------

MARACAS

These are genuine Mexican handmade—hand finished. They come in various colors with hand carved floral designs. Available also in a natural wood finish with hand-painted native scenes.

100S	Overall colors and hand-carved floral designs.
Pair	\$4.00

100M	Overall colors and hand-carved floral designs.
Pair	\$5.00

MARACA STICKS

Used on tom-toms for a combined maraca effect.

164	Pair	\$3.00
-----	------	--------

COW BELLS

These pressed steel bells are polished and finished in a new Black Finish.

7 1/4"	5 1/4"	4 1/4"	3 1/4"
1104	1103	1102	1101
\$3.80	\$3.00	\$2.80	\$2.20

GUIROS

Handmade wood guiros. Highly polished. Lacquer colors.

117	With Scratcher	\$5.40
-----	----------------	--------

WOOD SHAKER

122	Hand Made. Polished	\$5.40
-----	---------------------	--------

TIMBALE STICKS

165	15" Long. Pair	60¢
-----	----------------	-----

METAL-TUBO-SHAKERS

Plenty of volume. Will cut thru large band. Very effective.

119	Large	\$5.00
-----	-------	--------

4732
4722
4721
4720



989



56
59



27

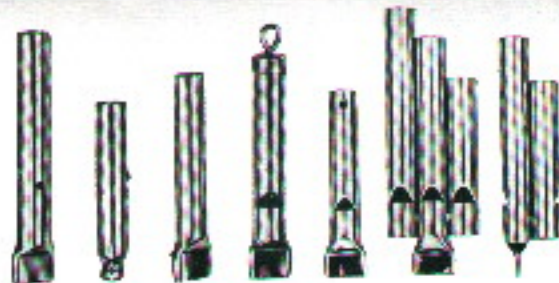

541 553 556 135 827 824 826



427

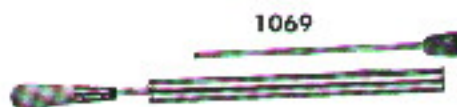

1069



564



505



506



501



116



560



568

567

566

"NO TACK" TAMBOURINE

Solid maple shell. No tacks or staples. Head held by metal band fitting into recessed groove in shell. Easy to replace heads.

989 10" Diameter—12 Pair Jingles.....\$10.75

REGULAR TAMBOURINES

Maple shells — calf heads. Excellent tambourines. Low priced.

4732 10"—17 Pr. Jingles, Double Row\$9.80

4722 10"—9 Pr. Jingles 8.50

4721 8"—6 Pr. Jingles 6.00

4720 7"—5 Pr. Jingles 5.00

CASTANETS

505 1 Pair on Handles\$3.50

506 2 Pair on Handles 4.50

501 2 Pair for Fingers 2.50

BIRD WHISTLES

56 Warbler—Large\$3.50

59 Canary—Small 2.50

ACME SIREN WHISTLE

27 Made in England\$4.50

SLIDE (SONG) WHISTLE

427\$4.50

POP GUN

1069 Sure Fire, Loud\$9.00

METAL IMITATIONS

541 Shanghai Rooster\$1.50

553 Hen Cackle 1.50

556 Baby Cry 1.50

135 Bob White 1.80

827 Cuckoo 3.50

824 3-Tone Train 9.00

826 2-Tone Train 7.50

SLAP STICK

116 Rock Maple\$4.50

WOOD RATTLE

Clamps to bass drum hoop. Rock maple ratchet in a metal frame. Very loud and durable.

560\$6.80

SLEIGH BELLS

568 25 Bells\$11.00

567 13 Bells 7.00

566 12 Bells 5.00

STEEL BELL PLATE

564 7"x9"x1/8"—Mallet included\$6.00



1429



810 807
809 806
808 805



429-N



430-N



1541-N



443-N

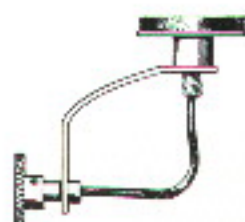

1115



1426

TRIANGLE HOLDER

You can be sure that this extra strong holder will remain in place. Gut suspension cord.

1429-Chromium AAA \$3.00

TRIANGLES

Fine grade steel. Brilliant tones. Heavily plated. Striker included.

810	10"	\$3.15	807	7"	\$1.85
809	9"	2.60	806	6"	1.60
808	8"	2.10	805	5"	1.40

ONE COW BELL HOLDER

429-N Nickel \$1.50

TWO COW BELL HOLDER

430-N Nickel \$2.50

WOOD BLOCK HOLDER

1541-N Nickel \$1.20

WOOD BLOCK AND COW BELL HOLDER

443-N Nickel \$2.00

INTERNAL SNARE DRUM MUFFLER

Only Vertical Control on Market. Very Fast.

1115 \$3.00

CAMCO BASS DRUM MUFFLER

This new idea bass drum muffler has risen to a top favorite in six months time. No springs to deteriorate or rust. The pressure adjustment is directly in center of felt disc. Any color pearl to match your drums. Your choice of Pearls. Please state pearl desired.

1426P All Metal parts chrome plated \$6.00

1426C Chrome Disc 6.00

1430 3' x 25' Bass Felt Muffler \$1.00

"SNAPPI" COILED WIRE SNARES



1240	12 Strand for 13" Drums	\$3.30
1241	12 Strand for 14" Drums	3.30
1242	12 Strand for 15" Drums	3.30
1245	16 Strand for 14" Drums	3.60
1247	16 Strand for 15" Drums	3.60
1250	20 Strand for 14" Drums	3.80
1251	20 Strand for 15" Drums	3.80
1252	16 Strand for Super	5.00

Camco MALLETS



- | | | | | | | | | |
|---|---|---|---|---|---|---|--|--|
| C-1
1" Soft
Yellow
Rubber
\$2.20 | C-2
1" Medium
Red Rubber
\$2.20 | C-3
1 1/8"
Hard Blue
Rubber
\$2.20 | C-4
1 1/8"
Hard Gray
Rubber
\$2.20 | C-5
1" Hard
White
Plastic
\$2.50 | 692
3/4" Solid
Brass Balls
\$1.50 | C-6
1 1/8" Hard
Red Yarn
\$4.50 | C-7
1 1/8" 1/8"
Hard Blue
Yarn
\$4.50 | C-8
1 1/8" Med.
Soft Yellow
Yarn
\$4.50 |
|---|---|---|---|---|---|---|--|--|

- C-1** Ideal for practice and 4 mallet playing
- C-2** Excellent for ensemble and solo
- C-3** For greater volume
- C-4** For Xylophone and bells
- C-5** For Xylophone and bells
- 692** For Bells metallic effect
- C-6** For Vibe and Marimba - 2, 3, and 4 mallets
- C-7** Special for Vibe - 2, 3, and 4 mallets
- C-8** For Marimba - 2, 3, and 4 mallets

BELL-LYRA MALLET



New balance assures accurate aim—positively guaranteed unbreakable balls. The strongest mallets ever made. You can be sure that the balls will not break. Shafts are of 1/8" special alloy carbon magnesium steel made to our order. The hand grips are semi-hard ribbed rubber. These exclusive features provide a new feel and balance that means better control and therefore better playing technique. One of the most outstanding inventions ever presented in the percussion dept. They are slightly higher in cost because of better materials and workmanship, but they will outlast dozens of the old style models, therefore are much cheaper in the long run.

1050 Pair\$3.80

INSTRUCTION BOOKS



DRUM METHOD No. 1
\$2.50B

DRUM METHOD No. 2
\$2.50B



Vol. 1 \$2.00
Vol. 2 2.00
Vol. 3 2.00
Vol. 4 2.00

HERTA'S PARADE
by Sheldon Elias

\$3.00

A percussion ensemble for high school musicians. Player I marimba, player II snare drum and triangle, player III bass drum and suspended cymbal. An ideal piece for featuring the percussion section in a concert.

LEATHER BELL-LYRA SLINGS

Fine top-grain sole leather.



Single,	{	4855 White	\$10.00
		4853 Tan	10.00
Double,	{	4857 White	15.00
		4856 Tan	15.00

ZIPPER DRUM COVERS

All sizes are shell measurements only — allowance is made for hoops. Please state type and size when ordering.

SNARE DRUM

	Mack-Intosh	Dura-lyte		Mack-Intosh	Dura-lyte
4x13	\$7.80		5½x14	\$7.80	\$9.20
4½x14	7.80		6½x14	7.80	9.20
5x14	7.80	9.20	8x15	7.80	10.05

PARADE DRUM

	Mack-Intosh	Dura-lyte		Mack-Intosh	Dura-lyte
10x14	\$8.40	\$10.50	12x15	\$9.00	\$10.05
10x15	8.70	10.50	12x16	9.00	10.05

TOM-TOM

	Mack-Intosh	Dura-lyte		Mack-Intosh	Dura-lyte
8x12	\$8.10	\$9.20	14x14	\$9.00	\$10.50
9x13	8.10	9.20	16x16	9.00	11.10

BASS DRUM

	Mack-Intosh	Dura-lyte		Mack-Intosh	Dura-lyte
14x18	\$13.00	\$15.10	10x28	\$16.00	\$18.90
14x20	13.50	15.10	14x24	14.25	18.90
14x22	13.50	15.10	14x28	15.90	18.00

DURALYTE CYMBAL BAGS

13" and 14"	\$12.30	15" and 16"	\$12.90
18"	13.80	20"	15.00
22"	15.80	24"	17.60

FIBRE CASES

SUPER CARRY-ALL CASE

No. 21 Extra Large. Will hold 22" Cymbal has tray and partition	\$46.90 B
No. 21-W Same but with wheels	55.60 B

REGULATION CARRY-ALL CASE

No. 20 Has tray and partition Will hold 15" Cymbal and extras	\$34.00 B
---	-----------

STUDENT CASE

Deluxe Case - Blue	\$21.00
--------------------------	---------

TRAY FRAME CASE

No. 40 Metal edge frame will hold 16" Cymbal	\$35.00
--	---------

PLAIN FIBRE CASE

No. 30 Plain edge frame will hold 16" Cymbal	\$28.00 B
--	-----------

TELESCOPE SNARE DRUM

Will take drums up to 8" shell depth 14" dia. shell	\$16.80 B	15" Dia. shell	\$17.00 B
---	-----------	----------------------	-----------

PARADE DRUM

10x14	\$19.80 B	12x16	\$22.80 B
12x15	22.00 B		

TOM-TOM

8x12	\$17.50 B	14x14	\$22.00 B
9x13	18.00 B	16x16	23.60 B

BASS DRUM

14x18	\$31.00 B	14x26	\$42.35 B
14x20	40.00 B	14x28	\$43.45 B
14x22	40.40 B	10x28	\$42.35 B
14x24	41.25 B		

SQUARE SNARE 14"	\$14.50 B
------------------------	-----------



No. 21



No. 20

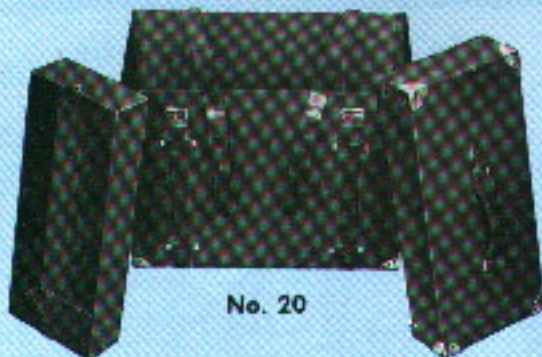

No. 40



No. 30



TELESCOPE FIBRE CASES



SQUARE SNARE

REPLACEMENT PARTS LIST

STRAINERS

830	Aristocrat Strainer	\$9.50
845	Economy Strainer	4.50
841	Snare Jaw	1.00

TENSION CASINGS

846	Aristocrat Snare Casings	\$1.40
847	Aristocrat Bass Casings	1.60
848	Tuxedo Snare Casings	1.40
849	Tuxedo Bass Casings	1.60
851	Collar Screw Hoop for Single Flange Hoop40
852	Claw Hook for Bass Drums	1.00
853	Claw Hook for Parade Drum	1.00
856	Casing for Cymbal Holder or Tom Tom Legs	1.60
854	Tympani Handle Rods (State Size)90

HI-HAT PARTS

800-202	Leather Strap	\$.45
800-1	Spring30
800-2	Round Felt Washer16
800-3	Round Steel Washer20
800-4	Round Washer and Bushing30
800-5	Base Casting	2.00
800-6	Large Wing Screw for Base60
800-7	Strap Screw20
800-8	Hex Leg for Heel10
800-9	Crutch Tip for Leg on Heel10
800-10	Rubber Bumper and Screw for Heel10
800-11	Footboard Connection	1.00
800-12	Metal Hinge45
800-14	1/4-20 Wing Screw Wide Spread34
800-15	1/4-20 Wing Screw25
800-16	5/16-24 Wing Screw34
800-17	Clamp for Top Tube50

CRUTCH TIPS AND MISCELLANEOUS PARTS

1200-1	1" I.D. Tip for Bass Drum Rack	\$.30
800-13	Crutch Tip for 800-600-700 Stands10
9000-2	3/8" I.D. for Throne and Spurs10
9000-1	Locking Ring and Screw for Throne80
600-6	Large Knurl Nut for 600 Drum Stand40

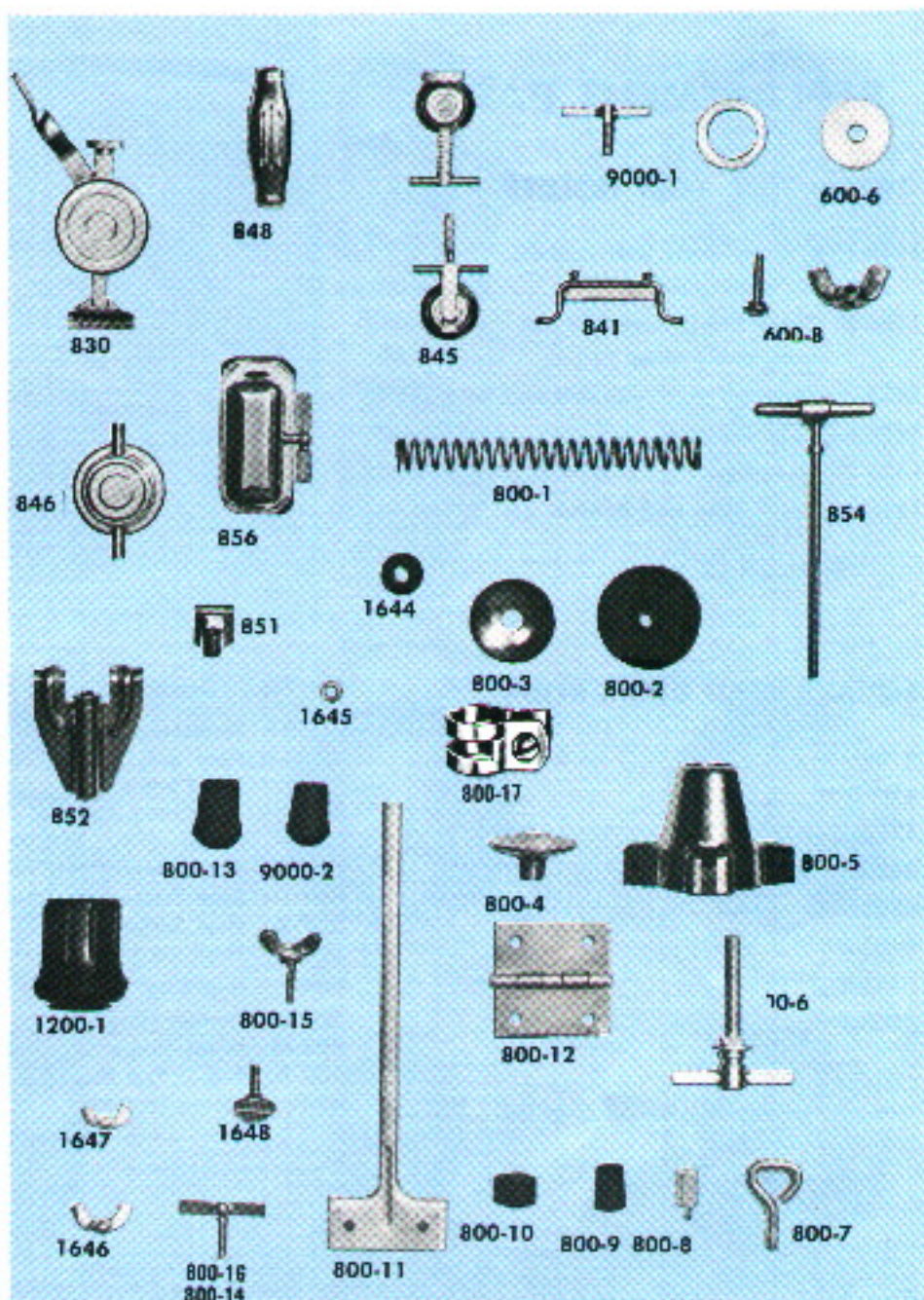

600-8	Bolt and Large Wing Nut25
1646	1/4-20 Wing Nut10
1647	10-24 Wing Nut08
1648	1/4-20 Thumb Screw12
1643	Rubber Cymbal Tube06
1644	Leather Washer10
1645	Tension Rod Washer06
1649	10-24 Thumb Screw10

COUNTER HOOPS

Chrome Triple Flange, Snare Side	\$9.50
Chrome Triple Flange, Batter Side	9.00
Wood Bass, Maple	6.00
Wood Bass, Lacquer	6.50
Wood Bass, Pearl Inlaid	7.50
Parade Hoop, Maple	3.00
Parade Hoop, Lacquer	3.50
Parade Hoop, Pearl Inlaid	4.50

REPLACEMENT PARTS

1435 — TOM TOM HOLDER PARTS

- 1435-1 Rail Complete with washers, bolts and nuts.....\$6.00
- 1435-2 Small Clamp complete nut, bolt, and washer 1.00
- 1435-3 Diamond plate with nuts and bolts 3.50
- 1435-4 Extension Rod 1.00
- 1435-5 Hex Key 1.00
- 1435-6 Rail Clamp and Ratchet..... 5.00

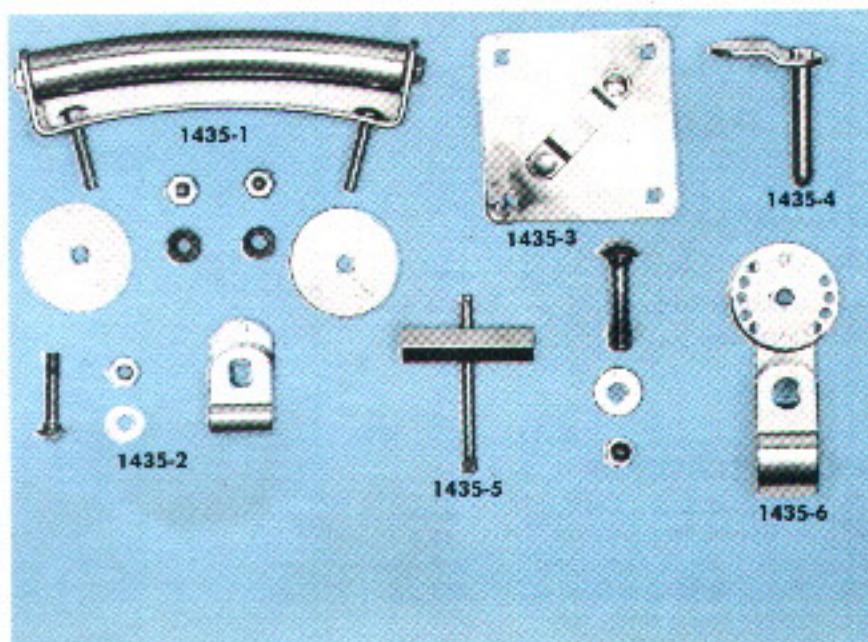

SQUARE HEAD DRUM RODS

- 4150-1½"\$.40
- 4187-1¾"40
- 4250-2½"40
- 4300-3"40
- 4350-3½"50
- 4400-4"50
- 4450-4½"50
- 4500-5"50

Chrome plated. All rod measurements are taken from under the collar to the end of the threads.

Part No.	Description	List Price	Part No.	Description	List Price
5000-F	Footboard only	\$4.00	403	Spring	\$.22
5000-H	Heel only	1.25	402	Spring Screw	.15
604	Toe Clamp Pin	.06	401	Rocker	.30
603	Toe Clamp Locking Screw	.40	400-A	Rocker and Spring Assembly	.82
602	Toe Clamp Casting	.85	307	Cam Side Bearing Nut	.05
601	Base Casting	6.00	305	Rocker Hub	.20
507-2	Heel Screws	.06	302-2	Bearing	.60
506-2	Footboard Screws	.06	300-A	Hex Shaft Assembly	2.75
504	Heel Clip	.15	203-2	Cam Strap Screws	.05
502-L	Leather Hinge	.30	202	Cam Strap	.45
502-M	Metal Hinge	.60	201	Cam Casting	1.25
500-A	Radius Rod Assembly	1.75	103	Hex Shaft Set Screw	.35
404	Spring Lock Nut	.20	102	Beater Shaft Set Screw	.35
			101	Beater Hub Casting	1.25
			5000-C	Complete Footboard	7.50
			202-N	Nylon Strap	.75

Camco Pedal Parts

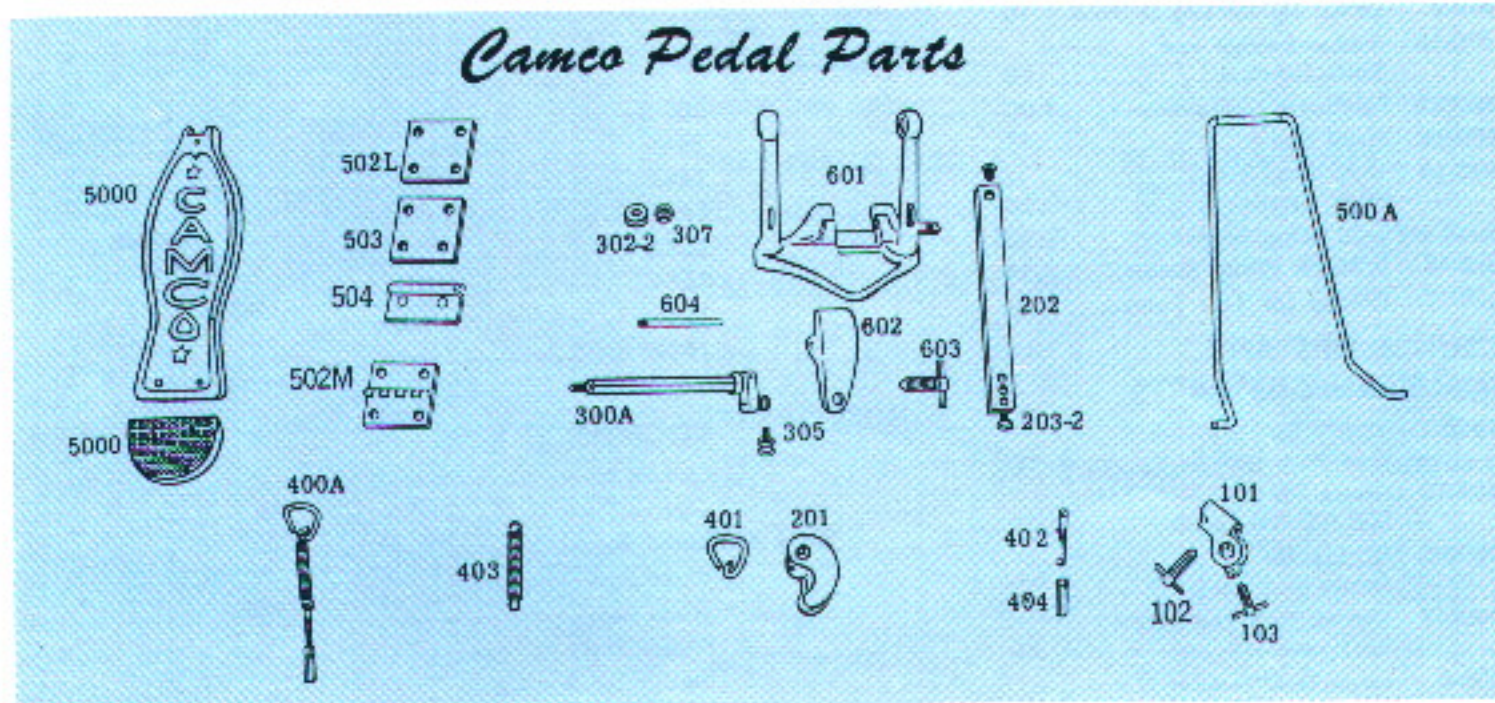

Kustom

ELECTRONICS, INC.

1010 WEST CHESTNUT
CHANUTE, KANSAS 66720

July 21, 1971

To: ALL KUSTOM AND KASINO DEALERS

Re: CAMCO DRUMS

Exciting news from Kustom Electronics, Inc!!!

Yes, it's true. Kustom Electronics has purchased the Camco Drum Company.

Our basic aim in serving you, the music dealer, has been to offer a complete line of quality music products. Camco Drums "fill the bill" with a complete line of quality drums and accessories.

Camco Drums have long been recognized as a leader in the drum industry. They are nationally recognized by their "round lug" hardware and nationally famous for their high quality hi-hats, Camco pedals, and other machined (not cast) hardware.

Camco Drums by Kustom will be a valuable franchise for you, resulting in extra sales and profits for your store.

Fill out the enclosed form so we may count you in our franchising plans.

Your immediate attention will be appreciated.

Yours in selling,

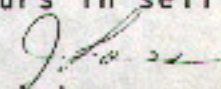
Jack Loss
Merchandising Manager

JL:ct
Enclosure: Camco Catalog
Dealer Form
Envelope



JOEY CASS
New York



JOE DUKES
Jack McDuff



RICK FRIGO
Chicago



NORM JEFFRIES
Hollywood Palace



STEVE RILLERA
Santa Ana



SID BULKINS
Las Vegas



MEL BROWN
Temptations



EDDIE KNIGHT
South Bend



HAP GORMLEY
New York



NORBY KING
Chicago



KALIL MADI
Big Tiny Little



TONY CASELLI
Chicago



PAUL HUMPHREY
Hollywood



ALAN LASCHIVER
Tustin-California



MARSHALL THOMPSON
Chicago



TONY DEE
"NTH" Hollywood



DENNIS WILSON
Beach Boys



JIMMY SMITH
Erroll Garner



JERRY PUTNAM
Puerto Rico



MORGAN GRANT
Hanolulu



FRANK KIM
Honolulu



ROSS HAYASHIDA
International Set



EDDIE SWAN
Los Angeles



BART TUNICK
Seattle



RED SPARKLE

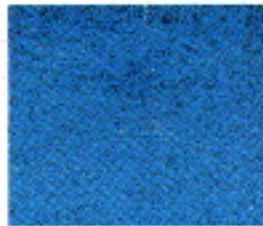

BLUE SPARKLE

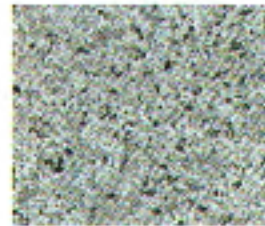

SILVER SPARKLE

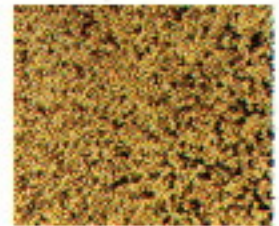

GOLD SPARKLE



GREEN SPARKLE



OYSTER PEARL



BURGUNDY SPARKLE



CHAMPAGNE SPARKLE

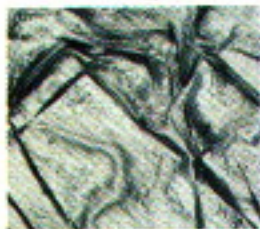

BLACK DIAMOND PEARLE

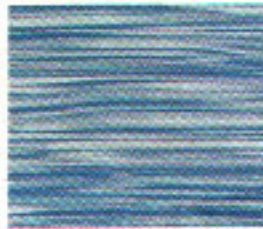

BLUE RIPPLE



BLACK RIPPLE



WHITE PEARL

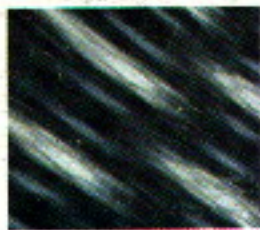

CHARCOAL MOIRE



BLUE MOIRE

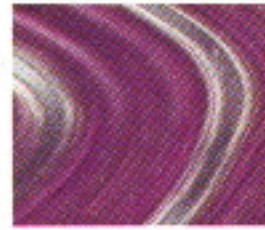

PURPLE MOIRE



GOLD MOIRE

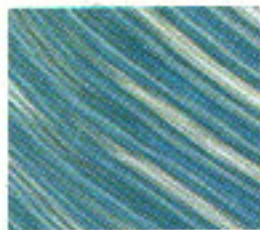

AQUA MOIRE



RED MOIRE

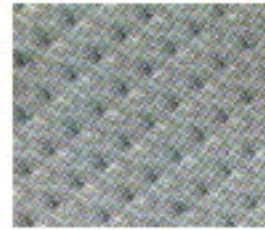

3-D



RED STAIN



EBONY STAIN



CLEAR MAPLE



WALNUT STAIN



MOSS GREEN STAIN

Custom
Camco DRUMS

KUSTOM ELECTRONICS, INC. — CHANUTE, KANSAS 66720