

# JUNIOR BEAT

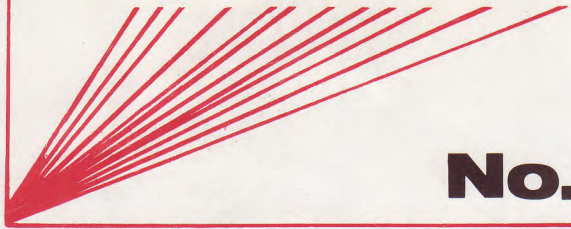

**No. 5**

## Drummer Profile **BRIAN BENNETT**



Brian is undoubtedly best known for his work with the Shadows whom he joined in 1962 when they were already a well established act. The success of the band has continued ever since. Although the band no longer tours on a regular basis, Brian is still kept very busy and has been involved in sessions as a drummer, arranger, conductor and producer and writing jingles for T.V.

A lot of his time recently has been

spent working with singer/actor Dennis Waterman including an hour long TV spectacular produced by Yorkshire Television.

Brian, who has been experimenting with drum synthesisers recently, is one of the few drummers who can put together a long solo routine and make it sound and look interesting to drummers and non-drummers alike. Part of his secret is in keeping to a simple approach, using basic rudiments and patterns, and then building

the whole thing up in an obvious and entertaining way.

The Shadows have also been touring the U.K. with sell-out concert dates in major cities.

Brian's Premier outfit comprises 22" bass drum, 13 x 9" & 14 x 10" double headed tom-toms, 16 x 16" tom-tom, 22" timpani and 5 1/2" deep snare drum. This is complemented by a set of Avedis Zildjian cymbals.

Dear Member,

I have very mixed feelings about this issue's editorial. I am moving on to pastures new, so it is the last time I will be writing to you. However, the Drummer's Club is growing all the time and I know that you will be kept up to date with all that's happening here at Premier in the future.

You'll already have seen our latest range of new outfits in the last edition of Talking Drums and if any of you want further information drop us a line.

In the course of the next year many more Premier clinics will be held up and down the country and you'll be kept informed, so that you don't miss your chance to see a top Premier drummer in action.

Finally, keep those letters coming, and I'd like to wish you all every success in the future.

Good luck.

*The Editor*

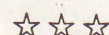
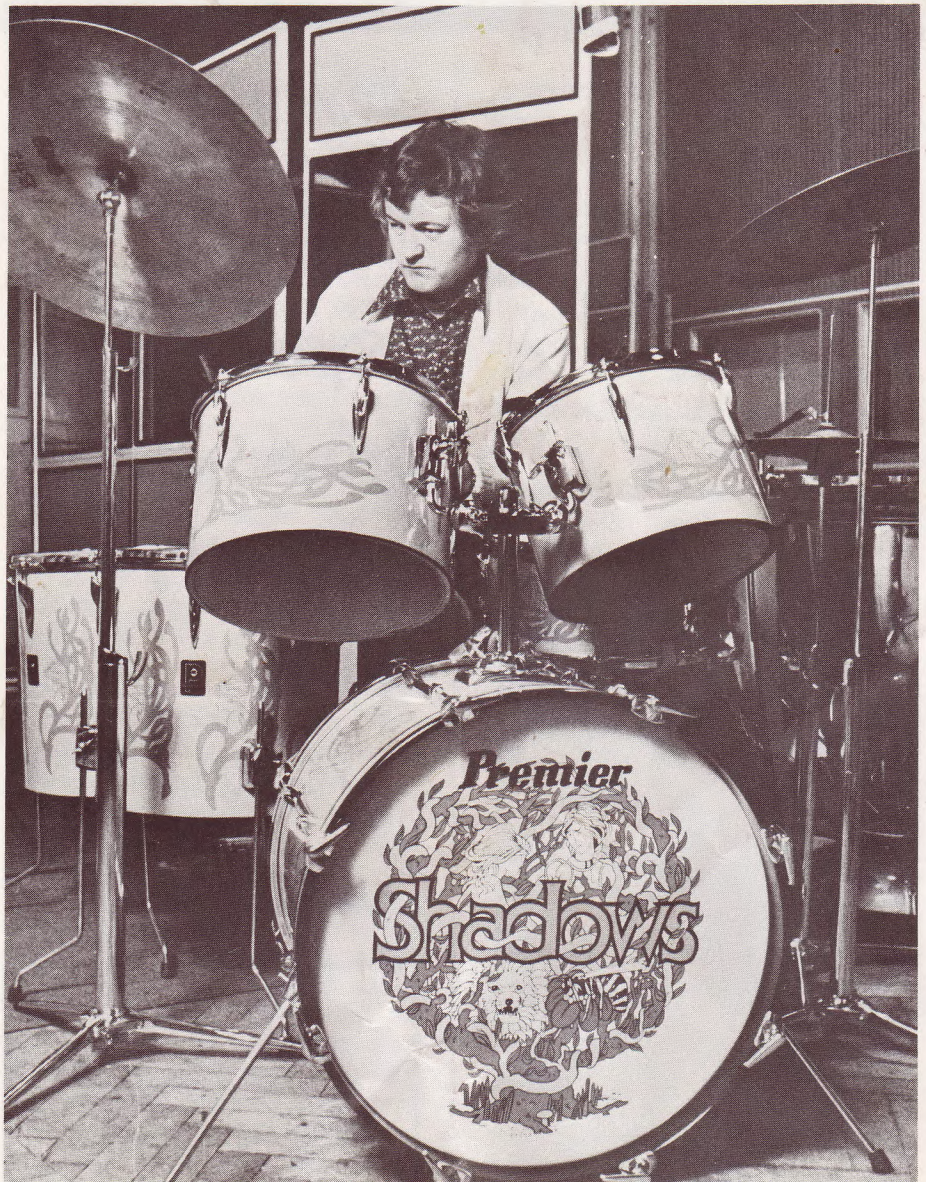

# Recent visitors to Premier

Amongst the many visitors to Premier since the last edition of Junior Beat have been

**Irv Cottler (Frank Sinatra)**

**Phil James  
(Premier Clinician)**

**Stan Bennett (Poacher)**

**Charlie Charles (Ian Dury)**

**Henry Harrison  
(New Vaudeville Band)**

**Pete York**

**Pete Spencer (Smokie)**

**Alan Platt (Wilko  
Johnson's Solid Senders)**

**Dave Tulloch (5 Hand Reel)**



*Irv Cottler*

## *Did you know that:*

The Junior Drummers Club now has members as far apart as Norway, Cyprus and Australia.

The hi-hat started life quite low

## **"Spot the Drummers" competition result**

The first correct entry drawn out of the hat was sent in by Tim Wilkins of 103 Bridgewater Drive, Northampton. Congratulations to you Tim, and your prize will be on its way to you shortly.

down (not hi) as a pair of cymbals underneath a spring-loaded foot-plate on the floor.

One of the best drummers we know is a girl called Christy Lee, and one of the best tuned percussion players is another girl called Heather Corbett — both British.

Before bass drum pedals were invented, the bass drum was stood at the side of the snare drum and the drummer hit it with his drumsticks. He had to be able to play a continuous mammy-daddy roll on the snare drum and, at the same time, keep the bass drum beat going by using the butt end of one of the sticks. If you ever come across an older drummer who remembers the technique, ask him to give you a demonstration — it's fascinating.

The world's biggest exhibition of musical instruments is held each year in Frankfurt, Germany, for nearly a week during February or early March for the benefit of suppliers and trade buyers.

Next year's British Musical Instrument Fair will be held at Olympia, London, for the first time and will be open to the public on Friday and Saturday, 27-28 July. Needless to say, Premier will have a stand with a good display of the latest products.

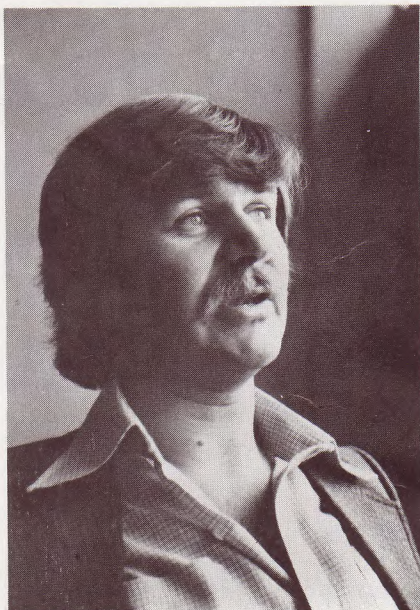

*Pete York*

***Premier***  
**1st IN PERCUSSION**

# Keith Moon



*KEITH MOON was a real character, a unique individual who achieved tremendous love, respect and admiration throughout the world. His sudden death was an unbelievable shock to*

*everyone, but he was already a legend who will never be forgotten. He was loyal to The Who, to Premier and, most of all, to himself. And his dedication was*

*so strong that he achieved everything he set out to do — a lesson to us all. But memories, however strong, are not enough; Keith Moon will be sadly missed.*

## NEWS BRIEFS

Professor James Blades O.B.E., will be lecturing at the American Percussive Arts Society's annual conference near Phoenix, Arizona, at the end of October. Then he'll be flying on to Canada and then to New York.

The first ever British Youth Band Championships will take place at Wembley, London, on 25th November. Thirty of the best bands in the country will play their hearts out in the large Wembley Arena before what is expected to be a capacity audience — most seats were sold by September but there are some left at £2 and £1.50. There will also be displays by the Central Band of the R.A.F., the Groovers Steel Band, and H.M. Band of Royal Marines. The winning band, 'British Champions', will appear in the next year's Royal Tournament at Earls Court and on BBC TV's Blue Peter. The whole event will be recorded by the BBC for TV transmission sometime before Christmas.

Such is the popularity and high standard of music being created by you youngsters that the

Schools Proms at London's Royal Albert Hall on 27, 28 and 29 November were also completely sold out 4 months in advance, which must be a record for that concert hall. Now, even some of the performers can't get seats.

Electronic drums are now a thing of the present, not the future. Latest newcomer to the market is the SDS 3 drum synthesiser produced by Arkay Sound Ltd. (Musicaid), 66 Radlett Road, Frogmore, St. Albans, Herts, England. It is described as a 4-channel polyphonic synthesiser producing an almost infinite variety of percussive sounds, and we must admit that it's very impressive. Premier make the drum pads for this synthesiser, but we are not responsible for its performance or sales — so if you want to know more you must contact Musicaid direct. We can tell you that the current price of the synthesiser with drum pads and connecting leads is £780 (including VAT) and that you will still need your existing drum kit plus between £100-£300 worth of PA amplifier and good quality speakers.

## UFIP CYMBAL CLINICS

Andrea Centazzo is an Italian, a superb drummer, a cymbal and gong specialist, drumming adviser to the UFIP cymbal company, and a lover of avant-garde jazz. Premier distributes the popular UFIP range in the U.K., and it will probably not surprise you that, whilst this edition of Junior Beat was being printed, Andrea toured Britain for a week with Premier doing special clinics to show off the tremendously varied sounds that are possible with various sizes and shapes of bronze. And look at his kit!



## MUFLING TOM TOMS AND SNARE DRUMS

1. One or two pieces of adhesive tape placed near the edge away from the player. This is a popular snare drum muffling technique for recording.

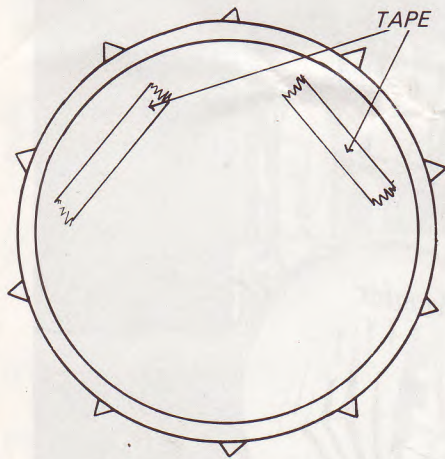

2. Cloth pad taped to drum head, usually just on tom toms. Very popular for recording.

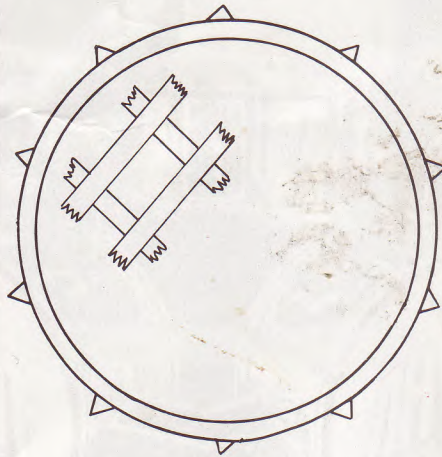

3. Internal tone control should be used carefully, especially on snare drum. Don't over-tighten tone control. Very little pressure is needed to effectively muffle snare drum ring.

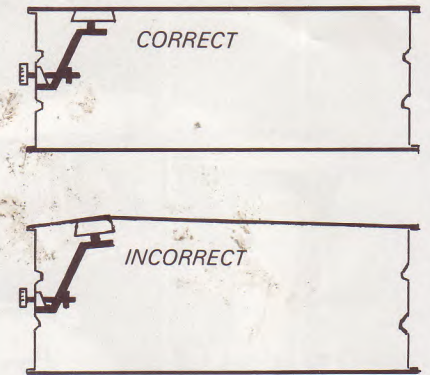

In the second illustration, the head is being unevenly tensioned from underneath, and the result is distorted sound with incorrect 'feel'.

## BASS DRUM MUFLING

1. Place one strip of felt underneath each head (Fig. 1). Strips may be moved closer to centre for more muffling. Do not place strip across exact centre of head. It will create a buzzing sound.

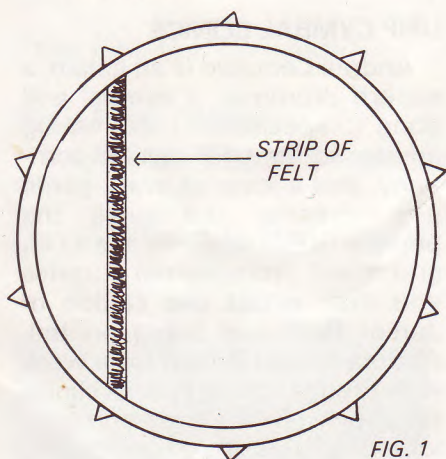

FIG. 1

2. Place a felt pad or moleskin where beater strikes the bass drum (Fig. 2). Add a piece of adhesive tape near the top of the head. Good for double or single head sound. (If double, strip of felt also underneath front head).

Many drummers (Fig. 3) cut a hole in the front head about the size of a 45 rpm record. It is a good compromise between the flat "head off" sound and the "boom" of the two headed sound. It is also excellent for loud playing. Do not place anything (pillow, etc.) inside the two headed drum for best results.

3. Place a blanket or pillow inside the bass drum with the front head off. Blanket or pillow is recommended for recording only.

4. Generally, the bass drum requires the most adjustment (compared to tom toms and snare when performing in a room or hall with bad acoustics).

An external hoop mounted bass drum muffler can be extremely helpful when free-lancing or travelling. It can be adjusted easily and quickly, even between songs. Often this muffler eliminates the need for complete-retuning of the bass drum for each performance. The muffler can be easily positioned for more or less muffling. The spring steel allows for head movement with constant head contact.

Premier's new Black range drumheads, with their sound-controlling patch, are ideal if you find that you need a lot of damping on normal heads. The patch acts as a damper to give the currently-popular 'flat-wet' sound, and you will probably find that no other sort of damping is necessary.

### Did you know that:

Premier was one of the pioneers of plastic drumheads in the late 1950's.

Mahler scored for 24 timpani in one of his symphonies.

Top session drummer Bobby Orr started his professional musical career as a trumpeter.

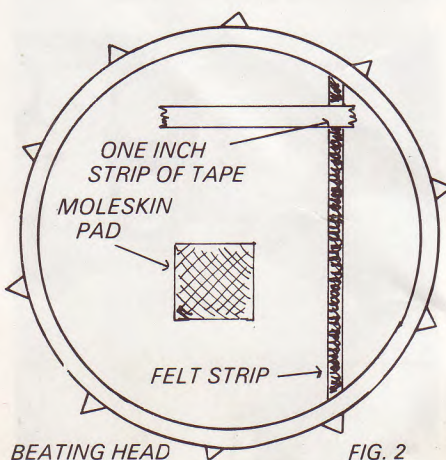

FIG. 2

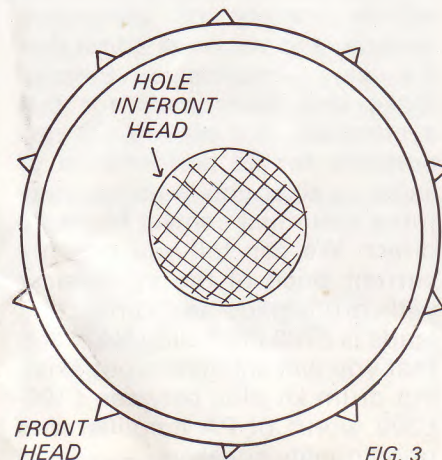

FIG. 3