

# Remo RotoToms

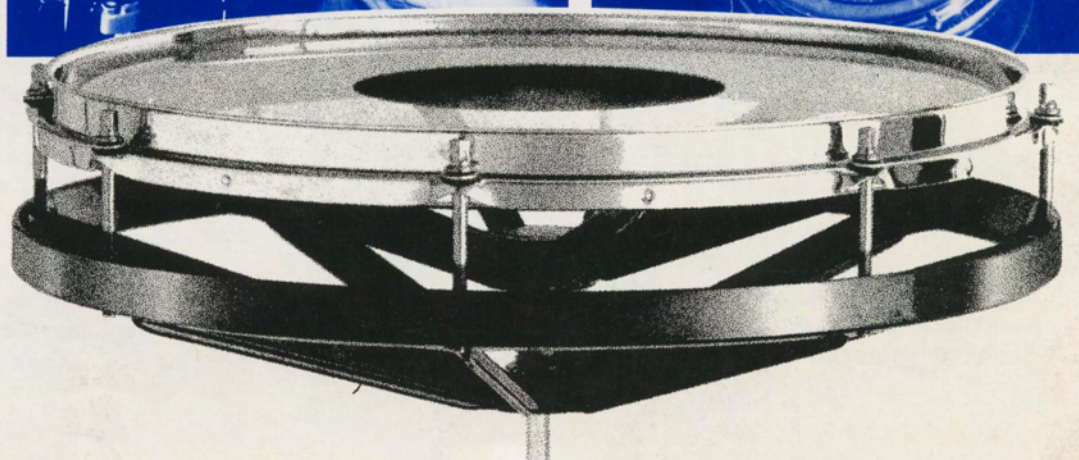
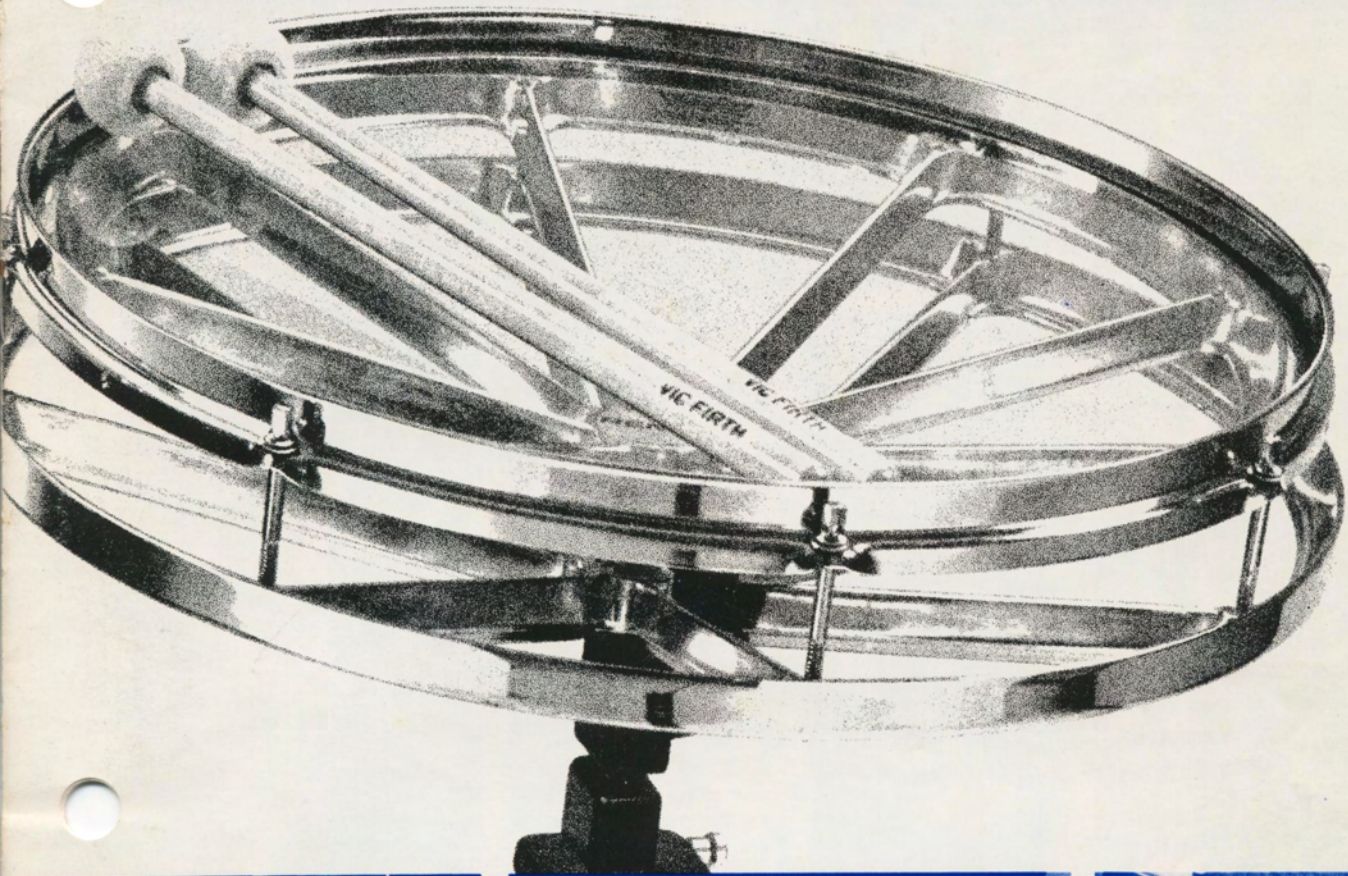

# The Remo RotoTom

The Remo RotoTom defies easy description because of its unique capabilities and incredible versatility. Used with a timpani-type head, it is a definite-pitched instrument with a distinctive, timpani-like sound. Used with a batter head, it can be tuned to produce varied and unusual tom tom effects, ranging from very low to very high pitched sounds. In either mode it can be tuned rapidly over an octave-plus range simply by rotating it on its shaft and even allowing *glissandos*.

Originally conceived by Mr. Al Payson, noted percussionist with the Chicago Symphony, the first RotoToms were created in 1968 for use in performing Michael Colgrass' *Variations for Four Drums and Viola*. From its original concept the RotoTom has evolved into a whole family of percussion instruments which have found application in virtually every musical form.

Rototoms are available in seven sizes—diameters of 6", 8", 10", 12", 14", 16" and 18". Each can be tuned over an extended range of at least an octave, although the practical range for fullness of sound is approximately a sixth interval. A set of seven RotoToms can provide an extended range of about 3½ octaves with a practical, definite-pitched range of 3 octaves. Each size can produce a wide variety of effects, depending upon the drum head used and how it is tuned.

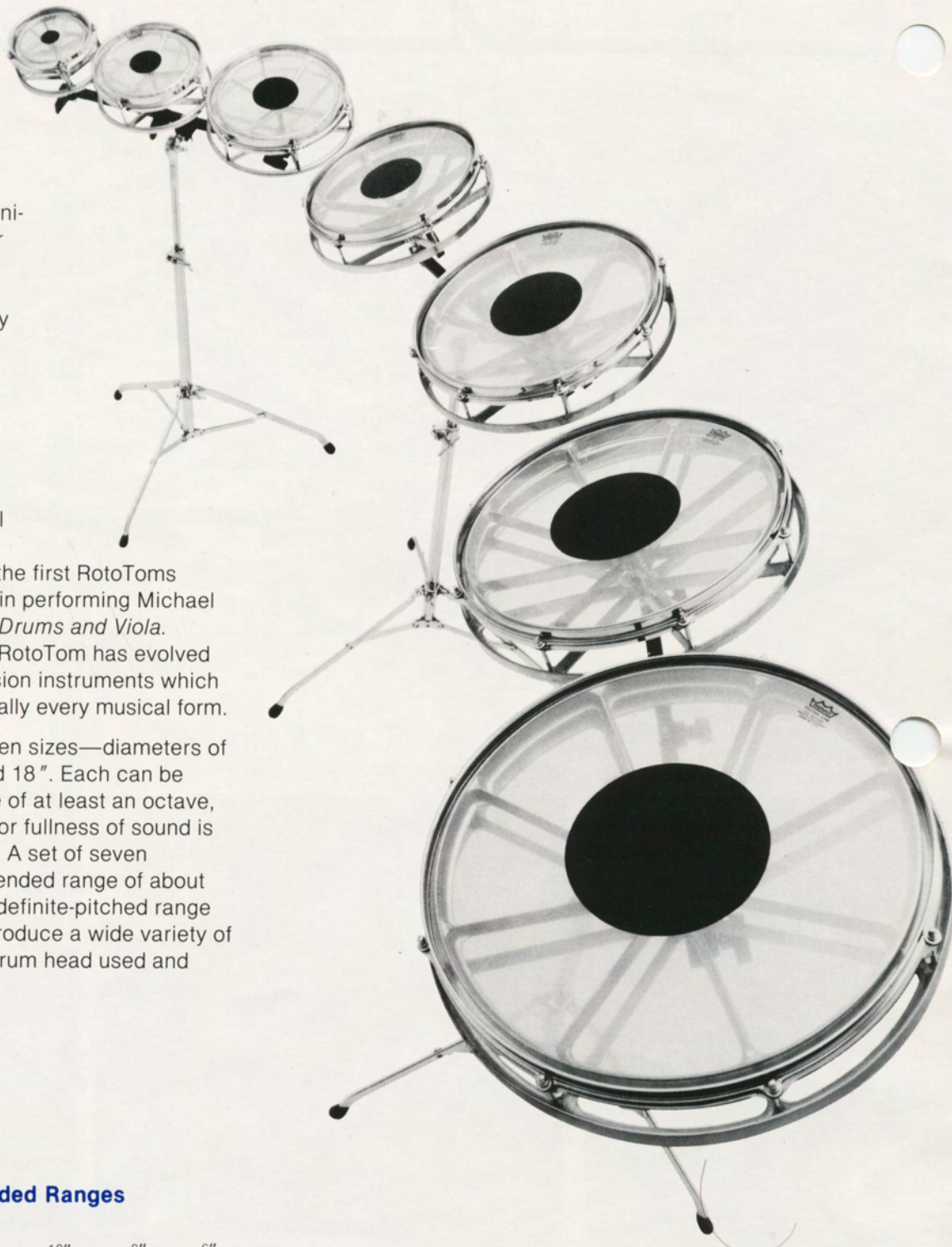

## Typical Practical and Extended Ranges

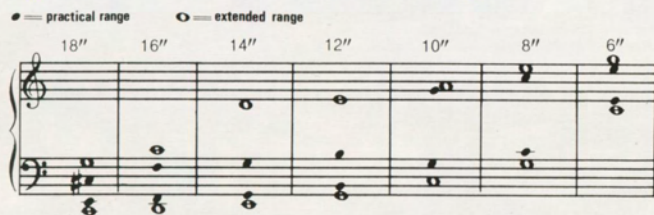

The 3-octave *practical range* indicates where excellent fullness, purity and duration of sound may be expected. The 3½-octave *extended range* may offer additional effects useful in many applications.

# Applications

**Drumset** RotoToms are currently being utilized by outstanding jazz, rock and studio performers both as a new solo voice and as conventional tom toms. CS, PinStripe, FiberSkyn 2 heads—tuned to the mid-range—produce a compact, funky tom tom sound ideal for recording with fewer harmonic overtones than conventional tom toms. Medium weight drum heads are recommended for drumset use. RotoToms can be rapidly tuned to produce *glissandi* effects, and can be arrayed to provide a virtual keyboard of percussion sound. RotoToms have found wide use in recording due to their purity of sound with fewer harmonic overtones than conventional tom toms.

**Marching Percussion/School Music** The versatility of RotoToms offers year-round use in both concert and marching band programs. RotoToms are superior marching timp-toms, combining rapid tuning with lightweight portability and excellent sound quality. The same instruments can function as concert tom toms and as practice timpani. Equipped with batter heads, they then can be used in drumsets for stage bands and jazz ensembles. Their size and portability enables students to take them home easily, while their timpani-like response provides an opportunity to develop techniques far more accurately than with ordinary practice sets.

**Timpani Training** RotoToms and RotoTom Timpanellos are useful in developing proper timpani techniques by students, and even as practice instruments by professional performers. Their portability, storability and relatively low cost make them attractive substitutes when full size timpani are not available. A set of four Timpanellos, which includes rapid tuning pitch pedals, closely approximates the pitch range, response and pedal action of full size timpani. Standard RotoToms with timpani heads permit practice of single stroke rolls at various pitches and are especially useful in ear training.

**Orff/Elementary Music** RotoToms are finding wide acceptance in Orff/Schulwerk method programs and in other elementary music programs where definite-pitched instruments are desired. They offer "professional sound quality," pitch stability unaffected by humidity, and simple, rapid tuning. And their cost is actually much less than many alternative Orff method timpani. A typical RotoTom setup for Orff method programs might include three larger size drums on individual stands, or any two of the three on a twin stand. Smaller RotoToms can be added to provide a complete ensemble.

**General Percussion** RotoToms can be used to take the place of many specialized drums, as well as offering a new voice with unique capabilities. Equipped with batter heads tuned to the mid-range, they are superior indefinite-pitched tom toms. Tuned to the high range, they produce excellent Latin percussion sounds. Equipped with timpani heads, they produce the timbre of timpani but with a distinctive tone. Equipped with Remo's rapid-tuning Pitch Pedal, as in the timpanello instruments, they can duplicate the full range of standard timpani. This versatility and capability for producing innovative percussion effects has led to the widespread use of RotoToms in recording and soundtracks, as well as in percussion ensembles and symphonic music.



Louie Bellson



Casey Scheuerell



Joel Leach



John Beck



## Musical Repertoire

An extensive list of works calling for "tuned drum" or "small tom toms" are performed appropriately on RotoToms, and virtually all timpani literature can be performed on Remo Timpanellos. A growing repertoire of music written expressly for RotoToms now exists, including Michael Colgrass' Pulitzer Prize-winning composition, *Déjà Vu*.

Music for RotoToms available directly from Remo, Inc. includes:

ENCOUNTER VI—William Kraft (E.A.M.). Concertino for RotoToms and percussion quartet.

EPISODE FOR SOLO PERCUSSION—John Beck (Studio 4 Productions). Award-winning multiple percussion solo.

ROTOTOM TECHNIQUE—Vic Firth (Carl Fischer). 26 progressive etudes.

TOCCATA FOR DRUMSET AND ROTOTOM PITCH PEDAL—Steve Traugh (O.A.M.E. Press).

ROTOTOM SOLOS FOR THE MELODIC DRUMMER—Wm. Schinstine (Southern Music).

DIALOGUE—Vic Firth (Carl Fischer). For four timpani, four RotoToms and drum set.

JAZZ WALTZ—Vic Firth (Carl Fischer). For four timpani, four RotoToms and drum set.

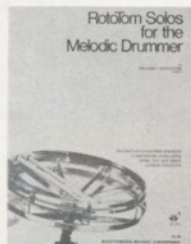
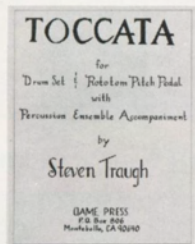
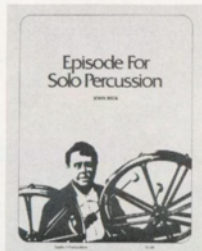
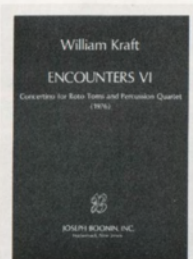

## Drum Heads

RotoToms are furnished with CS Black Dot drum heads as standard, but may be special ordered with the other heads listed below at no extra cost. Each drum head offers distinctive tonal differences which have unique applications with RotoToms.

### CS Black Dot

The special Sound Center reinforcement gives the medium weight CS head outstanding compactness of sound with minimum "over ring" plus great durability. Preferred by rock and jazz performers for drumset use, as well as for general orchestral indefinite-pitched percussion. Furnished in transparent film with black reinforcement.

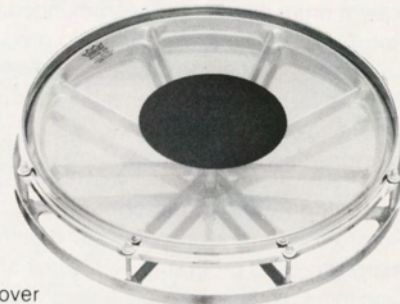

### PinStripe

The two-ply construction with two layers of Emperor-weight film bonded at the collar offers the ultimate in a dampened tom tom sound—"wet, flat and funky" as demanded by today's rock and jazz/rock performers. Rugged, tough-skinned and doubly mellow!

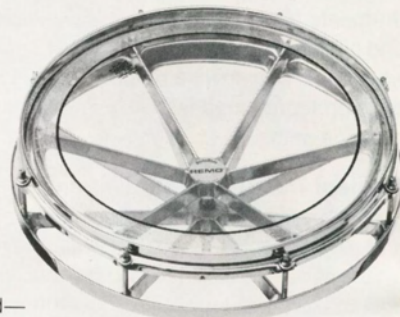

### FiberSkyn 2®

The medium weight FiberSkyn 2 head provides a deeper, more mellow tom tom sound than the CS head. Constructed of an exclusive laminated film, it approaches the appearance, "feel" and sound of high quality calfskin. FiberSkyn 2 heads are recommended for general orchestral and recording use to produce tuned tom tom, bongo and timbale sounds on RotoToms.

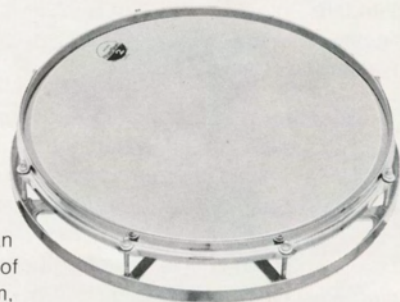

### Timpani

RotoTom timpani heads are specially designed for the instrument to achieve the same purity of sound and consistent performance which have made Remo timpani heads the choice of leading percussionists throughout the world. Furnished in transparent film.

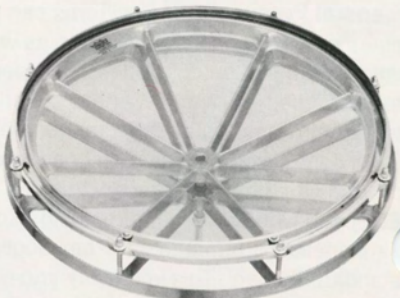

## Trimline Reflectors

The open web design of the RotoTom tends to create directional dispersion of sound perpendicular to the surface of the head. Trimline Reflectors are designed to focus the sound to increase the effective volume of RotoToms. Half Shell Reflectors project sound toward the audience, while Full Shell Reflectors function as a resonating chamber similar to conventional drum shells. Each Trimline Reflector Set consists of a formed clear acrylic Reflector with aluminum rims and mounting hardware, plus a black metal Bracket which attaches to the center rod of the RotoTom. Use of reflectors is recommended for drumset and marching applications, as well as general percussion.

### Half Shell Reflector

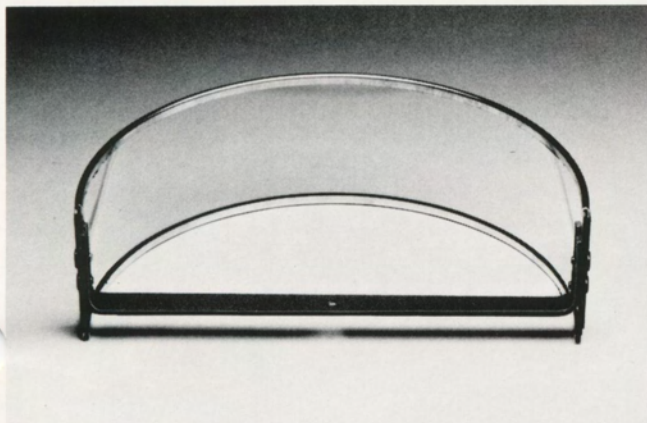

### Full Shell Reflector

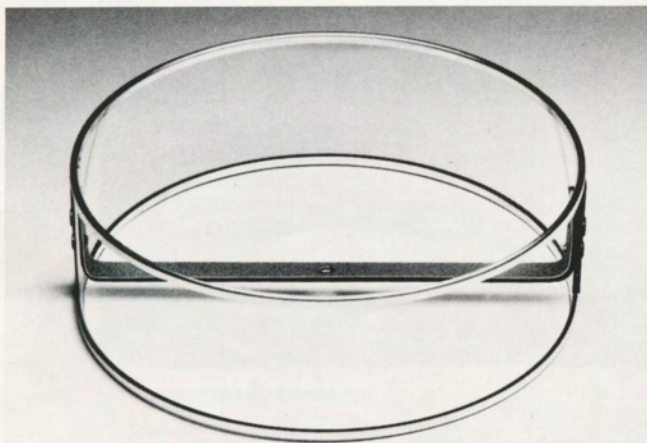

All RotoToms and RotoTom Combination Sets may be ordered with either Half Shell or Full Shell reflectors at extra cost. Trimline Reflectors are also available separately for each RotoTom size.

## Rapid-Tuning Pitch Pedal

The Rapid-Tuning RotoTom Pitch Pedal is a heavy-duty, precision-built pedal/stand that allows the performer to tune any RotoTom instantly over its full range in the same manner as a pedal timpani. It operates by easy toe-and-heel pivot action, and has a built-in Toe Lock which holds any desired pitch. The RotoTom can be manually fine-tuned independent from the pedal, and can be tilted or rotated to virtually any desired playing angle. Two adjustable-height models are available, which fold down compactly for easy transport.

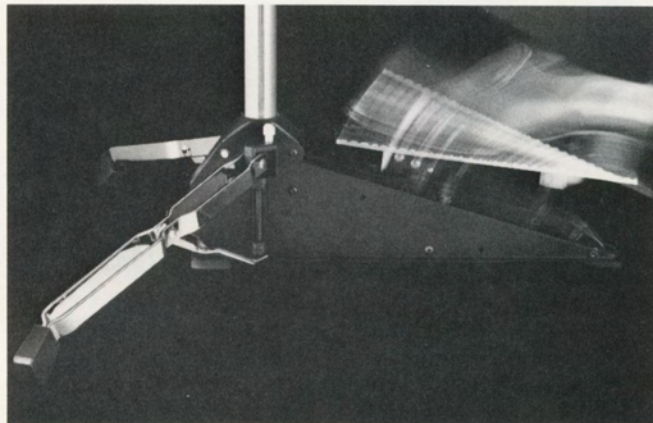

#### Description

High Model	Cat. No.	RP10H
	Part No.	PP-0010-HO
Low Model	Cat. No.	RP10L
	Part No.	PP-0010-LO



## Metal Finishes

RotoToms are furnished in two finishes—chrome-plated and black epoxy coated. The chrome-plated finish is furnished unless otherwise specified. The black epoxy coating provides a durable, attractive finish at lesser cost. Apart from finish, all RotoToms are identical in materials and design, utilizing heavy aluminum castings, plated counterhoop and tension rods and, of course, professional quality Remo drum heads. See "How to Order RotoToms" below.



**Chrome  
Plated**



**Black  
Epoxy  
Coated**

## How to order RotoToms

Specify by **CAT. NO.** as shown in tables for standard chrome finish RotoToms with CS Black Dot drum heads.

### For black epoxy coated RotoToms:

Specify by changing letter prefix from "RR" to "ER".

For marching sets change "MH" prefix to "EMH".

### For alternate drum heads:

Specify by adding suffix to catalog number as follows:

PinStripe—"6"

FiberSkyn 2—"5"

Timpani—"T"

EXAMPLE: To order a black finish 6" RotoTom with PinStripe head, specify Cat. No. ER6-6.

## Single RotoToms

Individual RotoToms in seven sizes are available in three versions: without reflector, with Half Shell Reflector or with Full Shell Reflector. RotoToms are furnished with chrome finish and CS Black Dot drum heads unless otherwise specified. For black finish RotoToms and alternate heads, see "How to Order RotoToms."

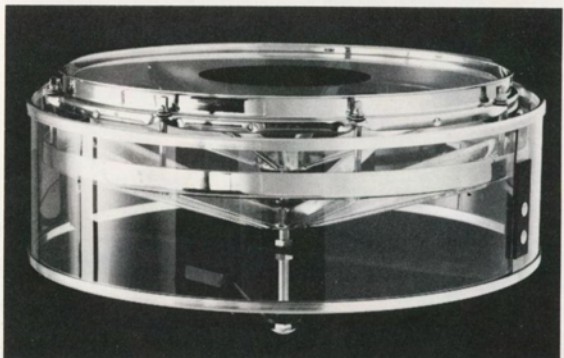
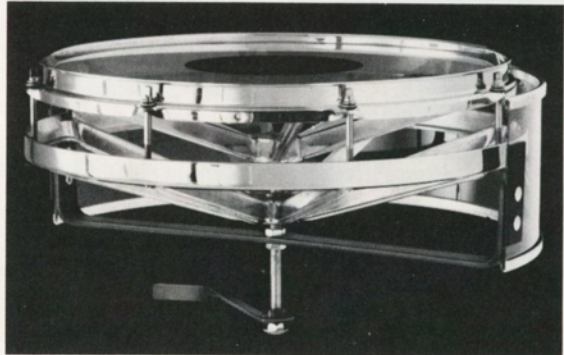
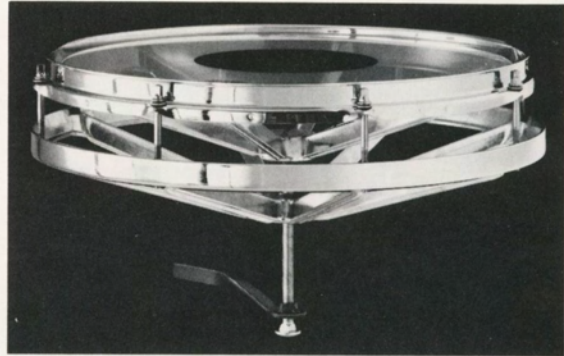

RotoTom Size		Without Reflector	Half Shell Reflector	Full Shell Reflector
6"	<b>Cat. No.</b> Part No.	<b>RR6</b> RR-0006-00	<b>RR6N</b> RR-0006-HO	<b>RR6F</b> RR-0006-FO
8"	<b>Cat. No.</b> Part No.	<b>RR8</b> RR-0008-00	<b>RR8N</b> RR-0008-HO	<b>RR8F</b> RR-0008-FO
10"	<b>Cat. No.</b> Part No.	<b>RR10</b> RR-0010-00	<b>RR10N</b> RR-0010-HO	<b>RR10F</b> RR-0010-FO
12"	<b>Cat. No.</b> Part No.	<b>RR12</b> RR-0012-00	<b>RR12N</b> RR-0012-HO	<b>RR12F</b> RR-0012-FO
14"	<b>Cat. No.</b> Part No.	<b>RR14</b> RR-0014-00	<b>RR14N</b> RR-0014-HO	<b>RR14F</b> RR-0014-FO
16"	<b>Cat. No.</b> Part No.	<b>RR16</b> RR-0016-00	<b>RR16N</b> RR-0016-HO	<b>RR16F</b> RR-0016-FO
18"	<b>Cat. No.</b> Part No.	<b>RR18</b> RR-0018-00	<b>RR18N</b> RR-0018-HO	<b>RR18F</b> RR-0018-FO

# Stand-Mounted Sets

Combination sets of RotoToms with heavy duty adjustable stands are available with and without reflectors, and in choice of drum heads and RotoTom finish. All sets include necessary RotoTrac mounting hardware. Catalog numbers in table are for standard chrome finish RotoToms with CS Black Dot drum heads. For black finish RotoToms and alternate heads, see "How to Order RotoToms" box on page six.

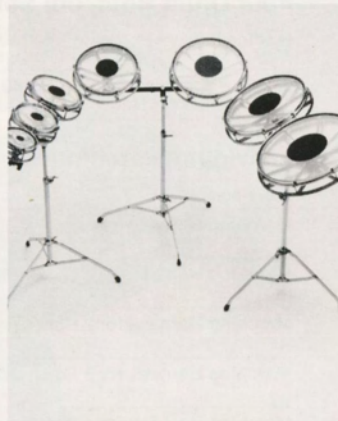

## 2-RotoTom Sets (one 104RT stand included)

RotoTom Sizes		Without Reflectors	Half Shell Reflectors	Full Shell Reflectors
6"-8"	<b>Cat. No.</b> Part No.	<b>RR68</b> RR-0068-00	<b>RR68N</b> RR-0068-HO	<b>RR68F</b> RR-0068-FO
8"-10"	<b>Cat. No.</b> Part No.	<b>RR810</b> RR-0810-00	<b>RR810N</b> RR-0810-HO	<b>RR810F</b> RR-0810-FO
10"-12"	<b>Cat. No.</b> Part No.	<b>RR1012</b> RR-1012-00	<b>RR1012N</b> RR-1012-HO	<b>RR1012F</b> RR-1012-FO
12"-14"	<b>Cat. No.</b> Part No.	<b>RR1214</b> RR-1214-00	<b>RR1214N</b> RR-1214-HO	<b>RR1214F</b> RR-1214-FO
14"-16"	<b>Cat. No.</b> Part No.	<b>RR-1416</b> RR-1416-00	<b>RR-1416N</b> RR-1416-HO	<b>RR1416F</b> RR-1416-FO
16"-18"	<b>Cat. No.</b> Part No.	<b>RR1618</b> RR-1618-00	<b>RR1618N</b> RR-1618-HO	<b>RR1618F</b> RR-1618-FO

## 3-RotoTom Sets (one 104RT stand included)

RotoTom Sizes		Without Reflectors	Half Shell Reflectors	Full Shell Reflectors
6"-8"-10"	<b>Cat. No.</b> Part No.	<b>RR680</b> RR-0680-00	<b>RR680N</b> RR-0680-HO	<b>RR680F</b> RR-0680-FO
8"-10"-12"	<b>Cat. No.</b> Part No.	<b>RR802</b> RR-0802-00	<b>RR802N</b> RR-0802-HO	<b>RR802F</b> RR-0802-FO

## 4-RotoTom Set (one 105RT stand included)

RotoTom Sizes		Without Reflectors	Half Shell Reflectors	Full Shell Reflectors
8"-10"-12"-14"	<b>Cat. No.</b> Part No.	<b>RR8024</b> RR-8024-00	<b>RR8024N</b> RR-8024-HO	<b>RR8024F</b> RR-8024-FO

## 7-RotoTom Set (three 104RT stands included)

RotoTom Sizes		Without Reflectors	Half Shell Reflectors	Full Shell Reflectors
6"-8"-10"-12"-14"-16"-18"	<b>Cat. No.</b> Part No.	<b>RRC7</b> RR-7000-00	<b>RRC7N</b> RR-7000-HO	<b>RRC7F</b> RR-7000-FO

## Individual Stands

Description

Practice Pad Stand	<b>Cat. No.</b> Part No.	<b>101RT</b> ST-1000-00
Lightweight Stand	<b>Cat. No.</b> Part No.	<b>102RT</b> ST-2000-00
Heavy Duty Stand with AD10 and MS4	<b>Cat. No.</b> Part No.	<b>103RT</b> ST-3000-00
Heavy Duty Stand with AD10 and MS24	<b>Cat. No.</b> Part No.	<b>104RT</b> ST-4000-00
Extra Heavy Duty Quad Stand	<b>Cat. No.</b> Part No.	<b>105RT</b> ST-5000-00
Extra Heavy Duty Stand with AD10 and MS4	<b>Cat. No.</b> Part No.	<b>106RT</b> ST-6000-00
Extra Heavy Duty Stand with AD10 and MS24	<b>Cat. No.</b> Part No.	<b>106RT-24</b> ST-6024-00
Extra Heavy Duty Stand with AD10 and MS33	<b>Cat. No.</b> Part No.	<b>106RT-33</b> ST-6033-00

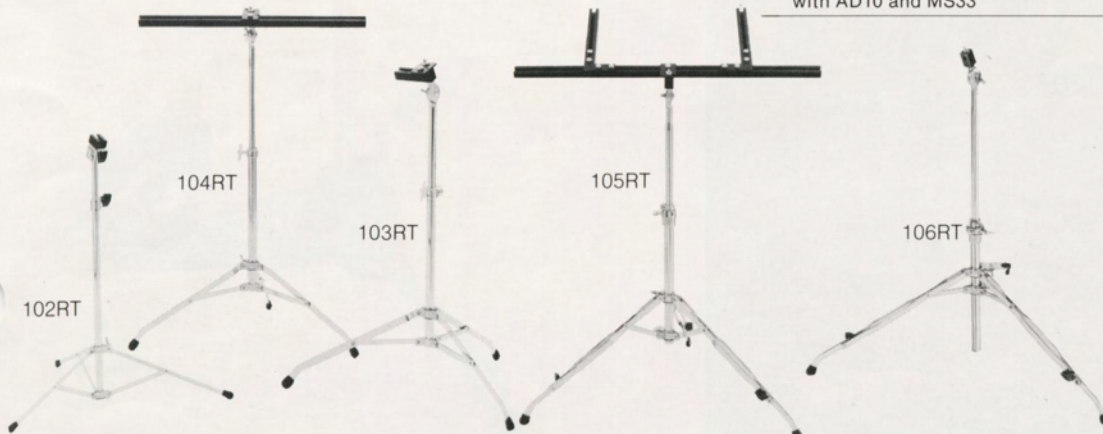

# Marching Sets

Offered in sets including marching harness with from one to four RotoToms plus RotoTrac mounting hardware, with or without reflectors. Catalog numbers below are for chrome finish with CS Black Dot drum heads. To order black finish RotoToms and alternate drum heads, see "How to Order RotoToms" box on page six.

## Single RotoToms

RotoTom Sizes		Without Reflectors	Half Shell Reflectors	Full Shell Reflectors
18"	<b>Cat. No.</b> Part No.	<b>MH10A</b> MH-1018-00	<b>MH10AN</b> MH-1018-HO	<b>MH10AF</b> MH-1018-FO
16"	<b>Cat. No.</b> Part No.	<b>MH10B</b> MH-1016-00	<b>MH10BN</b> MH-1016-HO	<b>MH10BF</b> MH-1016-FO
14"	<b>Cat. No.</b> Part No.	<b>MH10C</b> MH-1014-00	<b>MH10CN</b> MH-1014-HO	<b>MH10CF</b> MH-1014-FO

## Two Drum RotoTom Sets

RotoTom Sizes		Without Reflectors	Half Shell Reflectors	Full Shell Reflectors
16"-18"	<b>Cat. No.</b> Part No.	<b>MH20A</b> MH-2018-00	<b>MH20AN</b> MH-2018-HO	<b>MH20AF</b> MH-2018-FO
14"-16"	<b>Cat. No.</b> Part No.	<b>MH20B</b> MH-2016-00	<b>MH20BN</b> MH-2016-HO	<b>MH20BF</b> MH-2016-FO
12"-14"	<b>Cat. No.</b> Part No.	<b>MH20C</b> MH-2014-00	<b>MH20CN</b> MH-2014-HO	<b>MH20CF</b> MH-2014-FO

## Three Drum RotoTom Sets

RotoTom Sizes		Without Reflectors	Half Shell Reflectors	Full Shell Reflectors
14"-16"-18"	<b>Cat. No.</b> Part No.	<b>MH30A</b> MH-3018-00	<b>MH30AN</b> MH-3018-HO	<b>MH30AF</b> MH-3018-FO
12"-14"-16"	<b>Cat. No.</b> Part No.	<b>MH30B</b> MH-3016-00	<b>MH30BN</b> MH-3016-HO	<b>MH30BF</b> MH-3016-FO
10"-12"-14"	<b>Cat. No.</b> Part No.	<b>MH30C</b> MH-3014-00	<b>MH30CN</b> MH-3014-HO	<b>MH30CF</b> MH-3014-FO

## Four Drum RotoTom Set

RotoTom Sizes		Without Reflectors	Half Shell Reflectors	Full Shell Reflectors
8"-10"-12"-14"	<b>Cat. No.</b> Part No.	<b>MH40</b> MH-4014-00	<b>MH40AN</b> MH-4014-HO	<b>MH40AF</b> MH-4014-FO

## Individual Marching Harnesses

Description	Cat. No.	Part No.
Marching Harness Only	<b>MHO</b>	MH-0000-00
Marching Harness for Single RotoTom	<b>MH1</b>	MH-1000-00
Marching Harness for 2 RotoToms	<b>MH2</b>	MH-2000-00
Marching Harness for 3 RotoToms	<b>MH3</b>	MH-3000-00
Marching Harness for 4 RotoToms	<b>MH4</b>	MH-4000-00

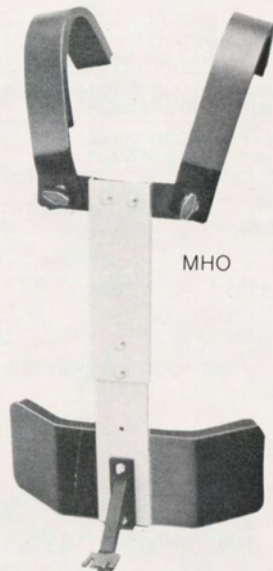



# Timpanello

The Timpanello represents the logical extension of the Remo RotoTom principle into a professional-quality instrument with timpani-like sound and performing characteristics. Each Timpanello consists of a RotoTom equipped with a definite-pitch timpani head and a special coppertone half-shell reflector, mounted on a Rapid-Tuning Pitch Pedal. A set of four Timpanellos (12"-14"-16"-18") can duplicate the entire range of full-sized pedal timpani. The Pitch Pedal (see page 5) provides instant tuning capability of the RotoTom over its entire range, and affords operating ease comparable to standard pedal timpani.

Thus, the Timpanello can be used both to augment full-sized timpani (as in percussion ensembles) and to substitute for full-size timpani in general percussion applications, where its compactness, portability and relative low cost offer attractive advantages. In addition, the Timpanello is particularly useful in demonstrating and practicing timpani technique on both student and professional levels.

#### RotoTom Size

12"	Cat. No.	TP-2012-00
14"	Cat. No.	TP-2014-00
16"	Cat. No.	TP-2016-00
18"	Cat. No.	TP-2018-00



Vic Firth



# RotoTrac Mounting System

Remo's unique RotoTrac Modular Mounting System permits percussionists to create their own RotoTom setups for use with Remo stands or marching harnesses—simply and quickly. It consists of four slotted mounting tracks of strong extruded aluminum—from 4" to 33" in length—plus the common 3/8" carriage bolt and a variety of connectors and adapters used as mounting hardware. Other track lengths are available by special order.

Any setup can be removed and remounted in the same position time after time—with no variation in spacing or angle. RotoToms can be securely positioned at any point in the tracks simply by tightening a lever. 55° and 90° angle track-to-track connectors permit a wide variety of setups (see suggested combinations on this page). All RotoToms are now furnished with a convenient Locking Lever to facilitate attachment to Track or Adapter. The RotoTrac system fits all Remo stands and MHO Marching Harness.

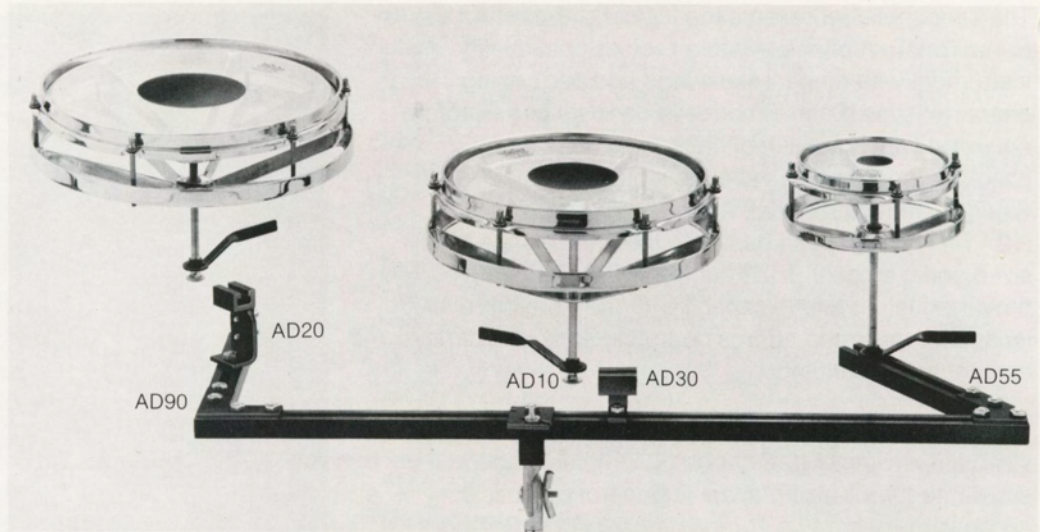
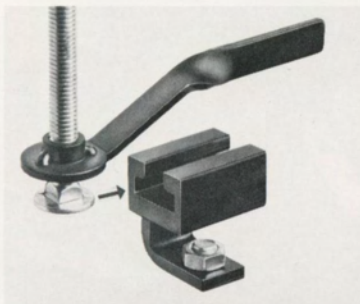

## RotoTom Adapters



**AD30**  
Positions, swivels and offers quick disconnect.

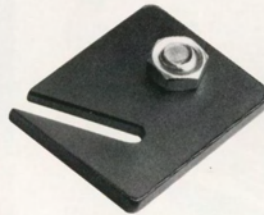

**AD10 STAND ADAPTER**  
Accepts track. Angled slot permits crossway or front-to-back mounting. (Included with 103RT and 104RT stands).



**AD20**  
Positions, swivels and tilts. Quick disconnect feature.

## Track

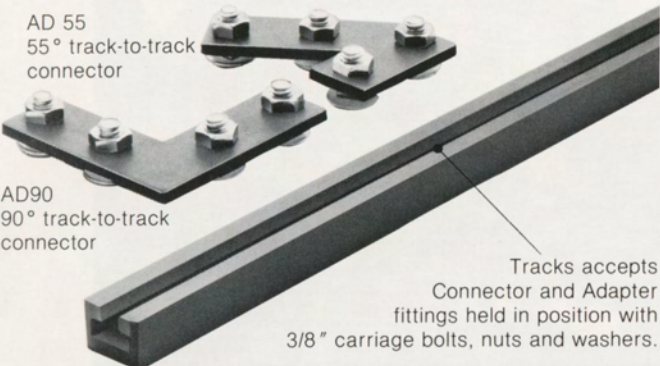
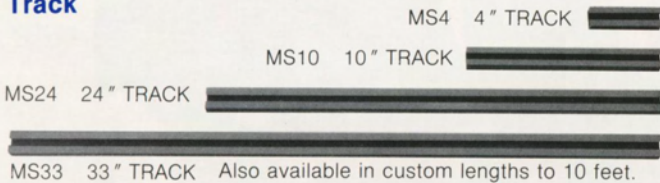

## Suggested Setups

Shown below are typical setups which can be accomplished with the RotoTrac system. The size and weight of the RotoToms should be taken into account in planning any setup. Stands are available for two-, three- and four-drum setups.

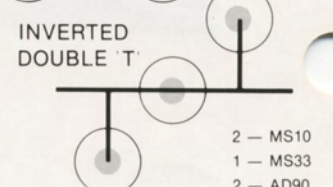
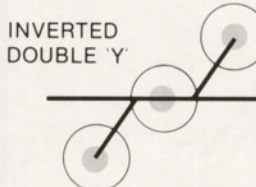
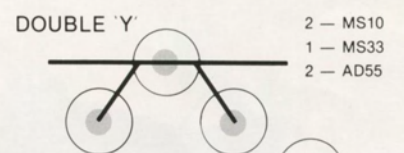
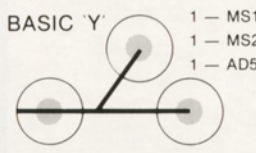
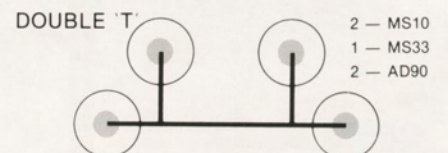
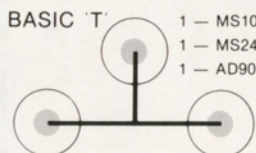

# Cases and Covers

## Cases for RotoToms and Pitch Pedals

These heavy-duty shipping cases are formed of chemically hardened black fiberboard with reinforced sides, lids and bottoms. They are fully lined with protective 1/2" foam rubber.

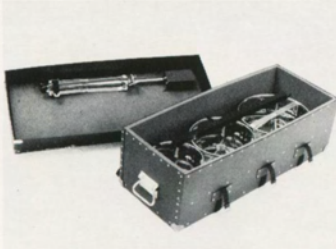

**CA-3** Accommodates one assembled RR680N or RR680F RotoTom set consisting of 6", 8" and 10" RotoToms plus half or full shell reflectors and fold-up stand. Has three carrying handles, nylon webbed straps and metal-reinforced corners. Measures 35" x 14 1/2" x 10 1/2". 19 lbs.



**CA-2** Accommodates a wide range of 2-, 3- and 4-drum combinations of RotoToms with half or full shell reflectors plus stands. Includes reinforced wooden divider, separate tray for stands, RotoTrac mounting hardware and accessories. Equipped with top and side trunk handles, heavy-duty straps and metal edges and corners. Measures 24" x 15" x 26". 20 lbs.



**CA-4** Holds one RP10L Pitch Pedal. Has metal-reinforced corners, single handle and two nylon straps. Measures 4"H x 10"W x 21"L.

**CA-5** Identical to CA-4, except it is built to accommodate one RP10H Pitch Pedal. Measures 4"H x 10"W x 29"L.

## RotoTom Vinyl Covers

Heavy-duty textured vinyl covers are water resistant with protective fuzzy-backed interior. Double-stitched wraparound handle, nylon drawstring. Available in 8 sizes—one for each size RotoTom plus an added size for convenience of percussionists who want to encase Half or Full Shell Reflectors with their RotoToms. This requires using a cover one size larger than the RotoTom.

Cat. No. Part No.	CV-6 CV-0006-00	For Use With	
		RotoTom only	RotoTom with Reflector
		RR6	---
		RR8	RR6N
		RR10	RR8N
		RR12	RR10N
		RR14	RR12N
		RR16	RR14N
		RR18	RR16N
		---	RR18N

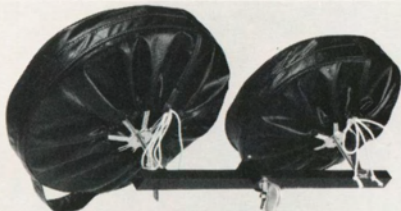

# Replacement Parts

## RotoTrac Components

Description	Cat. No. Part No.	AD100 AD-0100-00
Universal Adapter		
Stand Adapter		
Swivel-and-Tilt Connector (RotoTom to track)		
Fixed Position Connector (RotoTom to track)		
90° Angle Track-to-Track Connector		
55° Angle Track-to-Track Connector		
4-inch Track		
10-inch Track		
24-inch Track		
33-inch Track		

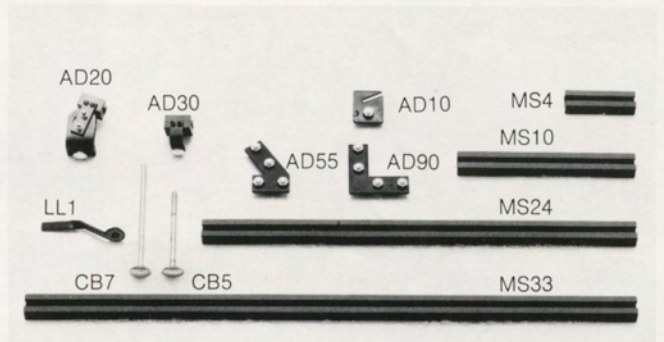

## Replacement Heads

Size	CS BlackDot	PinStripe	FiberSky 2	Timpani
6"	Cat. No. R306-1 Part No. CS-0306-10	P306BE PS-0306-00	X506M FM-0506-00	306T TI-0306-00
8"	Cat. No. R308-1 Part No. CS-0308-10	P308BE PS-0308-00	X508M FM-0508-00	308T TI-0308-00
10"	Cat. No. R310-1 Part No. CS-0310-10	P310BE PS-0310-00	X510M FM-0510-00	310T TI-0310-00
12"	Cat. No. R312-1 Part No. CS-0312-10	P312BE PS-0312-00	X512M FM-0512-00	312T TI-0312-00
14"	Cat. No. R314-1 Part No. CS-0314-10	P314BE PS-0314-00	X514M FM-0514-00	314T TI-0314-00
16"	Cat. No. R316-1 Part No. CS-0316-10	P316BE PS-0316-00	X516M FM-0516-00	316T TI-0316-00
18"	Cat. No. R318-1 Part No. CS-0318-10	P318BE PS-0318-00	X518M FM-0518-00	318T TI-0318-00

## Universal Adapter

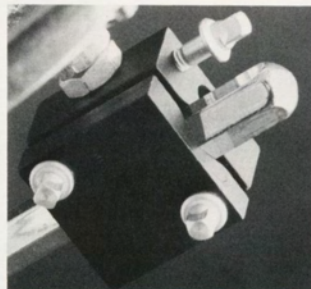

Fits many different types of stands and tom-tom holders. Clamps on rods from 1/4" to 5/8" or larger. CAT. NO. AD100

## Remo RotoToms: Choice of leading percussion performers

In virtually every field of percussion the versatility and unique rapid-tuning capability of RotoToms have found acceptance and use by outstanding percussionists, composers and musical groups of all kinds. Shown here are just a few:



Billy Cobham



William Kraft



Bill Bruford



Bev Bevan



Long Island Sunrisers



Arthur Press

# REMO<sup>®</sup> USA

Remo, Inc. 12804 Raymer Street,  
North Hollywood, California 91605  
(213) 983-2600



Steve Smith