

Rogers

CATALOG 62R

**DRUMS
WITH
SWIV-O-MATIC**

ROGERS DRUMS, CLEVELAND 15, OHIO

BUDDY RICH



Famous INTERNATIONAL STARS
... Play **ROGERS**



CHAS. BOTTERILL
ENGLAND



MARK BOWDEN
AUSTRALIA



H. SHIRAKI
JAPAN

Rogers ...

a great new name in drums ... offering professional and school musicians snappier sound, quicker response, longer trouble-free life ... *FEATURING* names that set the standard in the drum world ...

DYNA-SONIC ... HOLIDAY ... YORKTOWN
CAMBRIDGE ... LUXOR ... CONCORD

ROGERS PEARL AND LACQUER FINISHES



BLUE ONYX PEARL



BLACK ONYX PEARL



WHITE MARINE PEARL



BLACK DIAMOND PEARL



MARDI GRAS PEARL



SOLID JET BLACK PEARL



SPARKLING GOLD PEARL



SPARKLING RED PEARL



SPARKLING BLUE PEARL



SPARKLING SILVER PEARL



SPARKLING GREEN PEARL



WINE-RED RIPPLE PEARL



STEEL-GRAY
RIPPLE PEARL

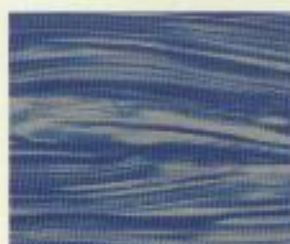

SKY-BLUE
RIPPLE PEARL



BLACK AND GOLD
MULTI-COLOR



BLUE AND SILVER
MULTI-COLOR

SWIV-O-MATIC® the amazing new advance in drum attachments. Drums and cymbals *stay put* at any playable height or angle ... instant set-up, adjustment, take-down.

SOLD THE WORLD OVER ...

U. S. Distributor: Jos. Rogers Incorporated, Cleveland, Ohio
British Commonwealth: Boosey and Hawkes, London, England

ROGERS SOLD THROUGH DEALERS IN OPEN TERRITORIES ONLY

Swiv-O-Matic

DRUM EQUIPMENT

SHELL MOUNT AND HOOP MOUNT MODELS

FEATURES...

- ★ **ALL-DIRECTIONAL**
Ball and socket construction permits positioning to any playable height or angle.
- ★ **INTERCHANGEABLE**
Permits switching of tom-tom, cymbals, etc. from one location to another.
- ★ **FAST SET-UP**
Standard drum key is all that's needed for fast set-up or knock-down. No special tools required.
- ★ **WISE-LIKE GRIP**
Specially designed collet unit provides positive, secure locking.
- ★ **HEX SHAFTS**
Prevent turning and provide strength and elegance.
- ★ **HIGH GRADE STEEL**
All parts are fabricated from high grade steel.
- ★ **DELUXE CHROME PLATED**
All SWIV-O-MATIC units are highly polished and Deluxe Chrome-plated to sparkling brilliance.
- ★ **FITS ALL DRUMS**
Designed to fit all makes and models.

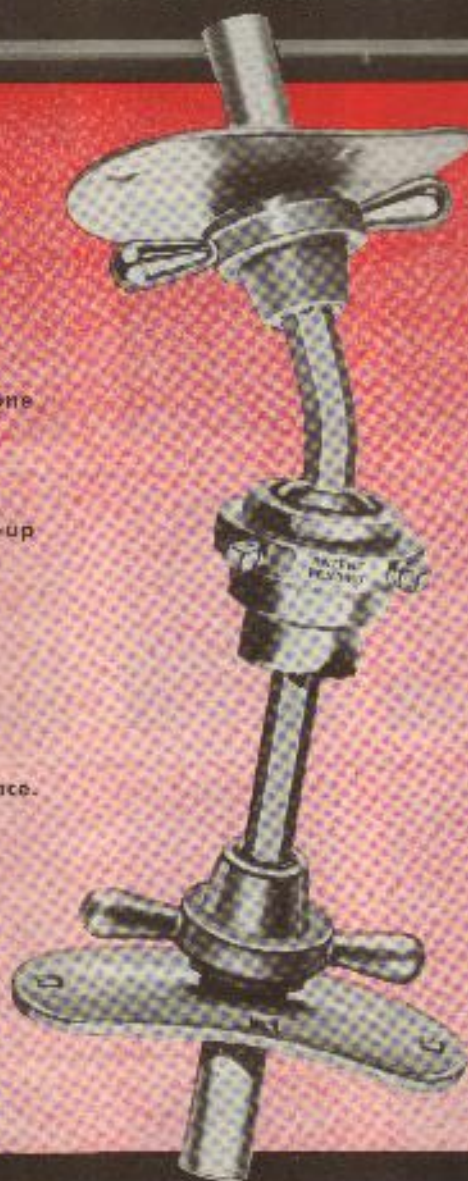

Swiv-O-Matic

- HI-HAT STANDS
- SNARE DRUM STANDS
- CYMBAL STANDS
- TOM TOM HOLDERS
- CYMBAL HOLDERS
- CYMBAL TILTERS
- CYMBAL EXTENSION ARMS
- SPURS • PEDAL
- SNARE DRUM HOLDER
- LEG REST
- STRAINER



SWIV-O-MATIC drum attachments...new freedom for drummers

Set 'em up once and **THEY STAY PUT**, for an evening or a year!



PLAY 'EM



MOVE 'EM



PLAY 'EM

... MORE and MORE DRUMMERS



DAVE ALPERT



ART ANTON



DICK BARNETT



TONY BELLSON



DAVE BLACK



HAL BLAINE



ROY BROOKS



HOWARD BRUSH



DAMON BUCKLEY



ROY BURNS



FRANK CAPP



JIM CHAPIN



JOHN DeSOTO



FRANK DEVITO



PAUL EDWARDS



MOREY FELD



FRANK FLYNN



JERRY FRIEDMAN



LIONEL HAMPTON



J. C. HEARD



MURRAY HARMON



LOUIS HAYES



ALBERT HEATH



MILT HOLLAND



STAN LAWRENCE



SABBY LEWIS



DON LILLO



CHET LUTY



LOU MALIN



FREDDIE MANTONI



BOB NEEL



GRASELLA OLIPHANT



HOWIE OLIVER



EARL PALMER



PAT PATTON



BEY PERRY



WALT SAGE



MICKY SHEEN



ANGELO SICONOLFI



JOSIE STALCUP



JOE TESTA



GENE THALER

are PLAYING ROGERS . . .



EDDIE "HOLE" BOURNE



CHAS. CAMERON



DANNY BRIDGE



JACK BROKENSHA



EDDY COLE



FRANKIE CHAVEZ



MONA CLARK



DAVE COLDREN



RUDY COLLINS



IRV COTTLER



JOE CUSATIS



ERNE GAZZOS



JERRY GILGOR



JAMES GIRONE



RONNIE GREB



SOL GUBIN



GUS GUSTOFSON



FRANK IPPOLITTO



JIMMY JOHNSON



FRANK GAGLIARDI



STAN KRELL



CHUCK LAMPKIN



DENNIS LEPRON



JACK MCCARTNEY



GERRY MEANEY



BARRY MILES



AL MONTE



LLOYD MORALES



"WEEDY" MORRIS



CHAS. PERRY



CARL PETTICA



RAY PRICE



JOE RAYNOR



CHET RICORD



GERRY ROSEN



HORTER THOMPSON



RAY TUCKER



JACK VOLK



HAROLD WALLACE



DENNIS WILSON



LEE YOUNG

ROGERS "BUDDY RICH"



Buddy Rich "THREE-STAR"

IN RADIANT PEARL AND DELUXE CHROME
PLASTIC HEADS, UNLESS OTHERWISE SPECIFIED

No. 1810 - OUTFIT

Total List Value \$415.70
AS ILLUSTRATED
Specify Choice of Pearl

WITHOUT CYMBALS

\$402⁵⁰

TAX
PAID

INCLUDES THESE DRUMS AND ACCESSORIES:

- 1—No. 87—HOLIDAY 14 x 20 BASS DRUM, choice of pearl \$136.00
- 1—No. 25—HOLIDAY 5 x 14 SNARE DRUM, choice of pearl 99.00
- 1—No. 51—HOLIDAY 8 x 12 TOM TOM, choice of pearl 74.00

No. 1811 - OUTFIT

Total List Value, \$427.20
AS ILLUSTRATED, BUT IN
THIS COMBINATION OF SIZES:

WITHOUT CYMBALS

\$415⁰⁰

TAX
PAID

- 1—No. 91—HOLIDAY 14 x 22 BASS DRUM, choice of pearl \$145.00
- 1—No. 25—HOLIDAY 5 x 14 SNARE DRUM, choice of pearl 99.00
- 1—No. 53—HOLIDAY 9 x 13 TOM TOM, choice of pearl 76.50

FOR DYNA-SONIC SNARE DRUM, ADD \$50.00

CYMBALS FOR "3-STAR" OUTFITS

- No. 4330M—"AYEDIS ZILDJIAN" CYMBAL, 18" Medium \$ 44.00B
- No. 4267—"PASHA" CYMBAL, 18" Medium 31.50

See Listing on Cymbal Pages for Other Sizes.

ACCESSORIES FOR "THREE-STAR" OUTFITS NOS. 1810 . . . 1811

- 1—No. 361R—SWIV-O-MATIC Tom Tom Holder, chrome \$ 19.75
- 1—No. 252R—KNOBBY Telescopic Cymbal Holder, chrome 13.50
- 1 pr. Internal Spurs, chrome—No. 338R for 20"—No. 340R for 22" 10.95
- 1—SWIV-O-MATIC Foot Pedal, specify choice 39.50
- No. 395R (solid footboard) or No. 396R (hinged footboard)
- 1—No. 1718C—Buck Rogers Drum Stand, chrome 19.75
- 1 pr. No. BR—Buddy Rich Drum Sticks 1.50
- 1 pr. No. 940R—Buddy Rich Wire Brushes 1.75

Buddy Rich "HEADLINER"

IN RADIANT PEARL AND DELUXE CHROME
PLASTIC HEADS, UNLESS OTHERWISE SPECIFIED

No. 1805 - OUTFIT

Total List Value \$544.20
AS ILLUSTRATED
Specify Choice of Pearl

WITHOUT CYMBALS

\$527⁵⁰

TAX
PAID

INCLUDES THESE DRUMS AND ACCESSORIES:

- 1—No. 87—HOLIDAY 14 x 20 BASS DRUM, choice of pearl \$136.00
- 1—No. 25—HOLIDAY 5 x 14 SNARE DRUM, choice of pearl 99.00
- 1—No. 51—HOLIDAY 8 x 12 TOM TOM, choice of pearl 74.00
- 1—No. 55—HOLIDAY 14 x 14 TOM TOM, choice of pearl 88.50

No. 1806 - OUTFIT

Total List Value \$551.70
AS ILLUSTRATED, BUT IN
THIS COMBINATION OF SIZES:

WITHOUT CYMBALS

\$535⁰⁰

TAX
PAID

- 1—No. 87—HOLIDAY 14 x 20 BASS DRUM, choice of pearl \$136.00
- 1—No. 25—HOLIDAY 5 x 14 SNARE DRUM, choice of pearl 99.00
- 1—No. 51—HOLIDAY 8 x 12 TOM TOM, choice of pearl 74.00
- 1—No. 59—HOLIDAY 16 x 16 TOM TOM, choice of pearl 96.00

No. 1807 - OUTFIT

Total List Value \$563.20
AS ILLUSTRATED, BUT IN
THIS COMBINATION OF SIZES:

WITHOUT CYMBALS

\$545⁰⁰

TAX
PAID

- 1—No. 91—HOLIDAY 14 x 22 BASS DRUM, choice of pearl \$145.00
- 1—No. 25—HOLIDAY 5 x 14 SNARE DRUM, choice of pearl 99.00
- 1—No. 53—HOLIDAY 9 x 13 TOM TOM, choice of pearl 76.50
- 1—No. 59—HOLIDAY 16 x 16 TOM TOM, choice of pearl 96.00

FOR DYNA-SONIC SNARE DRUM, ADD \$50.00



ACCESSORIES FOR "HEADLINER" OUTFITS NOS. 1805 . . . 1806 . . . 1807

- 1—No. 361R—SWIV-O-MATIC Tom Tom Holder, chrome \$ 19.75
- 1—No. 252R—KNOBBY Telescopic Cymbal Holder, chrome 13.50
- 1—SWIV-O-MATIC Foot Pedal, Specify choice 39.50
- No. 395R (solid footboard) or No. 396R (hinged footboard)
- 1 pr. Internal Spurs, chrome—No. 338R for 20"—No. 340R for 22" 10.95
- 1 Set KNOBBY Tom Tom Legs, Chrome No. 275R for 16"—No. 276R for 14" 22.50
- 1—No. 503C—Hi-Hat Sock Pedal, chrome 17.50
- 1—No. 1718C—Buck Rogers Drum Stand, chrome 19.75
- 1 pr. No. BR—Buddy Rich Drum Sticks 1.50
- 1 pr. No. 943RC—Buddy Rich Wire Brushes 1.75

CYMBALS FOR "HEADLINER" OUTFITS

No. 4353 "AYEDIS ZILDJIAN" CYMBAL ASSORTMENT **\$114^{40B}**

TAX
PAID

- No. 4340M—(2) 14 in. Hi-Hat, Medium, @ \$29.70B \$ 59.40B
- No. 4332M—(1) 20 in. Medium 55.00B

No. 4309 "PASHA" CYMBAL ASSORTMENT **\$72⁵⁰**

TAX
PAID

- No. 4265—(2) 14 in. Hi-Hat, Medium, @ \$15.75 \$ 31.50
- No. 4268—(1) 20 in. Medium 41.00

See Listing on Cymbal Pages for Other Sizes

OUTFITS WITH Swiv-O-Matic



Buddy Rich

Regarded by many drummers as the greatest technician jazz drumming has ever known. He worked as a single at 4, and toured the Tivoli circuit at 7. Buddy started playing jazz professionally in 1936, with Joe Marsala's band at the Hickory House in New York.

He played with many great bands of the swing era and was featured in several "Jazz of the Philharmonic" tours and has the distinction of being the highest paid sideman in the history of jazz. The incomparable Buddy Rich commands the respect and admiration of drummers the world over.

NOTE:

Buddy Rich uses this same outfit plus another 16" x 16" Floor Tom-Tom.



Buddy Rich "CELEBRITY"

WITH NEW "DYNA-SONIC" SNARE DRUM

IN RADIANT PEARL AND DELUXE CHROME — PLASTIC HEADS, UNLESS OTHERWISE SPECIFIED

No. 1802 - OUTFIT

Total List Value \$647.60
AS ILLUSTRATED
Specify Choice of Pearl

WITHOUT CYMBALS

\$627⁵⁰
TAX PAID

INCLUDES THESE DRUMS AND ACCESSORIES:

- 1—DYNA-SONIC 5 x 14 SNARE DRUM, Specify choice \$150.00
No. 32 (Choice of Pearl) or No. 36 (Metal Shell)
- 1—No. 91—HOLIDAY 14 x 22 BASS DRUM, choice of pearl ... 145.00
- 1—No. 53—HOLIDAY 9 x 13 TOM TOM, choice of pearl 76.50
- 1—No. 59—HOLIDAY 16 x 16 TOM TOM, choice of pearl 96.00

No. 1801 - OUTFIT

Total List Value \$636.10

AS ILLUSTRATED, BUT IN THIS COMBINATION OF SIZES:

WITHOUT CYMBALS

\$617⁵⁰
TAX PAID

- 1—DYNA-SONIC 5 x 14 SNARE DRUM, Specify choice \$150.00
No. 32 (Choice of Pearl) or No. 36 (Metal Shell)
- 1—No. 87—HOLIDAY 14 x 20 BASS DRUM, choice of pearl 136.00
- 1—No. 51—HOLIDAY 8 x 12 TOM TOM, choice of pearl 74.00
- 1—No. 59—HOLIDAY 16 x 16 TOM TOM, choice of pearl 96.00

No. 1800 - OUTFIT

Total List Value \$628.60

AS ILLUSTRATED, BUT IN THIS COMBINATION OF SIZES:

WITHOUT CYMBALS

\$610⁰⁰
TAX PAID

- 1—DYNA-SONIC 5 x 14 SNARE DRUM, Specify choice \$150.00
No. 32 (Choice of Pearl) or No. 36 (Metal Shell)
- 1—No. 87—HOLIDAY 14 x 20 BASS DRUM, choice of pearl 136.00
- 1—No. 51—HOLIDAY 8 x 12 TOM TOM, choice of pearl 74.00
- 1—No. 55—HOLIDAY 14 x 14 TOM TOM, choice of pearl 88.50

ACCESSORIES FOR "CELEBRITY" OUTFITS NOS. 1800 . . . 1801 . . . 1802

- 1—No. 360R—SWIV-O-MATIC Tom Tom Holder, chrome \$ 19.75
- 2—No. 252R—KNOBBY Telescopic Cymbal Holders, chrome @ \$13.50 27.00
- 1 Set KNOBBY Tom Tom Legs, Chrome No. 275R for 16" — No. 276R for 14" 22.50
- 1 pr. Internal Spurs, chrome—No. 340R for 22"—No. 338R for 20" 10.95
- 1—SWIV-O-MATIC Foot Pedal, Specify choice 39.50
No. 395R (solid footboard) or No. 396R (hinged footboard)
- 2—No. 1725C—Floor Cymbal Stands, chrome, @ \$9.95 19.90
- 1—No. 503C—Hi-Hat Sock Pedal, chrome 17.50
- 1—No. 1718C—Buck Rogers Drum Stand, chrome 19.75
- 1 pr. No. BR—Buddy Rich Drum Sticks 1.50
- 1 pr. No. 940R—Buddy Rich Wire Brushes 1.75

CYMBALS FOR "CELEBRITY" OUTFITS

No. 4308 "AYEDIS ZILDJIAN" CYMBAL ASSORTMENT **\$214^{50B}**

- No. 4320—(1) 8 in. Paper Thin \$ 8.00
- No. 4340M—(2) 14 in. Hi-Hat, Medium, @ \$29.70B 59.40B
- No. 4328M—(1) 16 in. Medium 36.30B
- No. 4330M—(1) 18 in. Medium 44.00B
- No. 4334M—(1) 22 in. Medium 66.00B

No. 4352 "PASHA" CYMBAL ASSORTMENT **\$154⁵⁰**

- No. 4301—(1) 10 in. Paper Thin \$ 6.00
- No. 4265—(2) 14 in. Hi-Hat, Medium, @ \$15.75 31.50
- No. 4266—(1) 16 in. Medium 22.00
- No. 4267—(1) 18 in. Medium 31.50
- No. 4269—(1) 22 in. Medium 63.50

See Listing on Cymbal Pages for Other Sizes



"TROJAN" OUTFITS

IN RADIANT PEARL AND DELUXE CHROME
PLASTIC HEADS, UNLESS OTHERWISE SPECIFIED

No. 1825 - OUTFIT

Total List Value \$302.15

AS ILLUSTRATED
SPECIFY CHOICE OF PEARL

WITHOUT CYMBALS

\$293⁵⁰
TAX PAID

INCLUDES THESE DRUMS AND ACCESSORIES:

- 1—No. 87—HOLIDAY 14 x 20 BASS DRUM, choice of pearl \$136.00
- 1—No. 25—HOLIDAY 5 x 14 SNARE DRUM, choice of pearl ... 99.00

No. 1826 - OUTFIT

Total List Value \$311.15

AS ILLUSTRATED, BUT IN
THIS COMBINATION OF SIZES:

WITHOUT CYMBALS

\$302⁵⁰
TAX PAID

- 1—No. 91—HOLIDAY 14 x 22 BASS DRUM, choice of pearl \$145.00
- 1—No. 25—HOLIDAY 5 x 14 SNARE DRUM, choice of pearl ... 99.00

ACCESSORIES FOR "TROJAN" OUTFITS

NOS. 1825 . . . 1826

1 pr. Internal Spurs, chrome, No. 338R for 20" — No. 340R for 22"	\$10.95
1—No. 331R—Internal Cymbal Holder, chrome	8.00
1—No. 320R—SWIV-O-MATIC Cymbal Tilter, chrome	4.50
1—No. 398—Rocket Foot Pedal	25.00
1—No. 1716C—Drum Stand, chrome	10.50
1—No. 4788—Cow Bell	2.25
1—No. 4656—Cowbell Holder, chrome	3.00
1 pr. No. R-7A—Drum Sticks	1.20
1 pr. No. 943RC—Wire Brushes	1.75

CYMBALS FOR "TROJAN" OUTFITS

- No. 4328M—"AVEDIS ZILDJIAN" CYMBAL, 16 in. Medium \$36.30B
- No. 4256—"PASHA" CYMBAL, 16 in. Medium 22.00

See Listing on Cymbal Pages for Other Sizes

"VIKING" OUTFITS

IN RADIANT PEARL AND DELUXE CHROME
PLASTIC HEADS, UNLESS OTHERWISE SPECIFIED

No. 1820 - OUTFIT

Total List Value \$402.90

AS ILLUSTRATED
SPECIFY CHOICE OF PEARL

WITHOUT CYMBALS

\$390⁰⁰
TAX PAID

INCLUDES THESE DRUMS AND ACCESSORIES:

- 1—No. 87—HOLIDAY 14 x 20 BASS DRUM, choice of pearl \$136.00
- 1—No. 25—HOLIDAY 5 x 14 SNARE DRUM, choice of pearl ... 99.00
- 1—No. 51—HOLIDAY 8 x 12 TOM TOM, choice of pearl 74.00

No. 1821 - OUTFIT

Total List Value \$414.40

AS ILLUSTRATED, BUT IN
THIS COMBINATION OF SIZES:

WITHOUT CYMBALS

\$400⁰⁰
TAX PAID

- 1—No. 91—HOLIDAY 14 x 22 BASS DRUM, choice of pearl \$145.00
- 1—No. 25—HOLIDAY 5 x 14 SNARE DRUM, choice of pearl 99.00
- 1—No. 53—HOLIDAY 9 x 13 TOM TOM, choice of pearl 76.50



ACCESSORIES FOR "VIKING" OUTFITS

NOS. 1820 . . . 1821

1—No. 361R—SWIV-O-MATIC Tom Tom Holder, chrome	\$19.75
1 pr. Internal Spurs, chrome, No. 338R for 20" — No. 340R for 22"	10.95
1—No. 331R—Internal Cymbal Holder, chrome	8.00
1—No. 325R—SWIV-O-MATIC Cymbal Extension Arm, chrome	5.50
1—No. 320R—SWIV-O-MATIC Cymbal Tilter, chrome	4.50
1—No. 398—Rocket Foot Pedal	25.00
1—No. 1716C—Drum Stand, chrome	10.50
1—No. 4788—Cow Bell	2.25
1—No. 280R—Adjustable Cowbell Holder Assembly, chrome	4.50
1 pr. No. R-5A—Drum Sticks	1.20
1 pr. No. 943RC—Wire Brushes	1.75

CYMBALS FOR "VIKING" OUTFITS

- No. 4330M—"AVEDIS ZILDJIAN" CYMBAL, 18 in. Medium \$44.00B
- No. 4267—"PASHA" CYMBAL, 18 in. Medium 31.50

See Listing on Cymbal Pages for Other Sizes



"SWINGTIME" OUTFITS

IN RADIANT PEARL AND DELUXE CHROME — PLASTIC HEADS, UNLESS OTHERWISE SPECIFIED

Specifically designed and set up to meet the demands of today's professionals. Supplied in a choice selection of size combinations standardized to provide the ideal set-up for any and all types of performances.

For the modern jazz sound the discriminating drummer chooses Rogers. Top quality plus the flexibility possible with SWIV-O-MATIC and KNOBBY equipment makes drumming a pleasure.

No. 1816 - OUTFIT

Total List Value \$554.40

AS ILLUSTRATED
SPECIFY CHOICE OF PEARL

INCLUDES THESE DRUMS AND ACCESSORIES:

1—No. 87—HOLIDAY 14 x 20 BASS DRUM, choice of pearl	\$136.00
1—No. 25—HOLIDAY 5 x 14 SNARE DRUM, choice of pearl	99.00
1—No. 51—HOLIDAY 8 x 12 TOM TOM, choice of pearl	74.00
1—No. 59—HOLIDAY 16 x 16 TOM TOM, choice of pearl	96.00

WITHOUT CYMBALS

\$537⁵⁰

TAX
PAID

No. 1817 - OUTFIT

Total List Value \$565.90

AS ILLUSTRATED, BUT IN
THIS COMBINATION OF SIZES:

1—No. 91—HOLIDAY 14 x 22 BASS DRUM, choice of pearl	\$145.00
1—No. 25—HOLIDAY 5 x 14 SNARE DRUM, choice of pearl	99.00
1—No. 53—HOLIDAY 9 x 13 TOM TOM, choice of pearl	76.50
1—No. 59—HOLIDAY 16 x 16 TOM TOM, choice of pearl	96.00

WITHOUT CYMBALS

\$547⁵⁰

TAX
PAID

No. 1815 - OUTFIT

Total List Value \$546.90

AS ILLUSTRATED, BUT IN
THIS COMBINATION OF SIZES:

1—No. 87—HOLIDAY 14 x 20 BASS DRUM, choice of pearl	\$136.00
1—No. 25—HOLIDAY 5 x 14 SNARE DRUM, choice of pearl	99.00
1—No. 51—HOLIDAY 8 x 12 TOM TOM, choice of pearl	74.00
1—No. 55—HOLIDAY 14 x 14 TOM TOM, choice of pearl	88.50

WITHOUT CYMBALS

\$530⁰⁰

TAX
PAID

ACCESSORIES FOR "SWINGTIME" OUTFITS NOS. 1815 1816 1817

1—No. 361R—SWIV-O-MATIC Tom Tom Holder, chrome	\$19.75
1—No. 331R—Internal Cymbal Holder, chrome	8.00
1—No. 325R—SWIV-O-MATIC Cymbal Extension Arm, chrome	5.50
1—No. 320R—SWIV-O-MATIC Cymbal Tilting, chrome	4.50
1 pr. Internal Spurs, chrome	—
No. 338R for 20" — No. 340R for 22"	10.95
1 set KNOBBY Tam Tom Legs, chrome —	—
No. 275R for 16" — No. 276R for 14"	22.50
1—No. 288R—Stick Holder Assembly	11.50
1—No. 398—Rocket Foot Pedal	25.00
1—No. 1716C—Drum Stand, chrome	10.50
1—No. 1729C—Hi-Hat Sock Pedal, chrome	21.50
1—No. 4788—Cow Bell	2.25
1—No. 280R—Adjustable Cowbell Holder Assembly, chrome	4.50
1 pr. No. R-5A—Drum Sticks	1.20
1 pr. No. 943RC—Wire Brushes	1.75

CYMBALS FOR "SWINGTIME" OUTFITS

No. 4309 "AVEDIS ZILDJIAN" CYMBAL ASSORTMENT \$114^{40B}

TAX
PAID

No. 4340M—(2) 14 in. Hi-Hat, Medium @ \$29.700 \$59.400
No. 4332M—(1) 20 in. Medium \$5.000

No. 4353 "PASHA" CYMBAL ASSORTMENT \$72⁵⁰

TAX
PAID

No. 4265—(2) 14 in. Hi-Hat, Medium @ \$15.75 \$31.50
No. 4268—(1) 20 in. Medium \$41.00

See Listing on Cymbal Pages for Other Sizes

ROGERS WITH Swiv-O-Matic



"COZY COLE" OUTFITS

IN RADIANT PEARL AND DELUXE CHROME—PLASTIC HEADS UNLESS OTHERWISE SPECIFIED

No. 1830 - OUTFIT

Total List Value \$861.65

WITHOUT CYMBALS

\$835.00

TAX PAID

AS ILLUSTRATED
SPECIFY CHOICE OF PEARL

INCLUDES THESE DRUMS AND ACCESSORIES:

- 1—No. 87—HOLIDAY 14 x 20 BASS DRUM, choice of pearl \$136.00
- 1—No. 25—HOLIDAY 5 x 14 SNARE DRUM, choice of pearl 99.00
- 1—No. 51—HOLIDAY 8 x 12 TOM TOM, choice of pearl 74.00
- 1—No. 53—HOLIDAY 9 x 13 TOM TOM, choice of pearl 76.50
- 2—No. 59—HOLIDAY 16 x 16 TOM TOMS,
choice of pearl @ \$96.00 192.00

ACCESSORIES FOR "COZY COLE" OUTFITS

- 2—No. 380R—SWIV-O-MATIC All-Purpose Holders,
chrome at \$19.75 \$39.50
for mounting Snare Drum and 8 x 12 Tom Tom
on Bass Drum
- 2—No. 331R—Internal Cymbal Holders, chrome @ \$8.00 16.00
- 1 pr. No. 338R—Internal Spurs, chrome 10.95
- 1—No. 252R—KNOBBY Telescopic Cymbal Holders, chrome 13.50
- 3—No. 325R—SWIV-O-MATIC Cymbal Extension Arms,
chrome @ \$5.50 16.50
- 3—No. 320R—SWIV-O-MATIC Cymbal Tilters, chrome @ \$4.50 13.50
- 1—No. 249R—KNOBBY Shell-Mount Cymbal Holder, chrome 8.25
for mounting cymbal on floor Tom Tom
- 1—No. 382R—SWIV-O-MATIC All-Purpose Holder, chrome 19.75
for mounting 9 x 13 Tom Tom on floor Tom Tom
- 2—No. 221R—KNOBBY Shell-Mount Units, chrome @ \$6.00 12.00
mounted on floor Tom Tom for conversion purposes
- 2 sets No. 275R—KNOBBY Tom Tom Legs, chrome @ \$22.50 45.00
- 1—No. 398—Rocket Foot Pedal 25.00
- 1—No. 1729C—Hi-Hat Sock Pedal, chrome 21.50
- 1—No. 205R—Cocktail Up Beat Foot Pedal 22.50
- 1—No. 4788—Cow Bell 2.25
- 1—No. 280R—Adjustable Cowbell Holder Assembly chrome 4.50
- 1—No. 287R—Stick Holder Assembly, chrome 10.50
- 1 pr. No. R-4A—Drum Sticks 1.20
- 1 pr. No. 943RC—Wire Brushes 1.75

CYMBALS FOR "COZY COLE" OUTFITS

No. 4310 "AVEDIS ZILDJIAN" CYMBAL ASSORTMENT **\$222.20**

TAX PAID

- No. 4322—(1) 10 in. Paper Thin \$16.50B
- No. 4340M—(2) 14 in. Hi-Hat, Medium @ \$29.70B 59.40B
- No. 4328M—(1) 16 in. Medium 36.30B
- No. 4330M—(1) 18 in. Medium 44.00B
- No. 4334M—(1) 22 in. Medium 66.00B

No. 4354 "PASHA" CYMBAL ASSORTMENT **\$154.50**

TAX PAID

- No. 4301—(1) 10 in. Medium \$ 6.00
- No. 4265—(2) 14 in. Hi-Hat, Medium @ \$15.75 31.50
- No. 4266—(1) 16 in. Medium 22.00
- No. 4267—(1) 18 in. Medium 31.50
- No. 4269—(1) 22 in. Medium 63.50

See Listing on Cymbal Pages for Other Sizes

ROGERS WITH Swiv-O-Matic

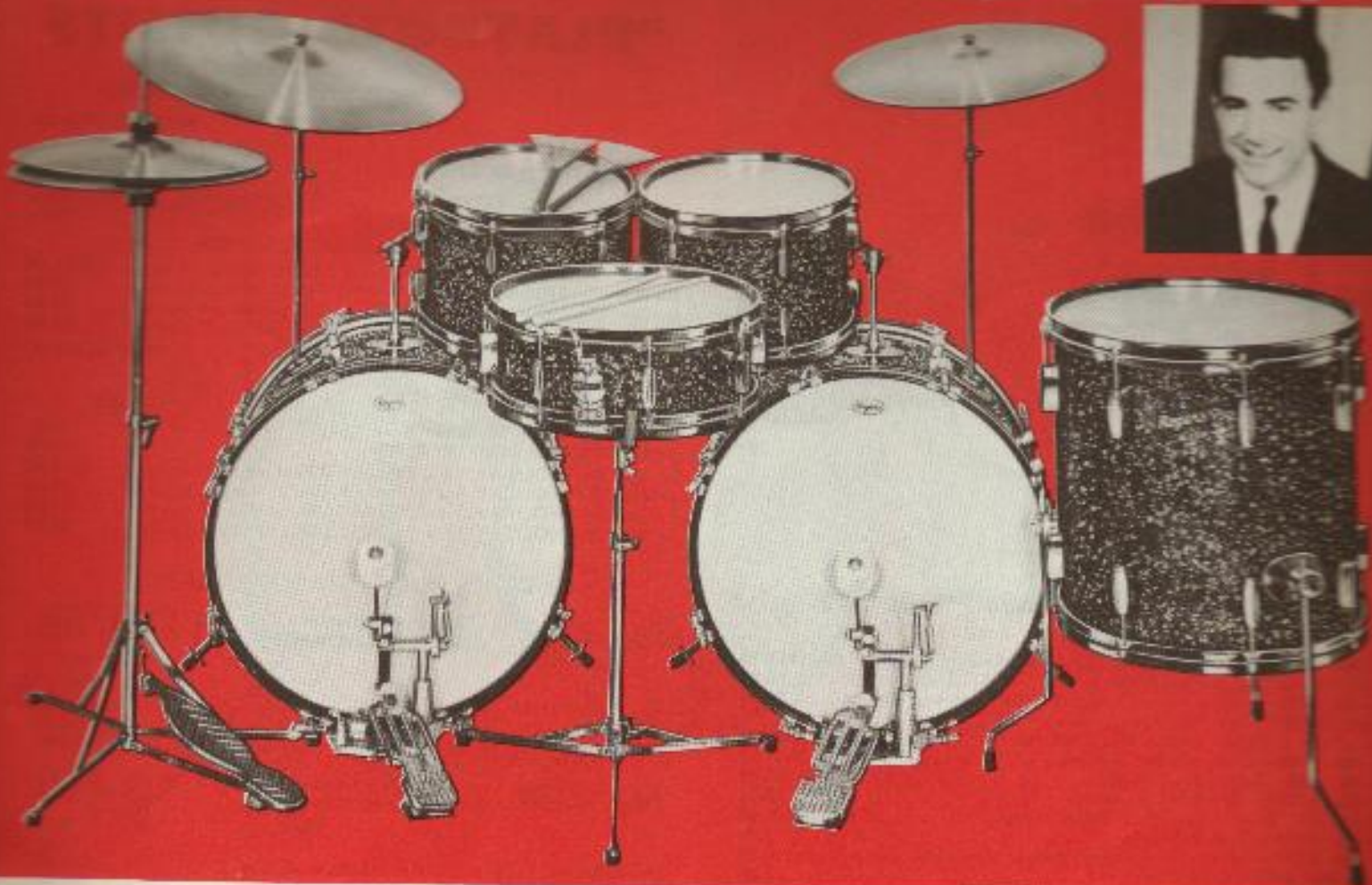

"LOUIS BELLSON" TWIN BASS OUTFITS

IN RADIANT PEARL AND DELUXE CHROME-PLASTIC HEADS, UNLESS OTHERWISE SPECIFIED

No. 1837 - OUTFIT

Total List Value \$863.15

AS ILLUSTRATED

SPECIFY CHOICE OF PEARL

INCLUDES THESE DRUMS AND ACCESSORIES:

2—No. 91—HOLIDAY 14 x 22 BASS DRUMS, choice of pearl @ \$145.00	\$290.00
1—No. 25—HOLIDAY 5 x 14 SNARE DRUM, choice of pearl	99.00
2—No. 53—HOLIDAY 9 x 13 TOM TOMS, choice of pearl @ \$76.50	153.00
1—No. 59—HOLIDAY 16 x 16 TOM TOM, choice of pearl	96.00

WITHOUT CYMBALS

\$837⁵⁰

TAX PAID

No. 1836 - OUTFIT

Total List Value \$840.15

AS ILLUSTRATED, BUT IN

THIS COMBINATION OF SIZES:

2—No. 87—HOLIDAY 14 x 20 BASS DRUMS, choice of pearl @ \$136.00	\$272.00
1—No. 25—HOLIDAY 5 x 14 SNARE DRUM, choice of pearl	99.00
2—No. 51—HOLIDAY 8 x 12 TOM TOMS, choice of pearl @ \$74.00	148.00
1—No. 59—HOLIDAY 16 x 16 TOM TOM, choice of pearl	96.00

WITHOUT CYMBALS

\$815⁰⁰

TAX PAID

No. 1835 - OUTFIT

Total List Value \$832.15

AS ILLUSTRATED, BUT IN

THIS COMBINATION OF SIZES:

2—No. 87—HOLIDAY 14 x 20 BASS DRUMS, choice of pearl @ \$136.00	\$272.00
1—No. 25—HOLIDAY 5 x 14 SNARE DRUM, choice of pearl	99.00
2—No. 51—HOLIDAY 8 x 12 TOM TOMS, choice of pearl @ \$74.00	148.00
1—No. 55—HOLIDAY 14" x 14" TOM TOM, choice of pearl	88.50

WITHOUT CYMBALS

\$807⁵⁰

TAX PAID

FOR DYNA-SONIC SNARE DRUM, ADD \$20.00

ACCESSORIES FOR "LOUIS BELLSON" OUTFITS

Nos. 1835 . . . 1836 . . . 1837

2—No. 361R—SWIV-O-MATIC Tom Tom Holders, chrome @ \$19.75	\$ 39.50
2—No. 252R—KNOBBY Telescopic Cymbal Holders, chrome @ \$13.50	27.00
2 pr. Internal Spurs @ \$10.95	21.90
No. 340R for 22" — No. 338R for 20"	21.90
1 set KNOBBY Tom Tom Legs, Chrome	\$ 22.50
No. 275R for 16" — No. 276R for 14"	79.00
2—SWIV-O-MATIC Foot Pedals, Specify choice @ \$39.50	79.00
No. 395R (solid footboard) or No. 396R (hinged footboard)	10.50
1—No. 1716C—Drum Stand, chrome	21.50
1—No. 1729C—Hi-Hat Sock Pedal, chrome	1.50
1 pr. No. LB—Drum Sticks	1.75
1 pr. No. 943RC—Wire Brushes	1.75

CYMBALS FOR "LOUIS BELLSON" OUTFITS

No. 4315 "AYEDIS ZILDJIAN" CYMBAL ASSORTMENT **\$150^{70B}**

TAX PAID

No. 4340M—(2) 14 in. Hi-Hat, Medium @ \$29.70B	\$59.40B
No. 4328M—(1) 16 in. Medium	\$4.30B
No. 4332M—(1) 20 in. Medium	\$5.00B

No. 4359 "PASHA" CYMBAL ASSORTMENT **\$94⁵⁰**

TAX PAID

No. 4265—(2) 14 in. Hi-Hat, Medium @ \$15.75	\$31.50
No. 4266—(1) 16 in. Medium	\$2.00
No. 4268—(1) 20 in. Medium	\$1.00

See Listing on Cymbal Page for Other Sizes

"PLAYBOY" OUTFITS

IN RADIANT PEARL AND DELUXE CHROME
PLASTIC HEADS, UNLESS OTHERWISE SPECIFIED

No. 1840 - OUTFIT

Total List Value \$557.90

WITHOUT CYMBALS

\$540⁰⁰

TAX PAID

AS ILLUSTRATED
SPECIFY CHOICE OF PEARL

INCLUDES THESE DRUMS AND ACCESSORIES:

- 1—No. 87—HOLIDAY 14 x 20 BASS DRUM, choice of pearl ... \$136.00
- 1—No. 25—HOLIDAY 5 x 14 SNARE DRUM, choice of pearl ... 99.00
- 1—No. 51—HOLIDAY 8 x 12 TOM TOM, choice of pearl ... 74.00
- 1—No. 55—HOLIDAY 14 x 14 TOM TOM, choice of pearl ... 88.50

No. 1841 - OUTFIT

Total List Value \$576.90

WITHOUT CYMBALS

\$557⁵⁰

TAX PAID

AS ILLUSTRATED, BUT IN
THIS COMBINATION OF SIZES:

- 1—No. 91—HOLIDAY 14 x 22 BASS DRUM, choice of pearl ... \$145.00
- 1—No. 25—HOLIDAY 5 x 14 SNARE DRUM, choice of pearl ... 99.00
- 1—No. 53—HOLIDAY 9 x 13 TOM TOM, choice of pearl ... 76.50
- 1—No. 59—HOLIDAY 16 x 16 TOM TOM, choice of pearl ... 96.00



ACCESSORIES FOR "PLAYBOY" OUTFITS NOS. 1840 1841

- 1—No. 361R—SWIV-O-MATIC Tom Tom Holder, chrome ... \$19.75
- 1 pr. Internal Spurs—No. 338R for 20" — No. 340R for 22" ... 10.95
- 2—No. 4403—Rogers Floor Cymbal Stands, chrome @ \$14.50 ... 29.00
- 1 set KNOBBY Tom Tom Legs, chrome —
No. 275R for 16" — No. 276R for 14" ... 22.50
- 1—No. 288R—Stick Holder Assembly ... 11.50
- 1—No. 398—Rocket Foot Pedal ... 25.00
- 1—No. 1716C—Drum Stand, chrome ... 10.50
- 1—No. 1729C—Hi-Hat Sock Pedal, chrome ... 21.50
- 1—No. 4788—Cow Bell ... 2.25
- 1—No. 280R—Adjustable Cowbell Holder Assembly, chrome ... 4.50
- 1 pr. No. R-5A—Drum Sticks ... 1.20
- 1 pr. No. 943RC—Wire Brushes ... 1.75

"ORBIT" OUTFITS

IN RADIANT PEARL AND DELUXE CHROME
PLASTIC HEADS, UNLESS OTHERWISE SPECIFIED

No. 1845 - OUTFIT

Total List Value, \$542.90

WITHOUT CYMBALS

\$527⁵⁰

TAX PAID

AS ILLUSTRATED
SPECIFY CHOICE OF PEARL

INCLUDES THESE DRUMS AND ACCESSORIES:

- 1—No. 85—HOLIDAY 12 x 20 BASS DRUM, choice of pearl ... \$133.00
- 1—No. 25—HOLIDAY 5 x 14 SNARE DRUM, choice of pearl ... 99.00
- 1—No. 51—HOLIDAY 8 x 12 TOM TOM, choice of pearl ... 74.00
- 1—No. 55—HOLIDAY 14 x 14 TOM TOM, choice of pearl ... 88.50

No. 1846 - OUTFIT

Total List Value \$559.90

WITHOUT CYMBALS

\$542⁵⁰

TAX PAID

AS ILLUSTRATED, BUT IN
THIS COMBINATION OF SIZES

- 1—No. 89—HOLIDAY 12 x 22 BASS DRUM, choice of pearl ... \$140.00
- 1—No. 25—HOLIDAY 5 x 14 SNARE DRUM, choice of pearl ... 99.00
- 1—No. 53—HOLIDAY 9 x 13 TOM TOM, choice of pearl ... 76.50
- 1—No. 59—HOLIDAY 16 x 16 TOM TOM, choice of pearl ... 96.00

CYMBALS FOR "ORBIT" OUTFITS

No. 4309 "AVEDIS ZILDJIAN" CYMBAL ASSORTMENT **\$114⁴⁰B**

TAX PAID

- No. 4340M—(2) 14 in. Hi-Hat, Medium @ \$29.70B ... \$59.40B
- No. 4332M—(1) 20 in. Medium ... 55.00B

No. 4353 "PASHA" CYMBAL ASSORTMENT **\$72⁵⁰**

TAX PAID

- No. 4265—(2) 14 in. Hi-Hat, Medium @ \$15.75 ... \$31.50
- No. 4268—(1) 20 in. Medium ... 41.00

See Listing on Cymbal Pages for Other Sizes

CYMBALS FOR "PLAYBOY" OUTFITS

No. 4315 "AVEDIS ZILDJIAN" CYMBAL ASSORTMENT **\$150⁷⁰B**

TAX PAID

- No. 4340M—(2) 14 in. Hi-Hat, Medium @ \$29.70B ... \$59.40B
- No. 4328M—(1) 16 in. Medium ... 36.30B
- No. 4332M—(1) 20 in. Medium ... 55.00B

No. 4359 "PASHA" CYMBAL ASSORTMENT **\$94⁵⁰**

TAX PAID

- No. 4265—(2) 14 in. Hi-Hat, Medium @ \$15.75 ... \$31.50
- No. 4266—(1) 16 in. Medium ... 22.00
- No. 4268—(1) 20 in. Medium ... 41.00

See Listing on Cymbal Pages for Other Sizes



ACCESSORIES FOR "ORBIT" OUTFITS

NOS. 1845 1846

- 1—No. 361R—SWIV-O-MATIC Tom Tom Holder, chrome ... \$19.75
- 1—No. 331R—Internal Cymbal Holder, chrome ... 8.00
- 1—No. 325R—SWIV-O-MATIC Cymbal Extension Arm, chrome ... 5.50
- 1—No. 320R—SWIV-O-MATIC Cymbal Tilter, chrome ... 4.50
- 1 pr. Internal Spurs, chrome—No. 338R for 20" — No. 340R for 22" ... 10.95
- 1 set KNOBBY Tom Tom legs, chrome—276R for 14"; 275R for 16" ... 22.50
- 1—No. 287R—Stick Holder Assembly ... 10.50
- 1—No. 398—Rocket Foot Pedal ... 25.00
- 1—No. 1716C—Drum Stand, chrome ... 10.50
- 1—No. 1729C—Hi-Hat Sock Pedal, chrome ... 21.50
- 1—No. 4788—Cow Bell ... 2.25
- 1—No. 280R—Adjustable Cowbell Holder Assembly ... 4.50
- 1 pr. No. R-7A—Drum Sticks ... 1.20
- 1 pr. No. 943RC—Wire Brushes ... 1.75

ROGERS WITH Swiv-O-Matic



"CONSTELLATION" OUTFITS

IN RADIANT PEARL AND DELUXE CHROME—PLASTIC HEADS UNLESS OTHERWISE SPECIFIED

No. 1852 - OUTFIT

Total List Value \$582.65

AS ILLUSTRATED
SPECIFY CHOICE OF PEARL

INCLUDES THESE DRUMS AND ACCESSORIES:

1—No. 91—HOLIDAY 14 x 22 BASS DRUM, choice of pearl	\$145.00
1—No. 25—HOLIDAY 5 x 14 SNARE DRUM, choice of pearl	99.00
1—No. 53—HOLIDAY 9 x 13 TOM TOM, choice of pearl	76.50
1—No. 59—HOLIDAY 16 x 16 TOM TOM, choice of pearl	96.00

No. 1851 - OUTFIT

Total List Value \$571.15

AS ILLUSTRATED, BUT IN
THIS COMBINATION OF SIZES:

1—No. 87—HOLIDAY 14 x 20 BASS DRUM, choice of pearl	\$136.00
1—No. 25—HOLIDAY 5 x 14 SNARE DRUM, choice of pearl	99.00
1—No. 51—HOLIDAY 8 x 12 TOM TOM, choice of pearl	74.00
1—No. 59—HOLIDAY 16 x 16 TOM TOM, choice of pearl	96.00

No. 1850 - OUTFIT

Total List Value \$563.65

AS ILLUSTRATED, BUT IN
THIS COMBINATION OF SIZES:

1—No. 87—HOLIDAY 14 x 20 BASS DRUM, choice of pearl	\$136.00
1—No. 25—HOLIDAY 5 x 14 SNARE DRUM, choice of pearl	99.00
1—No. 51—HOLIDAY 8 x 12 TOM TOM, choice of pearl	74.00
1—No. 55—HOLIDAY 14 x 14 TOM TOM, choice of pearl	88.50

FOR SYN-A-SONIC SNARE DRUM, ADD \$20.00

WITHOUT CYMBALS

\$565.00
TAX PAID

ACCESSORIES FOR "CONSTELLATION" OUTFITS NOS. 1850 . . . 1851 . . . 1852

1—No. 360R—SWIV-O-MATIC Tom Tom Holder, chrome	\$14.75
2—No. 331R—Internal Cymbal Holders, chrome @ \$8.00	16.00
1—No. 325R—SWIV-O-MATIC Cymbal Extension Arm, chrome	5.50
2—No. 320R—SWIV-O-MATIC Cymbal Tilters, chrome @ \$4.50	9.00
1 pr. Internal Spurs, chrome — No. 340R for 22" — No. 338R for 20"	18.95
1 set—KNOBBY Tom Tom Legs, chrome, No. 275R for 16" — No. 276R for 14"	22.50
1—No. 288R—Stick Holder Assembly	11.50
1—No. 398—Rocket Foot Pedal	25.00
1—No. 1716C—Drum Stand, chrome	18.50
1—No. 1729C—Hi-Hat Sock Pedal, chrome	21.50
1—No. 4788—Cow Bell	2.25
1—No. 4817R—Wood Block	2.75
1—No. 4813—Combination Cow Bell and Wood Block Holder, chrome	6.00
1 pr. No. R-2A—Drum Sticks	1.25
1 pr. No. 943RC—Wire Brushes	1.75

CYMBALS FOR "CONSTELLATION" OUTFITS

No. 4313 "AVEDIS ZILDJIAN" CYMBAL ASSORTMENT **\$139.70B**

No. 4340M—(2) 14 in. Hi-Hat, Medium @ \$29.70B	\$59.40B
No. 4328M—(1) 16 in. Medium	24.30B
No. 4330M—(1) 18 in. Medium	44.00B

No. 4357 "PASHA" CYMBAL ASSORTMENT **\$85.00**

No. 4265—(2) 14 in. Hi-Hat, Medium @ \$15.75	\$31.50
No. 4266—(1) 16 in. Medium	22.00
No. 4267—(1) 18 in. Medium	31.50

See Listing on Cymbal Pages for Other Sizes

ROGERS WITH Swiv-O-Matic

"SKYLINE" OUTFITS

IN RADIANT PEARL AND DELUXE CHROME
PLASTIC HEADS UNLESS OTHERWISE SPECIFIED

No. 1855 - OUTFIT

Total List Value \$412.15

WITHOUT CYMBALS

\$400⁰⁰
TAX PAID

AS ILLUSTRATED
SPECIFY CHOICE OF PEARL

INCLUDES THESE DRUMS AND ACCESSORIES:

- | | |
|---|----------|
| 1—No. 87—HOLIDAY 14 x 20 BASS DRUM, choice of pearl | \$136.00 |
| 1—No. 25—HOLIDAY 5 x 14 SNARE DRUM, choice of pearl | 99.00 |
| 1—No. 51—HOLIDAY 8 x 12 TOM TOM, choice of pearl | 74.00 |

ACCESSORIES FOR "SKYLINE" OUTFITS

- | | |
|--|---------|
| 1—No. 360R—SWIV-O-MATIC Tom Tom Holder, chrome | \$19.75 |
| 1—No. 380R—SWIV-O-MATIC All-Purpose Holder, chrome
for mounting snare drum on bass drum | 19.75 |
| 1—No. 331R—Internal Cymbal Holder, chrome | 8.00 |
| 1—No. 325R—SWIV-O-MATIC Cymbal Extension Arm, chrome | 5.50 |
| 1—No. 320R—SWIV-O-MATIC Cymbal Tilter, chrome | 4.50 |
| 1 pr. No. 338R—Internal Spurs, chrome | 10.95 |
| 1—No. 398—Rocket Foot Pedal | 25.00 |
| 1—No. 4788—Cow Bell | 2.25 |
| 1—No. 280R—Adjustable Cowbell Holder Assembly, chrome | 4.50 |
| 1 pr. No. R-2A—Drum Sticks | 1.20 |
| 1 pr. No. 943RC—Wire Brushes | 1.75 |



CYMBALS FOR "SKYLINE" OUTFITS

- | | |
|---|----------|
| No. 4330M—"AVEDIS ZILDJIAN" CYMBAL, 18 in. Medium | \$44.00B |
| No. 4267—"PASHA" CYMBAL, 18 in. Medium | 31.50 |

See Listing on Cymbal Pages for Other Sizes

"FESTIVAL" OUTFITS

IN RADIANT PEARL AND DELUXE CHROME
PLASTIC HEADS, UNLESS OTHERWISE SPECIFIED

No. 1860 - OUTFIT

Total List Value \$574.15

WITHOUT CYMBALS

\$557⁵⁰
TAX PAID

AS ILLUSTRATED
SPECIFY CHOICE OF PEARL

INCLUDES THESE DRUMS AND ACCESSORIES:

- | | |
|--|----------|
| 1—No. 87—HOLIDAY 14 x 20 BASS DRUM,
choice of pearl | \$136.00 |
| 1—No. 25—HOLIDAY 5 x 14 SNARE DRUM, choice of pearl | 99.00 |
| 1—No. 51—HOLIDAY 8 x 12 TOM TOM, choice of pearl | 74.00 |
| 1—No. 55—HOLIDAY 14 x 14 TOM TOM, choice of pearl | 88.50 |

No. 1861 - OUTFIT

Total List Value \$581.65

WITHOUT CYMBALS

\$565⁰⁰
TAX PAID

AS ILLUSTRATED, BUT IN
THIS COMBINATION OF SIZES:

- | | |
|--|----------|
| 1—No. 87—HOLIDAY 14 x 20 BASS DRUM,
choice of pearl | \$136.00 |
| 1—No. 25—HOLIDAY 5 x 14 SNARE DRUM, choice of pearl | 99.00 |
| 1—No. 51—HOLIDAY 8 x 12 TOM TOM, choice of pearl | 74.00 |
| 1—No. 59—HOLIDAY 16 x 16 TOM TOM, choice of pearl | 96.00 |



ACCESSORIES FOR "FESTIVAL" OUTFITS

NOS. 1860 1861

- | | |
|--|---------|
| 2—No. 380R—SWIV-O-MATIC All-Purpose Holders,
chrome @ \$19.75
for mounting snare drum and 8" x 12"
Tom Tom on bass drum | \$39.50 |
| 2—No. 331R—Internal Cymbal Holders, chrome @ \$8.00 | 16.00 |
| 2—No. 325R—SWIV-O-MATIC Cymbal Extension Arms,
chrome @ \$5.50 | 11.00 |
| 2—No. 320R—SWIV-O-MATIC Cymbal Tilters, chrome @ \$4.50 | 9.00 |
| 1 pr. No. 338R—Internal Spurs, chrome | 10.95 |
| 1 Set KNOBBY Tom Tom Legs, chrome,
No. 276R for 14" — No. 275R for 16" | 22.50 |
| 1—No. 398—Rocket Foot Pedal | 25.00 |
| 1—No. 1729C—Hi-Hat Sock Pedal, chrome | 21.50 |
| 1—No. 288R—Stick Holder Assembly | 11.50 |
| 1—No. 4788—Cow Bell | 2.25 |
| 1—No. 280R—Adjustable Cowbell Holder Assembly, chrome | 4.50 |
| 1 pr. No. R-4A—Drum Sticks | 1.20 |
| 1 pr. No. 943RC—Wire Brushes | 1.75 |

CYMBALS FOR "FESTIVAL" OUTFITS

No. 4314 "AVEDIS ZILDJIAN" CYMBAL ASSORTMENT **\$161^{70B}**
TAX PAID

- | | |
|--|----------|
| No. 4340M—(2) 14 in. Hi-Hat, Medium @ \$29.70B | \$59.40B |
| No. 4328M—(1) 16 in. Medium | 36.30B |
| No. 4334M—(1) 22 in. Medium | 66.00B |

No. 4358 "PASHA" CYMBAL ASSORTMENT **\$94⁵⁰**
TAX PAID

- | | |
|--|---------|
| No. 4265—(2) 14 in. Hi-Hat, Medium @ \$15.75 | \$31.50 |
| No. 4266—(1) 16 in. Medium | 22.00 |
| No. 4269—(1) 22 in. Medium | 41.00 |

See Listing on Cymbal Pages for Other Sizes

ROGERS WITH Swiv-O-Matic



"STARLITE" OUTFITS

IN RADIANT PEARL AND DELUXE CHROME—PLASTIC HEADS UNLESS OTHERWISE SPECIFIED

No. 1866 - OUTFIT

Total List Value \$563.65

AS ILLUSTRATED
SPECIFY CHOICE OF PEARL

WITHOUT CYMBALS

\$547⁵⁰

TAX
PAID

INCLUDES THESE DRUMS AND ACCESSORIES:

- 1—No. 87—HOLIDAY 14 x 20 BASS DRUM, choice of pearl . . . \$136.00
- 1—No. 25—HOLIDAY 5 x 14 SNARE DRUM, choice of pearl . . . 99.00
- 1—No. 51—HOLIDAY 8 x 12 TOM TOM, choice of pearl 74.00
- 1—No. 59—HOLIDAY 16 x 16 TOM TOM, choice of pearl 96.00

No. 1865 - OUTFIT

Total List Value \$556.15

AS ILLUSTRATED, BUT IN
THIS COMBINATION OF SIZES:

WITHOUT CYMBALS

\$540⁰⁰

TAX
PAID

- 1—No. 87—HOLIDAY 14 x 20 BASS DRUM, choice of pearl . . . \$136.00
- 1—No. 25—HOLIDAY 5 x 14 SNARE DRUM, choice of pearl . . . 99.00
- 1—No. 51—HOLIDAY 8 x 12 TOM TOM, choice of pearl 74.00
- 1—No. 55—HOLIDAY 14 x 14 TOM TOM, choice of pearl 88.50

ACCESSORIES FOR "STARLITE" OUTFITS

NOS. 1865 1866

- 1—No. 360R—SWIV-O-MATIC Tom Tom Holder, chrome \$19.75
- 1—No. 380R—SWIV-O-MATIC All-Purpose Holder, chrome 19.75
for mounting snare drum on bass drum
- 1—No. 331R—Internal Cymbal Holder, chrome 8.00
- 1—No. 325R—SWIV-O-MATIC Cymbal Extension Arm, chrome 5.50
- 1—No. 320R—SWIV-O-MATIC Cymbal Tilter, chrome 4.50
- 1 pr. No. 338R—Internal Spurs, chrome 10.95
- 1 set KNOBBY Tom Tom Legs, chrome —
No. 275R for 16" — No. 276R for 14" 22.50
- 1—No. 398—Rocket Foot Pedal 25.00
- 1—No. 1729C—Hi-Hat Sock Pedal, chrome 21.50
- 1—No. 288R—Stick Holder Assembly 11.50
- 1—No. 4788—Cow Bell 2.25
- 1—No. 280R—Adjustable Cowbell Holder Assembly, chrome 4.50
- 1 pr. No. R-2A—Drum Sticks 1.20
- 1 pr. No. 943RC—Wire Brushes 1.75

CYMBALS FOR "STARLITE" OUTFITS

No. 4309 "AVEDIS ZILDJIAN" CYMBAL ASSORTMENT \$114^{40B}

TAX

PAID

- No. 4340M—(2) 14 in. Hi-Hat, Medium @ \$29.708 \$59.408
- No. 4332M—(1) 20 in. Medium 55.008

No. 4353 "PASHA" CYMBAL ASSORTMENT \$72⁵⁰

TAX

PAID

- No. 4265—(2) 14 in. Hi-Hat, Medium @ \$15.75 \$31.50
- No. 4268—(1) 20 in. Medium 41.00

See Listing on Cymbal Page for Other Sizes

POSITION MARKERS ON TOM TOM LEGS
Rogers Knobby hex legs, as well as Rogers round tom tom legs have position markers notched for even height adjustment.

INTERNAL SPURS
Rogers Internal or disappearing spurs have no peer in the drum world. Hex shafts conceal drum. Crisp ping prevent dropping in. Collars are less.

ROGERS WITH Swiv-O-Matic

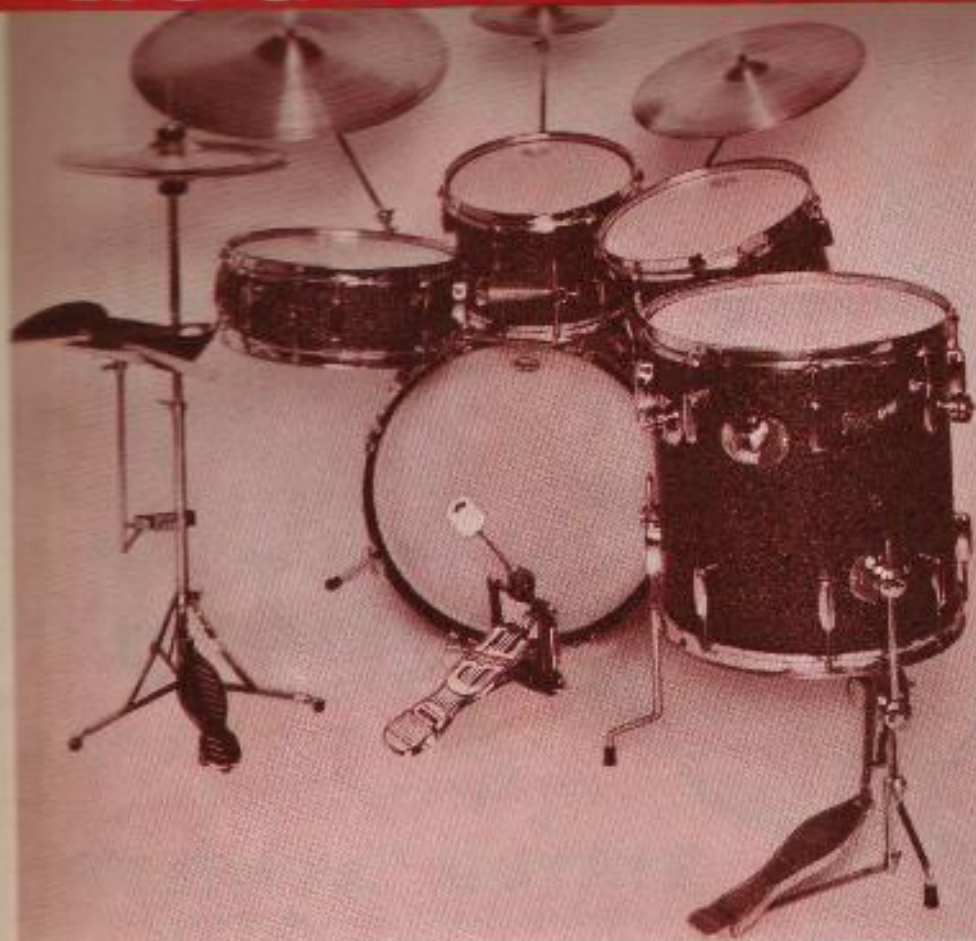

SHOWCASE OUTFIT

The most exciting line in the drum world . . . growing in popularity because of sets like this. Superb Rogers sound, smart and sparkling Rogers styling . . . a terrific set-up at a terrific price. You have to see and try Rogers to appreciate it. Here's why . . . Note how easily this 'Showcase' set converts to a combo outfit. Transfer the snare drum and cymbals to the floor tom-tom and you're ready. Versatility possible only with Rogers and Swiv-o-matic.

← From this to this →



"SHOWCASE" OUTFITS

IN RADIANT PEARL AND DELUXE CHROME
PLASTIC HEADS, UNLESS OTHERWISE SPECIFIED

No. 1870 - OUTFIT

Total List Value \$731.90

AS ILLUSTRATED
SPECIFY CHOICE OF PEARL

INCLUDES THESE DRUMS AND ACCESSORIES:

1—No. 87—HOLIDAY 14 x 20 BASS DRUM, choice of pearl	\$136.00
1—No. 25—HOLIDAY 5 x 14 SNARE DRUM, choice of pearl	99.00
1—No. 51—HOLIDAY 8 x 12 TOM TOM, choice of pearl	74.00
1—No. 53—HOLIDAY 9 x 13 TOM TOM, choice of pearl	76.50
1—No. 59—HOLIDAY 16 x 16 TOM TOM, choice of pearl	96.00

WITHOUT CYMBALS

\$710⁰⁰
TAX PAID

ACCESSORIES FOR "SHOWCASE" OUTFITS

2—No. 380R—SWIV-O-MATIC All-Purpose Holders, chrome @ \$19.75	\$39.50
1 pr. No. 338R—Internal Spurs, chrome	10.95
2—No. 331R—Internal Cymbal Holders, chrome @ \$8.00	16.00
2—No. 325R—SWIV-O-MATIC Cymbal Extension Arms, chrome @ \$5.50	11.00
2—No. 320R—SWIV-O-MATIC Cymbal Tilters, chrome @ \$4.50	9.00
1—No. 252R—KNOBBY Telescopic Cymbal Holder, chrome	13.50
1—No. 382R—SWIV-O-MATIC All-Purpose Holder, chrome for mounting 9" x 13" Tom Tom on floor Tom Tom	19.75
1 set No. 275R—KNOBBY Tom Tom Legs, chrome	22.50
3—No. 221R—KNOBBY Shell-Mount Units, chrome @ \$6.00 mounted on floor Tom Tom for conversion purposes	18.00
1—No. 398—Rocket Foot Pedal	25.00
1—No. 1729C—Hi-Hat Sock Pedal, chrome	21.50
1—No. 205R—Cocktail Foot Pedal	22.50
1 pr. No. R-4A—Drum Sticks	1.20
1 pr. No. 943RC—Wire Brushes	1.75
1—No. 478B—Cow Bell	2.25
1—No. 288R—Stick Holder Assembly, chrome	11.50
1—No. 280R—Adjustable Cowbell Holder Assembly, chrome	4.50

CYMBALS FOR "SHOWCASE" OUTFITS

No. 4311 "AYEDIS ZILDJIAN" CYMBAL ASSORTMENT **\$178^{20B}**

No. 4322—(1) 10 in. Paper Thin	\$16.50
No. 4340M—(2) 14 in. Hi-Hat, Medium @ \$29.70B	59.40B
No. 4328M—(1) 16 in. Medium	36.30B
No. 4334M—(1) 22 in. Medium	66.00B

No. 4355 "PASHA" CYMBAL ASSORTMENT **\$123⁰⁰**

No. 4301—(1) 10 in. Paper Thin	\$ 6.00
No. 4265—(2) 14 in. Hi-Hat, Medium @ \$15.75	31.50
No. 4266—(1) 16 in. Medium	22.00
No. 4269—(1) 22 in. Medium	63.50

See listing on Cymbal Page for Other Sizes

ROGERS WITH Swiv-O-Matic



"TOP-HAT OUTFITS"

IN RADIANT PEARL AND DELUXE CHROME-PLASTIC HEADS, UNLESS OTHERWISE SPECIFIED

No. 1876 - OUTFIT

Total List Value \$658.35

AS ILLUSTRATED
SPECIFY CHOICE OF PEARL

WITHOUT CYMBALS

\$637⁵⁰

TAX
PAID

INCLUDES THESE DRUMS AND ACCESSORIES:

- 1—No. 87—HOLIDAY 14 x 20 BASS DRUM, choice of pearl ... \$136.00
- 1—No. 25—HOLIDAY 5 x 14 SNARE DRUM, choice of pearl ... 99.00
- 2—No. 51—HOLIDAY 8 x 12 TOM TOMS,
choice of pearl, @ \$74.00 ... 148.00
- 1—No. 59—HOLIDAY 16 x 16 TOM TOM, choice of pearl ... 96.00

No. 1877 - OUTFIT

Total List Value \$672.35

AS ILLUSTRATED, BUT IN
THIS COMBINATION OF SIZES:

WITHOUT CYMBALS

\$650⁰⁰

TAX
PAID

- 1—No. 91—HOLIDAY 14 x 22 BASS DRUM, choice of pearl ... \$145.00
- 1—No. 25—HOLIDAY 5 x 14 SNARE DRUM, choice of pearl ... 99.00
- 2—No. 53—HOLIDAY 9 x 13 TOM TOMS,
choice of pearl @ \$76.50 ... 153.00
- 1—No. 59—HOLIDAY 16 x 16 TOM TOM, choice of pearl ... 96.00

No. 1875 - OUTFIT

Total List Value \$650.85

AS ILLUSTRATED, BUT IN
THIS COMBINATION OF SIZES:

WITHOUT CYMBALS

\$630⁰⁰

TAX
PAID

- 1—No. 87—HOLIDAY 14 x 20 BASS DRUM, choice of pearl ... \$136.00
- 1—No. 25—HOLIDAY 5 x 14 SNARE DRUM, choice of pearl ... 99.00
- 2—No. 51—HOLIDAY 8 x 12 TOM TOMS,
choice of pearl @ \$74.00 ... 148.00
- 1—No. 55—HOLIDAY 14 x 14 TOM TOM, choice of pearl ... 88.50

ACCESSORIES FOR "TOP-HAT" OUTFITS NOS. 1875 1876 1877

- 1—No. 365R—SWIV-O-MATIC Twin Tom Tom Holder, chrome ... \$39.50
- 1 pr. Internal Spurs, chrome —
- No. 338R for 20" — No. 340R for 22" ... 10.95
- 1 set KNOBBY Tom Tom Legs, chrome —
- No. 275R for 16" — No. 276R for 14" ... 22.50
- 1—No. 249R—KNOBBY Shell-Mount Cymbal Holder, chrome ... 8.25
- for mounting cymbal on floor tom tom
- 1—No. 325R—SWIV-O-MATIC Extension Cymbal Arm, chrome ... 5.50
- 1—No. 320R—SWIV-O-MATIC Cymbal Tilter, chrome ... 4.50
- 1—No. 398—Rocket Foot Pedal ... 25.00
- 1—No. 1725C—Cymbal Floor Stand, chrome ... 9.95
- 1—No. 1716C—Drum Stand, chrome ... 10.50
- 1—No. 1729C—Hi-Hat Sock Pedal, chrome ... 21.50
- 1—No. 4788—Cow Bell ... 2.25
- 1—No. 280R—Adjustable Cowbell Holder, chrome ... 4.50
- 1—No. 288R—Stick Holder Assembly, chrome ... 11.50
- 1 pr. No. R-2A—Drum Sticks ... 1.20
- 1 pr. No. 943RC—Wire Brushes ... 1.75

CYMBALS FOR "TOP-HAT" OUTFITS

No. 4312 "AVEDIS ZILDJIAN" CYMBAL ASSORTMENT **\$180^{40B}**

- TAX PAID
- No. 4340M—(2) 14 in. Hi-Hat, Medium @ \$29.708 ... \$59.408
- No. 4332M—(1) 20 in. Medium ... 55.008
- No. 4334M—(1) 22 in. Medium ... 66.008

No. 4356 "PASHA" CYMBAL ASSORTMENT **\$136⁰⁰**

- TAX PAID
- No. 4265—(2) 14 in. Hi-Hat, Medium @ \$15.75 ... \$31.50
- No. 4268—(1) 20 in. Medium ... 41.00
- No. 4269—(1) 22 in. Medium ... 63.50

See Listing on Cymbal Pages for Other Sizes



"PARKLANE" COCKTAIL OUTFITS

IN RADIANT PEARL AND DELUXE CHROME
PLASTIC HEADS, UNLESS OTHERWISE SPECIFIED

No. 1880 - OUTFIT

Total List Value \$390.20

AS ILLUSTRATED

SPECIFY CHOICE OF PEARL

INCLUDES THESE DRUMS AND ACCESSORIES:

- 1—No. 59—HOLIDAY 16 x 16 TOM TOM, choice of pearl \$96.00
- 1—No. 53—HOLIDAY 9 x 13 TOM TOM, choice of pearl 76.50
- 1—No. 25—HOLIDAY 5 x 14 SNARE DRUM, choice of pearl 99.00

WITHOUT CYMBALS

\$377.50

TAX
PAID

No. 1881 - OUTFIT

Total List Value \$387.70

AS ILLUSTRATED

BUT IN THIS COMBINATION OF SIZES:

- 1—No. 59—HOLIDAY 16 x 16 TOM TOM, choice of pearl \$96.00
- 1—No. 51—HOLIDAY 8 x 12 TOM TOM, choice of pearl 74.00
- 1—No. 25—HOLIDAY 5 x 14 SNARE DRUM, choice of pearl 99.00

WITHOUT CYMBALS

\$375.00

TAX
PAID

ACCESSORIES FOR "PARKLANE" COCKTAIL OUTFITS NOS. 1880 . . . 1881

- 1 set No. 275R—KNOBBY Tom Tom Legs, chrome \$22.50
- 2—No. 382R—SWIV-O-MATIC All Purpose Holders, chrome @ \$19.75 39.50
for mounting of snare drum and small tom-tom.
- 1—No. 325R—SWIV-O-MATIC Cymbal Extension Arm, chrome 5.50
- 1—No. 320R—SWIV-O-MATIC Cymbal Tilter, chrome 4.50
- 1—No. 205R—Upbeat Foot Pedal 22.50
- 1—No. 249R—KNOBBY Shell-mount Cymbal Holder, chrome 8.25
- 1—No. 4787—Cow Bell 2.25
- 1—No. 4789—Cow Bell 2.50
- 1—No. 237R—Trap Rack (for mounting cowbells) chrome 8.25
- 1 pr. No. 943RC—Wire Brushes 1.75
- 1 pr. No. R-2A—Drum Sticks 1.20

CYMBALS FOR "PARKLANE" COCKTAIL OUTFITS

- No. 4328M—"AVEDIS ZILDJIAN" CYMBAL, 16 in. Medium \$36.30B
- No. 4266—"PASHA" CYMBAL, 16 in. Medium 22.00

See Listing on Cymbal Pages for Other Sizes

"ASTORIA" COCKTAIL OUTFITS

IN RADIANT PEARL AND DELUXE CHROME
PLASTIC HEADS, UNLESS OTHERWISE SPECIFIED

No. 1882 - OUTFIT

Total List Value \$277.40

AS ILLUSTRATED:
SPECIFY CHOICE OF PEARL

\$270.00

TAX
PAID

INCLUDES THESE DRUMS AND ACCESSORIES:

- 1—No. 59—HOLIDAY 16 x 16 TOM TOM, choice of pearl \$96.00
- 1—No. 25—HOLIDAY 5 x 14 SNARE DRUM, choice of pearl 99.00

ACCESSORIES FOR "ASTORIA" COCKTAIL OUTFITS

- 1 set No. 275R—KNOBBY Tom Tom Legs, chrome \$22.50
- 1—No. 382R—SWIV-O-MATIC All-Purpose Holder, chrome 19.75
for mounting of snare drum
- 1—No. 249R—KNOBBY Shell-mount Cymbal Holder, chrome 8.25
- 1—No. 205R—Upbeat Foot Pedal 22.50
- 1—No. 280R—Adjustable Cowbell Holder Assembly, chrome 4.50
- 1—No. 4787—Cow Bell 1.95
- 1 pr. No. 943RC—Wire Brushes 1.75
- 1 pr. No. R-2A—Drum Sticks 1.20



No. 278R—\$10.00
COCKTAIL WHEEL
WITH LOCKING LEVER

Attaches to any
stand or hardware
tom-tom leg. For
effortless holding of
Cocktail Cymbal.

CYMBALS FOR "ASTORIA" COCKTAIL OUTFITS

- No. 4328M—"AVEDIS ZILDJIAN" CYMBAL, 16 in. Medium \$36.30B
- No. 4266—"PASHA" CYMBAL, 16 in. Medium 22.00

See Listing on Cymbal Pages for Other Sizes



ACCESSORIES FOR "COMET" OUTFITS

Nos. 1885 . . . 1886

1—No. 360R—SWIV-O-MATIC Tom Tom Holder, chrome	\$19.75
1—No. 331R—Internal Cymbal Holder, chrome	8.00
1—No. 320R—SWIV-O-MATIC Cymbal Tilting, chrome	4.50
1 pr. Internal Spurs, chrome — No. 338R for 20" — No. 340R for 22"	10.95
1—No. 1716C—Drum Stand, chrome	10.50
1—No. 399—Jet Foot Pedal	19.50
1—No. 478B—Cow Bell	2.25
1—No. 4656—Cowbell Holder, chrome	3.00
1 pr. No. 943RC—Wire Brushes	1.75
1 pr. No. R-5A—Drum Sticks	1.20

"VIDEO" OUTFITS

IN LACQUER FINISH AND DELUXE CHROME
PLASTIC HEADS, UNLESS OTHERWISE SPECIFIED

No. 1905 - OUTFIT

Total List Value \$282.15

AS ILLUSTRATED

Choice of Lacquer Finish:

White — Black — Blue & Silver — Black & Gold

INCLUDES THESE DRUMS AND ACCESSORIES:

1—No. 72—TOWER 14 x 20 Separate Tension BASS DRUM, choice of lacquer color	\$95.50
1—No. 14—LUXOR 5 x 14 SNARE DRUM, choice of lacquer color	59.50
1—No. 42—TOWER 8 x 12 Separate Tension TOM TOM, choice of lacquer color	55.00

No. 1906 - OUTFIT

Total List Value \$289.15

AS ILLUSTRATED, BUT IN

THIS COMBINATION OF SIZES:

1—No. 74—TOWER 14 x 22 Separate Tension BASS DRUM, choice of lacquer color	\$100.00
1—No. 14—LUXOR 5 x 14 SNARE DRUM, choice of lacquer color	59.50
1—No. 44—TOWER 9 x 13 Separate Tension TOM TOM, choice of lacquer color	57.50

CYMBALS FOR "VIDEO" OUTFITS

No. 4326M—"AYEDIS ZILDJIAN" CYMBAL, 14 in. Medium \$29.708
No. 4265—"PASHA" CYMBAL, 14 in. Medium 15.75

See Listing on Cymbal Pages for Other Sizes

"COMET" OUTFITS

IN RADIANT PEARL AND DELUXE CHROME
PLASTIC HEADS, UNLESS OTHERWISE SPECIFIED

No. 1885 - OUTFIT

Total List Value \$341.90

AS ILLUSTRATED

SPECIFY CHOICE OF PEARL

INCLUDES THESE DRUMS AND ACCESSORIES:

1—No. 73—TOWER 14 x 20 Separate Tension BASS DRUM, choice of pearl	\$128.50
1—No. 15—LUXOR 5 x 14 SNARE DRUM, choice of pearl	49.50
1—No. 43—TOWER 8 x 12 Separate Tension TOM TOM, choice of pearl	62.50

WITHOUT CYMBALS
\$332.50
TAX PAID

No. 1886 - OUTFIT

Total List Value \$348.90

AS ILLUSTRATED, BUT IN

THIS COMBINATION OF SIZES:

1—No. 75—TOWER 14 x 22 Separate Tension BASS DRUM, choice of pearl	\$132.00
1—No. 15—LUXOR 5 x 14 SNARE DRUM, choice of pearl	49.50
1—No. 45—TOWER 9 x 13 Separate Tension TOM TOM, choice of pearl	65.00

WITHOUT CYMBALS
\$337.50
TAX PAID

CYMBALS FOR "COMET" OUTFITS

No. 4326M—"AYEDIS ZILDJIAN" CYMBAL, 14 in. Medium \$29.708
No. 4265—"PASHA" CYMBAL, 14 in. Medium 15.75

See Listing on Cymbal Pages for Other Sizes



ACCESSORIES FOR "VIDEO" OUTFITS

Nos. 1905 . . . 1906

1 pr. Internal Spurs, chrome — No. 338R for 20" — No. 340R for 22"	\$10.95
1—No. 331R—Internal Cymbal Holder, chrome	8.00
1—No. 345R—SWIV-O-MATIC Hoop Mount Tom Tom Holder, chrome	15.00
1—No. 399—Jet Foot Pedal	19.50
1—No. 478B—Cow Bell	2.25
1—No. 4656—Cowbell Holder, chrome	3.00
1—No. 1716C—Drum Stand, chrome	10.50
1 pr. No. 943RC—Wire Brushes	1.75
1 pr. No. R-2A—Drum Sticks	1.20



ACCESSORIES FOR "LUXOR" OUTFITS

Nos. 1910 . . . 1911 . . . 1912 . . . 1913

1 pr. No. 338R—Internal Spurs, chrome	\$10.95
1—No. 331R—Internal Cymbal Holder, chrome	8.00
1—No. 264R—KNOBBY Tom Tom Holder, chrome	9.75
1—No. 4441—Champ Foot Pedal	9.75
1—No. 4816R—Wood Block	2.50
1—No. 4805C—Wood Block Holder, chrome	1.20
1—No. 4787—Cow Bell	2.25
1—No. 4656—Cowbell Holder, chrome	3.00
1—No. 525—Drum Stand, Nickel	6.95
1 pr. No. 943RC—Wire Brushes	1.75
1 pr. No. R-5A—Drum Sticks	1.20
1—No. 4302—Pasha Cymbal, 11 in. Thin	7.00

"BANDSTAND" OUTFITS

IN LACQUER FINISH AND DELUXE CHROME
PLASTIC HEADS, UNLESS OTHERWISE SPECIFIED

No. 1900 - OUTFIT

Total List Value \$363.90

AS ILLUSTRATED

Choice of Lacquer Finishes:

White — Black — Blue & Silver — Black & Gold

INCLUDES THESE DRUMS AND ACCESSORIES:

1—No. 72—TOWER 14 x 20 Separate Tension BASS DRUM, choice of lacquer color	\$95.50
1—No. 18—TOWER 5 x 14 SNARE DRUM, choice of lacquer color	72.00
1—No. 42—TOWER 8 x 12 Separate Tension TOM TOM, choice of lacquer color	55.00
1—No. 46—TOWER 12 x 15 Separate Tension TOM TOM, choice of lacquer color	59.50

No. 1902 - OUTFIT

Same as No. 1900, but in CHOICE OF PEARL

No. 1901 - OUTFIT

Total List Value \$370.90

AS ILLUSTRATED, BUT IN

THIS COMBINATION OF SIZES:

1—No. 74—TOWER 14 x 22 Separate Tension BASS DRUM, choice of lacquer color	\$100.00
1—No. 18—TOWER 5 x 14 SNARE DRUM, choice of lacquer color	72.00
1—No. 44—TOWER 9 x 13 Separate Tension TOM TOM, choice of lacquer color	57.50
1—No. 46—TOWER 12 x 15 Separate Tension TOM TOM, choice of lacquer color	59.50

No. 1903 - OUTFIT

Same as 1901, but in CHOICE OF PEARL

"LUXOR" OUTFITS

IN LACQUER FINISH AND DELUXE CHROME
PLASTIC HEADS, UNLESS OTHERWISE SPECIFIED

No. 1910 - OUTFIT

Total List Value \$248.30

AS ILLUSTRATED—With Cymbal

Choice of Lacquer Finishes:

White • Black • Blue & Silver • Black & Gold

INCLUDES THESE DRUMS AND ACCESSORIES:

1—No. 14—LUXOR 5 x 14 SNARE DRUM, choice of lacquer color	\$59.50
1—No. 40—LUXOR 8 x 12 Single Head TOM TOM, choice of lacquer color	39.50
1—No. 62—MERCURY 14 x 20 Single Tension BASS DRUM, choice of lacquer color	85.00

WITH CYMBAL

\$240⁰⁰
TAX PAID

No. 1912 - OUTFIT

Same as No. 1910, but in CHOICE OF PEARL

\$290⁰⁰
TAX PAID

No. 1911 - OUTFIT

Total List Value \$263.80

AS ILLUSTRATED, BUT WITH

DOUBLE HEAD TOM TOM

1—No. 14—LUXOR 5 x 14 SNARE DRUM, choice of lacquer color	\$59.50
1—No. 42—TOWER 8 x 12 Separate Tension TOM TOM, choice of lacquer color	55.00
1—No. 62—MERCURY 14 x 20 Single Tension BASS DRUM, choice of lacquer color	85.00

WITH CYMBAL
\$255⁰⁰
TAX PAID

No. 1913 - OUTFIT

Same as No. 1911, but in CHOICE OF PEARL

\$305⁰⁰
TAX PAID



ACCESSORIES FOR "BANDSTAND" OUTFITS

Nos. 1900 . . . 1901 . . . 1902 . . . 1904

1 pr. Internal Spurs, chrome — No. 338R for 20" — No. 340R for 22"	\$10.95
1—No. 331R—Internal Cymbal Holder, chrome	8.00
1 set No. 4256—Flare Tom Tom Legs, chrome	9.75
1—No. 345R—SWIV-O-MATIC Hoop Mount Tom Tom Holder, chrome	15.00
1—No. 399—Jet Foot Pedal	19.50
1—No. 1716C—Drum Stand, chrome	10.50
1—No. 4788—Cow Bell	2.25
1—No. 4656—Cowbell Holder, chrome	3.00
1 pr. No. 943RC—Wire Brushes	1.75
1 pr. No. R-2A—Drum Sticks	1.20

CYMBALS FOR "BANDSTAND" OUTFITS

No. 4326M—"AVEDIS ZILDJIAN" CYMBAL, 14 in. Medium	\$29.700
No. 4265—"PASHA" CYMBAL, 14 in. Medium	15.75

See Listing on Cymbal Pages for Other Sizes

"CLIPPER" OUTFITS

IN LACQUER FINISH AND DELUXE CHROME
PLASTIC HEADS, UNLESS OTHERWISE SPECIFIED

No. 1915 - OUTFIT

Total List Value \$199.05

Choice of Lacquer Colors,

White — Black — Blue & Silver — Black & Gold

WITH CYMBAL
\$195.00
TAX PAID

No. 1916 - OUTFIT

Total List Value \$241.05

Same as above, but in CHOICE OF PEARL

WITH CYMBAL
\$237.50
TAX PAID

- | | |
|---|---------|
| 1 No. 14—LUXOR 5 x 14 SNARE DRUM,
choice of lacquer color | \$59.00 |
| 1 No. 62—MERCURY 14 x 20 Single Tension BASS DRUM,
choice of lacquer color | 85.00 |
| 1 No. 331R—Internal Cymbal Holder, chrome | 8.00 |
| 1 pr. No. 338R—Internal Spurs, chrome | 18.95 |
| 1—No. 4441—Champ Foot Pedal | 9.75 |
| 1—No. 4816R—Wood Block | 2.50 |
| 1—No. 4805C—Wood Block Holder, chrome | 1.20 |
| 1 No. 4787—Cow Bell | 2.25 |
| 1—No. 4656—Cowbell Holder, chrome | 3.00 |
| 1—No. 525—Drum Stand, nickel | 6.95 |
| 1—No. 943RC—Wire Brushes | 1.75 |
| 1 pr. No. R-5A—Drum Sticks | 1.20 |
| 1 No. 4302—Pasha Cymbal, 11 in. Thin | 7.00 |



"CLASSMATE" OUTFITS

IN LACQUER FINISH AND DELUXE CHROME

PLASTIC HEADS, UNLESS OTHERWISE SPECIFIED

No. 1920 - OUTFIT

Total List Value \$149.00

Choice of Lacquer Colors,

White — Black — Blue & Silver — Black & Gold

WITH CYMBAL
\$145.00
TAX PAID

- | | |
|---|---------|
| 1—No. 10—CLASSMATE 4 x 13 Single Tension SNARE DRUM,
choice of lacquer color | \$32.50 |
| 1—No. 60—CLASSMATE 14 x 20 Single Tension BASS DRUM,
choice of lacquer color | 80.00 |
| 1 No. 4441—Champ Foot Pedal | 9.75 |
| 1 pr. No. 4413—Spurs, chrome | 3.75 |
| 1—No. 532—Drum Stand, nickel | 5.50 |
| 1—No. 1452R—Cymbal Holder, nickel | 2.85 |
| 1—No. 4787—Cow Bell | 1.95 |
| 1—No. 4656—Cow Bell Holder, chrome | 3.00 |
| 1 pr. No. 943—Wire Brushes | 1.50 |
| 1 pr. No. R-5A—Drum Sticks | 1.20 |
| 1—Elementary Drum Book | 1.00 |
| 1—No. 4301—Pasha Cymbal, 10 in. Thin | 6.00 |



PHOTOGRAPHS

Glossy photos of our star drummers are available. Send 10c to partially cover mailing expense for each 8 x 10 photo.



• ROGERS • DRUM KITS

FOR STUDIO . . . SCHOOL . . . HOME

A practical way to start building, step by step, a complete ROGERS Drum *Outfit*



• ROGERS • PRE-DRUM KIT

No. 1590—Regular \$14.15 value,
Specially priced **\$13.50** TAX PAID

CONSISTS OF:

- No. RP-4—Weather King, 10" Practice Pad \$6.95
- No. 8988—Windsor Music Case 6.00
- No. R-4A—Drum Sticks pair 1.20

• BANNER • DRUM KIT

Chrome-Plated

No. 1591—Choice of Mahogany Finish or Lacquer. Regular \$57.70 value, Specially priced **\$55.00** TAX PAID

CONSISTS OF:

- No. 12—"Banner" 5" x 14" Single Tension Snare Drum \$45.00
- No. F49R—Fibre Carrying Case 7.50B
- No. 100—Drum Stand, nickel 4.00
- No. R-4A—Drum Sticks pair 1.20

BANNER "PEARL"

1592—Banner "Pearl" Drum Kit. Same as above but with No. 13 Banner Snare Drum, Choice of Pearl. Regular \$62.20 value, Specially priced **\$59.50** TAX PAID



No. 1592 Banner "Pearl" Kit \$59.50

• LUXOR • DRUM KIT

Chrome-Plated

No. 1593—Choice of Mahogany or Lacquer. Regular \$75.15 value, specially priced **\$69.50** TAX PAID

CONSISTS OF:

- No. 14—Luxor 5 x 14 Snare Drum \$59.50
- No. F49R—Fibre Carrying Case 7.50B
- No. 525—Drum Stand, nickel 6.95
- No. R-4A—Drum Sticks pair 1.20

LUXOR "PEARL"

1594—Luxor "Pearl" Drum Kit. Same as above, but with No. 15 Luxor Snare Drum, Choice of Pearl. Regular \$86.15 value, Specially priced **\$79.50** TAX PAID



No. 1593 Luxor "Multi-Color" Kit \$69.50

• TOWER • DRUM KIT

Chrome-Plated

No. 1596—Choice of Mahogany or Lacquer. Regular \$93.45 value, specially priced **\$89.50** TAX PAID

CONSISTS OF:

- No. 18—Tower 5x14 Snare Drum \$72.00
- No. 1716C—Drum Stand, chrome 10.50
- No. F49R—Fibre Carrying Case 7.50B
- No. 7396—Practice Pad 2.25
- No. R-4A—Drum Sticks pair 1.20

1597—TOWER "MAHOGANY" DRUM KIT. Same as above, but with No. 990 Hard-Shell Case. Regular \$105.45 value, Specially priced **\$99.50** TAX PAID

1598—Tower "Pearl" Drum Kit. Same as above, but with No. 19 Tower Snare Drum, Choice of Pearl and No. 990 Hard-Shell Case. Regular \$115.45 value, Specially priced **\$109.50** TAX PAID



No. 1597 Tower "Mahogany" Kit \$99.50

PLASTIC HEADS SUPPLIED ON ALL DRUMS, UNLESS OTHERWISE SPECIFIED.

• ROGERS • DELUXE DRUM KITS

HOLIDAY "PEARL" DRUM KIT

Chrome-Plated

No. 1599—Choice of Pearl, Regular \$150.15 value, Specially priced **TAX PAID \$139.50**

CONSISTS OF:

No. 25—Holiday 5 x 14 Snare Drum \$99.00
 No. 983—Deluxe Hard-Shell Leather-Bound Carrying Case, plush lined 29.50
 No. 1716C—Drum Stand, chrome 10.50
 No. 7396—Practice Pad 2.25
 No. 943—Wire Brushes pair 1.50
 No. R-4A—Drum Sticks pair 1.20
 No. 1002—Jim Chapin "You're on Drums" Record 6.20B

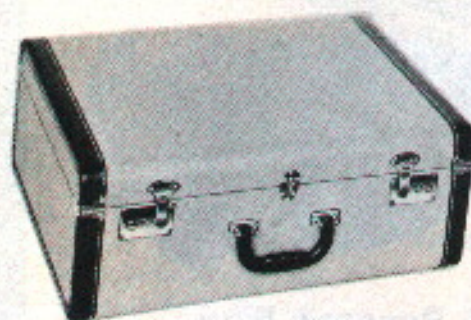

• PAGEANT • PARADE DRUM KIT

Chrome-Plated

No. 1585—Mahogany Finish, Regular \$67.00 value, Specially priced **TAX PAID \$64.50**

CONSISTS OF:

No. 1510—Pageant 10" x 14" Separate Tension Parade Drum (6 Center Lugs) \$59.50
 No. F14R—Fibre Carrying Case 7.50B
 No. 1586—Pageant "Pearl" Drum Kit. Same as above, but with No. 1511 Pageant Parade Drum, Choice of Pearl. Regular \$81.00 value, Specially priced **TAX PAID \$78.50**

• LEXINGTON • PARADE DRUM KIT

Chrome-Plated

No. 1580—Mahogany Finish, Regular \$52.50 value, Specially priced **TAX PAID \$50.00**

CONSISTS OF:

No. 1500—Lexington 10" x 14" Single Tension Parade Drum \$45.00
 No. F14R—Fibre Carrying Case 7.50B
 No. 1581—Same as above, but with Waterproof Zipper Carrying Bag (in place of fibre case) **TAX PAID \$50.00**

• CAMBRIDGE • PARADE DRUM KIT

Chrome-Plated

No. 1587—Genuine Mahogany or Lacquer, Regular \$82.50 value, Specially priced **TAX PAID \$79.50**

CONSISTS OF:

No. 1520—Cambridge 10" x 14" Separate Tension Parade Drum (8 Center Lugs — Triple Flange Hoops) \$75.00
 No. F14R—Fibre Carrying Case 7.50B
 No. 1588—Cambridge "Pearl" Drum Kit. Same as above, but with No. 1521 Cambridge Parade Drum, Choice of Pearl. Regular \$95.50 value, Specially priced **TAX PAID \$92.50**

• NEWPORT • PARADE DRUM KIT

Chrome-Plated

No. 1582—Genuine Mahogany or Lacquer, Regular \$67.00 value, Specially priced **TAX PAID \$54.50**

CONSISTS OF:

No. 1505—Newport 10" x 14" Single Tension Parade Drum (8 rods) \$49.50
 No. F14R—Fibre Carrying Case 7.50B
 No. 1583—Same as above, but with Waterproof Zipper Carrying Bag (in place of fibre case) **TAX PAID \$54.50**

PLASTIC HEADS SUPPLIED ON ALL DRUMS, UNLESS OTHERWISE SPECIFIED.

dyna-sonic...

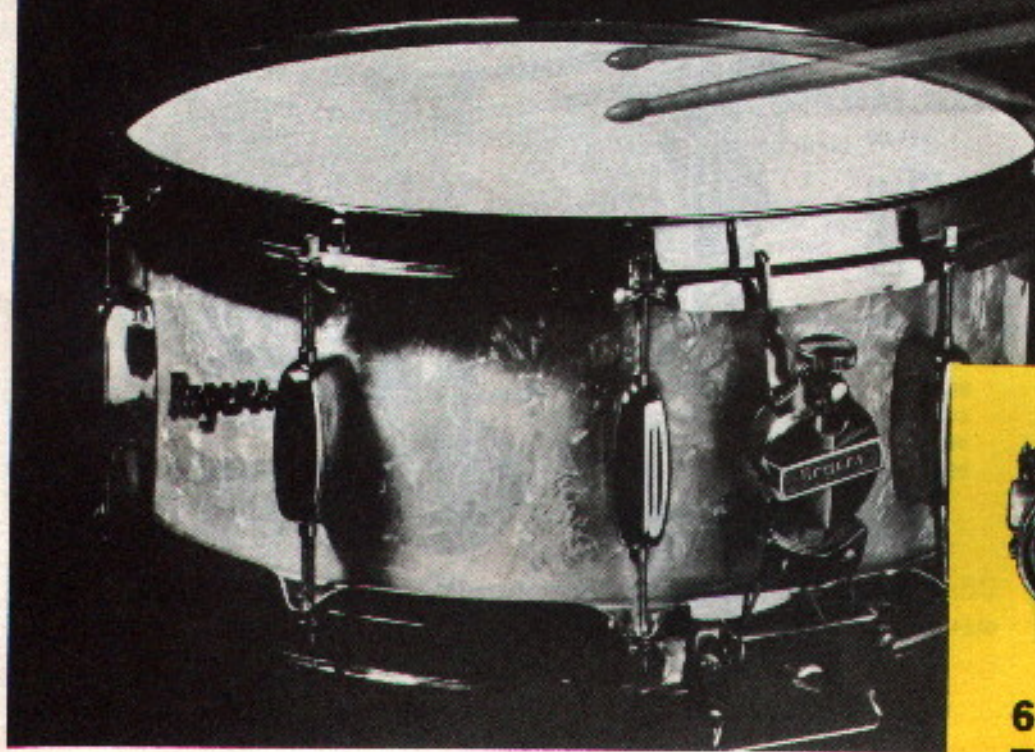

• DYNA-SONIC • PEARL SNARE DRUMS

CUSTOM-BUILT SHELLS — FLOATING SNARES

- 10 Self-Aligning Lugs
- Swiv-a-matic Strainer
- Triple Flange Hoops
- Polished Chrome Fittings
- Custom-Built Construction
- Pinpoint Definition
- Power without Distortion
- Choke-Free Sound
- Perfect Feel
- Complete Head Response



No.	TAX PAID
32—5" x 14", choice of pearl	\$150.00
33—6 1/2" x 14", choice of pearl	152.50
35—8" x 15", choice of pearl	155.00

With Internal Tone Control, Unless Otherwise Specified

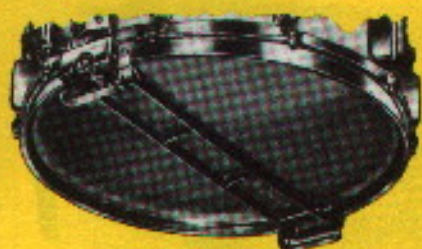

6 Reasons Why This New Drum Will Improve Your Playing

1. **Pinpoint Definition** . . . power without distortion. Your snares ride with the snare head. They're always in position for your fastest stroke. There's never a snare slap. You hear each beat—even at full power—crisp and clean, never running together.
2. **Choke-Free Sound** . . . the revolutionary floating snares eliminate distortion completely. The snare frame holds the snares in perfect alignment and in full contact with the snare head. You get instant response over the entire head area. The choking nightmare disappears because snares can be tightly tensioned without pressure against snare head.
3. **Perfect Feel** . . . you enjoy increased stick rebound and added speed with half the effort. A natural result when each component of the drum is working in precise, coordinated relationship. Never before has a snare head been able to respond so freely—in perfect coordination—to the batter head. You can feel it in the way your sticks fly off the head. The head feels solid, not mushy.
4. **Full Power** . . . the unrestricted coordinated vibration of heads and snares gives you full power and response with less effort—over the entire head area. There are no dead spots. Your sound projects easily—from double pianissimo to triple fortissimo. Always with sharply defined snare action. Always without distortion. Always crisp.
5. **The Sound of Music** . . . this drum has true musical sound. The tone quality is beautiful. The drum sings. This comes from the new matched relationship in weight and measurement between floating snares, heads, custom-processed shell and other components.
6. **Simplest Adjustment** . . . You get the simplicity of one-point uniform tension adjustment. A single tension screw does it. The new snare frame doubles as a protective guard for the snares.

• DYNA-SONIC • "METAL SHELL" SNARE DRUM

•
Custom
Built
Shells
•

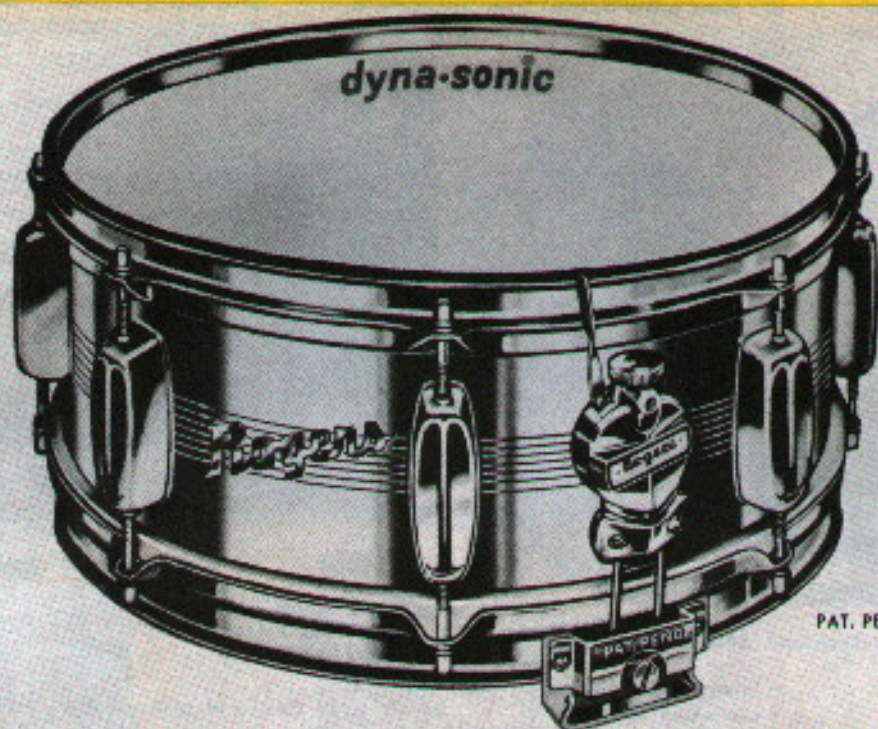

•
Dyna-Sonic
Floating
Snares
•

PAT. PEND.

NEW FLOATING SNARES that give you ONE-POINT UNIFORM TENSION ADJUSTMENT

- 10 Self-Aligning Lugs
- Swiv-a-matic Strainer
- Triple Flange Hoops
- Polished Chrome Fittings
- Custom-Built Construction

No.	TAX PAID
36—5" x 14", All Metal Shell, Deluxe chrome plated	\$150.00
37—6 1/2" x 14", All Metal Shell, Deluxe chrome plated	152.50

- Pinpoint Definition
- Power without Distortion
- Choke-Free Sound
- Perfect Feel
- Complete Head Response

With Internal Tone Control, Unless Otherwise Specified

• HOLIDAY • "PERMA-BUILT" SNARE DRUMS



- 8 Self-Aligning Lugs
- 20 Strand Snappy Snares
- Swiv-a-matic Strainer
- Polished Chrome Fittings

- Separate Tension
- Triple Flange Hoops
- Solid Maple Reinforcing Rings
- Internal Tone Control

No.	TAX PAID
28—5" x 14", All Metal Shell, Deluxe Chrome Plated	\$ 99.00
29—6 1/2" x 14", All Metal Shell, Deluxe Chrome Plated	102.00

No.	TAX PAID
24—5" x 14", Choice of Mahog. or Lacquer	\$ 89.00
25—5" x 14", Choice of Pearl	99.00
26—6 1/2" x 14", Choice of Mahog or Lacquer	92.00
27—6 1/2" x 14", Choice of Pearl	102.00

PLASTIC HEADS SUPPLIED ON ALL DRUMS, UNLESS OTHERWISE SPECIFIED

PEARL FINISHES: Choice of 13 Radiant Colors • LACQUER FINISHES: White . . . Black . . . Blue & Silver . . . Black & Gold

ROGERS "PERMA-BUILT" SNARE DRUMS



• CENTURY • CONCERT DRUMS

with SWIV-O-MATIC "Perma-Tension" SNARE STRAINER

- Chrome Plated Fittings
- Deluxe Triple Flange Hoops
- 20 Strand Snappy Snares
- Internal Tone Control
- Laminated Shells
- Maple Reinforcing Rings
- 16 Self-Aligning Lugs

No.		TAX PAID
20—8" x 15"	Choice of Mahogany or Lacquer	\$ 95.00
21—8" x 15"	Choice of Pearl	105.00
	Gut Snares Add \$2.00	

• LUXOR • MODEL

- Chrome Plated Fittings
- Deluxe Triple Flange Hoops
- 6 Self-Aligning Lugs
- 16 Strand Snappy Snares
- Laminated Shells
- Maple Reinforcing Rings

No.		TAX PAID
14—5" x 14"	Choice of Mahogany or Lacquer	\$59.50
15—5" x 14"	Choice of Pearl	69.50
16—6 1/2" x 14"	Choice of Mahogany or Lacquer	62.50
17—6 1/2" x 14"	Choice of Pearl	72.50
	Internal Tone Control Add \$3.75	



• BANNER • MODEL

- Chrome Plated Fittings
- Single Tension
- 6 Rods — Center Supports
- "L" Flange Hoops
- 12 Strand Snappy Snares
- Throw-Off Strainer
- Laminated Shells
- Maple Reinforcing Rings

No.		TAX PAID
12—5" x 14"	Single Tension, Choice of Mahogany Finish or Lacquer	\$45.00
13—5" x 14"	Single Tension, choice of Pearl	49.50



• TOWER • MODEL

- Chrome Plated Fittings
- Deluxe Triple Flange Hoops
- 8 Self-Aligning Lugs
- 16 Strand Snappy Snares
- Laminated Shells
- Maple Reinforcing Rings

No.		TAX PAID
18—5" x 14"	Choice of Mahogany or Lacquer	\$72.00
19—5" x 14"	Choice of Pearl	82.00
20—6 1/2" x 14"	Choice of Mahogany or Lacquer	74.00
21—6 1/2" x 14"	Choice of Pearl	84.00
22—6 1/2" x 15"	Choice of Mahogany or Lacquer	78.00
23—6 1/2" x 15"	Choice of Pearl	88.00
	Internal Tone Control Add \$3.75	



• CLASSMATE • JUNIOR

- Chrome Plated Fittings
- Single Tension
- 6 Rods — Center Supports
- "L" Flange Hoops
- Silk Wire-Wound Snares
- Adjustable Strainer
- Laminated Shells
- Maple Reinforcing Rings

No.		TAX PAID
10—4" x 13"	Single Tension, choice of Mahogany Finish or Lacquer	\$32.50

PEARL FINISHES: Choice of 13 Radiant Colors • LACQUER FINISHES: White . . . Black . . . Blue & Silver . . . Black & Gold

PLASTIC HEADS SUPPLIED ON ALL DRUMS, UNLESS OTHERWISE SPECIFIED

ROGERS "PERMA-BUILT" TOM-TOMS

PRICES LISTED ARE FOR
TOM-TOMS ONLY

SEE PAGES 52 and 53
FOR COMPLETE LISTING
OF TOM-TOM HOLDERS
and LEGS



• TOWER • MODEL

- Chrome Plated Fittings
- Separate Tension
- Triple Flange Hoops
- Laminated Shells
- Maple Reinforcing Rings
- Deluxe Finish

WITHOUT HOLDERS OR LEGS

No.	TAX PAID
40—8" x 12" Choice of Lacquer	\$55.00
41—8" x 12" Choice of Pearl	62.50
42—9" x 13" Choice of Lacquer	57.50
43—9" x 13" Choice of Pearl	65.00
44—12" x 15" Choice of Lacquer	59.50
45—12" x 15" Choice of Pearl	75.00
For Internal Tone Control	Add \$3.75

IMPORTANT

All Tom Toms are priced
WITHOUT holders or legs.
Be sure to specify which
holder or legs are desired.



• HOLIDAY • MODEL

- Chrome Plated Fittings
- Triple Flange Hoops
- Internal Tone Control
- 12 Self-Aligning Lugs
- Laminated Shells
- Maple Reinforcing Rings

WITHOUT HOLDERS

No.	TAX PAID
50—8" x 12" Choice of Lacquer	\$66.00
51—8" x 12" Choice of Pearl	74.00
52—9" x 13" Choice of Lacquer	68.50
53—9" x 13" Choice of Pearl	76.50



• LUXOR • MODELS "Single Head"

- Chrome Plated Fittings
- Triple Flange Hoops
- 6 Self-Aligning Lugs
- Laminated Shells
- Maple Reinforcing Rings

WITHOUT HOLDERS

No.	TAX PAID
46—8" x 12" Choice of Lacquer	\$39.50
47—8" x 12" Choice of Pearl	47.50



• HOLIDAY • FLOOR MODELS

- Chrome Plated Fittings
- Triple Flange Hoops
- Internal Tone Control
- 16 Self-Aligning Lugs
- Laminated Shells
- Maple Reinforcing Rings

WITHOUT LEGS

No.	TAX PAID
54—14" x 14" Choice of Lacquer	\$75.00
55—14" x 14" Choice of Pearl	88.50
56—16" x 14" Choice of Lacquer	77.50
57—16" x 14" Choice of Pearl	92.00
58—16" x 16" Choice of Lacquer	80.00
59—16" x 16" Choice of Pearl	96.00

IMPORTANT

All Tom Toms are priced
WITHOUT holders or legs.
Be sure to specify which
holder or legs are desired.

PLASTIC HEADS SUPPLIED ON ALL DRUMS, UNLESS OTHERWISE SPECIFIED

ROGERS "PERMA-BUILT" BASS DRUMS



PLASTIC HEADS SUPPLIED ON ALL DRUMS,
UNLESS OTHERWISE SPECIFIED



• HOLIDAY • BASS DRUMS

- Chrome Plated Fittings
- Self-Aligning Lugs
 - Laminated Shells
 - Maple Reinforcing Rings

No.	TAX PAID
84-12" x 20" Choice of Lacquer	\$100.00
85-12" x 20" Choice of Pearl	133.00
86-14" x 20" Choice of Lacquer	103.00
87-14" x 20" Choice of Pearl	136.00
88-12" x 22" Choice of Mahogany or Lacquer	107.00
89-12" x 22" Choice of Pearl	140.00
90-14" x 22" Choice of Mahogany or Lacquer	112.00
91-14" x 22" Choice of Pearl	145.00
92-14" x 24" Choice of Mahogany or Lacquer	123.00
93-14" x 24" Choice of Pearl	156.00
94-14" x 26" Choice of Mahogany or Lacquer	132.00
95-14" x 26" Choice of Pearl	165.00
96-14" x 28" Choice of Mahogany or Lacquer	136.50
97-14" x 28" Choice of Pearl	169.50

Pearl Inlaid Hoops Supplied on all Lacquer and Pearl Models

• TOWER • BASS DRUMS

SEPARATE TENSION

- Chrome Plated Fittings
- Center Self-Aligning Lugs
 - Laminated Shells
 - Maple Reinforcing Rings

No.	TAX PAID
72-14" x 20" Choice of Lacquer	\$ 95.50
73-14" x 20" Choice of Pearl	128.50
74-14" x 22" Choice of Mahogany or Lacquer	100.00
75-14" x 22" Choice of Pearl	133.00
76-14" x 24" Choice of Mahogany or Lacquer	112.00
77-14" x 24" Choice of Pearl	145.00
78-14" x 26" Choice of Mahogany or Lacquer	117.50
79-14" x 26" Choice of Pearl	150.00
80-14" x 28" Choice of Mahogany or Lacquer	122.50
81-14" x 28" Choice of Pearl	155.00

Pearl Inlaid Hoops Supplied on all Lacquer and Pearl Models

ROGERS "PERMA-BUILT" BASS DRUMS

• CONCERT • BASS DRUMS

- Chrome Plated Fittings
- Self-Aligning Lugs
- Laminated Shells
- Maple Reinforcing Rings

No.		TAX PAID
1700	14" x 30" Choice of Mahogany or Lacquer	\$150. ⁰⁰
1701	14" x 30" Choice of Pearl	182. ⁵⁰
1702	14" x 32" Choice of Mahogany or Lacquer	160. ⁰⁰
1703	14" x 32" Choice of Pearl	193. ⁰⁰
1704	16" x 30" Choice of Mahogany or Lacquer	154. ⁰⁰
1705	16" x 30" Choice of Pearl	187. ⁰⁰
1706	16" x 32" Choice of Mahogany or Lacquer	165. ⁰⁰
1707	16" x 32" Choice of Pearl	198. ⁰⁰
1708	16" x 34" Choice of Mahogany or Lacquer	175. ⁰⁰
1709	16" x 34" Choice of Pearl	208. ⁰⁰

Pearl Inlaid Hoops Supplied on all Lacquered and Pearl Models

PLASTIC HEADS SUPPLIED ON ALL DRUMS UP TO 30"
UNLESS OTHERWISE SPECIFIED

• MERCURY • BASS DRUMS

Single Tension

- Chrome Plated Fittings
- Streamlined Center Lug
- Laminated Shells
- Maple Reinforcing Rings

No.		TAX PAID
62	14" x 20" Choice of Lacquer	\$ 85. ⁰⁰
63	14" x 20" Choice of Pearl	117. ⁵⁰
64	14" x 22" Choice of Mahogany or Lacquer	94. ⁵⁰
65	14" x 22" Choice of Pearl	127. ⁵⁰
66	14" x 24" Choice of Mahogany or Lacquer	105. ⁰⁰
67	14" x 24" Choice of Pearl	137. ⁵⁰
68	14" x 26" Choice of Mahogany or Lacquer	110. ⁰⁰
69	14" x 26" Choice of Pearl	142. ⁵⁰
70	14" x 28" Choice of Mahogany or Lacquer	116. ⁵⁰
71	14" x 28" Choice of Pearl	149. ⁵⁰

For Pearl Inlaid Hoops on Lacquer Models Add \$5.00

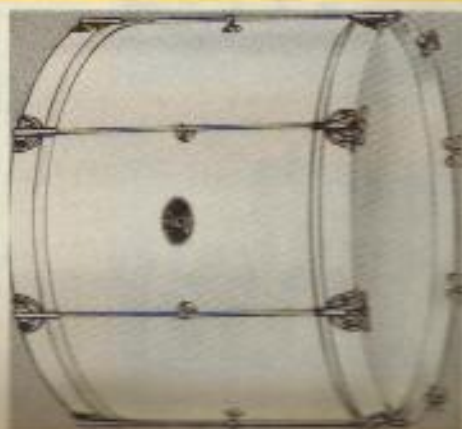

PEARL FINISHES: Choice of 13 Radiant Colors

LACQUER FINISHES: White, Black, Blue & Silver, Black & Gold

Other Colors Supplied on Special Order



• CLASSMATE • BASS DRUMS →

Single Tension . . . Chrome Plated Fittings
Modernistic Center Supports . . . Laminated Shells
Maple Reinforcing Rings

No. 60—14" x 20" Choice of Lacquer

TAX PAID
\$80.⁰⁰

Rogers



West High School—Columbus, Ohio
James Hill, Director



University of Dayton
Maurice R. Reichard, Director



Miller's Blackhawks—Dayton, Ohio
E. L. Randall, President



THE GOLDEN SABRES
Dayton, Ohio, C. W. Jones, Mgr.



RAY (RED) FLOYD
Ringling Bros. and
Barnum & Bailey Circus

dyna-sonic

trademark

the all-new custom-built drum with
the revolutionary FLOATING SNARES...

Rogers

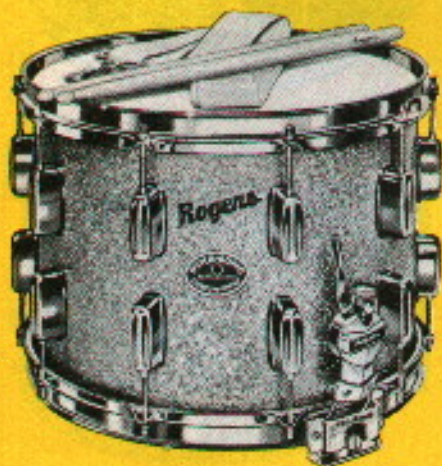

SHAKER HEIGHTS HIGH SCHOOL BAND
Shaker Heights, Ohio
Francis Hammond, Director

• DYNA-SONIC • MARCHING DRUMS

A NEW, REVOLUTIONARY CONCEPT

Rogers Advanced engineering has scored a breakthrough in drum manufacturing through an entirely new approach. The new scientifically designed "Floating Snares" and the specially treated shells are meticulously matched with other components, to produce the perfect sound and feel not possible with conventional models. The drum with a true musical sound.



SHATTERS ALL TRADITION

DYNA-SONIC gives you:

- Floating Snares with one-point tension adjustment.
- Full Head Response.
- Sensitivity at the slightest touch.
- Definition . . . power without distortion.
- Crispness and projection of sound, never before obtained in a drum.
- The perfect combination of "sound" and "feel".
- Custom-made construction throughout.

Swiv-a-matic Snare Strainer . . . Deluxe Triple Flange Hoops . . . 20 Dual Row Self-Aligning Lugs . . .
Chrome Plated Fittings . . . Solid Maple Reinforcing Rings . . . Sticks and Nylon Sling Included.

PLASTIC HEADS STANDARD, UNLESS OTHERWISE SPECIFIED

PEARL FINISHES: Choice of 13 Radiant Colors

LACQUER FINISHES: White, Black, Blue & Silver and Black & Gold
Other Colors Supplied on Special Order

• DYNA-SONIC • PARADE DRUMS

No	TAX PAID
1530—10" x 14" Mahog. or Lacquer	\$138.00
1531—10" x 14" Choice of Pearl	150.00
1532—12" x 15" Mahog. or Lacquer	145.00
1533—12" x 15" Choice of Pearl	160.00

Internal Tone Control Optional on Parade and Tenor Drums.

• DYNA-SONIC • TENOR DRUMS

No	TAX PAID
1570—12" x 15" Mahog. or Lacquer	\$110.00
1571—12" x 15" Choice of Pearl	125.00
1572—12" x 16" Mahog. or Lacquer	112.50
1573—12" x 16" Choice of Pearl	127.50

Pearl Inlaid Hoops, standard on Pearl Scotch Drums. On Lacquer Finishes add \$5.00

Prices INCLUDE Federal Excise Tax

• DYNA-SONIC • SCOTCH DRUMS

No	TAX PAID
1625—10" x 26" Mahog. or Lacquer	\$155.00
1626—10" x 26" Choice of Pearl	175.00
1627—10" x 28" Mahog. or Lacquer	165.00
1628—10" x 28" Choice of Pearl	185.00

Rogers



XAVIER UNIVERSITY BAND
Gilbert T. Maninger, Director

• CAMBRIDGE • MARCHING DRUMS

PLASTIC HEADS STANDARD, UNLESS OTHERWISE SPECIFIED

- Genuine Mahogany Laminated Shells
- Separate Tension
- Throw-off Strainer
- Deluxe Triple Flange Hoops
- Sticks and Sling Included
- Solid Maple Reinforcing Rings
- 8 Center Self-Aligning Lugs
- 16 Strand Snappy Snares
- Chrome Plated Fittings

PEARL FINISHES: Choice of 13 Radiant Colors

LACQUER FINISHES: White, Black, Blue & Silver and Black & Gold
Other Colors Supplied on Special Order

• CAMBRIDGE • PARADE DRUMS

No.	TAX PAID
1520—10" x 14" Mahog. or Lacquer	\$ 75.00
1521—10" x 14" Choice of Pearl	88.00
1522—12" x 15" Mahog. or Lacquer	86.50
1523—12" x 15" Choice of Pearl	103.00

Gut Snares Add \$2.00
Internal Tone Control Add 3.75

• CAMBRIDGE • TENOR DRUMS

No.	TAX PAID
1560—12" x 15" Mahog. or Lacquer	\$ 86.50
1561—12" x 15" Choice of Pearl	103.00
1562—12" x 16" Mahog. or Lacquer	87.50
1563—12" x 16" Choice of Pearl	104.00

Pearl Inlaid Counter Hoops, standard on Pearl Scotch Drums. On Lacquer Finishes add \$5.00.

Prices INCLUDE Federal Excise Tax

• CONCORD • SCOTCH DRUMS

No.	TAX PAID
1605—8" x 26" Mahog. or Lacquer	\$115.00
1606—8" x 26" Choice of Pearl	137.00
1607—10" x 26" Mahog. or Lacquer	117.50
1608—10" x 26" Choice of Pearl	139.50
1610—8" x 28" Mahog. or Lacquer	125.00
1611—8" x 28" Choice of Pearl	147.00
1612—10" x 28" Mahog. or Lacquer	127.50
1613—10" x 28" Choice of Pearl	149.50



VIRGINIA STATE COLLEGE

Dr. F. Nathaniel Gatlin, Director • Mr. Claiborne Richardson, Asst. Director



EL ZARIBAH TEMPLE GUARD • Phoenix, Arizona • W. Cecil Armstrong, Director

Rogers



UNIVERSITY OF LOUISVILLE,
Leon Raper, Director

• YORKTOWN • MARCHING DRUMS

PLASTIC HEADS STANDARD, UNLESS OTHERWISE SPECIFIED

- Genuine Mahogany Laminated Shells
- Separate Tension
- Swiv-a-matic Snare Strainer
- Deluxe Triple Flange Hoops
- Internal Tone Control
- Solid Maple Reinforcing Rings
- 16 Dual-Row Self-Aligning Lugs
- 20 Strand Snappy Snares
- Chrome Plated Fittings
- Sticks and Nylon Sling Included

PEARL FINISHES: Choice of 13 Radiant Colors

LACQUER FINISHES: White, Black, Blue & Silver and Black & Gold
Other Colors Supplied on Special Order

• YORKTOWN • PARADE DRUMS

No.	TAX PAID
1525—10" x 14" Mahog. or Lacquer	\$ 82.00
1526—10" x 14" Choice of Pearl	95.00
1527—12" x 15" Mahog. or Lacquer	91.00
1528—12" x 15" Choice of Pearl	107.50

Gut Snares Add \$2.00

• YORKTOWN • TENOR DRUMS

No.	TAX PAID
1565—12" x 15" Mahog. or Lacquer	\$ 91.00
1566—12" x 15" Choice of Pearl	107.50
1567—12" x 16" Mahog. or Lacquer	92.00
1568—12" x 16" Choice of Pearl	108.50

Pearl Inlaid Counter Hoops, standard on Pearl Scotch Drums. On Lacquer Finishes Add \$5.00.

Prices INCLUDE Federal Excise Tax

• YORKTOWN • SCOTCH DRUMS

No.	TAX PAID
1620—10" x 26" Mahog. or Lacquer	\$123.00
1621—10" x 26" Choice of Pearl	145.00
1622—10" x 28" Mahog. or Lacquer	133.00
1623—10" x 28" Choice of Pearl	155.00



WASHINGTON STATE UNIVERSITY

Mr. Randall Spicer, Director of Bands • Mr. Howard Deming, Marching Band Director



NOTRE DAME "Fling Irish" MARCHING BAND • Robert F. O'Brien, Director

ROGERS INC. • 744 Bolivar Rd. • CLEVELAND 15, OHIO

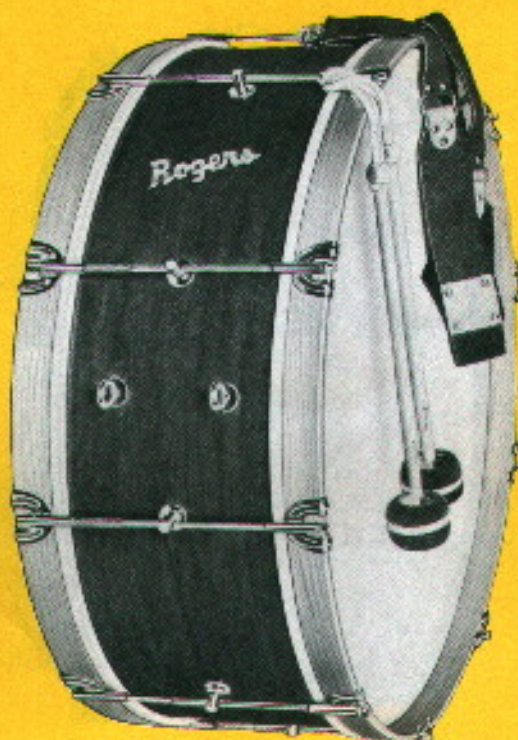

CLEVELAND HEIGHTS HIGH SCHOOL BAND
Cleveland Hts., Ohio
John F. Farinacci, Director

• NEWPORT • MARCHING DRUMS

PLASTIC HEADS STANDARD, UNLESS OTHERWISE SPECIFIED

- Genuine Mahogany Laminated Shells
- Single Tension
- Throw-Off Strainer
- Chrome Plated Fittings
- Solid Maple Reinforcing Rings
- 8 Rods
- 12 Strand Snappy Snares
- Sticks and Sling Included

PEARL FINISHES: Choice of 13 Radiant Colors

LACQUER FINISHES: White, Black, Blue & Silver and Black & Gold
Other Colors Supplied on Special Order

• NEWPORT • PARADE DRUMS

No.	TAX PAID
1505—10" x 14" Mahog. or Lacquer	\$ 49.50
1506—10" x 14" Choice of Pearl	62.50
1507—12" x 15" Mahog. or Lacquer	57.50
1508—12" x 15" Choice of Pearl	74.00

Gut Snares Add \$2.00
Internal Tone Control Add 3.75

• NEWPORT • TENOR DRUMS

No.	TAX PAID
1550—12" x 15" Mahog. or Lacquer	\$ 57.50
1551—12" x 15" Choice of Pearl	74.00
1552—12" x 16" Mahog. or Lacquer	60.00
1553—12" x 16" Choice of Pearl	76.50

Pearl Inlaid Counter Hoops, standard on all Pearl Models.
On Lacquer Finishes add: \$2.50 for Parade and Tenor . . . \$5.00 for Scotch Drums.
Prices INCLUDE Federal Excise Tax

• NEWPORT • SCOTCH DRUMS

No.	TAX PAID
1600—8" x 26" Mahog. or Lacquer	\$ 89.50
1601—8" x 26" Choice of Pearl	111.50
1602—10" x 26" Mahog. or Lacquer	92.50
1603—10" x 26" Choice of Pearl	114.50

• LEXINGTON • PARADE DRUMS

PLASTIC HEADS STANDARD, UNLESS OTHERWISE SPECIFIED

- 6 Rods
- Solid Maple Reinforcing Rings
- 12 Strand Snappy Snares
- Sticks and Sling Included
- Single Tension
- Laminated Shells
- Throw-off Strainer
- Chrome Plated Fittings

No. 1500—10" x 14" Mahogany Finish	TAX PAID
	\$45.00

Available in Lacquer Finishes on Special Order at Same Price.

Gut Snares Add \$2.00
Internal Tone Control Add 3.75



Rogers

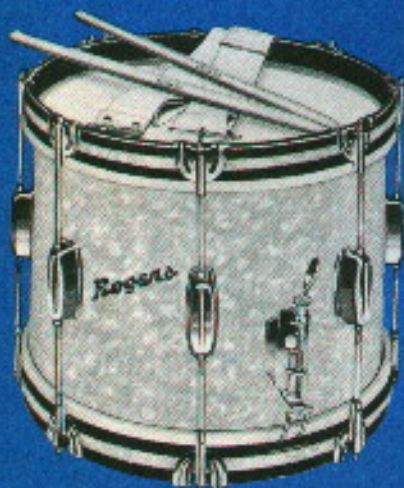

CARNEGIE TECH KILTIE BAND • Pittsburgh, Penna.

• CONCORD • MARCHING DRUMS

PLASTIC HEADS STANDARD, UNLESS OTHERWISE SPECIFIED

- Genuine Mahogany Laminated Shells
- Separate Tension
- Throw-off Strainer
- Chrome Plated Fittings
- Solid Maple Reinforcing Rings
- 8 Center Self-Aligning Lugs
- 16 Strand Snappy Snares
- Sticks and Sling Included

PEARL FINISHES: Choice of 13 Radiant Colors

LACQUER FINISHES: White, Black, Blue & Silver and Black & Gold
Other Colors Supplied on Special Order

• CONCORD • PARADE DRUMS

No.	TAX PAID
1515—10" x 14" Mahog. or Lacquer	\$ 69.50
1516—10" x 14" Choice of Pearl	82.50
1517—12" x 15" Mahog. or Lacquer	80.00
1518—12" x 15" Choice of Pearl	96.50

Gut Snares Add \$2.00
Internal Tone Control Add \$3.75

• CONCORD • TENOR DRUMS

No.	TAX PAID
1555—12" x 15" Mahog. or Lacquer	\$ 80.00
1556—12" x 15" Choice of Pearl	96.50
1557—12" x 16" Mahog. or Lacquer	82.50
1558—12" x 16" Choice of Pearl	99.00

Pearl Inlaid Counter Hoops, standard on all Pearl Models.
On Lacquer Finishes add: \$2.50 for Parade and Tenor.
\$5.00 for Scotch Drums.

Prices INCLUDE Federal Excise Tax

• CONCORD • SCOTCH DRUMS

No.	TAX PAID
1605—8" x 26" Mahog. or Lacquer	\$115.00
1606—8" x 26" Choice of Pearl	137.00
1607—10" x 26" Mahog. or Lacquer	117.50
1608—10" x 26" Choice of Pearl	139.50
1610—8" x 28" Mahog. or Lacquer	125.00
1611—8" x 28" Choice of Pearl	147.00
1612—10" x 28" Mahog. or Lacquer	127.50
1613—10" x 28" Choice of Pearl	149.50



• PAGEANT • PARADE DRUMS

PLASTIC HEADS STANDARD, UNLESS OTHERWISE SPECIFIED

Separate Tension in the economy price range. Professional features usually found only on higher priced models. Rogers superb workmanship throughout.

- Separate Tension
- Laminated Shells
- Throw-off Strainer
- Chrome Plated Fittings
- 6 Center Self-Aligning Lugs
- Solid Maple Reinforcing Rings
- 16 Strand Snappy Snares
- Sticks and Sling Included

No.	TAX PAID
No. 1510—10" x 14" Mahogany Finish Available in Lacquer Finishes on Special Order at Same Price	\$59.50
No. 1511—10" x 14" Choice of Pearl with Inlaid Counter Hoops	\$73.50

BELL LYRAS (GLOCKENSPIELS)

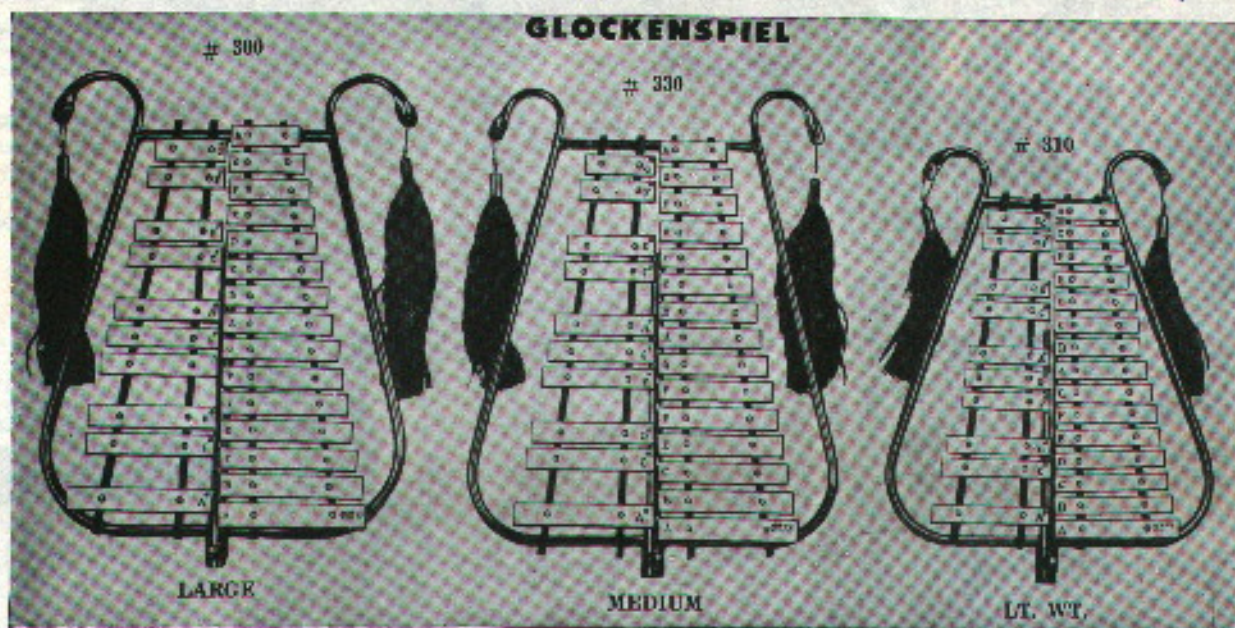

"EL CAPITAN" REGULAR WEIGHT

No. 300—Fed. Tax Paid..... \$135.00
Regular Glockenspiel 25 aluminum alloy bars, 1 1/4"x3/4". Chrome tubular frame. Countersunk holes with lock nuts on back for adjusting volume. Height over all, 28 inches. Width at widest point 21 inches. Weight 12 lbs. Complete with bag, holster belt, one mallet and plumes.

"DRESS PARADE" MEDIUM WEIGHT

No. 330—Fed. Tax Paid..... \$117.00
Tubular chrome frame, 25 bar regular Glockenspiel with 1 1/4"x3/4" bars. Countersunk holes with lock nuts on back for adjusting volume. Height over all 28", width at widest point 21". Weight 10 1/2 lbs. Complete with bag, holster belt, one mallet and plumes.

"AMERICAN PATROL" LIGHT WEIGHT

No. 310—Fed. Tax Paid..... \$96.50
Tubular chrome frame, 25 bar regular Glockenspiel, 1"x3/4" aluminum alloy bars. Countersunk holes with lock nuts on back for adjusting volume. Height over all 24 1/2", width at widest point 17". Weight 7 lbs. Complete with bag, holster belt, one mallet and plumes.

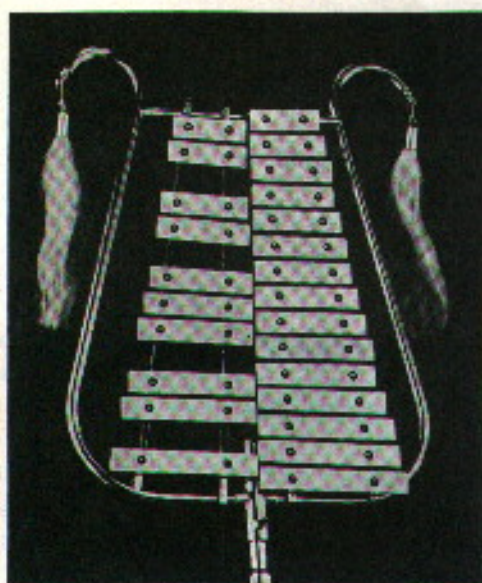

"STUDENT" MEDIUM GLOCKENSPIEL

No. 305—Fed. Tax Paid \$85.00

Made with 3/8" light steel tubular frame with baked on finish. Wide thin bars. Large size but light weight. Ideal for Girls in Band to carry. Outfit consists of rubberized snap fastener bag, holster belt, and mallet, white Nylon Plumes only



Nos. 4858-59



Nos. 4853-54-55

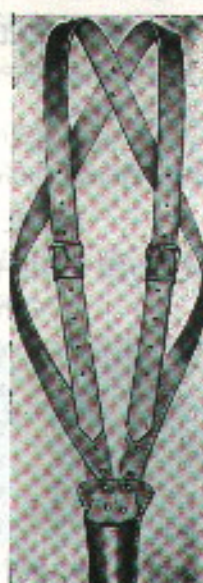

Nos. 4856-4857

• ROGERS • HEAVY WEBBING LYRA CARRIER

Fully adjustable, with leather pouch. Individually cellophane wrapped, 1 dozen to the box.

No. 4858—Khaki } Each \$5.50
No. 4859—White }

• ROGERS • LEATHER LYRA CARRIER

Top grain leather, single neck loop, full adjustable. Individually cellophane wrapped. 1 dozen to the box.

No. 4853—Russet } Each \$9.00
No. 4854—Black }
No. 4855—White } \$12.50

• ROGERS •

DOUBLE SHOULDER HARNESS LYRA CARRIER

Top-grain leather, fully adjustable, individually cellophane wrapped, one-half dozen to the box.

No. 4856—Russet Each \$11.50
No. 4857—White Each 15.00



• HOLDWELL • GLOCKENSPIEL STANDS (Stand Only)

Holdwell stand for any size Glockenspiel. Fits at any angle, good for vertical or horizontal position. Folds compactly.

No. 1477—(Stand only) Nickel. Each .. \$18.00

No. 1477C—Holdwell Stand, Chromium Plated. Each.... \$21.00

SPECIAL GLOCKENSPIELS

On definite order, we supply Glockenspiels in B₃, Alto Glockenspiels and Bugle Lyras also available on special order. Please allow reasonable delivery time.

GLOCKENSPIEL ACCESSORIES

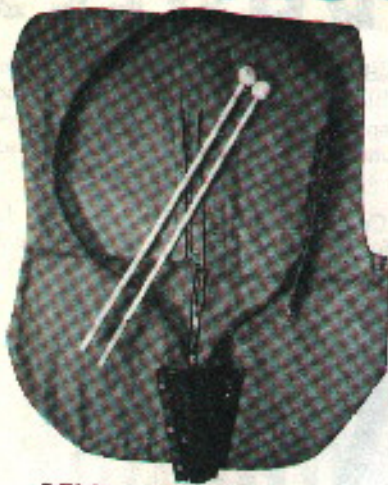

BELL LYRA COVERS
With Zipper

No. 4863—Glockenspiel Cover, made from heavy durable material. For Light Weight model Glockenspiel
Each \$9.00

No. 4864—Cover for Regular Glockenspiel Each 9.00

No. 4862—Glockenspiel Plumes.
Per Pair \$4.15

No. 4866—Repair Kit for Glockenspiel, includes screws, rubber washers, lock washers, hex nuts, and felt strips to repair two Glockenspiels. 1 Lt. Wt. and 1 Regular. Sold only as 1 unit.
Each \$12.50

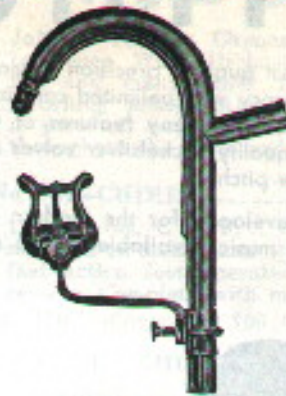

No. 4865 Lyre

GLOCKENSPIEL ACCESSORIES

No. 4869—Glockenspiel Lyre, as above with $\frac{3}{8}$ " hinged ring
Each \$5.00

No. 4865—Lyre $\frac{3}{8}$ " ring—To be attached to one side of tubular Glockenspiel.
Light Weight Each \$5.00



• ELTON • MALLETS

No. 265—Plastic handles with plastic balls Pair \$2.65

No. 266—Plastic handles with rubber balls Pair 2.50



Harness Shown
Without
Glockenspiel



GLOCKENSPIEL HARNESS

Bell Lyra Not Included

Enables player to use both hands while marching. Made with padded metal shoulder bands and metal casting receiver for Glockenspiel.

No. 4844—For 1" shaft \$25.00B

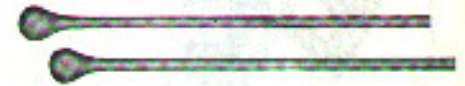

NYLON ONE-PIECE BELL-LYRA MALLETS

Moulded from one-piece solid nylon plastic. New material not affected by heat or cold. No handle or ball to come loose. Gives clear, brilliant tone to Bell-Lyra.

No. 1740R— Pair \$3.00

BUGLES, FIFES and ACCESSORIES



• REXCRAFT • PROFESSIONAL BUGLE

U. S. Regulation. Professional style, made of heavy brass, polished; large turned rim. In key of G with slide to F. Made in U. S. A.

No. 1193—Professional Bugle Each \$15.50

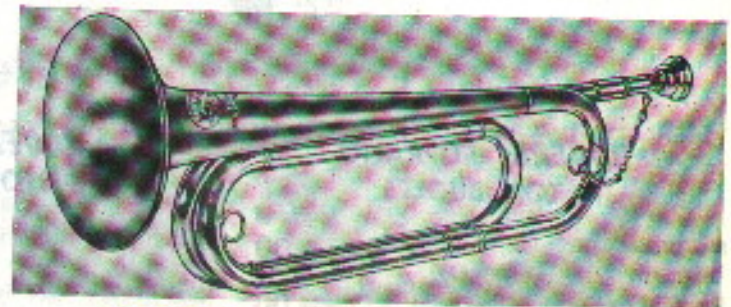

• ROGERS • U. S. REGULATION BUGLES

Made in U. S. A.

The ideal U. S. Regulation Model Bugle for Scouts, Schools, Camps, Junior Drum and Bugle Corps. Sturdily built, in brass, highly polished finish, with nickel-plated mouthpiece and chain, broad bell rim and two hooks for chain or bugle cord. Key of G with slide to F. Bell diameter $4\frac{1}{8}$ ", length with mouthpiece $17\frac{3}{4}$ ". Rogers Eagle design on bell.

1200R—Brass, polished, Tax Paid, Each \$13.50

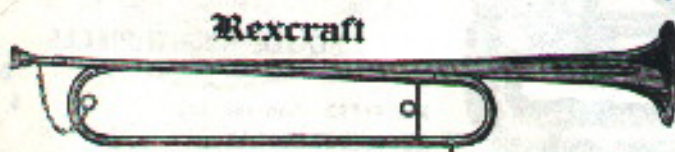

LEGION MODEL BUGLE

Key of G—Slide to F. 28 Inches Long

No. 1191—Legion Bugle Each \$26.40

THIS MODEL SUPPLIED ON SPECIAL ORDER ONLY.
MUST HAVE 2 TO 3 WEEKS TIME FOR DELIVERY.

BUGLE BAGS

No. 1250—Regulation, Mackintosh Each \$2.55
No. 1249—Legion 28", Mackintosh 3.30



BUGLE MOUTHPIECES

No. 240—Hercu, Rhodium Plated Each \$2.00
No. 1398—Sani-Clear, transparent plastic Each .70



• AMERICAN • FIFE

Made of brass tube, heavily nickel-plated. Metal lip plate. Ideal for drum corps.

No. 4215—Key of C, Nickel-plated Each \$2.45
No. 4216—Key of B \flat , Nickel-plated Each 2.55

• ROGERS • PISTON BUGLES

ROGERS PISTON BUGLES are instruments of the very finest quality, precision engineered from selected materials. They have been developed to produce a tone of the utmost brightness and brilliancy with unlimited carrying power. Ease of blowing, accurate intonation, absence of harsh tones and correctness of design are but a few of the many features of these fine instruments, which can be attributed to the excellence of materials and precision workmanship. Finest quality Nickelsilver valves or pistons are ground and re-ground by hand to assure long life and easy, satisfactory action. Built in standard low pitch.

Modern design, easy blowing Bugles which have been developed for the modern Drum and Bugle Corps, enabling it to obtain the full tonal color, depth and resonance so necessary to martial music. Available in five models, allowing full range and depth to be given to outstanding Drum and Bugle Corps arrangements.

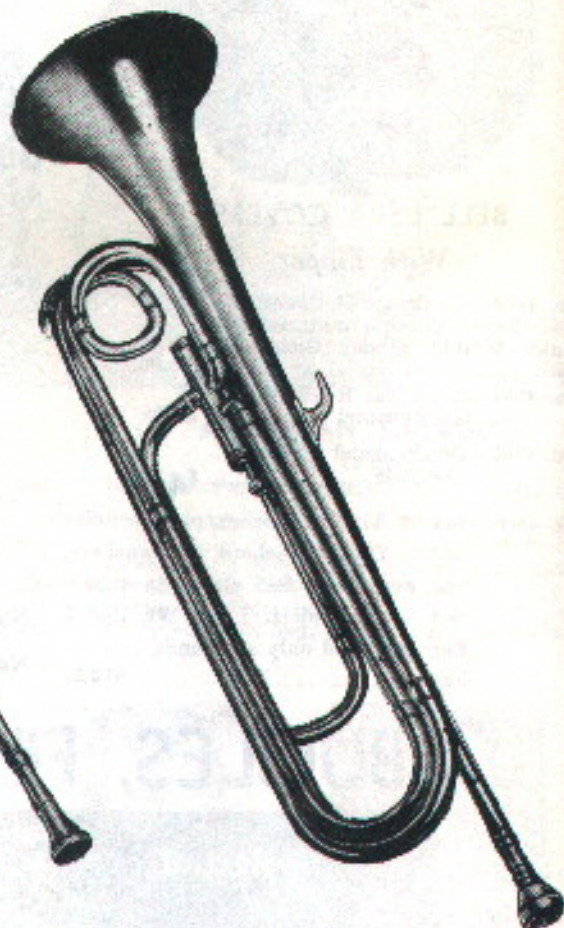

• ROGERS • SOPRANO PISTON BUGLES

	Tax Included
No. F1501—Chromium, Key of G, Piston change to D, Slide to F	\$110.00
No. F1503—Chromium, Key of Bb, Piston change to F	110.00

• ROGERS • TENOR PISTON BUGLES

	Tax Included
No. F1505—Chromium, Key of G, Piston change to D, Slide to F	\$120.00
No. F1507—Chromium, Key of Bb Piston change to F	120.00

• ROGERS • BARITONE PISTON BUGLES

	Tax Included
No. F1509—Chromium, Key of G, Piston change to D, Slide to F	\$175.00
No. F1511—Chromium, Key of Bb, Piston change to F	175.00

ROTARY SLIDE ATTACHMENTS

Developed to give the Piston Bugle a full chromatic scale. A quick acting key lowers the pitch one full tone and springs back to open position when released. With the ever increasing range and abilities of the Drum and Bugle Corps of today, this is indeed a most progressive and welcome advancement.

CHROMIUM ROTARY

No. F1522—Soprano	}	\$55.00
No. F1523—Tenor		
No. F1524—Baritone		\$60.00

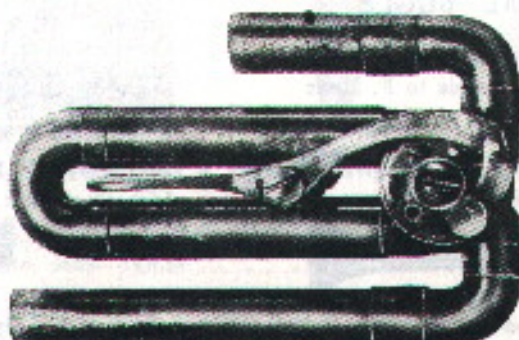

Rotary for Soprano and Tenor Bugles

BUGLE CASES — Plush Lined

	Each
No. F1517—Soprano Bugle Case	\$15.00
No. F1518—Tenor Bugle Case	17.50
No. F1519—Baritone Bugle Case	20.00

BUGLE MOUTHPIECES

	Each
No. F1532—Soprano Bugle	\$ 3.00
No. F1533—Tenor Bugle	3.00
No. F1534—Baritone Bugle	5.25

ROGERS PISTON BUGLES are supplied on a Special Order, Non-Cancellable, Non-Returnable basis. They are available in all finishes with Chrome finish being the standard. Single samples or sets are available on a trial basis. For complete information, write for details.

TUBULAR CHIMES

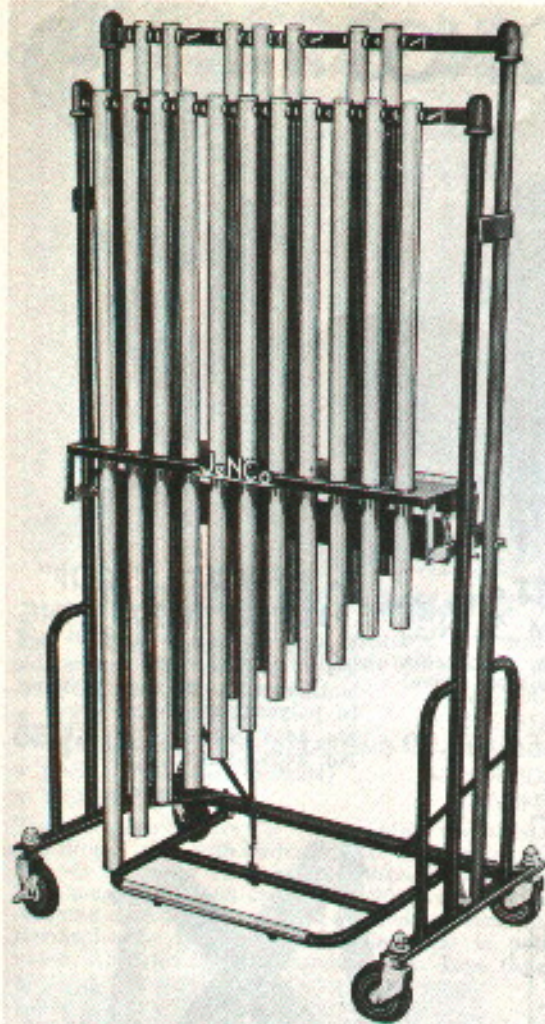

JeN-Co Tubular Chimes are used by the Lawrence Welk Orchestra, Richard Maltby, and many other fine musicians and recording artists. Also JeN-Co Chimes are a part of dozens of High School Bands throughout the USA and Canada.

No. 700—CHIMES Tax Paid **\$496.00B**

1½ octaves, C to F. 1" Chrome Plated tubes mounted on steel frame with wrinkle finish. Has fast action foot operated damper, and is on casters. Complete with mallet.

No. 700C—Cover for 700 Chimes **\$20.00**

No. LL5709—CHIMES Tax Paid **\$715.00B**

1½ octaves, 1½" Chrome Plated tubes. Mounted on tubular steel frame in black wrinkle finish. Instrument is on casters (2 with brake). Mallet furnished.

No. 709C—Cover for LL5709 Chimes **\$25.00**

No. 708—CHIMES Tax Paid **\$605.00B**

1½" chrome plated tubes. Tubular steel frame, same design as No. 5709 with wrinkled lacquer finish. Instrument is mounted on casters and has easy action foot operated damped pedal. Complete with mallet.

No. 708C—Cover for 708 Chimes **\$25.00**

CHIME BANNERS

The name of your school or organization can be displayed with a felt banner for tubular chimes. Available in choice of background colors with 4" or 8" letters, complete with back for attaching to the frame of the chimes. (Extra charge if more than 10 letters are used in the banner.)

On positive order, non-returnable basis only.

No. 1002 Each **\$30.00F**

CHIME BANNER



CHIMES LYRE

Made with ¾" Hinge Ring that can be attached along the side of the instrument. Highly Polished Nickel finish.

No. 645 Each **\$5.00**

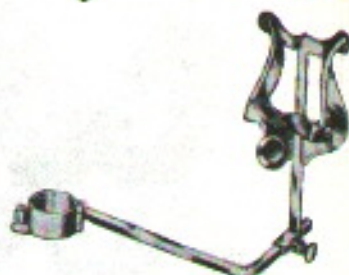

CHIME MALLETS

Balanced Hickory handles. Wrapped with heavy rawhide.

No. CM1—4 oz. **\$5.00**

No. CM2—6 oz. **\$5.50**



JeN-Co ROTARY TYMPANI

A NEW INNOVATION IN MACHINE TUNED KETTLE DRUMS WITH GAUGES



Light weight 1-piece Spun Kettles—25" and 28"—Wt. 68 lbs. pair. Copper lacquered—Small Plate under drum is sturdy casting.

Inside mechanism "spiders" pull up heads when turned clockwise to correct marking. Tuning can be set and locked in position to prevent meddling when not in use. Each tymp has full octave tuning range. Uniformity of tone over entire range of drum.

NO HANDLES
NO FOOT PEDALS
ADJUSTABLE TRIPOD

LEGS HAVE RUBBER TIPS
GOOD STRONG HEADS

No. 1000—Per pair, complete with Fibre Head Protectors and 1 pair mallets **\$588.50B**

No. X1005—Waterproof Covers, Set of 2 **\$21.00B**

Fed. Tax Paid

No guesswork tuning—Tuning is accomplished by simply turning the whole kettle and watching the indicators on top of the hoop.

Simple and Accurate Wide Range Tuning with Sound Scale Indicator plainly marked on rim of Tympani. This instrument was used in Europe for many years and is now in America for the first time.



• ROGERS • WEB SLINGS



• ROGERS • "DELUXE" PARADE DRUM SLING

Fully adjustable, extra heavy swivel hook. 2" wide webbing. In polyethylene bag.

No. 4447—White Ea. \$2.25

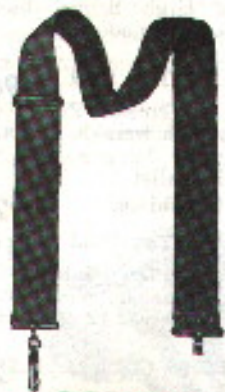

• ROGERS • "STANDARD" PARADE DRUM SLING

Slide buckle for adjustment, durable swivel hook. 2" wide webbing. In polyethylene bag.

No. 4460—White Ea. \$2.00



• ROGERS • JUNIOR DRUM SLINGS

Heavy 1" webbing, adjustable for length, Nickel-plated, swivel hook and snap.

No. 4449—White Ea. \$1.00



• ROGERS • "LOOP" PARADE DRUM SLING

Double stitched leather pad, snap fastener on adjustable leather strap. 2" wide webbing. In polyethylene bag.

No. 4444—Khaki } Ea. \$1.50
No. 4445—White }



• ROGERS • STANDARD BASS DRUM SLINGS

Made of stout 2" wide webbing. Crosses at the back. Fastens to center and to two rods which prevent drum from tilting. Nickel trimmings. In polyethylene bag.

Each
No. 4451—White ----- \$3.00

• ROGERS • SAM BROWNE BELT MODEL SLING



Heavy-quality webbing. All-range adjustment. Waist belt support helps to distribute weight evenly.

No. 4464R—WHITE
Bass Drum Sling ----- Each 6.00



• ROGERS • HARNESS BASS DRUM SLING

Carries drum's weight on the back and shoulders. Made of heavy, wide white webbing. Adjustable. Nickel trimmings. The ideal parade sling. In polyethylene bag.

Each
No. 4453—White ----- \$4.95

• ROGERS • NYLON SLINGS STRONG — DURABLE — PRACTICAL

Made of white NYLON—finest material known for strength and durability. Practical, neat and sanitary. Adds zest and snap to any uniform. Will not stretch, slip, or shrink. Wipes clean in a jiffy with soap and water. Has tremendous appeal to Legion Drum and Bugle Corps, High School and College Bands, Community Bands, Boy Scouts, Girl Scouts, etc.

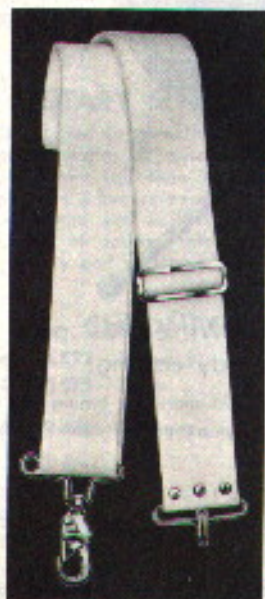

PARADE DRUM SLING

No. 4920
White NYLON in
Polyethylene
bags. Each

\$3.50

No. 4920

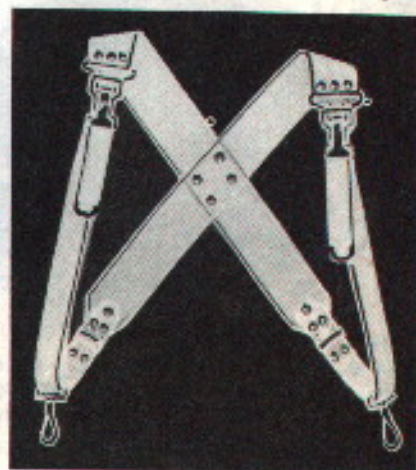

No. 4921

BASS DRUM HARNESS

No. 4921—White NYLON
In Polyethylene bag. Each \$6.50

•ROGERS• LEG RESTS, HI-STEPPER HOLDERS

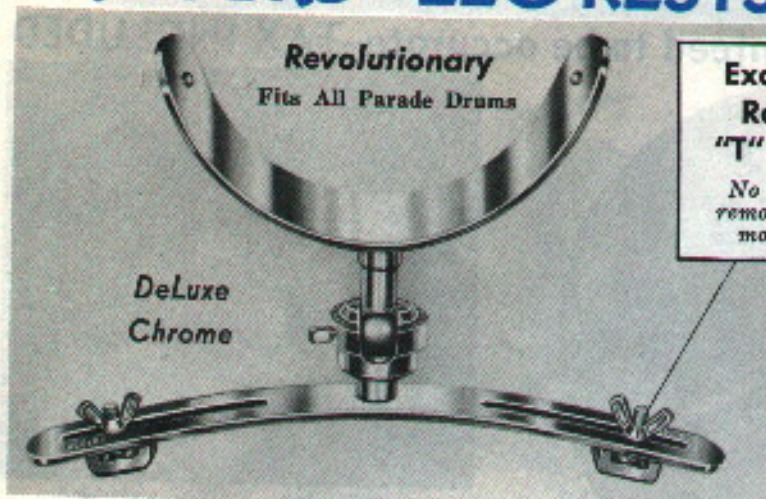

Exclusive Rogers "T" Clamp
No need to remove when mounting

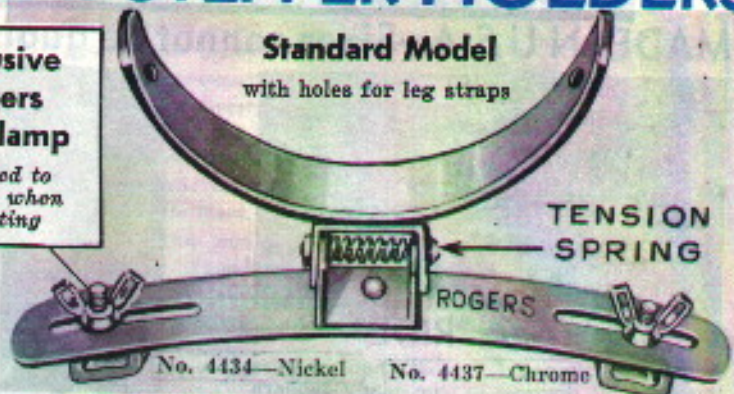

•ROGERS• SPRING-TENSION LEG REST

- No. 4434—Superior Model Leg Rest, polished, with Tension Spring, nickel plated Each \$4.80
- No. 4437—DeLuxe Model Leg Rest, polished, Chrome-plated, with Tension Spring Each 6.75

ROGERS • SWIV-O-MATIC® • LEG RESTS

No. 4677—Rod Mount—Most practical and most efficient leg rest ever designed. Individually boxed. Each \$7.50

- EXCLUSIVE "T" CLAMPS
- WIDE LEG BAND
- HOLES PERMIT LEG STRAPPING
- FAST, EASY ADJUSTMENT
- WISE-LIKE GRIP
- ALL-DIRECTIONAL
- USE STANDARD DRUM KEY
- HIGH GRADE STEEL
- INDIVIDUALLY BOXED
- PREVENTS SLIPPAGE

The exclusive Rogers "T" clamps slip over rods instantly without dismantling. Grips with bulldog tenacity. Nothing like it in all the world. Swiv-O-Matic leg rests have all directional ball and socket unit, with ball housing cut-out to permit 90° angle adjustment. Curved band mounted off-center for better fit and leg comfort. Revolutionary SWIV-O-MATIC leg rest is polished, chrome-plated, boxed. Adjusted by any standard key. Tops them all.



ROGERS • SWIV-O-MATIC® • SHELL MOUNT LEG REST

No. 4678—Polished and Chrome Plated \$7.50

General specifications and features are same as the rod-mount model shown above. Supplied with heavy steel plate, complete with bolts, nuts and washers.



•ROGERS• SPRING-TENSION SHELL MOUNT LEG REST

Same construction as No. 4437 rod-mount model, but equipped with large, rigid steel plate to fasten directly to shell. Supplied with bolts, nuts and washers.

No. 4678—Polished and Chrome-plated \$6.75



PADDED LEG RESTS

- Nickel Plated Finish
- No. 1695—Shell mount, with leg strap Each \$5.00
 - No. 1696—Rod mount, without leg strap 6.00
 - No. 1697—Rod mount, with leg strap 6.50

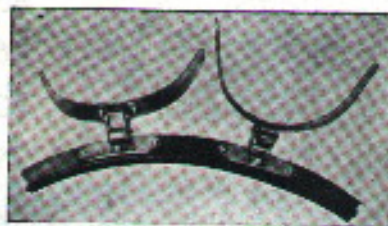

PARADE DRUM LEG RESTS

A practical attachment to hold parade drum in perfect position while marching.

No. 32—Perfection, adjustable and folding Each \$3.00

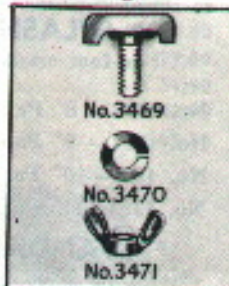

LEG REST ACCESSORIES

- Chrome Plated
- No. 3469—"T" Hook Clamp, flat-sided, threaded Each .50
 - No. 3470—Lock Washer Each .10
 - No. 3471—Wing Screw Each .15
 - No. 3472—Complete T-Hook Clamp Assembly75
 - No. 3473—Leather Thongs, 24" long, for leg strapping Pair .60

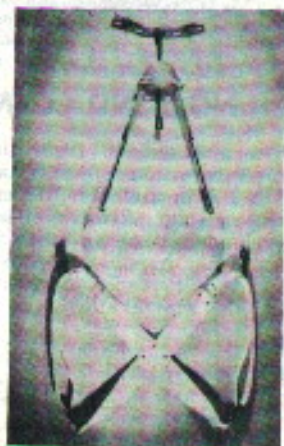

Patent Pending



•HI-STEPPER• HOLDER

No. 4198—For Parade or Tenor, Each \$29.95B

Extreme Maneuvers—Fast Turns, Spins, Counter Marches—Rear Backs, Forward, Back, Side Bends and Steps—Kneel, Sit, Run and Dance. An entirely new concept in carrying a Parade or Tenor Drum.

Topmost Performance Control—Speed Marching—Wind Resistant—No Bounce or Swing Around—No Body Bruises—Less Tiring—Weight Evenly Distributed — Precision Rudimental Playing.

No. 4199—Lyre, for Hi-Stepper, Each \$2.50

AVEDIS ZILDJIAN CYMBALS

MADE IN U.S.A.—Sizes cannot be guaranteed to be accurate—TAX INCLUDED



Be-Bop "RIDE"

A gradually tapered cymbal that answers the growing demand of the many modern drummers playing the "New Jazz".

No.	Size	Each, Tax Included
4343M	—18" Medium	\$44.00B
4345M	—20" Medium	55.00B
4347M	—22" Medium	66.00B

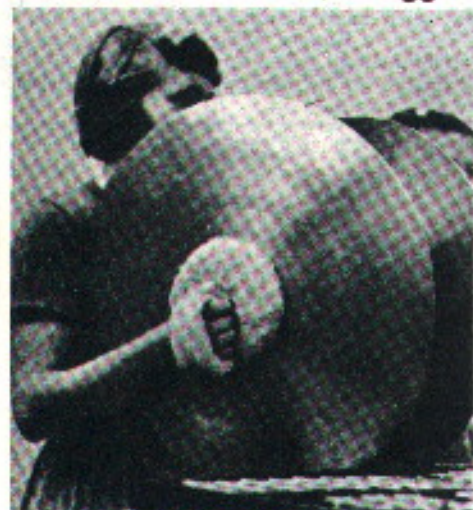

• AVEDIS ZILDJIAN •

• MARCHING BAND • CYMBALS

Select sizes and weight from listing as shown. Should be ordered in pairs, anywhere from 12" to 16" in diameter, depending on size and age group. Always order straps and pads (lamb's wool or leather recommended) or other handles. To fill requirements of various types of marching bands, these cymbals are available in suitable weights.

No.	Size	Each, Tax Included
No. M-12M	—12" Medium	\$22.00B
No. M-12MH	—12" Medium Heavy	
No. M-12H	—12" Heavy	
No. M-13M	—13" Medium	25.30B
No. M-13MH	—13" Medium Heavy	
No. M-13H	—13" Heavy	
No. M-14M	—14" Medium	29.70B
No. M-14MH	—14" Medium Heavy	
No. M-14H	—14" Heavy	
No. M-15M	—15" Medium	33.00B
No. M-15MH	—15" Medium Heavy	
No. M-15H	—15" Heavy	
No. M-16M	—16" Medium	36.30B
No. M-16MH	—16" Medium Heavy	

• CONCERT BAND • CYMBALS

Greater variety of tonal color, used primarily in large concert bands. Order by pair.

No.	Size	Each, Tax Included
No. C-17M	—17" Medium	\$40.70B
No. C-17MH	—17" Medium Heavy	
No. C-18M	—18" Medium	44.00B
No. C-18MH	—18" Medium Heavy	
No. C-20M	—20" Medium	55.00B
No. C-20MH	—20" Medium Heavy	



• SPLASH • CYMBALS

For fast crash (also called choke)

No.	Size	Each, Tax Included
No. 4320	—8" Paper Thin	\$ 8.80B
No. 4321	—9" Paper Thin	9.90B
No. 4322	—10" Paper Thin	16.50B
No. 4323	—11" Paper Thin	18.70B

• STANDARD • CYMBALS

Choice of sizes and weights, judged best for all-around work. This selection takes in "Crash" and "Crash-Ride" as well as "Show" and "Top", also "Bounce" dance Cymbals. Excellent selection of "Ride", medium "Ping" and "Hi-Hat" Cymbals.

4324PT	—12" Paper Thin	Tax Paid
4324T	—12" Thin	
4324M	—12" Medium	
4325PT	—13" Paper Thin	25.30B
4325T	—13" Thin	
4325M	—13" Medium	
4326PT	—14" Paper Thin	29.70B
4326T	—14" Thin	
4326M	—14" Medium	
4327T	—15" Thin	33.00B
4327M	—15" Medium	
4328T	—16" Thin	36.30B
4328M	—16" Medium	
4329T	—17" Thin	40.70B
4329M	—17" Medium	
4330T	—18" Thin	44.00B
4330M	—18" Medium	
4331T	—19" Thin	49.50B
4331M	—19" Medium	
4332T	—20" Thin	55.00B
4332M	—20" Medium	
4333T	—21" Thin	60.50B
4333M	—21" Medium	
4334T	—22" Thin	66.00B
4334M	—22" Medium	
4335T	—23" Thin	72.60B
4335M	—23" Medium	
4336T	—24" Thin	79.20B
4336M	—24" Medium	

NOTE! Cymbals or Gongs May NOT Be Returned.

Sizes NOT listed, Sizzle and Swish Cymbals, supplied on special, definite, non-returnable basis. Allow a few days for delivery. Prices include Excise Tax.

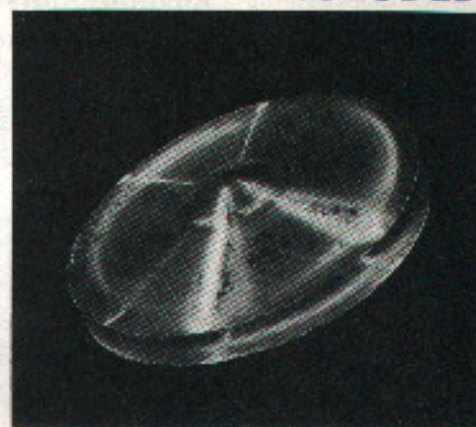

Bop Flange HI-HAT

Supplied in pairs only

Produce a new sizzling hi-hat tone. We recommend a regular Hi-Hat cymbal on top and a Flange on the bottom. Two Flange cymbals together sound too "mushy."

No.	Size	Each, Tax Included
4339T	—13" Thin	\$25.30B
4339M	—13" Medium	
4340T	—14" Thin	29.70B
4340M	—14" Medium	
4341T	—15" Thin	33.00B
4341M	—15" Medium	
4342T	—16" Thin	36.30B
4342M	—16" Medium	



• AVEDIS ZILDJIAN • "SIZZLE" CYMBALS

Regular cymbals, eighteen to twenty-two inches in diameter, in which holes are drilled and rivets installed to give a sizzling or buzzing type of cymbal sound.

No.	Size	Each, Tax Included
4330ZT	—18" Thin	\$44.00B
4330ZM	—18" Medium	
4331ZT	—19" Thin	\$49.50B
4331ZM	—19" Medium	
4332ZT	—20" Thin	\$55.00B
4332ZM	—20" Medium	
4333ZT	—21" Thin	\$60.50B
4333ZM	—21" Medium	
4334ZT	—22" Thin	\$66.00B
4334ZM	—22" Medium	

NOTICE!

Cymbals will crack through misuse or accident, and cannot be guaranteed, for many reasons. Cymbals, like drumheads, are directly struck, putting them under strain. Topnotch cymbals are of such high temper (extremely necessary for good tone) that it is impossible to guarantee their durability.

ROGERS • PASHA • CYMBALS



Acclaimed by many prominent drummers and bandsmen as the very finest Turkish type, imported cymbals on the market. They have that brilliant, penetrating and resonant tonal quality especially suitable for modern orchestra use. Cymbals CANNOT be guaranteed perfect in size or weight.

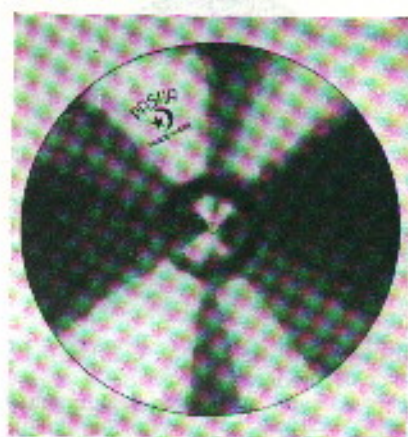

PASHA "THIN" CYMBALS

Sharp, high pitched tone, instant response, ideal for fast crash and splash effects.

No.	Each
4301—Paper Thin, 10"	\$ 6.00
4302—Paper Thin, 11"	7.00
4303—Paper Thin, 12"	8.00
4304—Paper Thin, 13"	11.00
4305—Paper Thin, 14"	13.50
4128—Thin, 15"	17.50
4260—Thin, 16"	20.00
4261—Thin, 18"	27.50
4262—Thin, 20"	36.75

PASHA "MEDIUM" CYMBALS

Good for Hi-Hat, crash effects and tip work. Big, piercing, responsive tone. Ideal for "Bounce" or "Ride".

No.	Each
4214—Medium, 12"	\$11.50
4264—Medium, 13"	14.00
4265—Medium, 14"	15.75
4129—Medium, 15"	19.00
4266—Medium, 16"	22.00
4267—Medium, 18"	31.50
4268—Medium, 20"	41.00
4269—Medium, 22"	63.50

PASHA "HEAVY" CYMBALS

Ideal for Band, Drum Corp. or Symphony. Matched heavy cymbals, selected for rich, brilliant tone and sustained vibration. Listed and priced singly, but should be ordered by "pair" and with proper straps and pads, if desired.

No.	Each
4371—Heavy only, 12"	\$11.00
4372—Heavy only, 13"	15.00
4373—Heavy only, 14"	17.50
4306—Heavy only, 15"	20.00
4307—Heavy only, 16"	25.00



FINGER CYMBALS

Made of highly polished gold lacquered brass with silk elastic finger straps. Set of four, boxed.

No. 220—Brass, gold lacquered. Set \$3.30
No. 221—Polished nickel plated. Set 3.85



RHYTHM CYMBALS

Brass, 7" size, with knobs for holders. No. 4317 ----- Per Pair \$4.85



ZILCO • CYMBALS

Made by Avedis Zildjian Co. Fine Turkish style cymbals. Paper Thin—Medium—Heavy. Prices subject to change without notice.

No.	Size	Each, Tax Included
4362	8 inch, paper thin	\$6.60B
4363	9 inch, paper thin	7.70B
4364	10 inch, paper thin	11.00B
4365	11 inch, paper thin	13.20B
4366T	12" Thin	Tax Paid \$16.50B
4366M	12" Medium	
4366H	12" Heavy	
4367T	13" Thin	19.80B
4367M	13" Medium	
4367H	13" Heavy	
4368T	14" Thin	23.10B
4368M	14" Medium	
4368H	14" Heavy	
4369T	15" Thin	26.40B
4369M	15" Medium	
4369H	15" Heavy	
4370T	16" Thin	30.80B
4370M	16" Medium	
4370H	16" Heavy	

• ALLEGRO • LIQUID CYMBAL POLISH



No. 4318—Compounded of fine ingredients, especially for cymbals. Preserves, cleans and improves cymbal. ----- Each \$1.50

• ZILDJIAN • GONGS

Tax Included
Stand Extra

Zildjian Gongs answer the demand of schools and symphony orchestras for fine quality, low pitched gong tone. In medium heavy weights. Gongs are not returnable; not guaranteed to be exact in size.

No.	Size	Tax Included Each
4394	20"	\$ 66.00B
4395	22"	77.00B
4396	24"	89.00B
4397	26"	110.00B
4398	28"	132.00B

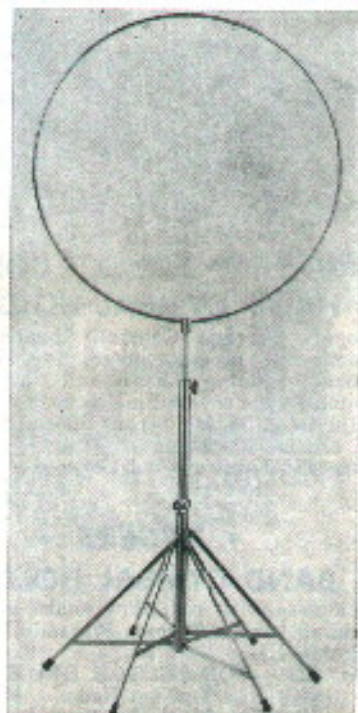

STAND FOR GONGS

Nickel-plated
No. 1592—Hexapod Stand, solid, reliable. STATE gong size. Each \$24.50

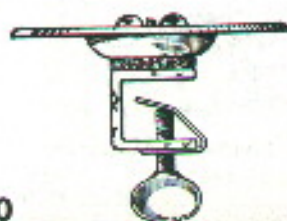

GREEKO CYMBALS

Two different sizes and pitches, complete with clamps.

No. 225
Pair \$3.30

CYMBALS—BAND CYMBAL ACCESSORIES



DEEP CUP BRASS CYMBALS

Not Recommended For Band Use

Bell brass, hand spun. For fast crash and "hot sock" effects.

No. 310A—10 Inch	Each	\$6.05
No. 311A—11 Inch	Each	6.60
No. 312A—12 Inch	Each	7.95

CYMBAL CARRYING CASE

No. F18R—Each \$9.50B



Size 18 1/2" x 18 1/2" x 6 1/2". Holds any size up to 18". For band, concert or dance. Good quality fibre.

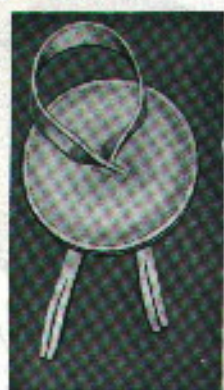

• ROGERS • LEATHER PADS

Top-grain double leather cymbal pad with heavy felt inter-lining. Permits full cymbal vibration and protects knuckles. Cellophane wrapping.

No. 4380—Cymbal Pad only Ea.	\$1.20
Per Pair	2.40

LEATHER STRAPS

Cymbal strap to match No. 4380. Individual cellophane wrapping.

No. 4381—Strap only	Each \$.60
Per Pair	1.20

PAD & STRAP SETS

No. 4379—Set, for 2 hands,	Total Price	\$3.60
----------------------------	-------------	--------

Set consists of 2 No. 4380 Pads and 2 No. 4381 Straps, for 2 cymbals.



BAND CYMBAL HOLDER

Holds cymbal securely to bass drum. No. 996

Each \$3.50



CYMBAL CARRYING BAGS

Custom-tailored of genuine Plasti-Leather. New "puff"-style design accommodates cymbals with or without hand-grips. Removable, adjustable; clip-on shoulder straps. Heavy-duty luggage handles. Long, easy-sliding zipper. Leather nameplate.

No. Size	} \$15.00	Each
4270—For 14"		
4271—For 15"		
4272—For 16"		
No. Size	} \$22.50	Each
4273—For 18"		
4274—For 19"		
4275—For 20"		
4276—For 21"		
4277—For 22"		



• ROGERS • SURE-GRIP HOLDERS

Rogers "Sure Grip" Cymbal holder. Hardwood handle, neatly shaped. Sealed and lacquered. Strong, adjustable leather strap.

No. 4387—Hardwood Holders	Per Pair \$2.25
---------------------------	-----------------



• ROGERS • PERFECT CONTROL HAND CYMBAL HOLDERS

Rogers "Perfect Control" Cymbal Holder. Facilitates proper control for all cymbal work including swish and light attack. Lamb's wool covered metal base with strong adjustable leather strap. Specially designed to eliminate fatigue.

No. 4388 Lamb's Wool Covered Holders	Pair \$4.50
--------------------------------------	-------------

• ROGERS •

BAND CYMBAL HOLDERS

Complete with rod, claw hooks and cymbal holding unit. Chrome-Plated (WITHOUT CYMBAL).

No. 4235—FOR SCOTCH DRUM, with Key Tension Rods (Specify Shell Size)	-----Ea.	\$5.50
No. 4236—FOR BASS DRUM, with Tympani Handle Rods (Specify Shell Size)	-----Ea.	5.95

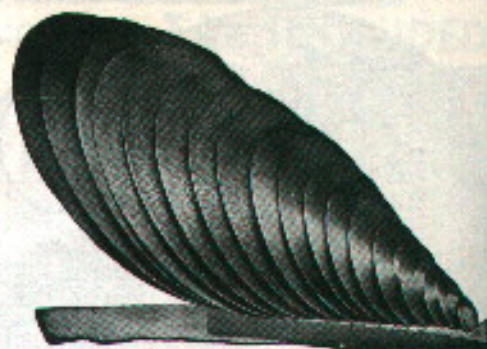

BRASS CYMBALS

Hand Spun Brass, Regular Type

<i>Not Recommended For Band Use</i>		Each
No. 305—5 Inch	-----	\$1.85
No. 307—7 Inch	-----	2.20
No. 308—8 Inch	-----	3.30
No. 309—9 Inch	-----	4.40
No. 310—10 Inch	-----	5.50
No. 311—11 Inch	-----	6.30
No. 312—12 Inch	-----	7.40
No. 313—13 Inch	-----	8.25
No. 314—14 Inch	-----	9.90
No. 315—15 Inch	-----	11.00



• ROGERS • REGULATION LAMB'S WOOL PADS

Professional quality pad, heavy lamb's wool covered top-grain leather, with felt insert. Affords the maximum in cymbal vibration and knuckle protection. Individual cellophane wrapping.

No. 4382—Cymbal Pad only Ea.	\$3.00
Per Pair	6.00

LAMB'S WOOL STRAPS

Cymbal strap, lamb's wool on rawhide. Individual cellophane wrapping.

No. 4383—Strap only	Each \$1.75
Per Pair	3.50

• ROGERS • LAMB'S WOOL PAD & STRAP SETS

No. 4384—Set for 2 hands,	Total Price	\$9.50
Set includes 2 No. 4382 Cymbal Pads and 2 No. 4383 Straps, for 2 Cymbals.		

A new idea in band cymbal holders

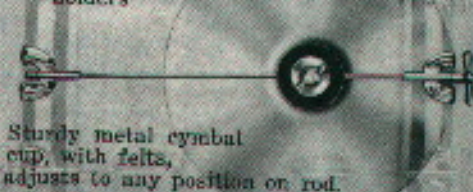

Sturdy metal cymbal cup, with felts, adjusts to any position on rod.

• ROGERS • CYMBAL HOLDERS

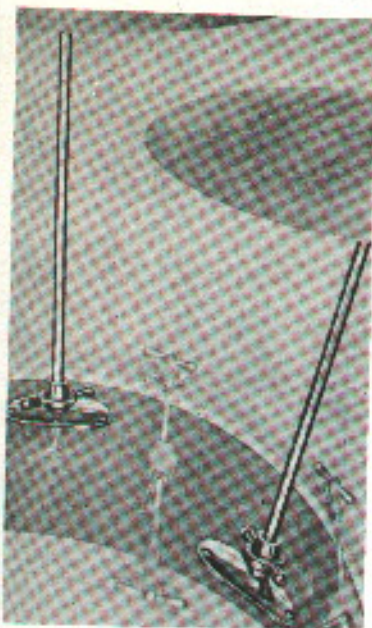

• SWIV-O-MATIC • DISAPPEARING INTERNAL CYMBAL HOLDERS

Chrome • Hexagon • Boxed

No. 330R — Straight Mount, complete with collet, plate assembly and felts Each **\$7.50**

No. 331R — Angle Mount, complete with collet, plate assembly and felts Each **\$8.00**

Special hexagon steel rod, adjustable to 18"; disappears into shell. Stop-bar prevents rod from dropping inside and also acts as pull-out handle. Plate is equipped with collet assembly which provides positive grip. DeLuxe chrome finish. Individually boxed.

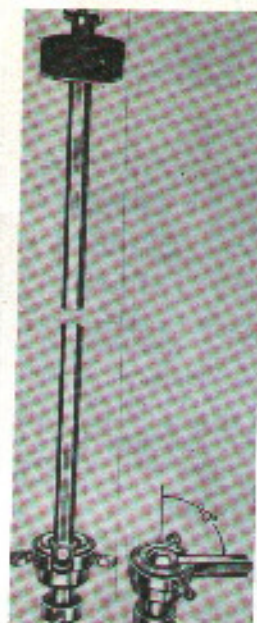

• SWIV-O-MATIC • EXTENSION CYMBAL ARM

No. 325R — Cymbal Extension Arm, acts like a filter. Fits Rogers and all other cymbal holders, Boxed Ea. **\$5.50**

Special hexagon steel rod with all-directional SWIV-O-MATIC unit. Adds height and angle to cymbal holder. Permits tilt within 360°. Cut-out provides 90° angle tilt. Fits all makes. Adjusted with any standard drum key. Base is hex-broached to prevent turning on hex rods. Will also fit standard round rods. DeLuxe Chrome finish.

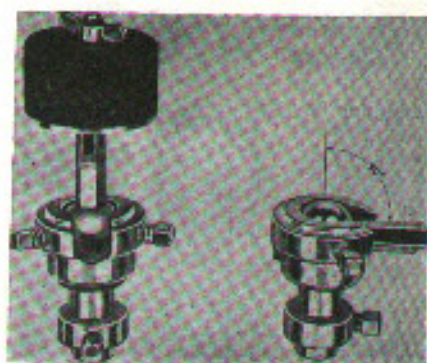
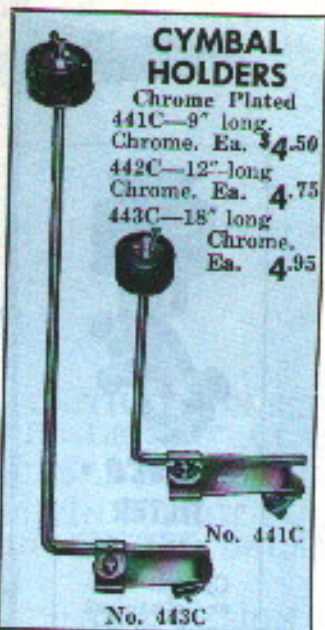

• SWIV-O-MATIC • CYMBAL TILTER

Chrome • Boxed • Fits All Makes

No. 320R — All-directional Tilter, for Rogers and all other cymbal rods. Fits all makes Each **\$4.50**

Made with all-directional SWIV-O-MATIC unit, permitting cymbal to tilt to any playable position within 360°. Cut-out provides 90° angle tilt. Locks with any standard drum key. Base is hex-broached to prevent turning on hex rods. Will also fit standard round rods. DeLuxe chrome finish. Individually boxed.

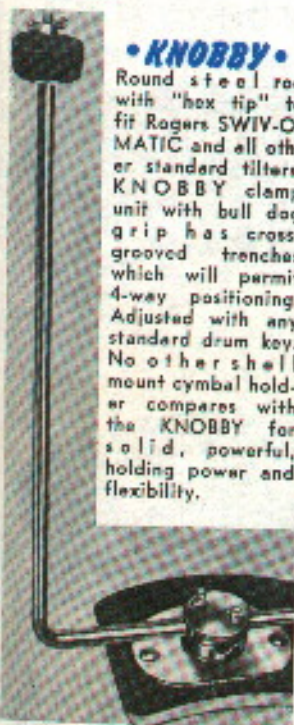

• KNOBBY •

Round steel rod with "hex tip" to fit Rogers SWIV-O-MATIC and all other standard tilters. KNOBBY clamp unit with bulldog grip has cross-grooved trenches which will permit 4-way positioning. Adjusted with any standard drum key. No other shell mount cymbal holder compares with the KNOBBY for solid, powerful, holding power and flexibility.

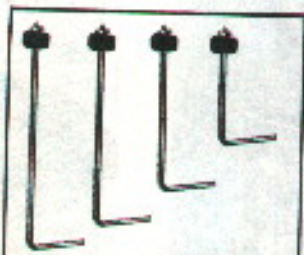

CYMBAL ARMS

With "Hex Tip" and Felt Assembly. DeLuxe Chrome

No. 256R—9 inch Ea. **\$1.95**

No. 257R—12 inch Ea. **2.25**

No. 258R—15 inch Ea. **2.50**

No. 259R—18 inch Ea. **2.75**

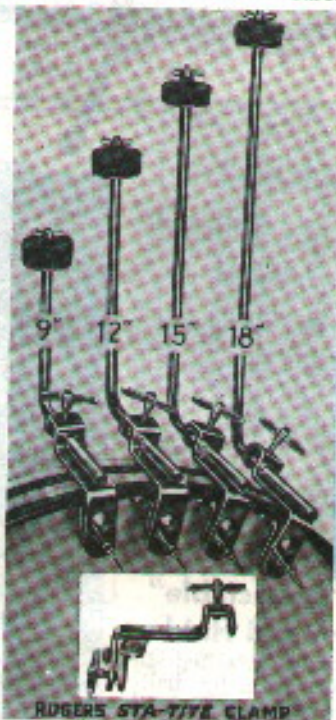

• STA-TITE • HOOP MOUNT CYMBAL HOLDERS

No. 4124—9" Size **\$4.95**

No. 4125—12" Size **5.25**

No. 4126—15" Size **5.50**

No. 4127—18" Size **5.75**

No. 255R—Telescopic, from 12" to 23", with felt assembly. Standard drum key adjustment (not illustrated) **\$7.95**

The STA-TITE unit supplied with these holders is the last word in hoop clamps. Serrations on clamp jaw assure positive, grip on hoop. Round steel arms are fitted with a special "hex tip", designed to fit the hex broach of the Rogers tilter to prevent turning. Will also fit any other standard tilter. DeLuxe chrome finish.

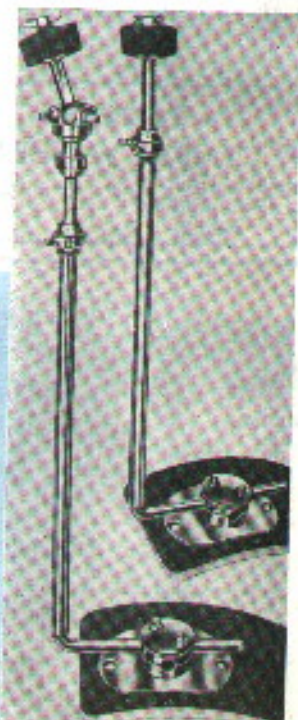

• KNOBBY • TELESCOPIC SHELL MOUNT CYMBAL HOLDERS

DeLuxe • Chromium Plated

No. 250R—KNOBBY "Telescopic" Cymbal Holder Each **\$10.00**

No. 251R—Same, but with regulation cymbal tilter (not illustrated) Each **\$11.50**

No. 252R—Same, but with Rogers SWIV-O-MATIC Tilter **\$13.50**

Cleverest and most practical of all shell mount cymbal holders. Telescopes from 12" to 23". Equipped with "hex tip" designed to fit hex broach of the Rogers SWIV-O-MATIC tilter to prevent turning. Will also fit other tilters. Has positive-lock collar. The incomparable KNOBBY cross-grooved trenches permit 4-way positioning. Grips with bulldog tenacity. Adjusted with any standard drum key. Provides solid, positive holding power.

CYMBAL HOLDERS - STANDS & TILTERS

Cymbals are NOT included in prices quoted on Stands

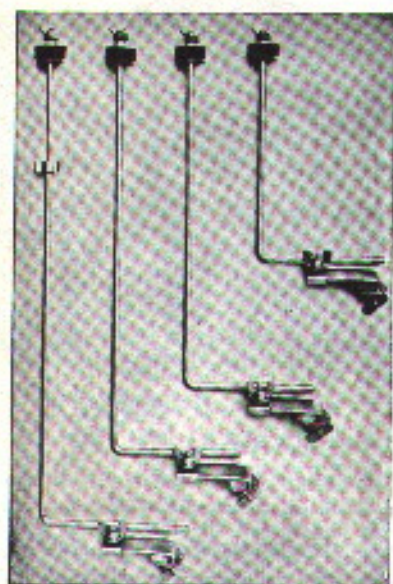

WING-NUT CYMBAL HOLDERS — NICKEL-PLATED

No.	Size	Each
No. 1451R	—9"	\$2.75
No. 1452R	—18"	2.85
No. 1453R	—21"	2.95
No. 1454R	—Adjustable	4.00

• ROGERS •

CYMBAL WASHERS

No. 4385	—Felt	Each	\$.10
No. 4386	—Rubber	Each	.12

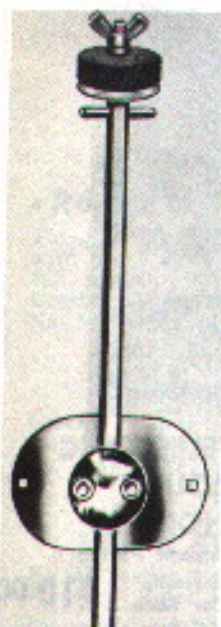

• ROGERS • Knobby Shell-Mount Cymbal Holder

No. 249R—18" hex cymbal rod with the incomparable KNOBBY unit. For mounting on floor tom-tom and cocktail drum.
Each \$8.25

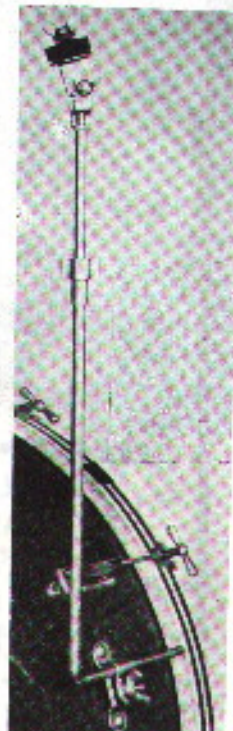

"Bolt-On" Adjustable Cymbal Holder

Bolts on bass drum. Adjusts to any height.
No. 1719T—With tilter, nickel \$5.25

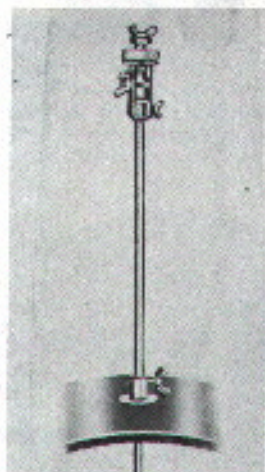

"Retractable" Cymbal Holder

Easily attached to bass drum by drilling one hole in shell. Adjusts to any height. Comes complete with tilter.
No. 1704A—With Tilter, \$5.00
Each

• ROGERS • ROCKING CUP

Professional quality rocking cup for standard model Cymbal Holder.
No. 4393 — Each75



• CAMCO • TILTER Nickel

Cymbal Tilter Ratchet type adjustment.
No. 4376
Each \$1.80

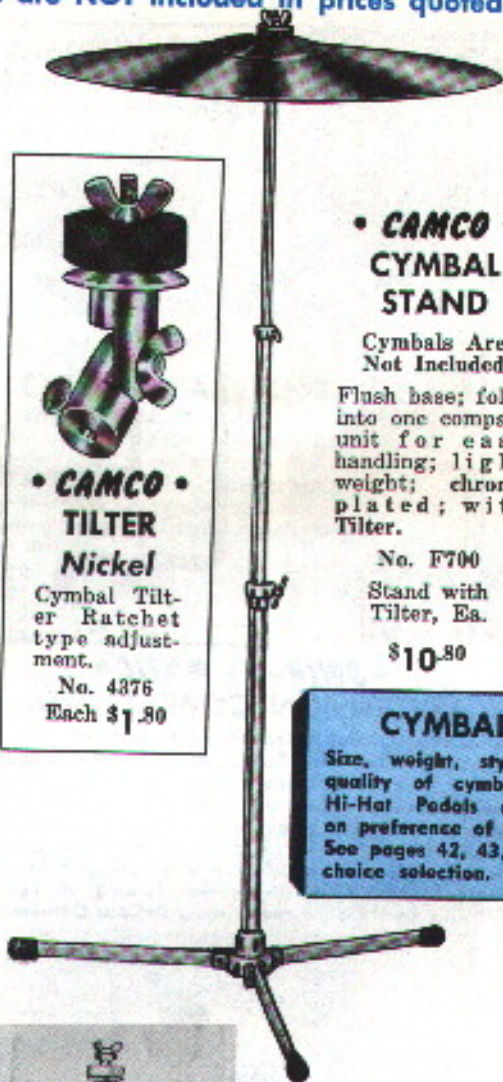

• CAMCO • CYMBAL STAND

Cymbals Are Not Included
Flush base; folds into one compact unit for easy handling; light weight; chrome plated; with Tilter.

No. F700
Stand with Tilter, Ea.

\$10.80

CYMBALS

Size, weight, style and quality of cymbals for Hi-Hat Pedals depends on preference of players. See pages 42, 43, 44 for choice selection.



FLAT BASE FLOOR CYMBAL STAND WITH TILTER

A heavy duty type cymbal stand that holds the largest cymbal safely. Equipped with cymbal tilter.
No. 1725—Nickel\$8.95
No. 1725C—Chrome 9.95

• ROGERS • RUBBER TIPS

No. 4418 — For spurs, stands, etc.
Dozen ---- \$1.80

THROW-OFF CYMBAL SIZZLER



SIZZLERS ON
Just flip them down with your stick.



SIZZLERS OFF
Just flip them up with your stick.



CYMBAL TILTER

The original reliable tilter. Will not turn or tip while being played.
No. 1666—
Nickel\$1.75
No. 1666C—
Chrome ---- 2.25

Now the drummer can be sure of the same quality of sounds for sizzle work as produced by his favorite Cymbal. THROW-OFF CYMBAL SIZZLER can be quickly adjusted to all size Cymbals up to 22" in a few seconds. Square sliding arms enable drummer to place sizzlers at the desired distance from the edges.
No. 730—Throw-Off Cymbal \$3.60
Sizzlers, Each

NEW • ROGERS • STANDS AND HI-HATS

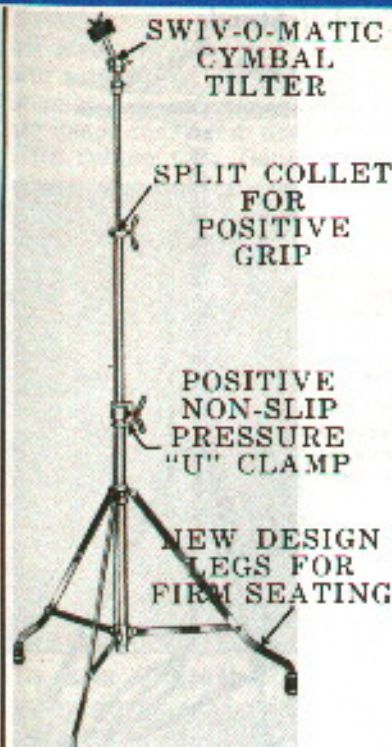

SWIV-O-MATIC
CYMBAL
TILTER

SPLIT COLLET
FOR
POSITIVE
GRIP

POSITIVE
NON-SLIP
PRESSURE
"U" CLAMP

NEW DESIGN
LEGS FOR
FIRM SEATING

No. 4403
• ROGERS •
"PROFESSIONAL"
CYMBAL FLOOR STAND

Chrome Plated

\$14.50

No. 4405—Same as above, without
tilter, but with cymbal
felt and washer **\$10.50**

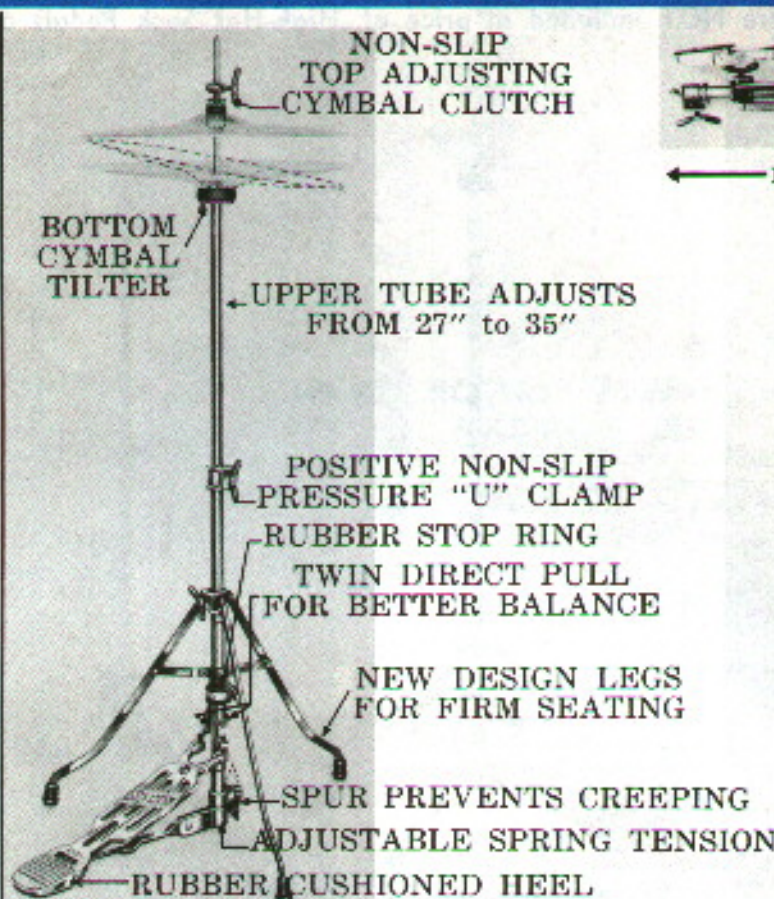

NON-SLIP
TOP ADJUSTING
CYMBAL CLUTCH

BOTTOM
CYMBAL
TILTER

UPPER TUBE ADJUSTS
FROM 27" to 35"

POSITIVE NON-SLIP
PRESSURE "U" CLAMP

RUBBER STOP RING

TWIN DIRECT PULL
FOR BETTER BALANCE

NEW DESIGN LEGS
FOR FIRM SEATING

SPUR PREVENTS CREEPING

ADJUSTABLE SPRING TENSION

RUBBER CUSHIONED HEEL

• ROGERS • "SWIV-O-MATIC" No. 4401
HI-HAT PEDAL

With 2-piece footboard. Chrome Plated.
(WITHOUT CYMBALS)

\$29.50

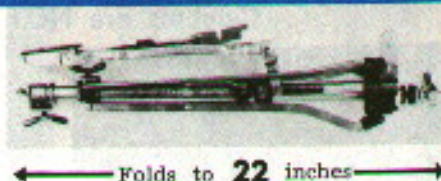

Folds to **22 inches**

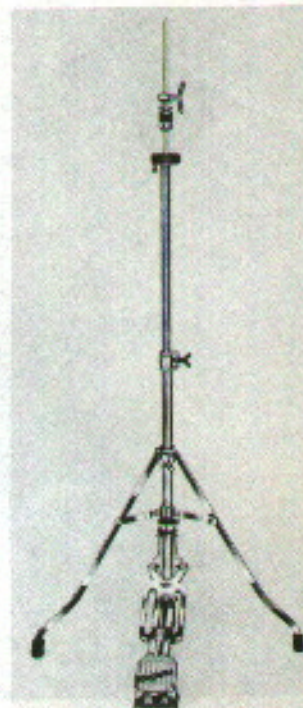

Same as Number
4401, but with
1-piece footboard.

No. 4402 \$29.50

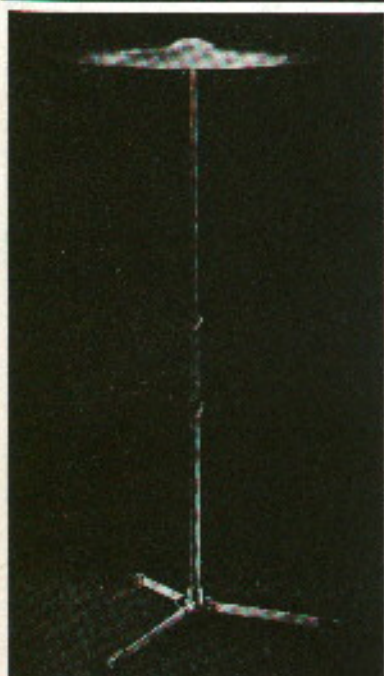

• UTILITY •
CYMBAL STAND

Cymbal NOT Included

No. 4400R—Chromium-plated. Ad-
justable, can be set-up
or folded instantly.
Flush base with rubber
floor grips to prevent
creeping. Supplied with
rubber cymbal tip. Cym-
bals not included.
Each **\$12.00**



HI-HAT CLUTCH

No. 1250—A worthwhile
replacement accessory for
old or worn-out clutch.

Each **\$1.00**

No. 4404
• ROGERS •
HI-HAT
CLUTCH

Chrome Plated

\$3.00

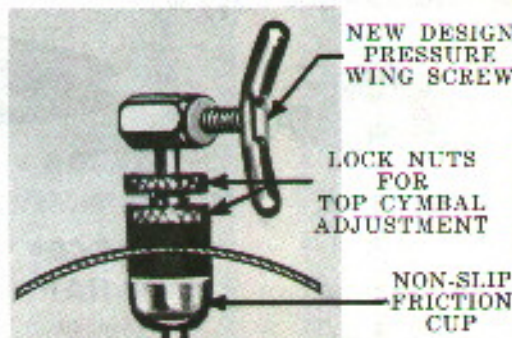

NEW DESIGN
PRESSURE
WING SCREW

LOCK NUTS
FOR
TOP CYMBAL
ADJUSTMENT

NON-SLIP
FRICTION
CUP

HI-HAT SPURS

Attaches to back leg of Highhat.
Stops Highhat from creeping.



No. 1628

Fits most Regular
Model Hi-Hat ped-
als. Nickel-plated.

Each **\$1.25**



No. 1628D

Fits most Flat Base
Model Hi-Hat ped-
als. Nickel-plated.

Each **\$1.25**

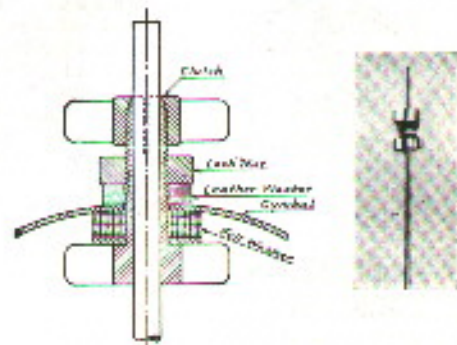

"ZIP" CLUTCH

No. 1282—Nickel Each **\$1.50**

The Zip clutch enables the drummer to at-
tach or remove the cymbal from his high-
hat or cymbal holder in one second without
removing thumbscrews or washers. Will fit
any plain or threaded high hat or 1/4" cym-
bal holder rod.

HIGH - HAT (SOCK - CYMBAL) PEDALS

Cymbals are NOT included in price of High-Hat Sock Pedals or Cymbal Stands

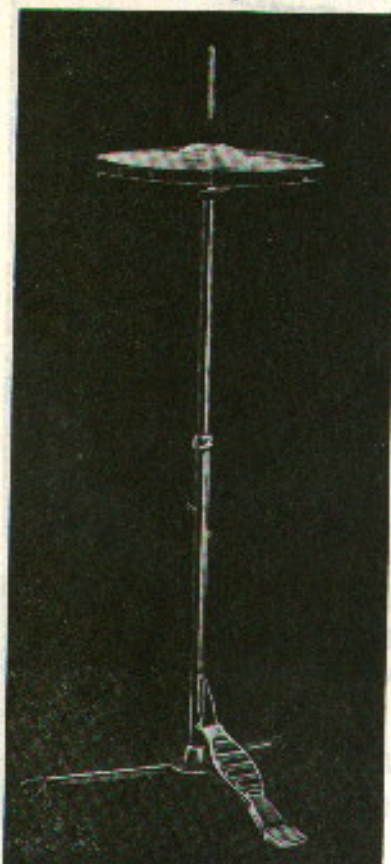

"UTILITY" HI-HAT

Cymbals NOT Included
No. 4378R — Chromium-plated. Flush base with rubber floor grips to prevent creeping. Fast, silent, solid foot-board. Quickly adjustable. Each, Chromium-Plated ...\$17.50

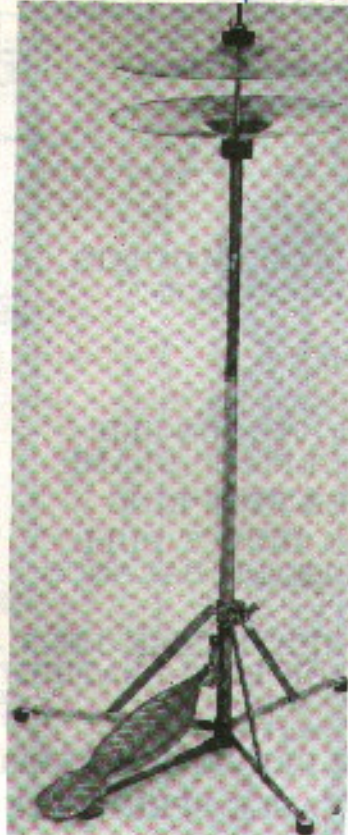

FLAT BASE HI-HAT

Cymbals NOT Included
No. 1727—Folds in one piece. Cross bar re-inforced flush base. Advanced design. Each, Nickel plated ...\$15.00

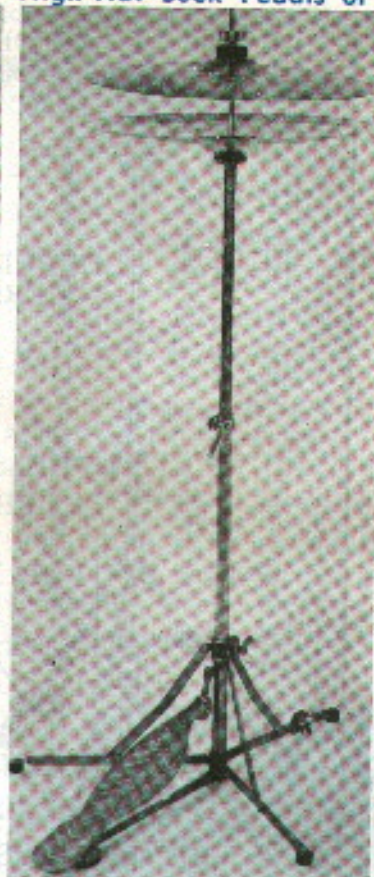

DE LUXE HI-HAT "ADJUSTABLE"

Cymbals NOT Included
The first highhat with adjustable spring
Spring can be adjusted for different size cymbals. Also adjustable for height. Folds in one piece.
No. 1729C—Chrome-Plated
Each\$21.50



• ECONOMY • HIGH-HAT

Folds in one piece. Lifetime link, direct pull. Height 32" to bottom cymbal. Folds to 23 1/4" in one piece. Nickel-plated.
No. 1504—(Without Cymbals)
Each\$12.50

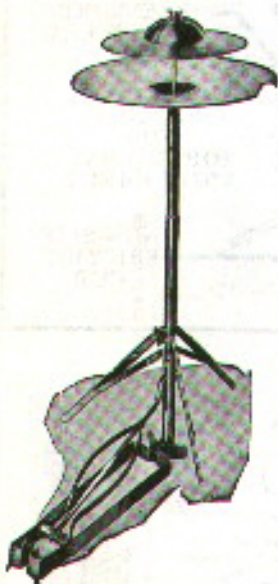

• PERFECTION • SOCK PEDAL

Cymbals NOT Included
Holds the cymbals 36 inches from the floor. Excellent for working up crescendos and for on or after beats. Folds compactly.
No. 502—Nickel-plated, without cymbals. Each... \$15.00
No. 503C — Chrome finish, without cymbals ...\$17.50
Each



• CAMCO • HI-HAT

Cymbals Not Included
Flush steel legs, rubber tipped, will not creep. All parts fold compactly to 21", nothing to lose. Adjustable from 28" to 38". Silent, smooth, chrome-plated.
No. F1200—Each \$20.00

HOLLYWOOD HI-HAT PEDAL

No. 502HC - Chrome \$19.50

The original high-hat, so popular with top notch professional drums with the following added features:
Adjustable spring to adjust tension for different size cymbals.
Zip clutch for instant cymbal removal.
Zip one piece folding, no parts to lose.
Height adjustment on top tube.
Large easy tightening height adjustment lever.
Retractable spur that can be retracted and used with rubber tip.



• RHYTHM KING • DIRECT PULL Adjustable HI-HAT

Chrome Plated
No. 1680C
Without Cymbals Ea. \$20.00
A solid stand with smooth, fast, noiseless direct center pull action. Fully adjustable, for sitting or standing position, from 29" to 37". Folds in one piece to 21 1/2". Solid aluminum alloy foot board, Zip Clutch.

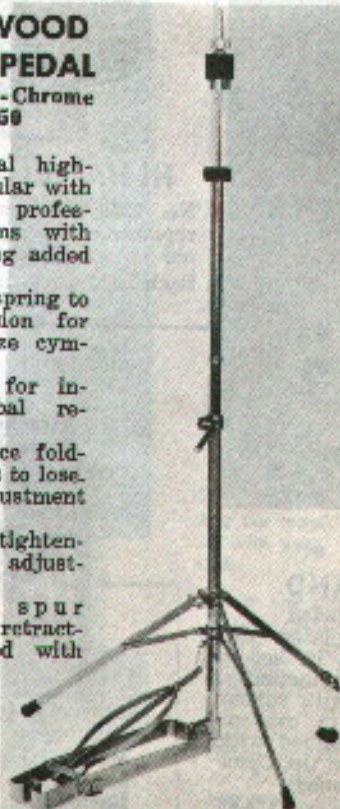

• ROGERS • BASS DRUM SPURS

• ROGERS • Internal (Disappearing) SPURS

All steel construction. Hexagon rods fit into a broached collet plate that prevents turning and assures positive grip. Stop-bar keeps rods from dropping inside drum. With rubber tips. Deluxe chrome plated.



No. 335R -----\$9.75
for 20" Bass Drum
Straight plate for wider
spread but less
downward angle.



No. 335R — \$9.75

No. 340R -----\$10.95
for 22" Bass Drum
Angular plate provides
downward position for
solid support.



No. 340R — \$10.95

No. 338R -----\$10.95
for 20" Bass Drum
Plate with shorter
angle for proper posi-
tioning on 20" bass.

No. 338R — \$10.95

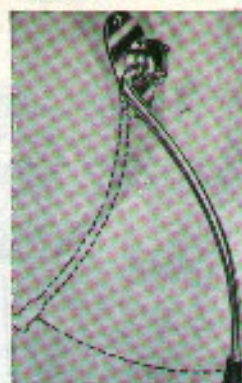

ROGERS • KNOBBY • FOLDING SPURS

Shell Mount

No. 240R—Deluxe Chrome
Plated. ---Pair\$11.50

Specially designed for
compactness and utility.
Knobby shell mount unit
grips spur with bulldog
tenacity. Fits all size bass
drums. Folds against shell
when not in use. Adjust-
ed with standard drum
key.



ROGERS • KNOBBY • Hoop Mount

No. 241R — HOOP MOUNT
Folding Spurs, with "STA-
TITE" Knobby unit, Deluxe
Chrome plated. Adjusted
with standard drum
key ----- \$12.50

No. 340R — \$10.95



RETRACTABLE SPURS

Attach to bass drum in a few minutes
by drilling two holes in shell. Spur
pointed on one end and rubber tipped
on other can be used either way in-
stantly.

No. 1705—Nickel ----per pair \$4.50



REVERSIBLE ADJUSTABLE SPURS

Adjustable for angle and height. Instantly
reversible positive hoop clamp.

No. 1726—Nickel-Plated. -----Pair \$4.50

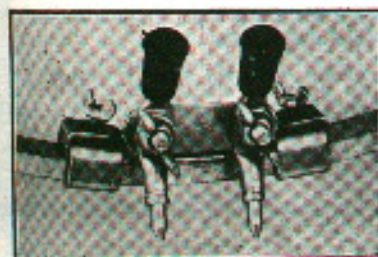

BASS DRUM ANCHOR

The standard anchor with most top
flight professional drummers. Posi-
tively stops bass drum from creep-
ing. Reversible rubber or pointed
tips.

No. 1601—Nickel ----Each \$4.50
No. 1601C—Chrome -- Each \$5.25

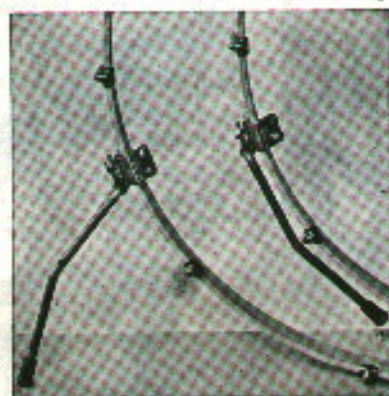

FLASH FOLDING SPURS

Attach to drum shell with wrench. Fold like
a jackknife. Open and close in a flash.

No. 1469 —Rubber Tips . Per Pair \$4.50
No. 1469½—Pointed Tips . Per Pair 4.50



Standard
Spurs
Nickel
No. 1542
Pair
\$1.35



• ROGERS • REVERSIBLE SPURS

For use with metal or
rubber tip. Adjustable
to any angle. Boxed.

No. 4410
Chrome-plated
Pair
\$5.50

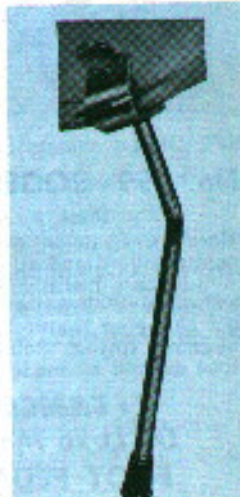

No. 4412 • ROGERS • GIANT SPURS

Heavy construction.
Good sturdy spurs.
Chrome plated.

4412—Rubber Tip,
for bass drums 22"
or larger. Boxed.
Chrome.

Pair -----\$3.75

4411—Metal Tip,
for bass drums 22"
or larger. Boxed.
Chrome.

Pair -----\$3.75

4413—Rubber Tip,
for 20" bass drum,
or smaller. Special
design. Chrome.

Pair -----\$3.75



SECURITY SPURS

No. 1279—Rubber Tips.
Per Pair, Nickel \$2.35

No. 1279½—Pointed
Tips.
Per Pair, Nickel \$2.35

• ROGERS • RUBBER TIPS

No. 4418 — For
spurs, stands, etc.
Dozen ---- \$1.80

• ROCKSTOP • SPUR STOP

No. 5882—Spur Anchor, Each \$1.75

Designed to add stability to—drum
spurs. Helps drum stay put on slip-
pery floors. Ideal for Bass drum
spurs, drum anchors, high hat spurs,
cello end pins. Light, compact, easy to
use, protects rugs, floors.



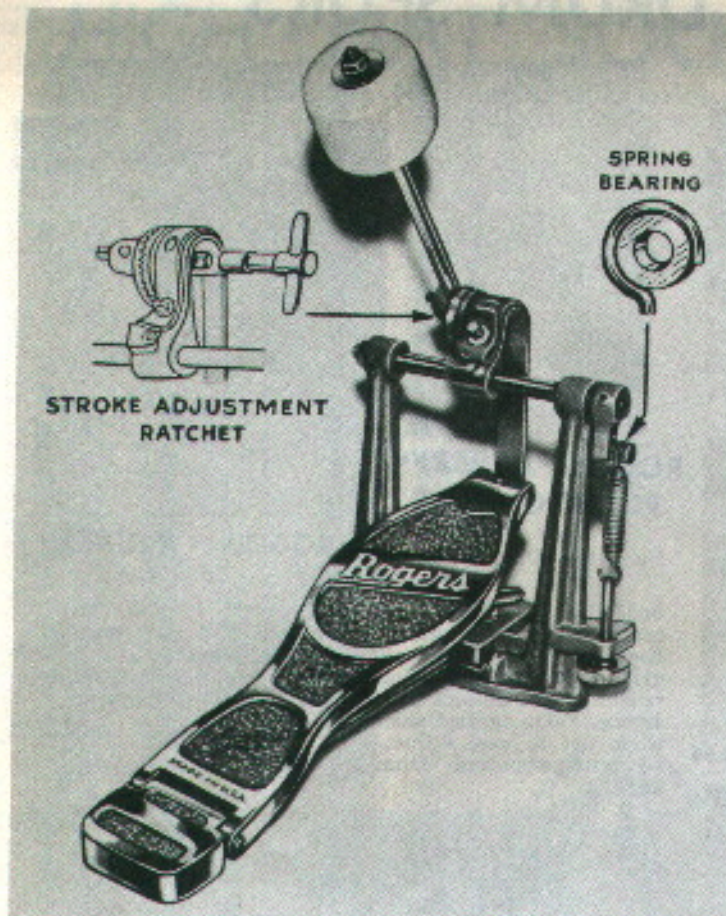

Pat. Pend.

No. 399—ROGERS "JET" SPEED PEDAL \$19.50

With Exclusive Stroke Action Adjustment

Here's a whale of a new pedal at a moderate price. The double post standard and all other cast parts are of a new aluminum alloy — toughest metal known to the science of metallurgy. The new, exclusive ratchet-type Cam permits beater stroke adjustment without changing beater height or foot action. Fitted with jumbo, self-aligning spring. Solid felt beater ball, designed to produce the tone desired by modern drummers.

**• CAMCO •
De Luxe Model
FOOT PEDALS
Solid Felt Balls**

Deluxe model. Highly polished aluminum, no painted parts. Folds without taking anything apart. Features fast, quiet operation with complete tone control; tension control; power action; vertical stroke adjustment; footboard adjustment.

No. F4462 Each \$22.50



**• CAMCO •
Standard Model
FOOT PEDALS**

Standard model, lightweight, 80% aluminum. Fast, with tension control, power action and ball bearings at each end of shaft. Has cork beater ball. Folds fast.

No. F4461
Each \$16.95



• ROGERS • PEDAL SPRINGS

No. 394—Jumbo self-aligning pedal spring, with S-hooks and bushing, for Jet, Rocket and Swiv-O-Matic Pedals. Each **\$1.20**

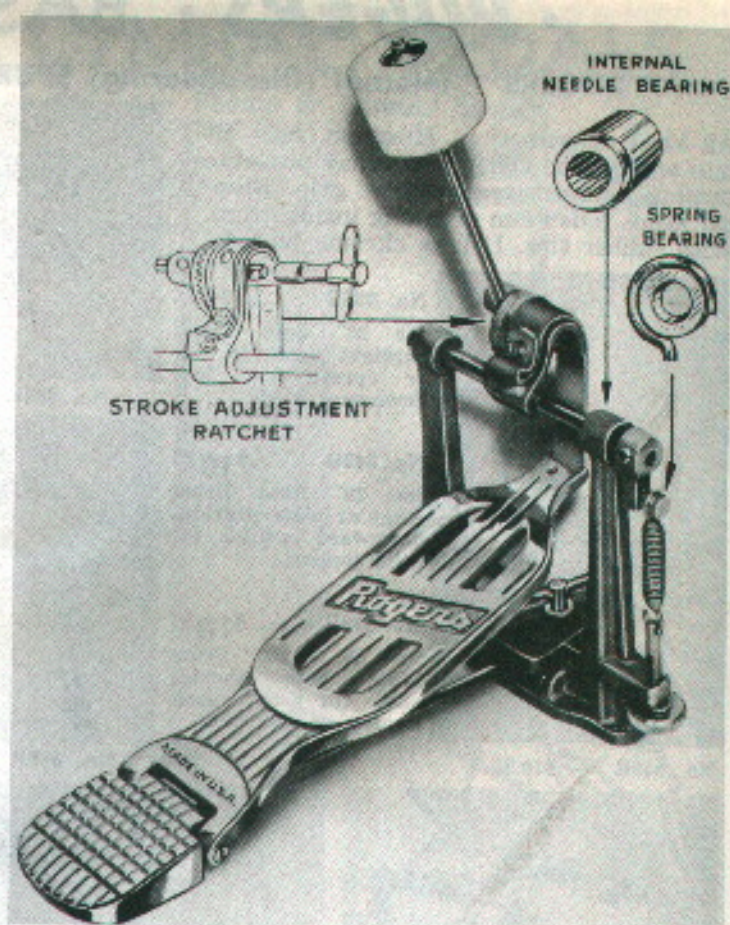

Pat. Pend.

No. 398—ROGERS "ROCKET" PEDAL \$25.00

The Rocket pedal is another product of advanced Rogers originality and skillful engineering. It embodies new exclusive (pat. pend.) features which provide lightning-fast action with a minimum of foot fatigue. Built of aluminum alloy, one of the strongest new metals the science of metallurgy has produced. Ideal for heavy duty use, so essential for modern drumming.

- New exclusive ratchet type Cam adjusts with standard drum key.
- Adjusts length of beater stroke without changing beater height. Saves foot motion, eliminates foot fatigue.
- New, needle type bearing provides smooth, speedy action.
- Two-piece footboard with hinged heel. DeLuxe, polished finish.
- Durable hoop clamp, designed also to serve as a hinge for footboard rod. Permits proper seating of pedal on any floor.
- Self-aligning, jumbo spring operates on bushing. Has large knurled knob for easy tensioning.
- High quality solid felt drum beater.

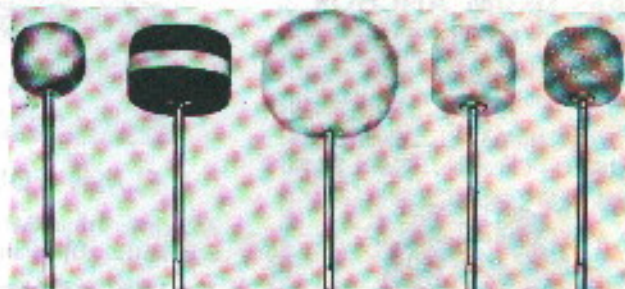

Nos. 4422 4428 4431 4420 4597
4443

• ROGERS • PEDAL BEATERS

Chrome Rods

- | | | |
|--|--------|---------------|
| No. 4422—Wood, for "bop" work, Lacquered | } Each | \$2.50 |
| No. 4443—Wood, Large, Lacquered | | |
| No. 4428—Felt, 2 tone | | |
| No. 4431—Lamb's Wool | | |
| No. 4420—Solid White Felt | | |
| No. 4597—Cork, light, fast | Each | 2.00 |

BEATER BALL COVERS

- | | | |
|--|------|--------|
| No. 4432—Cover for pedal ball, lamb's wool | Each | \$1.00 |
|--|------|--------|

•ROGERS• FOOT PEDALS

Revolutionary new design!
Cuts foot fatigue! Adjusts
to your natural position!
Gives smoothest action ever!

Note these special features:

- Built-in spurs prevent creeping of drums or pedal
- beater rod clamp is engineered for positive-permanent grip
- pedal folds up with single step into small compartment of trap case—assembles in seconds
- new needle-type bearings give maximum speed, smoothness
- so simple, it's practically trouble-free for life.

You'll play with half the effort!

For the first time you can play NATURALLY... for the first time you have a pedal designed to adjust to your own physical requirements and your own style of playing—and all you need for adjustments is a standard drum key!

Swiv-O-Matic

**GIVES YOU SMOOTHER,
FASTER RIDE,
cuts foot-work in half!**

No. 395R—Swiv-O-Matic Pedal,
with Solid Footboard

No. 396R—Swiv-O-Matic Pedal,
with Hinged Heel

\$39⁵⁰
EACH

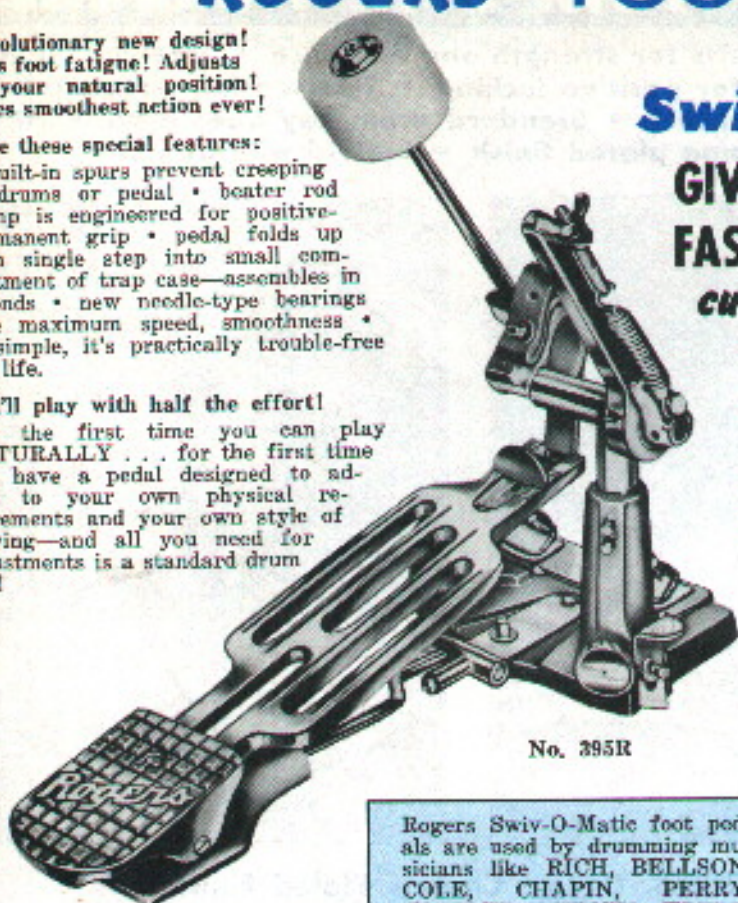

No. 395R

Rogers Swiv-O-Matic foot pedals are used by drumming musicians like RICH, BELLSON, COLE, CHAPIN, PERRY, COTTLER, BURNES, KRELL, and many others.



PAT. PENDING

No. 396R

"This pedal does for drumming what power steering does for driving." That's how one top drummer put it! This is a dream pedal. It adjusts exactly, completely to you.

Note these Swiv-o-Matic adjustments. You adjust spring tension from top — easily, instantly. You swivel footboard so you play naturally, comfortably, no matter what the stage set-up. Special hinge keeps pedal seated flat on any floor.

Attachment to bass drum is unbelievably simple, won't slip or chew hoop. Single step take-down, and pedal folds into small compartment of trap case.

You can adjust length of stroke without changing beater height. You can raise or lower beater action without changing length of stroke.

ROGERS "UP BEAT" OR "COCKTAIL" FOOT PEDAL

Designed for use with any type tom-tom leg. Eliminates special brackets, plates or bars. Attaches quickly and easily. Footboard design permits positioning to any comfortable angle, for playing in either sitting or standing position. A smooth, fast action pedal—complete, with directions.

ADJUSTS FOR

- HEIGHT
- STROKE ACTION
- FOOTBOARD ANGLE
- BEATING POSITION
- STRAP LENGTH
- SPRING TENSION



No. 205R **\$22.50**

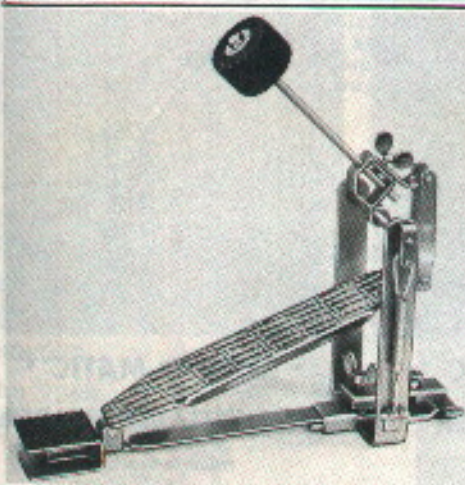

THE "CHAMP" PEDAL

A sturdy, 2-post pedal with strong steel frame, hinged footboard and steel heel, covered with non-slip rubber pad. Dependable, fast action with tension spring outside the frame. Solid felt beater ball. Exceptional value.

No. 4441—The "CHAMP" Pedal **\$9.75**

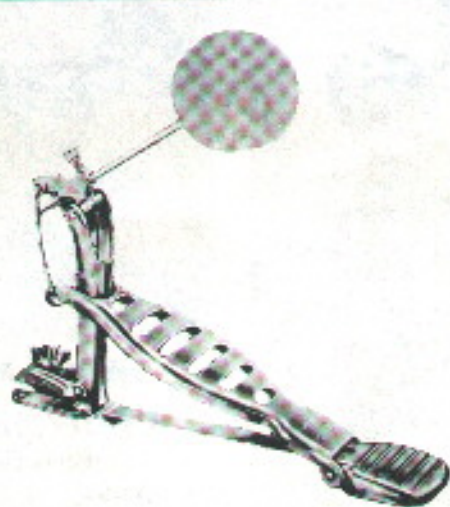

"UTILITY" FOOT PEDALS

No. 4438R—Ideal for juniors. Sturdy construction, modern design. Solid footboard, comfortable heel-plate, lamb's wool beater. Nickel-plated Each **\$10.95**

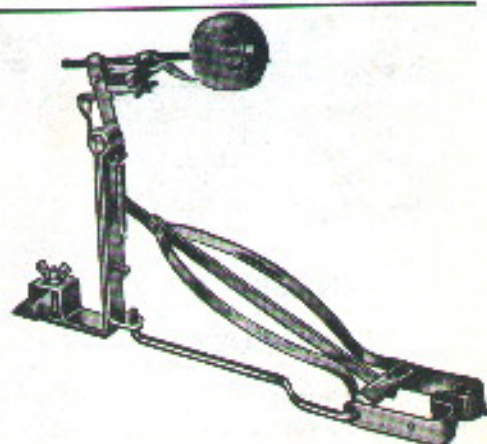

"ECONOMY" FOOT PEDAL

No. 779—A moderately priced high-speed pedal of all steel construction. Speed and light weight are combined with dependability and ease of action. Equipped with solid felt beater and adjustable cymbal striker. The ideal pedal for the amateur. **\$7.75**

SWIV-O-MATIC TOM-TOM HOLDERS

- All directional • Ball and socket with hex shafts for strength and elegance • Interchangeable
- Fast set-up and knock-down • Special collet for positive locking • Two tension screws can be switched into any of 4 holes provided for swivel lock • Standard drum key does it all • Fit all makes of drums • Highly polished deluxe chrome plated finish • Individually boxed.

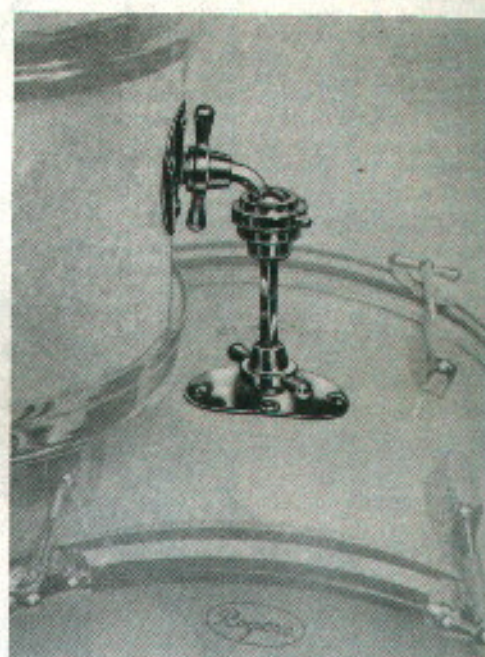
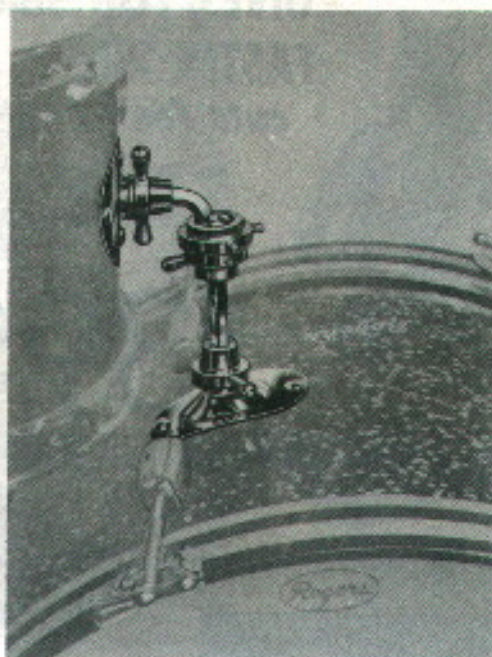
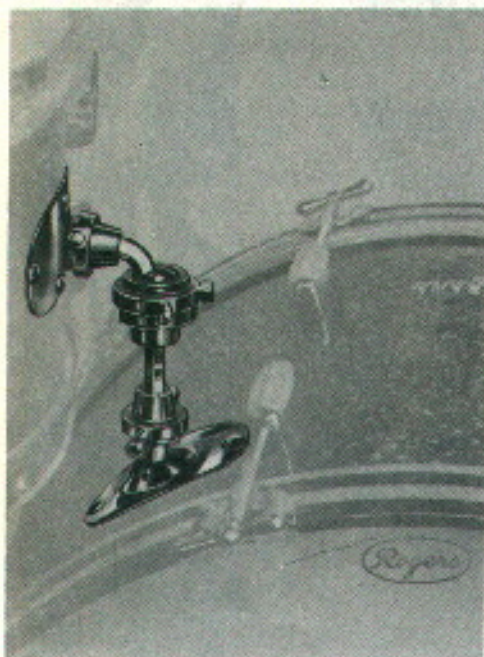

SWIV-O-MATIC "Shell-Mount" MODELS, Deluxe Chrome Plated Finish

No. 360R—For mounting of tom tom to left side of bass drum. **Each \$19.75**

No. 361R—For mounting of tom tom slightly off-center of bass drum **Each \$19.75**

No. 362R—For mounting of tom tom in center of bass drum **Each \$19.75**

SWIV-O-MATIC COLLET PLATES, Chrome plated, complete with bolts, nuts and washers for mounting.



No. 311R
Angle Mount
\$6.00
suitable for
left or
right side.



No. 312R
Short Angle
Mount
\$6.00
suitable for
left or right.



No. 310R
Straight
Mount
\$5.50
For Center
Mounting

Screws To Fit "Swiv-O-Matic" and "Knobby" equipment



No. 391-R
Swiv-O-
Matic
Set Screw
Ea. 15¢



No. 261-R
Knobby
Clamp
Set Screw
Ea. 25¢

• KNOBBY • HEAVY DUTY

Hoop-to-Bracket

No. 264R — Designed for service and durability. The "Knobby" clamp assures positive positioning of the tom-tom and grips it with bulldog tenacity. The STATITE clamp with serrated jaw provides solid holding power on the hoop. Chrome-plated finish.

\$975



No. 264R

\$975



• SWIV-O-MATIC • UTILITY HOLDER

Shell to Bracket

No. 350R—Designed to fit any standard tom-tom bracket plate. Has full adjustability features. DeLuxe Chrome.

Each \$1750



• SWIV-O-MATIC • DEMOUNTABLE HOLDER

Hoop-to-Bracket

No. 345R — Clamps onto bass drum hoop with STA-TITE unit an integral part of this holder. Has regulation bracket for tom-tom. Used for right or left mount. DeLuxe Chrome.

Each \$1500

• ROGERS • TOM TOM HOLDERS and LEGS

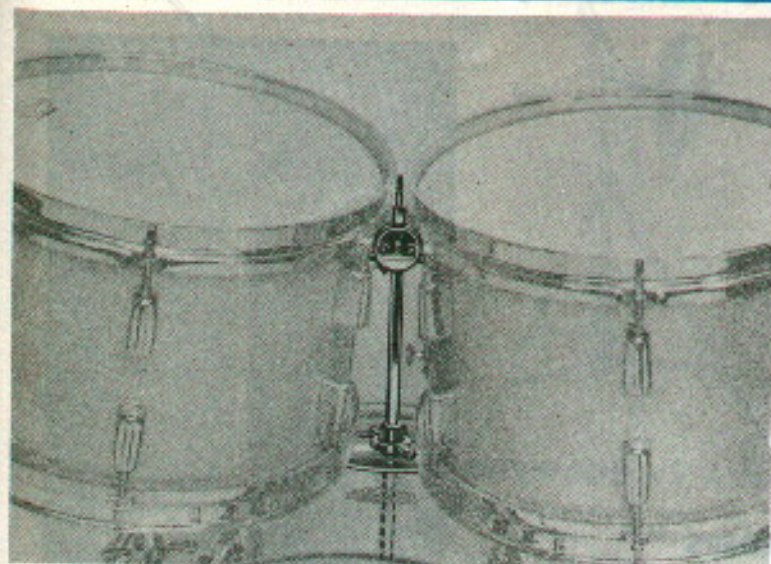

2 Tom Toms Close Together

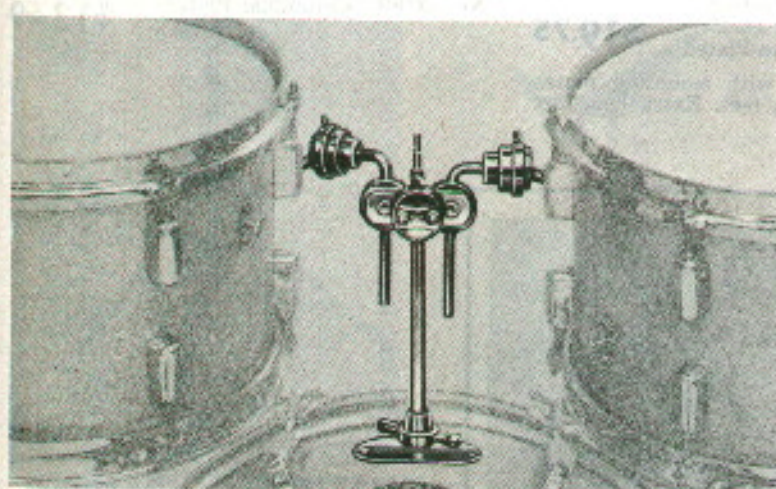

2 Tom Toms Spread Apart

ROGERS • SWIV-O-MATIC® • TWIN TOM-TOM HOLDER

No. 365R—Chrome-Plated Each **\$39.50**

Here's a twin holder for double tom-tom, engineered for maximum adjustments. Exclusive Swiv-O-Matic features permit any playable height and angle adjustment, inter-changeable locations — left, right, rear, or front, close together, spread apart, or any desirable position in-between. Individual height adjustments keep top heads level, even when using two different size tom-toms. Unlimited variations to keep pace with the needs of the modern drummer.

ROGERS KNOBBY UTILITY HOLDER

No. 226R
\$12.50

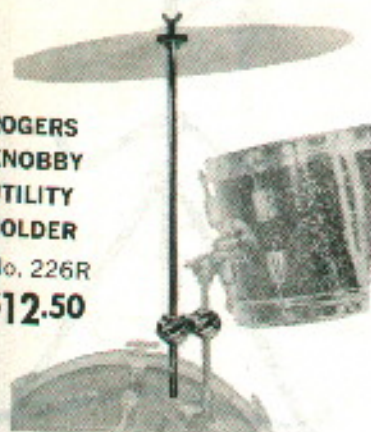

A double Knobby clamp that attaches to any round or hex rod. Illustrated as a cymbal holder, but can be used for other accessories. A fine utility holder with many uses. Complete with clamp and rod.



• PERFECTION •

Perfection "All-Angle" Tom-Tom Holder. Holds any tom-tom at any angle.

No. 1501—Nickel-plated **\$5.00**

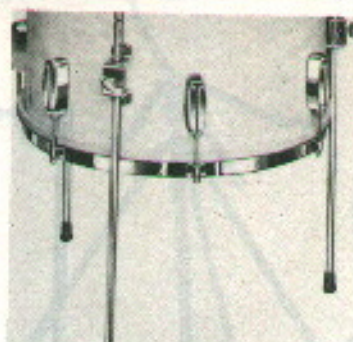

• ROGERS •

TOM-TOM LEGS Chromium Plated

No. 4416-Set of 3, with clamps **\$7.50**

Sturdy steel rods, chrome-plated; rubber tips. Take the place of stand, adjustable to any height; carried on the tom-tom. Legs have position markers notched for even height adjustment.

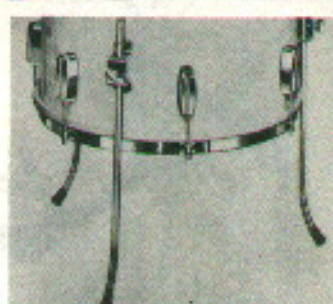

• ROGERS •

"FLARE"

TOM-TOM LEGS Chromium-Plated

No. 4256-Set of 3, with clamps **\$9.75**

Gracefully curved legs, polished and deluxe chrome plated. Legs have position markers notched for even height adjustment. Adds beauty and more balance to tom-tom.

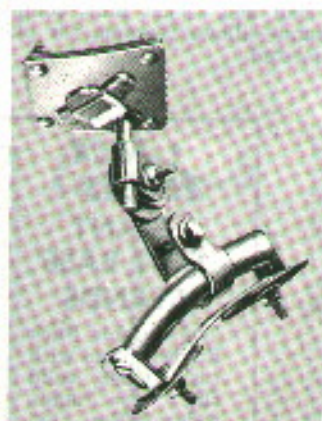

SHELL MOUNT CONSOLE

Adjustable to height and angle. Attached to bass drum shell. Holds tom-tom securely; can be folded down for convenient handling.

No. 1712C — Chrome-plated. Shell mount Console Rail and Tom-Tom Holder assembly. Each, complete **\$12.75**

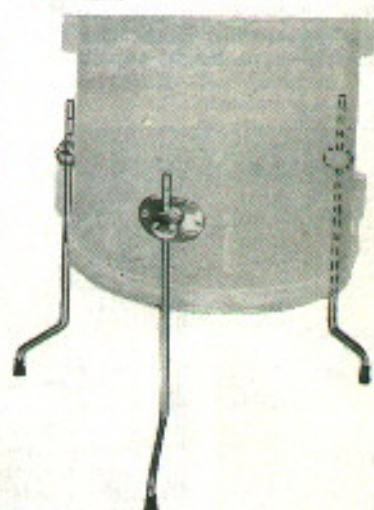

• KNOBBY • TOM-TOM LEGS

Another practical
innovation by Rogers

No. 275R—Chrome Plated. Set of 3 **\$22.50**

DeLuxe polished legs, shaped for maximum sturdiness, wider perch and balance. Hex Tom-Tom legs have position markers notched for even height adjustment. Designed so floor tom-tom can be converted into Cocktail Drum holding snare drum, tom-tom, cymbals, and traps.

• KNOBBY • TOM TOM LEGS

Long Model

No. 276R—Same as above, but longer for 14" floor Tom Tom **\$22.50**

ROGERS

• KNOBBY • UNITS

No. 220R—Utility model, with 4-way cross-grooved trenches to take 3/8" round rods Each **\$5.50**

No. 221R—Special model, with heavier lower clamp section, for 3/8" hex rods. Designed for mounting on floor tom-tom shells, or Cocktail drums to clear flanged hoops Each **\$6.00**

DRUM HOLDERS and STANDS

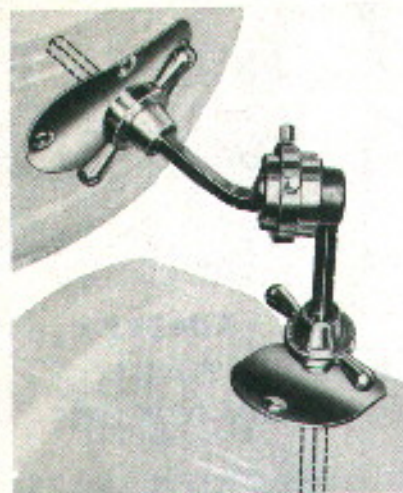

• SWIV-O-MATIC •

No. 380R—Internal Mount for mounting of Snare Drum and/or Tom-Tom on bass drum, Chrome-Plated

\$19.75



ALL-PURPOSE HOLDERS

No. 382R—Shell-Mount for mounting of Snare Drum and/or Tom-Tom on floor tom or cocktail drum, Chrome-Plated

\$19.75

Has all-directional SWIV-O-MATIC ball and socket unit, complete with mounting plates and accessories. Eliminates drum stand—allows freedom for players feet. Extra long hex shaft permits height adjustment, if desired.



FLUSH BASE STAND

No. 4870R—Chromium Plated, Each **\$13.50**

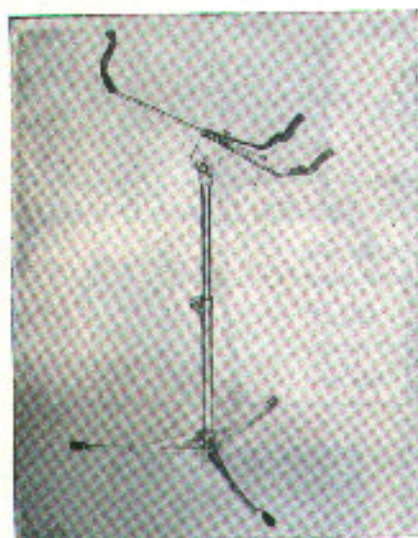

• MARVEL • FLAT BASE

Hugs the floor. Positive angle adjustment. Adjustable to 14", 15", 16" snare drums Rubber tipped legs.

No. 1716C—Chrome-plated Each **\$10.50**

• BUCK ROGERS • GIANT FLAT BASE STANDS

The reliable Buck Rogers stand with the most solid flat base made today. For 14" Drums. Ideal for rim shots. Drum and stand are locked together as a solid unit — no wobble or vibration. Folds compactly.

No. 1718C—Chrome-plated Each **\$19.75**

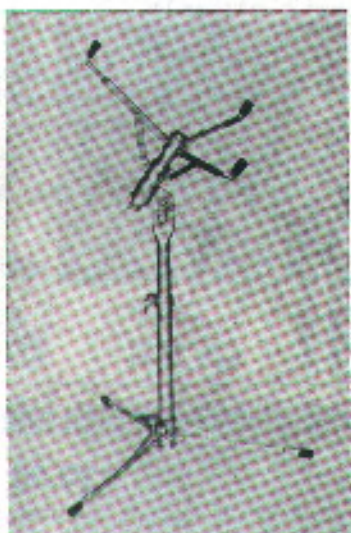

• CAMCO • FLUSH BASE SNARE DRUM STAND Chrome-Plated

No. F800 **\$12.75**

Rigid Tilting—Serrated Arrangement—No Wobble—Folds into compact unit for easy carrying—Light Weight—Special clamping arm that tightens around drum to hold it tight. Fits 13", 14" and 15" drums.



STURDY DRUM STAND

Adjustable to any angle. Folds compactly. Nickel plated. Popular model at a moderate price.

No. 532
Each **\$5.50**



• ROGERS • BASS DRUM CRADLE

No. 4736—Reinforced Wood Each **\$8.95**

Designed to hold all size bass drums securely. Light, compact construction.

Sturdy, Steel Reinforced, Hardwood Doweled Construction.

Compact, Folds to 16"x18"x4" . . . Can be stored in bass drum cover or case.



• SUPER MARVEL •

Adjustable for drums up to 16".
No. 918—Nickel .. Each **\$9.50**
No. 918C—Chrome .. Each **10.50**

DRUM STANDS



• JUVENILE •

A lightweight drum stand made expressly for toy or juvenile drums.

No. 535—nickel Each \$3.75



• NORWOOD • STANDS

Adjustable to hold drum up to 16" diameter. Folds to 18". Bright nickel finish.

No. 100 Each \$4.00



• PERFECTION •

Well built, adjustable for drums up to 16" size. Folds compactly. Nickel plated.

No. 525 Each \$6.95

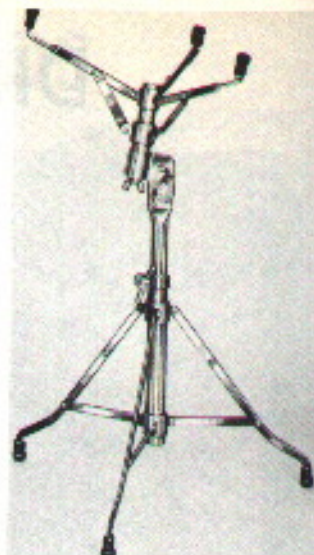

• ROGERS • GIANT STAND

Chrome Plated

A heavy duty stand with newly designed legs that set firmly on the floor. Adjustable clamping arms on top part holds drum in a viselike grip at any angle. For 18" and 14" drums.

No. 4012—Chrome Each \$21.00

No. 4012H—For standing position, chrome \$23.50



• ROGERS • "PRO" STAND

Chrome Plated

A medium weight professional stand with newly designed legs that set firmly on the floor. Adjustable for drums up to 16". Chrome plated.

No. 4011 Each \$12.00



HAMILTON DRUM STAND

For 14", 15", or 16" Drums
Entirely new heavy duty construction. Special devices for positively locking all adjustments. Crutch type rubber feet prevent slipping. Completely chrome plated. Ideal for concert work, standing or sitting.

No. 275 Each \$14.95B



NORWOOD "EMPIRE"

Professional drum stand, extra heavy, for all-around work. Nickel-Plated.

No. 200—Empire .. Each \$9.90

• SUPER MARVEL •

FLAT BASE GIANT STAND

The heavy duty super marvel top on the heavy duty flat base. A real solid stand for the drummer who prefers the flat base model.

No. 1740C chrome \$13.50



• BUCK ROGERS Jr. •

The popular Buck Rogers style drum stand in the medium weight stand. Adjusting screw tightens arms to drum for absolute safety.

No. 1522C—chrome Each \$16.50

HAMILTON • LONE STAR •
Chromium-Plated
Adjustable, has flanged back brace for rigid support. Folds to 13".
No. 9 Each \$4.50B

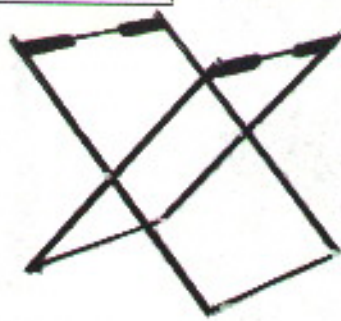

No. 1600 — • PERFECTION • BASS DRUM CRADLE

Sturdy 3/4" steel tubing, nickel finish. Folds compactly.

Each \$19.50

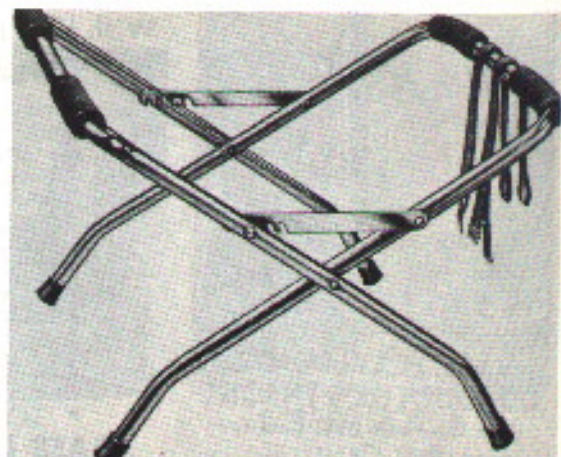

• ROGERS • BASS DRUM RACK

Made of 1" diameter steel tubing, chrome plated. Opens wide to accommodate large bass drums.

No. 4015—Chrome Plated Each \$19.50

DRUM THRONES — LYRES



• ROGERS •

ACCESSORY THRONE

No. 4208—Marine White Pearl, with well padded cushion \$39.50

other colors supplied on special order

This double-duty drum seat is not only a fine, comfortable throne, but also solves trap storage problems. Holds stands and accessories. Standard 24" high.



• DRUMMER'S THRONE •

With Foam Rubber Seat

Professional heavy duty all chrome steel, lightweight, compact. Fast, smooth Acme Thread for sure, safe adjustment from 22" to 28" instantly by spinning seat. Cannot slip! Modern, comfortable foam cushioned seat, white, leatherette cover.

No. 8290—Drummer's Throne Each \$24.00



DRUMMER'S THRONE With Wood Saddle Seat

No. 864—Without back rest, nickel \$15.75
No. 864-B—With back rest, nickel 16.95
No. 864C—Without back rest, chrome 17.75

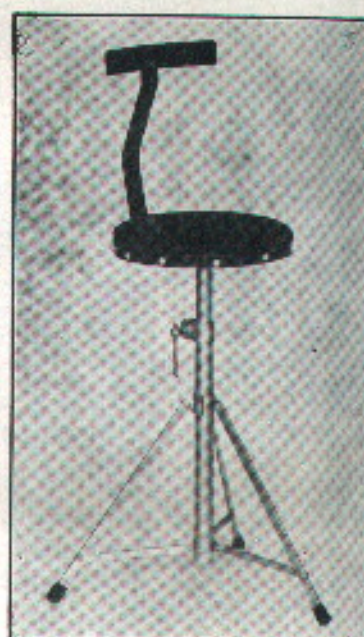

DRUMMER'S THRONE With Round Upholstered Seat

No. 864-1—With back rest, nickel \$17.95
No. 864-2—Without back rest, nickel 16.75
No. 864-2C—Without back rest, chrome 18.75



Chrome-Plated DRUMMER'S THRONE With 12" Padded Seat

No. F9000 Each \$18.00

A well balanced, lightweight throne, with special locking device for different seating height. Sturdy, adjustable, chrome plated metal parts.

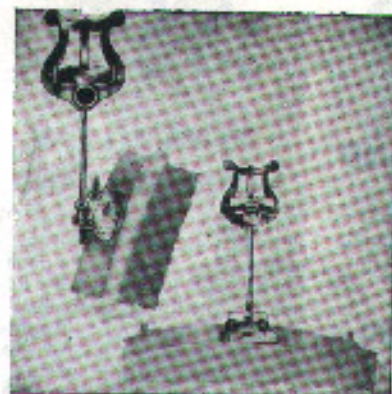

COMBINATION BASS AND SNARE DRUM LYRE

Fastens on bass drum or snare drum rim. Attached or removed in a flash. Holds securely. Made of brass in polished Nickel plated finish.

No. 639 Each \$3.00



No. 635 Snare



No. 637 Bass

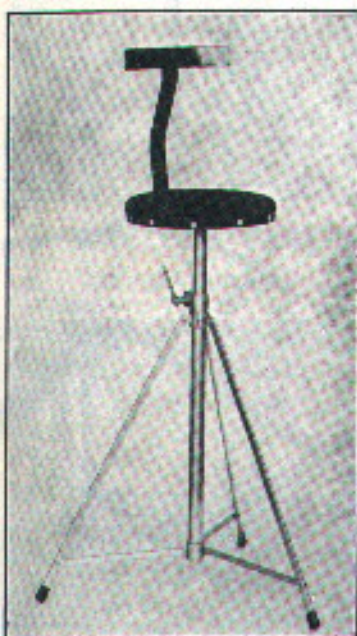

BASS PLAYER'S OR CONDUCTOR'S THRONE

High Base and Heel Rest for Bass Players

(Without heel rest or back rest)

No. 864-5—With round upholstered seat \$17.75

No. 864-7—With plain wood saddle seat 16.75

No. 864-H-R—Heel rest 1.50

No. 864-B-R—Back rest 2.25



BASS DRUM LYRES

No. 638 Each \$6.00

Light in weight and very durable. Fastens on bass drum rods. Adjustable for all sizes. Attached or removed in a flash. Holds securely. Made of brass. Nickel plated.



"ALL PURPOSE" LYRE

No. 4494—Nickel-plated. Ea. \$3.00
Loops around neck, designed for use with any instrument. Attaches quickly — fully adjustable — folds compactly — easy to carry — fits into pocket. Sturdy construction.

DRUM LYRES

With socket to screw on drum. Nickel.

No. 635—For SNARE Drum Doz. \$21.60

No. 637—For BASS Drum Doz. \$21.60

MUFFLERS — PRACTICE PADS



With
Sta-Tite
Hoop Clamp
Chrome
Plated

• ROGERS • MUFFLERS—Professional Model

No. 4439—Professional quality muffer with spring tension screw, permitting full adjustment to any desired pressure and any desired angle. Large metal disc with high grade felt pad. Polished and chrome plated.
Top value ----- Each **\$5.95**



With
Sta-Tite
Hoop Clamp
Chrome
Plated

• ROGERS • MUFFLERS—Popular Model

No. 4435—Adjustable, popular priced Bass Drum muffer with large metal disc and felt pad. Spring-loaded mechanism permits self adjustment to any required angle.
Chrome finish ----- Each **\$4.50**

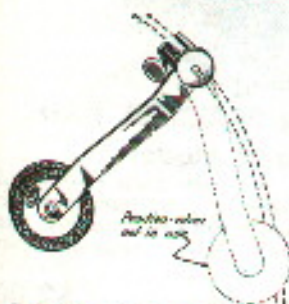

DRUM MUFFLERS

Spring action. Muffer, on or off in a flash.

No. 275—For bass drum. Each **\$3.50**

No. 276—For snare drum. Each **\$2.25**



PRESSURE-TIGHT BASS DRUM MUFFER

Adjustable even pressure can be applied to drum head.
Muffer can swing to right or left to desired position.

An even controlled drum tone is effected with the thumb screw pressure adjustment. We use hardened spring steel, heavy strong clamps, 5" metal disc with thick felt muffer pad. Highly polished red or blue anodized plating.

No. 280 For Bass Drum ----- Each **\$5.00**



• PRESTO • MUFFLERS

No. 990—Bass. ----- Each **\$3.75**



• ROGERS • Internal Tone Control

No. 4440 — Rogers internal tone control. Fits snare or parade drums and tom toms.
Each ----- **\$3.75**



PERFECTION

No. 1448—Internal Snare or Tom-Tom Control.
Each ----- **\$2.50**



HEAVY DUTY PAD SET

Heavy steel stand, with wide legs, adjustable, equipped with popular pad.

No. 1688—Pad and stand, Complete **\$12.00**

No. 1272—Stand only ----- **\$ 7.50**



• RED DOT •

No. 700 ----- **\$1.50**

Size 7"x5½", with gray rubber 4½"x3½" pad. Speckled multi-color finish. Pedestal model, 4 rubber bumpers, cellophane wrapped.



• RED DOT •

No. 600 ----- **\$1.95**

Size 7"x5½", with 5"x4" rubber pad. Pedestal on platform. Speckled multi-color finish. Rubber bumpers. Cellophane wrapped.

INTERNAL BASS DRUM MUFFLERS



Chrome-Plated Fittings

No. 1446C — Single pressure point tone control for one head. Outside fittings chrome plated. Positive control.
Each ----- **\$6.50**

No. 1566C — Double internal control. Has 4 pressure points, 2 for each head. Outside fittings chrome plated.
Each ----- **\$13.00**

No. 1566C—Chrome — **\$13.00**

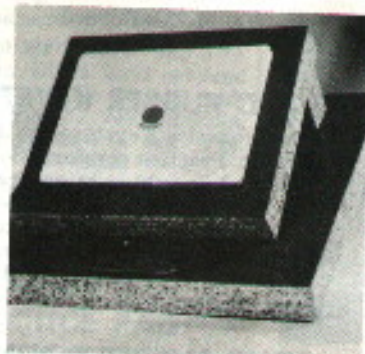

• RED DOT •

No. 300 ----- **\$4.95**

Formica covered pedestal 5¼"x5¼" or formica covered 7¼"x8¼" base. Red Dot rubber pad is 4½"x3½". Rubber bumpers. Cellophane wrapped.

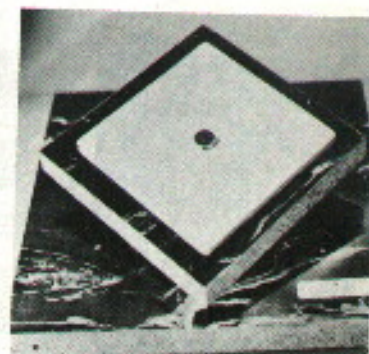

• RED DOT •

No. 100 ----- **\$5.95**

Formica covered 5¼"x5¼" diamond pedestal on 9"x9" formica covered platform. Has 4½"x4½" rubber pad, rubber bumpers. Cellophane wrapped.

DRUM PRACTICE PADS



• COLE • PRACTICE PAD

Pocket - Size

No. C-880—Fits any coat pocket. Size 3 7/8" x 5 1/4". Rubber on both sides—will not slip. Heavy chipboard, red covering.

Each \$1.20

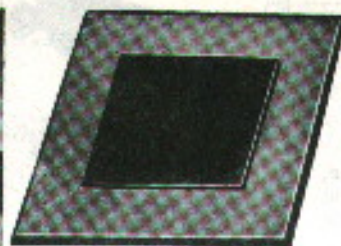

FLAT PRACTICE PAD

Made of chip-board—beautiful red color—7 1/2 x 7 1/2 and 1/2 inch high. Live gum black rubber pad. Beautiful finish—edges beveled.

No. C 818 \$1.15

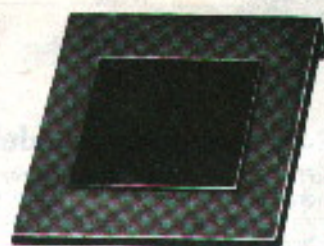

ONE STEP PRACTICE PAD

Made of chip-board—beautiful red color—7 1/2 x 7 1/2. Live gum black rubber pad—block placed on back end of block so that the pad slants. Beveled edges—beautiful finish.

No. C 819 \$1.20



CHIP BOARD PRACTICE PAD

Made of chip board—and covered with a beautiful red-glazed paper. 7 1/2 x 7 1/2. Live gum black rubber pad placed on a sliding platform.

No. C 816 \$1.50



• ECLIPSE • PRACTICE DRUM

Adjusts to proper height and tilt of snare drum.

No. 787—Complete with stand Each \$5.40

No. 787S—Stand only \$3.75
Without Practice Pad



• DRUMETTE JUNIOR •

The practice pad with added features! Will fit into music stand by means of a rod which screws into the bottom of the pad. May be used on any level surface also. Rubber feet keep it in place. Compact, light, easy to carry, made of hand cast aluminum.

No. 7394 Drumette Junior Practice Pad only (without rod) \$2.95B

No. 7393—Rod only for Drumette Jr. Practice Pad (fits into music stand) Each \$1.25B



HI-SPOT DRUM PRACTICE PAD

Tilted model, made of heavy hardwood, beveled edges, lacquered. 6" x 4 1/4" heavy rubber pad on a 7" x 5 1/4" top.

No. M-75—Drum Practice Pad Ea. \$1.90
Dozen lots only \$18.00 Doz.



WOODEN PRACTICE PAD

Round Model

Hard maple, lacquer finish. Base consists of two wooden supporting cleats, on to which the round wooden fixture and rubber pad are mounted. Rubber is 7 inches in diameter and 3/8" thick.

No. C1853 Each \$3.00



WOODEN PRACTICE PAD

Professional Model

Beautiful hand finished hardwood, blonde lacquer finish. Countersunk 1/4" thick rubber pad flush with face of pad. Set at 30 degree angle. Place to store sticks in back of pad. Fine quality beveled edges.

No. C1885 Each \$4.50



SOLID RUBBER KEYSTONE PRACTICE PAD

Perfect Practice Keystone Style Drum Practice Pad is the latest design in Practice comfort. Scientifically molded of live, black 55 durometric rubber to assure lively bounce.

Each Pad is tapered 1 inch to 3/4 inch and is 4 1/4 inches wide at the widest point of the Keystone and 4 1/2 inches long. Packed in a beautiful blue and silver display set up box.

No. A-32—Keystone Each \$2.50

SOLID RUBBER ROUND PRACTICE PAD

Perfect Practice Round Drum Practice Pad is Scientifically designed to give both professional and amateur the ultimate in practice comfort.

Each pad is one-piece moulded black rubber 4 1/4 inches in diameter wedged 1 inch tapering to 3/4 inch for true, lively drum practice performance.

Packed in a beautiful blue and silver display set up box.

No. A-31—Round Each \$2.25



• WEATHER-KING • DRUM PRACTICE PADS

Designed and developed by leading professionals to accurately simulate the feeling of an actual drum. Also recommended for brush practice.

Manufactured in 4 sizes to meet the requirements of the most discriminating drummers, professionals and students alike.



No. RP4 — Weather-King Pad, 10" size, on base --- Each \$6.95

No. RP3 — Weather-King Pad, 8" size, on base --- Each \$5.95

No. RP2 — Weather-King Pad, 6" size, on base --- Each \$3.95

No. RP1 — Weather-King Pad, 6" Jr. Tilted, no base Each \$2.95



ROGERS "PRO" PRACTICE PAD

Many prominent teachers advocate the use of these flat top practice pads. With non-skid base.

No. 7397 ----- \$4.50



ROGERS RUBBER PRACTICE PAD

Use this 6" rubber disk as an extra. Carry it in your pocket and use it whenever you want to practice.

No. 7398 ----- \$1.75

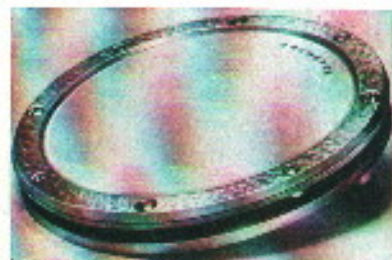

• DRUMETTE • PRACTICE PAD

Made of durable cast aluminum in compact 6 inch size. Only 1 1/2 inches high. Tunable, with genuine calfskin head. Fits music stands. Quiet, practical, real drum action.

No. 7395 — Drumette Pad, complete with rod which screws into bottom of pad \$5.95 and fits into music stand ----- Each



• WEATHER KING • PRACTICE PAD SETS

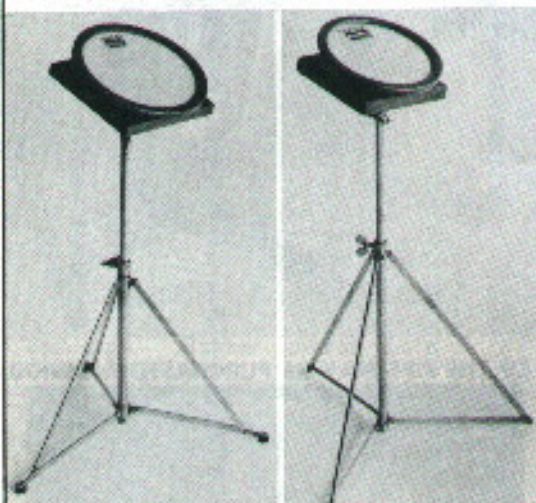

No. 7389

No. 7390

No. 7389 — 10" Pad with heavy duty adjustable stand ----- \$16.95

No. 7390 — 6" Pad with lightweight adjustable stand ----- 9.95

RUBBER PRACTICE TIPS

For Individual or Classroom.



Rubber "hoods" slip over tips. Gives good rebound for practice without pad. Specially recommended for classroom use. Fits any size stick.

1756 — Pair ----- \$3.30

POPULAR PRACTICE PAD

The ideal pad for — Professional — Teacher or Pupil. Used and recommended by America's finest drummers. Base in natural wood, 7"x5". Bright red resonator. Lively rubber top in black. Beautiful three-color combination.

No. 1601 ----- Each \$1.95



• PEP • DRUM PRACTICE PAD

Compact, easy to carry, easy to use. Made of brightly colored one piece rubber. Scientifically slanted for proper use. Size is an ideal 5 1/2 inches.

No. 7396 — Pep Practice Pad --- Each \$2.25



DE LUXE PAD

Strongly built, heavy, will not move. Base: 7 3/8" wide, 7" long Top: 5 1/2" wide, 5 1/2" long. Black rubber pad. The wooden practice pad is heveled, and scored very attractively. Will not scratch any surface. Red and white combination.

No. C817 ----- Each \$3.24

• FIPS • SILENT PRACTICE DRUMS

True Size - True Feel - Without Sound

(Patented)

VERSATILE:

The FIPS can be easily adjusted to duplicate any drum set-up.

SILENCE IS KEYNOTE:

For the first time in drumming history, the disturbing sound is gone. No more complaining neighbors. The whisper-volume of FIPS makes it ideal for day or night practice at home.

TEACHER'S DELIGHT:

Because of its sound-control, light weight and flexibility, FIPS is ideal for classroom and home instruction.

LOW COST:

Its attractive low price brings the FIPS Practice Drum Set within reach of all serious-minded drummers — student and professional, alike.

DRUM HEAD PERFECTION:

Drum heads have been scientifically developed and perfected by one of our country's leading drummers. The FIPS snare drum, bass drum and tom-toms have reversible surfaces providing sound control from soft to softer. The FIPS unique cymbal muffers are made of an elasticized material which muffles cymbal sound.



JIM CHAPIN AT HIS FIPS

**No. 4881
COMPLETE SET
\$79.50B**

Includes:

No. 4882—Bass Drum	\$30.70B
No. 4884—Snare Drum	15.50B
(with stand)	
No. 4885—Large Tom Tom	20.30B
(with adj. legs)	
No. 4888—Small Tom Tom	12.65B
(with holder)	
No. 4889—Cymbal Holder and clamp	4.75B
No. 4886—Cymbal Muffers (2)	4.70B
No. 4887—Cymbal Muffler (1)	2.65B
Total Value	\$91.25B

LIGHT-WEIGHT, COMPACT AND STURDY:

All metal parts of the FIPS Drum Set are made of top grade aluminum and steel. All metal parts have durable high quality finish. Drum heads are made of special DuPont "Mylar", guaranteed not to split, crack or tear. Reversible sides are made of sturdy sponge rubber. The entire set is pre-packaged in a small corrugated box for your convenience.

PARTS OF THE FIPS MAY BE PURCHASED INDIVIDUALLY.



• FIPS • BASS DRUM

20 inches in diameter. Rim is of metal, gold finish. Built-in adjustable spurs with rubber tips.

No. 4882—FIPS Bass Drum **\$30.70B**
Each



• FIPS • TOM-TOM 16" with adjustable legs

Metal rims with high quality gold finish. Two playing sides, detachable legs that are adjustable for height. Can be used with sticks or brushes.

No. 4885—FIPS 16" Tom-Tom with adjustable legs—Each **\$20.30B**



• FIPS • SNARE DRUM PAD 14"

The unique design of the FIPS Snare Drum Pad allows it to fit inside the rim of your snare drum as well as on a stand by itself. Engineered to protect all surfaces. Can be used with sticks or brushes.

No. 4883—FIPS Snare Drum Pad without stand Each **\$12.00B**



• FIPS • CYMBAL HOLDER with clamp

Metal, gold finish, built in cymbal tilt.

No. 4889—Cymbal Holder with clamp Each **\$4.75B**



• FIPS • SNARE DRUM PAD with stand

Metal rims with high quality gold finish. Two playing sides, designed to be used on a snare drum stand or on top of snare drum. Can be used with sticks or brushes.

No. 4884—FIPS Snare Drum Pad with metal stand—Each **\$15.50B**



• FIPS • TOM-TOM 12" with adjustable holder

Metal rim with gold finish, two playing sides. Adjustable holder that attaches on to FIPS console. Can be played with sticks or brushes.

No. 4888—FIPS Tom-Tom, 12" with adjustable holder—Each **\$12.65B**

• FIPS • CYMBAL MUFFLERS

Made of durable, elasticized material, designed to conform to the edge of the cymbals. Two sizes.

No. 4886—Small, fits cymbals from 12" to 16" **\$2.35B**
Each

No. 4887—Large, fits cymbals from 16" to 20" **\$2.65B**
Each



DRUM BRUSHES



**• ROGERS •
BUDDY RICH
WIRE DRUM BRUSHES**

Rubber covered
aluminum tubing

Loop end
with
narrow spread

No. 940R
Per Pair **\$1.75**

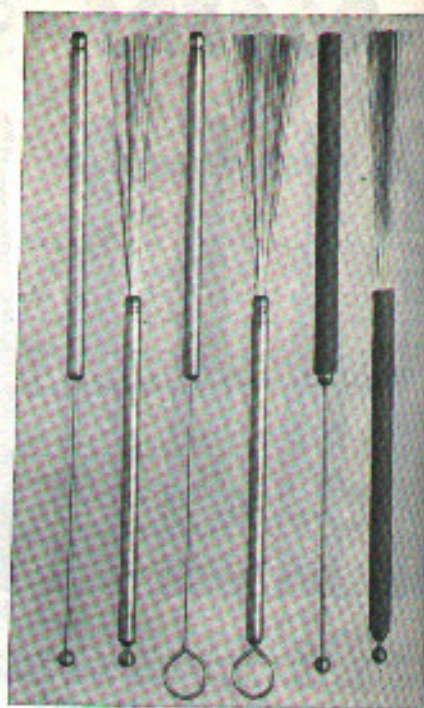

FAVORITE PLASTIC MODEL

A favorite model, preferred by practically all drummers. Flared ends, black plastic sleeve, white plastic knob. No. 4608—Jazz Brushes ----- Pair **\$3.50**

• ROGERS • WIRE DRUM BRUSHES

Especially Designed For Rim Shots

Drummers, who need tough, sturdy, high grade brushes, need look no further. Here, at last, are brushes that stand up and resist denting. Suitable for French Bands. Genuine BRASS handles.

LOOP ENDS
No. L242R—Brass Handles, nickel-plated. ----- Pair **\$2.10**
No. L243R—As above, rubber covered. ----- Pair **2.25**

BALL ENDS
No. B242R—Brass Handles, nickel-plated. ----- Pair **\$2.20**
No. B243R—As above, rubber covered. ----- Pair **2.35**

• STEREO • BRUSHES

For the drummer who wants a brush with narrow spread for cymbal, drum and tom tom whip accents. Solid brass tubing handles resist denting.

Per Pair
No. 946B—Brass handle, brass ball ----- **\$2.10**
No. 946L—Brass handle, loop end ----- **2.10**
No. 947L—Rubber covered brass, loop end -- **2.35**
No. 947B—Rubber covered brass, ball end -- **2.35**



Wood handle
No. 210
Pair.....**\$1.80**



Loop end
No. 212
Pair.....**\$2.85**



Ball end
No. 213
Pair.....**\$2.85**



RUBBER COVERED
Rubber covered, Loop ends,
No. 212RC
Per Pair**\$3.00**

Rubber covered, Ball ends,
No. 213 RC
Per Pair**\$3.00**

ROGERS Two-Way Clamp Attachment

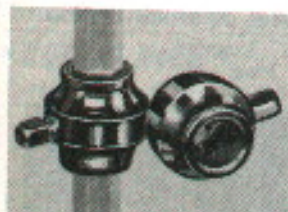

No. 281R—Clamp for use on Rogers stick tray and adjustable Cowbell Holder assemblies -- Each **\$2.00**

ROGERS Stick Tray Clamp



No. 284R—Clamp for use on Hi-Hat stick tray assembly --- Each **\$3.00**

• ELTON • PLASTIC HANDLE

Drum stick size, perfectly balanced. Bright plated wires, telescope into handle. Boxed. Black highly polished.

No. Per Pair
217 Loop type **\$2.85**
218 Ball end type **3.00**

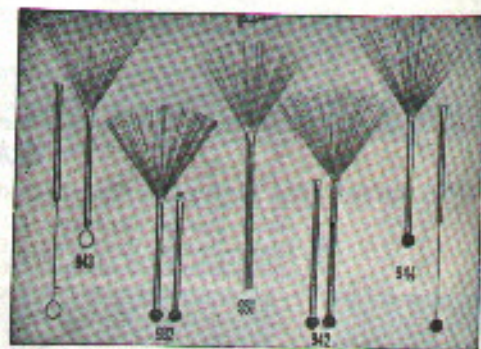

• PERFECTION • WIRE BRUSHES

No. Pair
931 —Wood handle **\$1.05**
943 —Loop end **1.50**
943RC —Rubber covered, loop end **1.75**
944RC —Rubber covered, rubber ball end **1.85**

• ROGERS • STICK TRAYS

Here is the necessary every drummer has been waiting for. Holds a good supply of sticks, brushes and beaters. Eliminates fumbling and puts them at your fingertips. Adjustable to any height and angle. Easy to attach.



No. 287-R ASSEMBLY
Attaches to tom-tom leg ----- Each **\$10.50**



No. 286-R TRAY
Attaches to any type cymbal rod. Ea. **\$6.75**



No. 288-R ASSEMBLY
Attaches to Hi-Hat Sock Pedal. Ea. **\$11.50**

• ROGERS • STANDARD DRUM STICKS

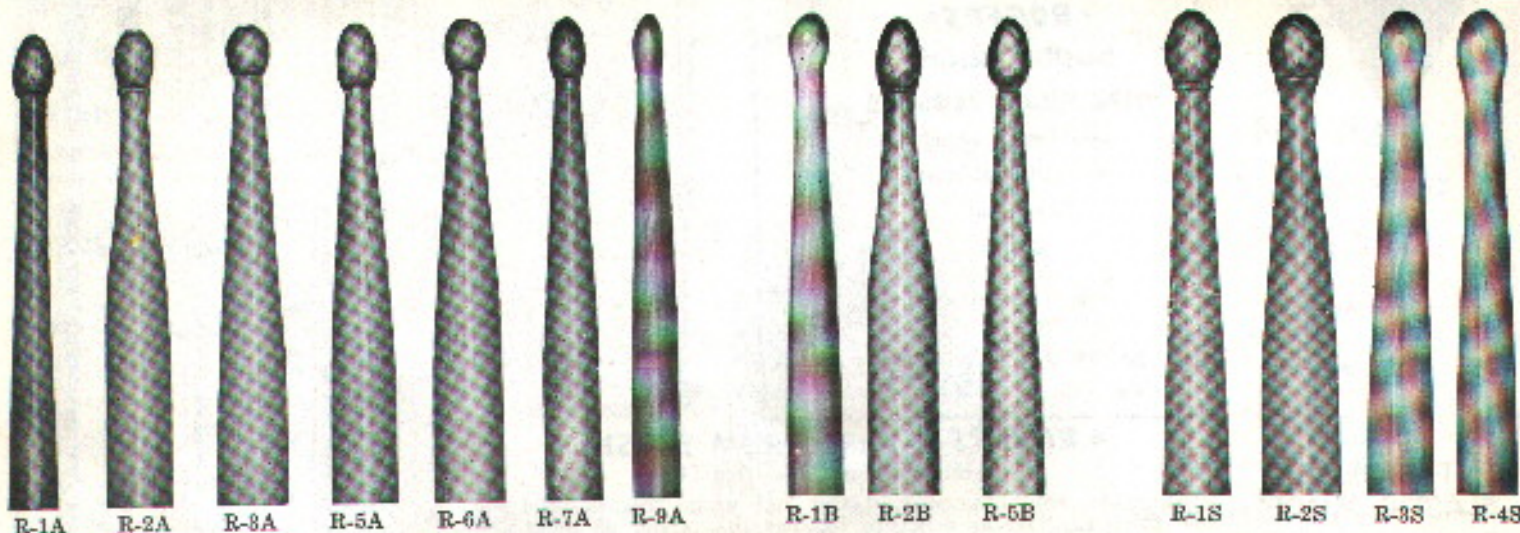

Precision made, carefully filled, smoothly finished and high-lustre lacquered to professional "feel". Rogers sticks are tested for proportion and balance. Each stick stamped with Rogers name and number.

"ORCHESTRA" MODELS

For snare drumming and all-around jobbing. Fine selection of "A" models.

No.	Length	Weight (pr.)
R-1A	About 16 1/2"	3 3/4 oz.
R-2A	About 16"	3 3/4 oz.
R-3A	About 15 1/2"	3 1/2 oz.
R-5A	About 16"	3 oz.
R-6A	About 15"	3 1/2 oz.
R-7A	About 15 1/4"	2 1/2 oz.
R-9A	About 15 1/4"	2 1/4 oz.

Per Pair
\$1.00

"BAND" MODELS

These are the popular "B" styles, ideally suited for inside band or concert work. For all-around use, 2B is the most recommended choice.

No.	Length	Weight (pr.)	Per Pair
R-1B	About 16 1/2"	4 1/4 oz.	\$1.00
R-2B	About 16"	4 1/2 oz.	
R-5B	About 15 3/4"	3 1/2 oz.	

Weights and lengths listed are subject to slight variations.

"PARADE" MODELS

For outdoor use. Ideal for drum corps marching or street parade work, with either 1S or 2S recommended. No. 3S is a heavy practice model. No. 4S is longer.

No.	Length	Weight (pr.)
R-1S	About 17"	5 1/2 oz.
R-2S	About 17"	6 1/4 oz.
R-3S	About 16 3/4"	6 1/2 oz.
R-4S	About 17 1/4"	5 1/2 oz.

Per Pair
\$1.00

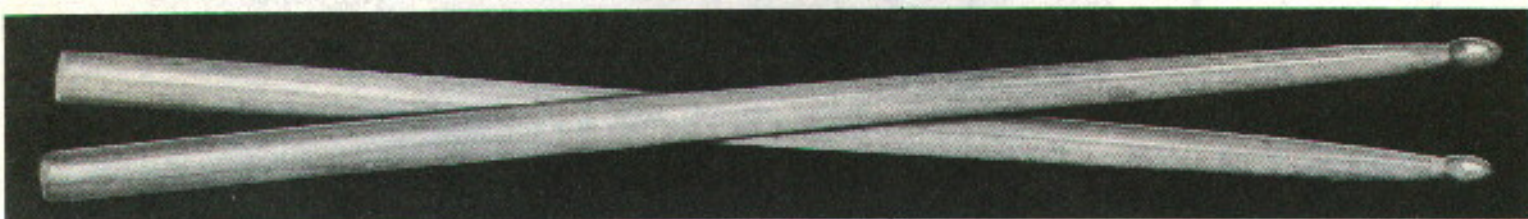

• DIXIE • SUPER QUALITY DRUM STICKS

Specially selected high gloss finished sticks, each pair in a cellophane bag, 6 pairs of each model in stock carton.

No. D2A—Dance, Orchestra, 15 1/2" long	} \$1.25 Pair
No. D5A—Dance, Orchestra, 16" long	
No. D8A—Dance, Orchestra, 16" long	

No. D7A—Jazz, Orchestra, 15 1/2" long	} \$1.25 Pair
No. D2B—Band, Concert, 15 3/4" long	
No. D11A—Dance, Orchestra, 15 1/2" long	

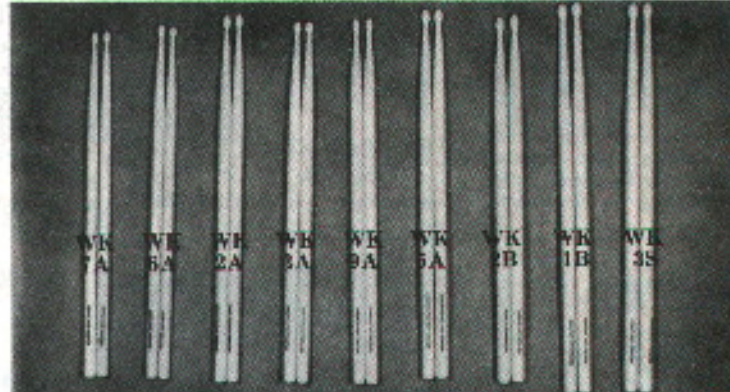

WEATHER KING • DURALAM • STICKS

NINE DIFFERENT MODELS — EACH PAIR IN PLASTIC BAG

WK3S- IMPERIAL for Marching, 17", 3 oz.	} \$2.45 Per Pair
WK1B- PRESIDENT for Marching and Concert Band, 16 1/2", 2 1/2 oz.	
WK2B- STADIUM for Marching and Concert Band, 18", 2 1/2 oz.	
WK6A- PHILHARMONIC for Concert Band and Orchestra, 15 3/4", 2 oz.	
WK3A- CONCERT for Band and Orchestra, 15 3/4", 1 3/4 oz.	
WK9A- SYMPHONY for Concert Band and Orchestra, 15 1/2", 1 3/4 oz.	
WK2A- PALLADIUM for Concert Band and Orchestra Dance Band, 15 1/4", 1 1/2 oz.	
WK6A- SAVOY for Dance Band and Combo, 15 1/4", 1 1/2 oz.	
WK7A- COMBO for Small Band, 15", 1 1/2 oz.	

WEATHER KING DRUM STICKS are made of a special REINFORCED PLASTIC material, developed specifically for this use.

The sticks will NEVER warp — Will resist cold, heat and moisture. Perfect Balance.

Each stick in a pair is of the same weight. Sticks can be washed clean after use.

Hard surface will resist chipping and nicking up to five or six times better than wood.

Drum section will always make a fine appearance. Student will take more active interest in his playing.

• ROGERS • STAR LINE HICKORY STICKS

Rogers balanced drum sticks are made from fine second growth hickory, thoroughly seasoned and selected for even, straight grain. Precision made, carefully filled, smoothly finished and high-lustre lacquered to professional "feel". Rogers sticks are tested for proportion and balance. Each stick stamped with Rogers name and number.

"ORCHESTRA" MODELS







For dance work, combo and all-around jobbing. This is a fine selection of premium quality sticks, ideal for all types of snare drumming in dance bands or school orchestras.





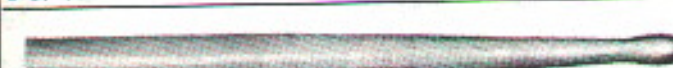

"BAND" MODELS

These are the popular "B" styles, ideally suited for inside band or concert work. For all-around use, 2B is the most recommended.

"PARADE" MODELS

For outdoor use. Ideal for drum corps marching or street parade work, with either 1S or 2S recommended. No. 3S is a heavy practice model. No. 4S is longer.

	No. 1A Star—Dance or Orchestra, 16 $\frac{3}{4}$ ", pair	\$1.50
	No. 2A Star—Dance or Orchestra, 16", pair	\$1.50
	No. 3A Star—Dance or Orchestra, 15 $\frac{1}{2}$ ", pair	\$1.50
	No. 5A Star—Dance or Orchestra, 16 $\frac{1}{8}$ ", pair	\$1.50
	No. 6A Star—Dance or Orchestra, 15", pair	\$1.50
	No. 7A Star—Dance or Orchestra, 15 $\frac{1}{4}$ ", pair	\$1.50
	No. 9A Star—Pee Wee or Pencil, 15 $\frac{1}{4}$ ", pair	\$1.50

	No. 1B Star—Band, Concert, Orch., 16 $\frac{3}{4}$ ", pair	\$1.50
	No. 2B Star—Band, Concert, Orch., 15 $\frac{7}{8}$ ", pair	\$1.50
	No. 5B Star—Band, Concert, Orch., 16 $\frac{1}{8}$ ", pair	\$1.50
	No. 1S Star—Parade and Street, 16 $\frac{7}{8}$ ", pair	\$1.50
	No. 2S Star—Parade and Street, 17", pair	\$1.50
	No. 3S Star—Practice and Parade, 17", pair	\$1.50
	No. 4S Star—Practice and Parade, 17 $\frac{1}{4}$ ", pair	\$1.50

• BUDDY RICH •

No. "BR" Star
Pair
\$1.50



Best all-around model, most popular for dance band work, combos, cymbals. 15 $\frac{1}{2}$ " long.

• LOUIS BELLSON •

No. "LB" Star
Pair
\$1.50



A well designed medium long model for exacting work on drums, toms, cymbals. 16 $\frac{1}{2}$ " long.

• COZY COLE •

No. "CC" Star
Pair
\$1.50



Popular seller with great appeal for all drummers. Ideal weight and size. Well balanced, 16" long.

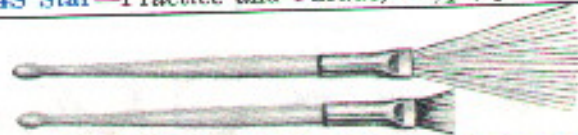

• LOUIS BELLSON • STICK BRUSHES

No. 4671—A practical combination of good drum sticks and TELESCOPING brushes. Unusual but useful for quick change to either stick or brush work.

Per pair **\$3.00**



• LOUIS BELLSON • TAMBOURINE STICKS

No. 4672—A clever accessory, ideal for Latin American dance work. Jingles mounted on Bellson drum sticks.

Per pair **\$2.50**



• STANLEY KRELL • COMBINATION

No. 4673—DeLuxe hickory drum sticks with felt on handle ends. Excellent for specialty work.

Per pair **\$2.50**



• ROGERS • DRUM BEATERS

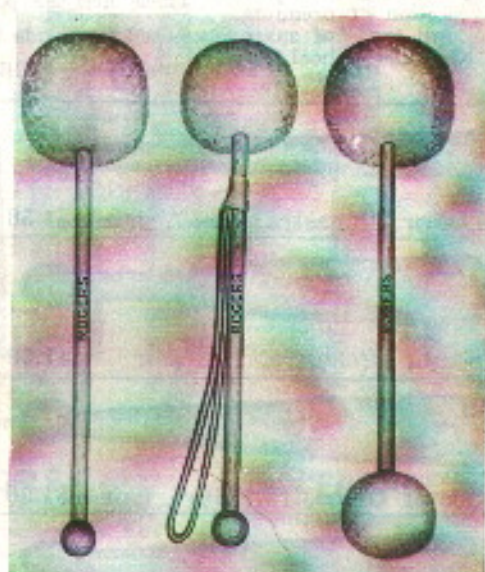
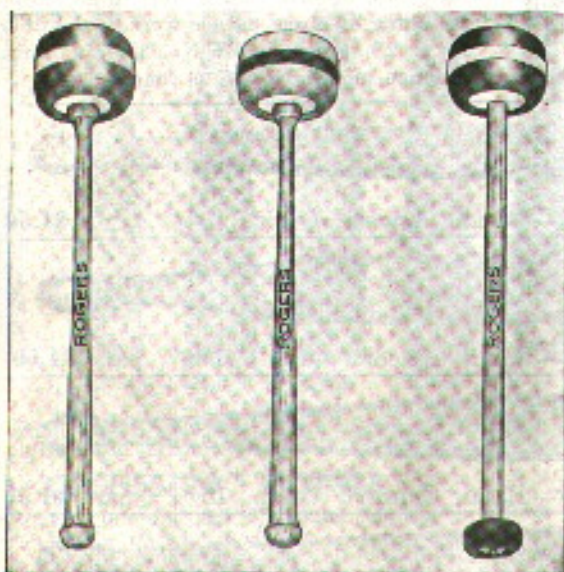

No. 4825
\$3.90

No. 4821
\$4.50

No. 4823
\$4.80

No. 4820
\$6.50

No. 4826
\$5.25

No. 4824
\$6.25

No. 4827
\$5.70

No. 4828
\$6.00

POPULAR • ROGERS • BASS DRUM BEATERS — NATURAL FINISH

Genuine Hickory Handles — Professional Quality

With Felt Balls

Each

- No. 4825—Good grade grey felt, 3-ply, with white center. Length 12½" overall; head diameter 2½" ----- **\$3.90**
- No. 4821—High grade white felt, 3-ply, with green center. Length 12½" overall; head diameter 2½" ----- **4.50**
- No. 4823—Double end model. Good quality grey felt, 3-ply with white center. Length 14" over-all; top head diameter 2½"; bottom head 1¾" ----- **4.80**
- No. 4820—High quality 3-ply grey felt ball with white center. Lamb's wool grip, leather loop. Length 12½" over-all; head diameter 2½" ----- **6.50**

With Lamb's Wool Balls

Each

- No. 4826—Lamb's wool ball, single end. Length 15" over-all; head diameter 3" ----- **\$5.25**
- No. 4824—Lamb's wool, single end, with leather loop. Length 15" over-all; head diameter 3" ----- **6.25**
- No. 4827—Lamb's wool, double end. Length 15½" overall; top head diameter 3"; bottom head 2" ----- **5.70**
- No. 4828—Lamb's wool, double end, Concert Model, larger balls and longer handle. Length 17"; top head diameter 3¾"; bottom head 2¾" ----- **6.00**

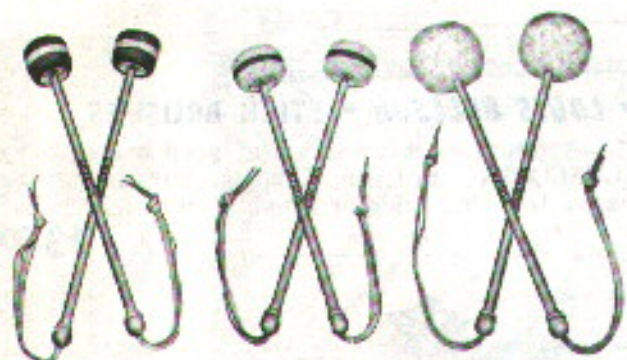

No. 4829
\$6.50

No. 4830
\$7.50

No. 4822
\$7.95

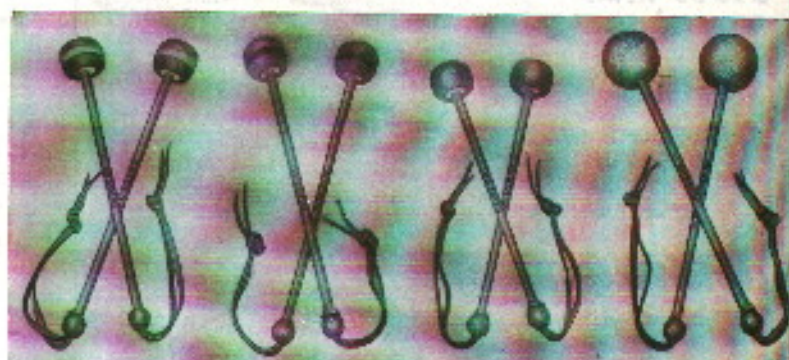

No. 4831
\$6.00

No. 4834
\$6.95

No. 4835
\$6.50

No. 4832
\$7.50

• ROGERS • SCOTCH DRUM BEATERS

Genuine Hickory Handles—Professional Quality

- No. 4829—Good grade grey felt, 3-ply, with white center, leather thongs. Length 14" over-all; head diameter 2½" ----- **Pair \$6.50**
- No. 4830—High grade white felt, 3-ply with green center, leather thongs. Length 14¼" over-all; head diameter 2½" ----- **7.50**
- No. 4822—Lamb's wool ball, with leather thongs. Length 14½" over-all; head diameter 2¾" ----- **7.95**

• ROGERS • TENOR DRUM BEATERS

Genuine Hickory Handles—Professional Quality

- No. 4831—Good grade grey felt, 3-ply, with white center, leather thongs. Length 12¾"; head diameter 1¾" ----- **Pair \$6.00**
- No. 4834—High grade white felt, 3-ply, with green center, leather thongs. Length 12¼"; head diameter 1¾" ----- **6.95**
- No. 4835—High grade solid white felt ball, leather thongs. Length 12"; head diameter 1¾" ----- **6.50**
- No. 4832—Lamb's wool ball, leather thongs. Length 13"; head diameter 2" ----- **7.50**



ROGERS TYMPANI BEATERS



Genuine hickory handles, gracefully tapered, accurately balanced.
Beautiful lacquered finish. Heads guaranteed to stay on.



No. 4841



No. 4843

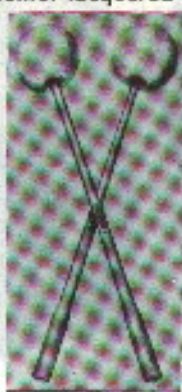

No. 4845

ROGERS TYMPANI STICKS

Genuine Hickory — Tapered Handles

No. 4841 — Solid felt heads. Suitable for tympani rhythm work (also for tom-toms and cymbals). 13" overall, 1 1/4" head ----- Pair \$4.95

No. 4843 — Piano felt over solid felt core. Ideal for fast action, staccato playing, and keen response. 13 1/2" overall, 2" head ----- Pair \$6.00

No. 4845 — Lamb's wool covered head. Artist model, designed for leverage, balance and playing ease. 18 1/2" overall, 2 1/4" head ----- Pair \$6.30

UTILITY

FELT MALLETS

Inexpensive model, for tympani, tom tom or rhythm work.

No. 1166 -- Pair \$1.95

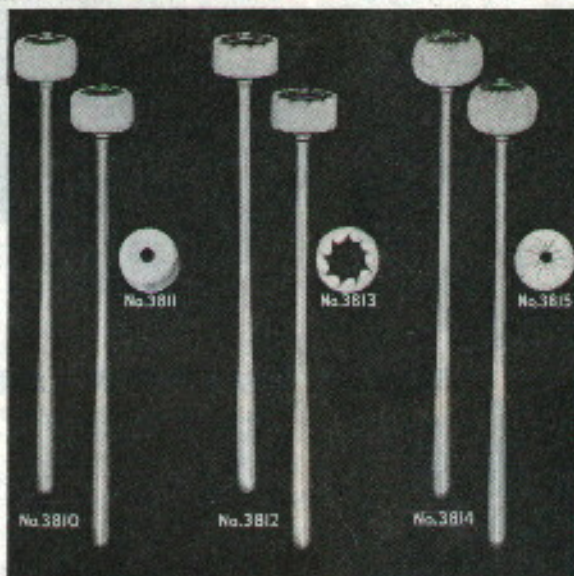
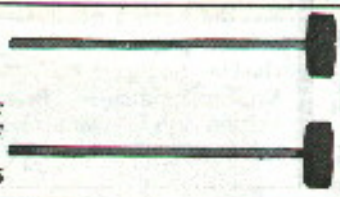

ROGERS TYMPANI STICKS

With Demountable Heads

Genuine hickory, tapered handles, accurately balanced. Special locking device permits replacement of heads simply and easily.

No. 3810 — Solid felt head, 1 1/4" diameter, 14 1/4" overall ----- Pair \$5.70

No. 3812 — Cartwheel, covered with soft piano felt on beating surface, 1 1/4" diameter, 14 1/4" overall ----- Pair \$6.75

No. 3814 — Piano felt, fully covered head, hand sewn, 2" diameter, 14 1/4" overall ----- Pair \$6.90



Demountable Stick Assembly



No. 3820 No. 3819

PARTS for Demountable BEATERS

No. 3819 — Washers, Chrome Plated, Pair .35

No. 3820 — Hexagonal nut, threaded, chrome, Pair .25



DEMOUNTABLE HEADS

No. 3811 — Heads for No. 3810 sticks, Pair \$2.40

No. 3813 — Heads for No. 3812 sticks, Pair 3.30

No. 3815 — Heads for No. 3814 sticks, Pair 3.60

FAMOUS GREAT DANE FIBER GLASS BEATERS & MALLETS

GREAT DANE Felt Drum Beaters have smartly shaped heads made from high quality felt and are reinforced with cork cores for retaining their shape. Head ends are white felt, flanking a grey center washer, bordered with red pencil stripes. The tapered handles are custom made from fiber glass rod (not plastic) for durability and strength. Thongs are held securely to the handles by means of a special retaining ring inserted in the ball end. (PATENTS PENDING)



GREAT DANE MARIMBA MALLETS

Professional marimba mallets. Larger heads and medium tension wound, for mellow tone. Handles have longer shanks to render resilience necessary for vibrato playing. Soft grade is standard. Head color—Garnet red yarn. Overall length 14".

No. 4836 — Standard model Marimba Mallets ----- Pair \$5.50

GREAT DANE VIBRAHARP MALLETS

The Great Dane Professional Vibraharp Mallets are the standard in percussion mallets. Heads are tightly wound to produce sparkling, crispy tone quality. Meticulously made and inspected. Available in three grades: Soft, Medium, and Hard. Overall length 14".

No. 4837S—Soft, Grey Yarn ----- } Pair \$5.50
4837M—Medium, Blue Yarn ----- }
4837H—Hard, Black Yarn ----- }

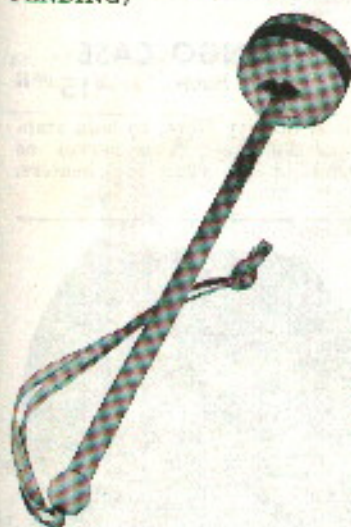

BASS DRUM BEATERS

No. 4840—Large 2 1/4" head, length overall 18 1/4". Each \$5.75



SCOTCH BASS DRUM BEATERS

No. 4839—Head diameter 2 1/4", length overall 12". --Pair \$9.50



TENOR DRUM BEATERS

No. 4838—Head diameter 1 1/4", length overall 11 1/4" Pair \$8.50

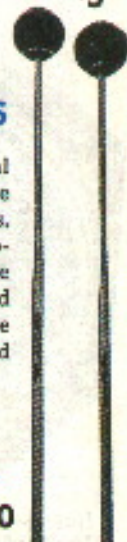

DRUM CASES

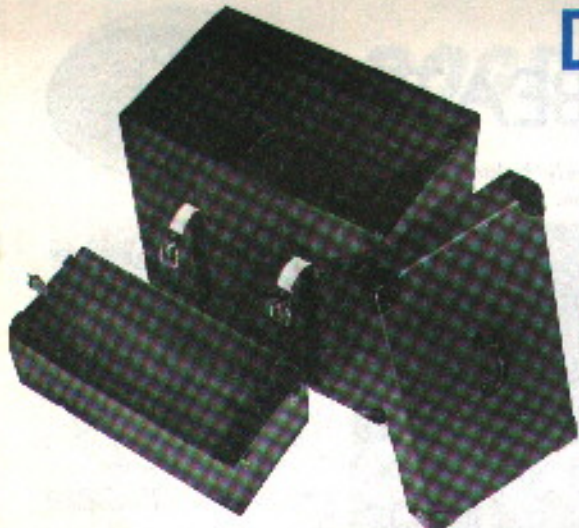

FIT-ALL DRUM CASE

No. 21—With Cymbal Pocket **\$33.50B**

22 1/4" Long; 10 1/2" Wide; 22 1/4" Deep

Versatile, handy, convenient and practical. Fits cymbals, drum and traps. Holds any size snare drum in one 16" x 8" x 16" compartment. Another compartment size 7" x 8" x 15" fits accessories. Extra large tray size 22" x 7 1/2" x 7" holds assorted traps. Specially designed 22 1/4" x 2 1/2" x 22" compartment is provided for large cymbals up to 22" in diameter. Case is hard vulcanized fibre, with reinforced metal corners. Equipped with heavy duty hardware, plastic handle, and two heavy leather straps.

No. 21W—With WHEELS, as above **\$39.50B**



SNARE DRUM CASES

Flat bottom. One leather strap. Leather handle. Made of best grade of hard vulcanized fibre. Strongly riveted.

No. 50—For 14" Snare **\$12.50B**

No. 51—For 15" Snare **\$13.50B**

TOM-TOM CASES

No. 812—For 8x12 Tom..... **\$12.50B**

No. 913—For 9x13 Tom..... **\$13.50B**

No. 1414—For 14x14 Tom..... **\$16.50B**

No. 1614—For 16x14 Tom..... **\$17.00B**

No. 1616—For 16x16 Tom..... **\$17.50B**

No. 1316—Combination for 16x16 and 9x13 Toms **\$32.50B**

PARADE DRUM CASES

No. 1014—For 14" Parade..... **\$14.50B**

No. 1215—For 15" Parade..... **\$16.50B**

No. 1216—For 16" Parade..... **\$17.50B**

BASS and SCOTCH DRUM CASES

Flat bottom. Three leather straps

No. 1420—For 14" x 20" Bass Drum **\$29.50B**

No. 1222—For 12" x 22" Bass Drum **30.00B**

No. 1422—For 14" x 22" Bass Drum **30.00B**

No. 1424—For 14" x 24" Bass Drum **31.00B**

No. 2610—For 10" x 26" Scotch Drum **31.50B**

No. 1426—For 14" x 26" Bass Drum **31.50B**

No. 2810—For 10" x 28" Scotch Drum **32.00B**

No. 1428—For 14" x 28" Bass Drum **33.50B**



No. 30—Snare Drum Case-Each **\$18.00B**

28" Long; 16 1/2" Wide; 10" Deep

Light weight durable case. Will hold any size snare drum. Has adjustable partition made of the best grade of hard, vulcanized fibre. Heavy hardware, leather handle. Strongly riveted. Will withstand hard usage.

• ROGERS • DRUM OUTFITS

See the world's greatest array of smart drum sets on pages 6 to 21. Only Rogers have exclusive features such as Swiv-a-matic and Knobby Equipment; Perma-Tension Strainers; Stick Trays and many others.

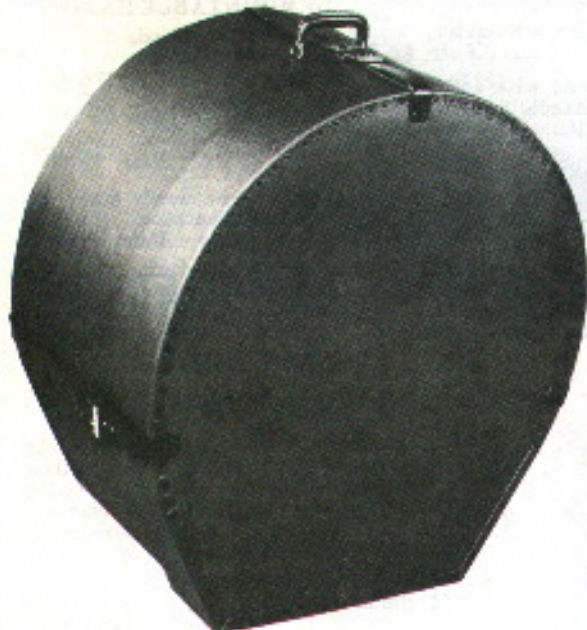

BONGO CASE

No. P12R—Each **\$15.00B**

Good quality fibre, to hold standard bongoes. Also serves as good utility case for beaters, traps, music.

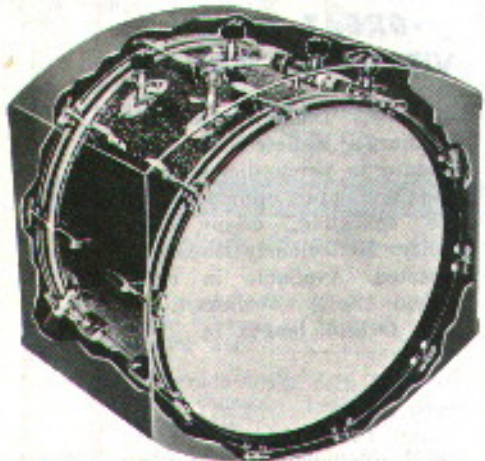

Interior view of Bass Drum and Shell Mounted Swiv-O-Matic Equipment in All-Purpose Case

• ROGERS • "ALL-PURPOSE" FIBRE BASS DRUM CASE

Exclusive Design to Accommodate Drums with Stay-On "Swiv-O-Matic" and "Knobby" Equipment.

No. 2014R—"All-Purpose" Case for 20" Drum with mounted equipment **\$35.00B**

No. 2214R—"All-Purpose" Case for 22" Drum with mounted equipment **\$37.50B**

Handy, practical, with 2 flat sides for more convenience and less bulk. Surprisingly easy to handle. Best case ever devised to hold drums with internal or shell mount attachments. Will take Swiv-O-Matic, with spurs. Also Knobby if spur-rods are removed.



Closed view of All-Purpose Case

"PROFESSIONAL" CASE

28" Long;
18½" Wide;
18½" Deep

No. 40—Snare Drum Case Each \$27.50B

No. 40
\$27.50B

Has adjustable partition and flap to hold any popular size snare drum; compartment for accessories. Lift-out tray, 22" x 16" x 2¼" holds additional traps and cymbals to 16". Wood frame cover, partial wood frame in metal edged body. Heavy hardware; Light weight yet extremely desirable.

"CARRY-ALL" CASE

For Snare and Traps

No. 20
\$25.75B
22" Long;
16" Wide;
18½" Deep

Ideal for drummers with a lot of traps. Has large 5½" compartment and section for any size snare drum. Removable tray, 22" x 9½" x 3¼", for additional traps. Also holds 15" cymbal.

No. 20—Snare Drum Case Each \$25.75B



DeLUXE CASES FOR KITS

No. 983—Plush Lined Each \$29.50
19½" Long; 18" Wide; 7½" Deep

DeLuxe leather-bound hard shell case, with plush lining. Has large 16" x 4¼" compartment for stand, sticks, pad, music, etc. This luggage model is fine quality throughout.



No. 990—Fabricoid Lined Each \$19.50

20" Long; 18½" Wide; 7½" Deep
Fabric covered veneer case lined with long-wearing material. Does NOT have bound edges. Large 16½" x 4¼" compartment holds basic accessories.



"STUDENT" FIBRE KIT CASES

No. F49R—Snare Drum Each \$7.50B
19½" Long; 16¼" Wide; 7½" Deep

budget price. Holds standard 14" snare drum. Has large 16¼" x 4¼" compartment for basic accessories.

No. F14R—Parade Drum Each \$7.50B
15½" Long; 15½" Wide; 18" Deep

A compact fibre case to fit standard 10" x 14" parade drum. Affords excellent protection at nominal cost.

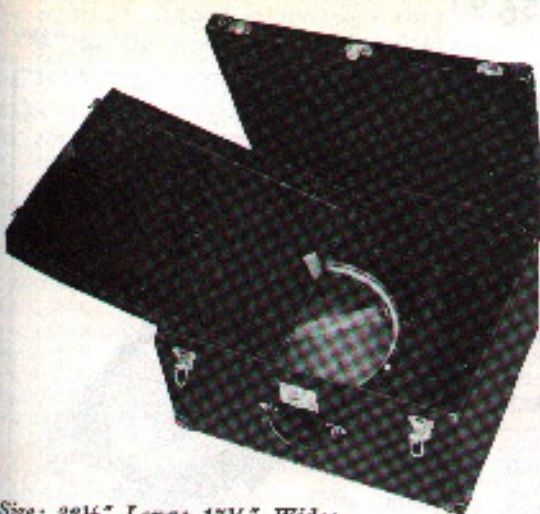

Size: 22½" Long; 17½" Wide;
10½" Deep

• ROGERS • "FIBER-KRAFT" SNARE DRUM CASE

No. 514R—Case for Snare Drum,
Accessories and
Cymbals \$15.00B

Terrific value. Quality, reinforced fiber case with features available only on more expensive models. Accommodates almost a complete set of accessories, holding any 14" drum, while lift-out tray measuring 22½" x 17" x 2¼" holds traps and cymbals up to 17" size. Has 2 accessory compartments, one 15" x 16¼" size for short traps; the other 22½" x 3¼" size for long stands, cymbal holders, sock pedals, etc. Literally eliminates need for snare drum cover, since it affords much better protection and holds practically all traps for only a little more investment.



• PORTABLE PORTER •

No. 6600—London Tan } \$6.95B
No. 6602—Blue } Each

New toggle HANDLE—with tensioning feature—automatically tightens strap to assure non-slip fit.

New type BUCKLE—releases easily with finger-tip action.

New RUBBER BUMPERS—protects luggage or cases.

Fits any size case, straps on like a skate. Rolls along easily, on silent rubber wheels. Saves time and unnecessary strain. Portable Porter does not have to be removed to open, close or store luggage or case.

• ROGERS • RAIN COVERS

No. 4123—Parade, for 14", 15"
or 16" Ea. \$3.50

No. 4109—Scotch, for 10" x 28" Ea. \$7.95

Transparent plastic, light, durable, compact, folds easily. Protects drum and head during rain or snow. Tone remains natural, even though heads are weather protected. Saves head, saves drum. Ideal for football season and holidays when marching drums are used. Covers full length of drum. One size fits 14", 15" and 16".



• ROGERS • POLISHING CLOTH

For All Wood Instruments
Large 15" x 17" Size

Washable, chemically treated cloth—SILICONE added. Puts brilliant gloss on instruments—wipes off finger marks, smudges or dust; will not injure finish. Supplied in re-usable plastic pouch.

No. 8626—Rogers Polishing
Cloth Doz. \$9.00



•ROGERS• DRUM COVERS

PROFESSIONAL QUALITY



Made of the highest grade, extra strong Covert (Mackintosh). Waterproofed, flannel lined. Finest workmanship. Reinforced seams. Designed to fit. Equipped with Zipper Fastener.

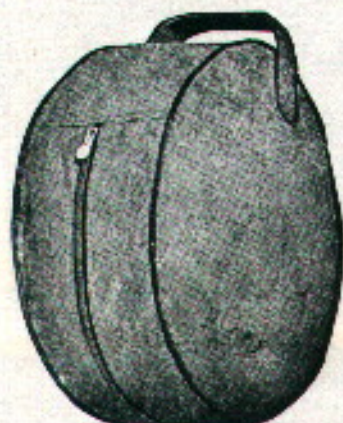

BASS AND SCOTCH with "Zipper"

No. 3141R—Shell size 12"x20"	\$12.00
No. 3142R—Shell size 14"x20"	
No. 3143R—Shell size 12"x22"	
No. 3144R—Shell size 14"x22"	\$12.00
No. 3145R—Shell size 8"x24"	\$12.75
No. 3146R—Shell size 12"x24"	
No. 3147R—Shell size 14"x24"	
No. 3148R—Shell size 8"x26"	\$13.50
No. 3149R—Shell size 10"x26"	
No. 3151R—Shell size 14"x26"	
No. 3152R—Shell size 8"x28"	\$14.40
No. 3153R—Shell size 10"x28"	
No. 3154R—Shell size 12"x28"	
No. 3155R—Shell size 14"x28"	
No. 3156R—Shell size 14"x30"	\$15.40
No. 3157R—Shell size 16"x32"	\$16.20
No. 3158R—Shell size 16"x34"	\$17.00

TOM TOM "Zipper" COVERS

No. 3121R—Shell size 7"x11"	\$7.00
No. 3122R—Shell size 8"x12"	7.20
No. 3123R—Shell size 9"x13"	7.20
No. 3124R—Shell size 12"x14"	7.80
No. 3125R—Shell size 14"x14"	8.20
No. 3126R—Shell size 14"x16"	8.30
No. 3127R—Shell size 16"x16"	8.40

SNARE DRUM "Zipper" COVERS

No. 3111R—Shell size 4"x13"	\$6.90
No. 3112R—Shell size 5"x14"	
No. 3113R—Shell size 5½"x14"	
No. 3114R—Shell size 6½"x14"	
No. 3115R—Shell size 8"x15"	

PARADE and TENOR with "Zipper"

No. 3161R—Shell size 10"x14"	7.50
No. 3162R—Shell size 10"x15"	7.80
No. 3163R—Shell size 12"x15"	8.00
No. 3164R—Shell size 12"x16"	8.10

HOW TO ORDER COVERS

Just Follow the Arrows!

The cut-away Snare drum shows proper method of determining shell size. Same applies to bass or parade drums and tom toms. Always give shell size only, disregarding over-all measurements. Please note that covers are made with allowance for lugs, rods and counter hoops.

Give Measurements "A" & "B"

BONGO OR UTILITY CASES

Made of simulated leather, valance stitched bindings. Flat, double-reinforced handle. Snap-type lock. Tough, washable, scuff-resistant. Light in weight. Tan Color only. All measurements are inside dimensions. Can be used for Bongos, Recording Tape, small Drum accessories and other small items. No. 918 takes 45 RPM records.

No. 612—Small size, 12½"x5½"x6½". Each \$6.00	No. 714—Medium size, 14½"x6½"x7½". Each \$9.00	No. 918—Large Size, 18"x7½"x9". Each \$12.00
---	--	--



•DRI-AIR• HEATER

Flexible, Neoprene-covered heater — 30" long, 1¼" wide, ¼" thick — generates efficient 20-watt heat. No. 9105—Dri-Air — Each \$9.95B

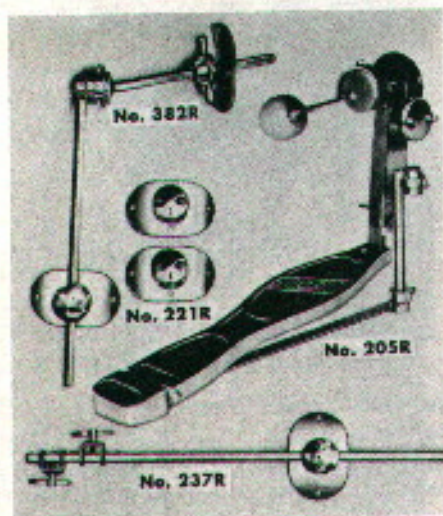

CONSTELLATION CONVERSION KIT

For converting CONSTELLATION OUTFIT to Combo or Cocktail Outfit. Complete with bolts, washers and nuts.

No. 4120R\$62.50

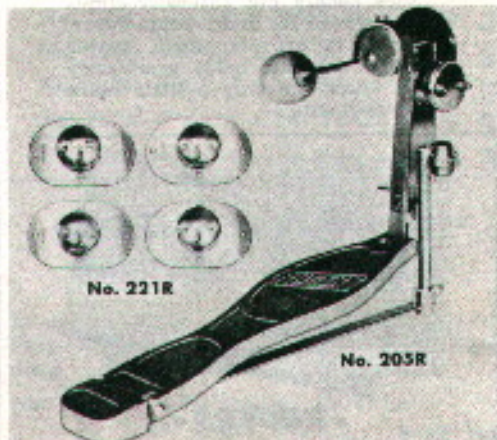

FESTIVAL CONVERSION KIT

For converting FESTIVAL OUTFIT to Combo or Cocktail Outfit. Complete with bolts, washers and nuts.

No. 4123R\$47.00

STARLITE CONVERSION KIT

For converting STARLITE OUTFIT to Combo or Cocktail Outfit. Complete with bolts, washers and nuts.

No. 4121R\$48.45

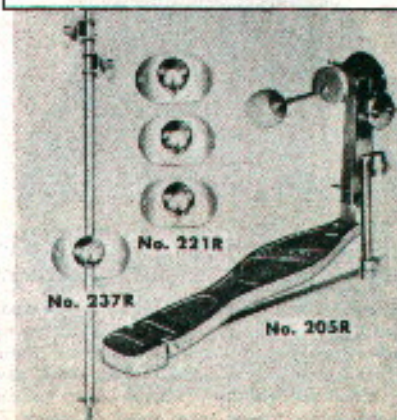



•ROGERS• DRUM HEADS

WORLD'S FINEST CALFSKIN



All Snare and Batter Mounted Heads for Orchestra, Tom Tom or Parade Drum; also Mounted Banjo Heads are Individually BOXED

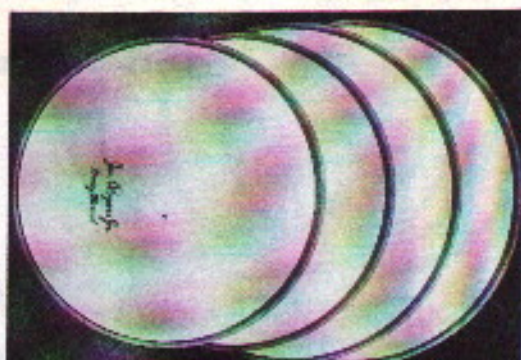

• ROGERS • DAISY BRAND •

SNARE — Transparent — Unmounted

No. 4623R—17" for 13" Shell Each \$ 8.75
 No. 4624R—18" for 14" Shell Each 7.25
 No. 4625R—19" for 15" Shell Each 7.75
 No. 4626R—20" for 16" Shell Each 8.25

SNARE — Mounted — Boxed

No. 4645R—Mounted for 13" Each \$ 8.25
 No. 4646R—Mounted for 14" Each 8.75
 No. 4647R—Mounted for 15" Each 9.25
 No. 4648R—Mounted for 16" Each 9.75

BATTER — Whitecalf — Unmounted

No. 4257R—16" for 12" Shell Each \$ 7.25
 No. 4657R—17" for 13" Shell Each 7.75
 No. 4658R—18" for 14" Shell Each 8.25
 No. 4659R—19" for 15" Shell Each 9.00
 No. 4660R—20" for 16" Shell Each 10.00

BATTER — Mounted — Boxed

No. 4259R—Mounted for 12" Each \$ 8.75
 No. 4653R—Mounted for 13" Each 9.25
 No. 4654R—Mounted for 14" Each 9.75
 No. 4655R—Mounted for 15" Each 10.50
 No. 4656R—Mounted for 16" Each 11.50

BASS DRUM — Whitecalf — Unmounted

No. 4690R—25" for 20" Bass Each \$19.50
 No. 4691R—27" for 22" Bass Each 21.50
 No. 4692R—29" for 24" Bass Each 23.50
 No. 4693R—31" for 26" Bass Each 25.00
 No. 4694R—33" for 28" Bass Each 27.50
 No. 4661R—35" for 30" Bass Each 30.00

BASS DRUM — Whitecalf — Mounted

No. 4695R—Mounted for 20" Each \$22.50
 No. 4696R—Mounted for 22" Each 24.50
 No. 4697R—Mounted for 24" Each 26.50
 No. 4698R—Mounted for 26" Each 28.00
 No. 4699R—Mounted for 28" Each 30.50
 No. 4662R—Mounted for 30" Each 33.00

• ROGERS • UNION BRAND •

SNARE — Transparent — Unmounted

No. 4667R—17" for 13" Shell Each \$ 7.25
 No. 4668R—18" for 14" Shell Each 7.75
 No. 4669R—19" for 15" Shell Each 8.25

SNARE — Mounted — Boxed

No. 4663R—Mounted for 13" Each \$ 8.75
 No. 4664R—Mounted for 14" Each 9.25
 No. 4665R—Mounted for 15" Each 9.75

BATTER — Whitecalf — Unmounted

No. 4612R—17" for 13" Shell Each \$10.00
 No. 4613R—18" for 14" Shell Each 10.75
 No. 4614R—19" for 15" Shell Each 11.50

BATTER — Mounted — Boxed

No. 4641R—Mounted for 13" Each \$11.50
 No. 4642R—Mounted for 14" Each 12.25
 No. 4643R—Mounted for 15" Each 13.00

• UNION BRAND • TYMPANI

Transparent — Unmounted

No. 4686R—30" for 24" Tympani Ea. \$32.50
 No. 4687R—31" for 25" Tympani Ea. 35.00
 No. 4688R—33" for 27" Tympani Ea. 37.50
 No. 4689R—34" for 28" Tympani Ea. 40.00
 No. 4611R—36" for 30" Tympani Ea. 43.50

• ROGERS • BANJO HEADS

MINSTREL BRAND — Unmounted

No. 7846—14" for 11" Banjo \$ 7.50
 No. 7847—15" for 12" Banjo 8.50

DAISY BRAND — Unmounted

No. 7858—14" for 11" Banjo \$10.00
 No. 7859—15" for 12" Banjo 11.00

UNION BRAND — Unmounted

No. 7861—14" for 11" Banjo \$12.50
 No. 7862—15" for 12" Banjo 13.50

THREE STAR BRAND — Unmounted

No. 7864—14" for 11" Banjo \$16.50
 No. 7865—15" for 12" Banjo 17.50



• ROGERS • BANJO HEADS

MINSTREL BRAND — Mounted — Boxed

No. G7848—For 11" Gibson } \$10.00
 No. V7848—For 11" Vega }
 No. K7848—For 11" Kay }
 No. S7848—Mounted on your Banjo \$12.50

DAISY BRAND — Mounted — Boxed

No. G7860—For 11" Gibson } Each
 No. V7860—For 11" Vega } \$12.50
 No. K7860—For 11" Kay }
 No. B7860—For 11" Bacon }
 No. S7860—Mounted on your Banjo \$15.00

UNION BRAND — Mounted — Boxed

No. G7863—For 11" Gibson } Each
 No. V7863—For 11" Vega } \$15.00
 No. B7863—For 11" Bacon }
 No. K7863—For 11" Kay }
 No. S7863—Mounted on your Banjo \$17.50

THREE STAR BRAND—Mounted—Boxed

No. G7866—For 11" Gibson } Each
 No. V7866—For 11" Vega } \$19.00
 No. B7866—For 11" Bacon }
 No. K7866—For 11" Kay }
 No. S7866—Mounted on your Banjo \$21.50

• ROGERS • PLASTEX BANJO HEADS

Mounted Plastic Heads

No. BG11R—For 11" Gibson } Each
 No. BV11R—For 11" Vega } \$8.00
 No. BP11R—Paramount 11" }

IMPORTANT

Heads should be mounted by competent service men. Not responsible for any damage caused by abuse, for unmounted heads soaked in water, or mounted heads forced on improper size shells.

• ROGERS • PLASTEX HEADS

A fine line of top quality Mounted Plastic Heads. Weather-proof, only one tensioning required. Excellent tonal qualities. Long-lasting, snappy response.

Mounted SNARE "ORCHESTRA"

No. S13R—for 13" Snare Each \$6.00
 No. S14R—for 14" Snare Each 6.50
 No. S15R—for 15" Snare Each 7.00

Mounted BATTER "ORCHESTRA"

No. B13R—for 13" Batter Each \$7.00
 No. B14R—for 14" Batter Each 7.50
 No. B15R—for 15" Batter Each 8.00

Mounted SNARE "PARADE"

Heavy Duty for Drum and Bugle Corps or Marching Band

No. PS13R—for 13" Snare Each \$6.00
 No. PS14R—for 14" Snare Each 6.50
 No. PS15R—for 15" Snare Each 7.00
 No. PS16R—for 16" Snare Each 7.50

Mounted BATTER "PARADE"

Heavy Duty for Drum and Bugle Corps or Marching Band

No. PB13R—for 13" Batter Each \$7.00
 No. PB14R—for 14" Batter Each 7.50
 No. PB15R—for 15" Batter Each 8.00
 No. PB16R—for 16" Batter Each 8.50

Mounted TOM TOM

No. TT12R—Mounted for 12" Each \$6.50
 No. TT13R—Mounted for 13" Each 7.00
 No. TT14R—Mounted for 14" Each 7.50
 No. TT15R—Mounted for 15" Each 8.00
 No. TT16R—Mounted for 16" Each 8.50

Mounted BASS DRUM

No. B20R—for 20" Bass Each \$17.00
 No. B22R—for 22" Bass Each 18.00
 No. B24R—for 24" Bass Each 19.00
 No. B26R—for 26" Bass Each 21.00
 No. B28R—for 28" Bass Each 22.00

• EVANS • PLASTIC HEADS

Mounted on Plastic Flesh Hoops

ORCHESTRA "SNARE" Medium Weight

No. S14E—for 14" Mounted Each \$7.20
 No. S15E—for 15" Mounted Each 7.80

ORCHESTRA "BATTER" Medium Weight

No. B14E—for 14" Mounted Each \$8.50
 No. B15E—for 15" Mounted Each 9.00

TOM TOM Medium Weight

No. TT12E—for 12" Mounted Each \$7.50
 No. TT13E—for 13" Mounted Each 8.00
 No. TT14E—for 14" Mounted Each 8.50

BASS DRUM Medium Weight

No. BD20E—for 20" Mounted Each \$18.00
 No. BD22E—for 22" Mounted Each 19.25
 No. BD24E—for 24" Mounted Each 20.50
 No. BD26E—for 26" Mounted Each 22.00
 No. BD28E—for 28" Mounted Each 24.00

PARADE "SNARE" Heavy Weight

No. PS14E—for 14" Mounted Each \$7.20
 No. PS15E—for 15" Mounted Each 7.80

PARADE "BATTER" Heavy Weight

No. PB14E—for 14" Mounted Each \$8.50
 No. PB15E—for 15" Mounted Each 9.00
 No. PB16E—for 16" Mounted Each 9.50

PLEASE NOTE: Heads immersed in water or forced on instrument will not be accepted for credit.

• WEATHER-KING • PLASTIC DRUM HEADS

- Not affected by any weather
- Even thickness
- Long life
- Crisp brush surface
- Aluminum mounting
- Superior sound qualities
- Three superior grades
- Excellent stick and brush response
- Tension to your personal taste
- Boxed

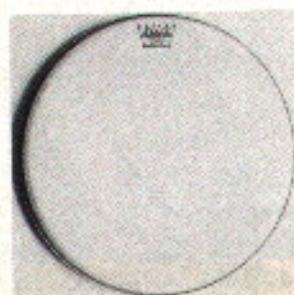

• DIPLOMAT •

The Weather-King DIPLOMAT is a light weight supersensitive drum head designed for the concert drummer who is called on to play delicate passages and where an extra sensitive tone is required.

DIPLOMAT "BATTER"

- No. DK-14—Size 14" -----Each \$7.50
- No. DK-15—Size 15" -----Each 8.00

DIPLOMAT "TOM-TOM"

- No. DT12—Size 12" -----Each \$6.50
- No. DT13—Size 13" -----Each 7.00
- No. DT14—Size 14" -----Each 7.50
- No. DT15—Size 15" -----Each 8.00
- No. DT16—Size 16" -----Each 8.50
- No. DT18—Size 18" -----Each 9.75



• AMBASSADOR •

The Weather-King AMBASSADOR was created to meet the requirements of the professional dance band, combo, or orchestra drummer. It has been found satisfactory at the junior high and high school concert band levels. Its tonal qualities and all around performance make it the ideal general purpose drum head.

AMBASSADOR "SNARE"

- No. SA13—Size 13" -----Each \$6.00
- No. SA14—Size 14" -----Each 6.50
- No. SA15—Size 15" -----Each 7.00
- No. SA16—Size 16" -----Each 7.50

AMBASSADOR "BATTER"

- No. AK13—Size 13" -----Each \$7.00
- No. AK14—Size 14" -----Each 7.50
- No. AK15—Size 15" -----Each 8.00
- No. AK16—Size 16" -----Each 8.50

AMBASSADOR "TOM-TOM"

- No. AT12—Size 12" -----Each \$6.50
- No. AT13—Size 13" -----Each 7.00
- No. AT14—Size 14" -----Each 7.50
- No. AT15—Size 15" -----Each 8.00
- No. AT16—Size 16" -----Each 8.50
- No. AT18—Size 18" -----Each 9.75

AMBASSADOR "BASS DRUM"

- No. WK20—Size 20" -----Each \$17.00
- No. WK22—Size 22" -----Each 18.00
- No. WK24—Size 24" -----Each 19.00
- No. WK26—Size 26" -----Each 21.00
- No. WK28—Size 28" -----Each 22.00
- No. WK30—Size 30" -----Each 23.00
- No. WK32—Size 32" -----Each 25.00



• EMPEROR •

The Weather-King EMPEROR is a heavy duty drum head designed to absorb considerable impact over long periods of time with little or no sacrifice in tonal excellence. Highly recommended for drum and bugle corps and all marching bands.

EMPEROR "SNARE"

- No. ES13—Size 13" -----Each \$6.00
- No. ES14—Size 14" -----Each 6.50
- No. ES15—Size 15" -----Each 7.00
- No. ES16—Size 16" -----Each 7.50

EMPEROR "BATTER"

- No. EB13—Size 13" -----Each \$7.00
- No. EB14—Size 14" -----Each 7.50
- No. EB15—Size 15" -----Each 8.00
- No. EB16—Size 16" -----Each 8.50
- No. EB17—Size 17" -----Each 9.25
- No. EB18—Size 18" -----Each 9.75



• WEATHER-KING • TYMPANI

Same general specifications as above. Tympani sizes vary — therefore specify exact inside diameter of old hoop when ordering. Sizes other than standard 25" or 28" will be supplied special on a positive, non-returnable basis only. Need two weeks to deliver special sizes. For purity of sound and trouble free performance in all types of climate, select Weather-King Tympani heads as have Charles White, L. A. Philharmonic and Saul Goodman, N.Y. Philharmonic. Please note—when ordering Tympani heads, specify brand of Tympani to assure proper fitting.

Mounted On Metal Hoops

- No. TK25—25" Standard -----Each \$21.00
- No. TK28—28" Standard -----Each 24.00
- No. WL28—28" WFL Tympani Each 24.00



It's little wonder that drummers the world over mention Weather-King drum heads when speaking of a good drum sound and a good drum feel. Only the Weather-King drum heads give you both sound and feel on whatever make drum you play. Our carefully applied surface is capable of providing you with both. Weather does not affect the drum heads, so you can depend on a discriminating performance.



• WEATHER-KING • BANJO

Banjo authorities use and recommend Weather-King banjo heads for the best crisp sound. When ordering, give the exact banjo shell measurement (outside diameter). SPECIFY MAKE OF BANJO.

Mounted On Metal Hoops

- No. WKB11—For 11" Diameter -----Each \$8.00
- WKB11A—For 11-1/16" Diameter ----- 8.00
- WKB11B—For 11-1/8" Diameter ----- 8.00
- WKB11P—For 11-3/16" Diameter ----- 8.00
- OTHER SIZES (To Special Order)----- 10.00



• BUCKEYE • BRAND

SNARE SIDE — TRANSPARENT

Transparent genuine calf-skin; good quality, even thickness. Unmounted, for SNARE side.

No.	Each
4500—17" transparent for 18" drum	\$5.05
4501—18" transparent for 14" drum	5.75
4502—19" transparent for 15" drum	6.10

BATTER SIDE—WHITE CALF-SKIN

Good quality white, genuine calf-skin; clean and even. Unmounted, for BATTER side.

No.	Each
4506—17" whitecalf for 13" drum	\$4.80
4507—18" whitecalf for 14" drum	5.40
4508—19" whitecalf for 15" drum	5.70

BASS DRUM—WHITE CALF-SKIN

Good quality white, genuine calf-skin, smooth, hard and even. Unmounted.

No.	Each
4512—28" whitecalf for 24" drum	\$14.90
4513—30" whitecalf for 26" drum	16.20
4514—32" whitecalf for 28" drum	17.40

• BUCKEYE • BRAND

Mounted on Wood Hoops

No.	Each
4550—for 18" snare side	\$5.85
4551—for 14" snare side	6.30
4552—for 15" snare side	6.85
4554—for 13" batter side	5.50
4555—for 14" batter side	6.20
4556—for 15" batter side	6.40



DRUM HEAD TUCKER

No. 586—"Perfection" Tucking Tool. Each \$.90



• ROGERS • WHEEL TUCKER

No. 4599—"ROGERS" Tucker, novel and practical, with wheel. Each \$3.00

• ROGERS •

METAL COUNTERHOOPS

Specify Size and Type of Drum

No. 4230R—Batter side, "L" shaped For parade, orchestra, or tom-toms. Chrome-plated	Each \$5.50
No. 4231R—Snare side, "L" shaped For snare drums, or tom-toms. Chrome-plated	Each 6.00
No. 4295R — Batter side, Triple Flange. For drums or tom-toms. DeLuxe Chrome	Each 9.50
No. 4296R — Snare side, Triple Flange. For parade or orchestra drums. DeLuxe Chrome	Each 10.00

DRUM HEADS



• KLEARTONE • PROFESSIONAL

SNARE SIDE—TRANSPARENT

Clear, natural transparent calf-skin with hard finish, assuring responsive action. Unmounted, for SNARE side.

No.	Each
4519—17" transparent for 13" drum	\$5.25
4520—18" transparent for 14" drum	6.10
4521—19" transparent for 15" drum	6.50
4522—20" transparent for 16" drum	7.10
4523—21" transparent for 17" drum	7.50
4524—22" transparent for 18" drum	8.00

BATTER WHITE-CALF HEADS

Selected, choice quality white calf-skin, carefully inspected for evenness, texture, and appearance. Unmounted, for BATTER side of drum, or for Tom Tom.

No.	Each
4060—16" whitecalf for 12" shell	\$4.65
4529—17" whitecalf for 13" shell	5.30
4530—18" whitecalf for 14" shell	6.00
4531—19" whitecalf for 15" shell	6.30
4532—20" whitecalf for 16" shell	6.70
4533—21" whitecalf for 17" shell	7.00
4534—22" whitecalf for 18" shell	7.40

WHITE-CALF BASS DRUM HEADS

Choice, selected white calf-skin. Inspected with extra care for evenness, texture, and appearance. Unmounted.

No.	Each
4225—24" whitecalf for 20" drum	\$12.50
4226—26" whitecalf for 22" drum	15.25
4535—28" whitecalf for 24" drum	16.50
4536—30" whitecalf for 26" drum	18.00
4537—32" whitecalf for 28" drum	19.40
4538—34" whitecalf for 30" drum	20.75
4539—36" whitecalf for 32" drum	22.50
4540—38" whitecalf for 34" drum	24.00
4541—40" whitecalf for 36" drum	26.50

• KLEARTONE • PROFESSIONAL

Mounted on Wood Hoops

No.	Each
4560—for 14" snare side	\$ 7.00
4561—for 15" snare side	7.40
4562—for 16" snare side	7.85
4068—for 12" batter, whitecalf	5.35
4069—for 13" batter, whitecalf	6.10
4563—for 14" batter, whitecalf	6.70
4564—for 15" batter, whitecalf	7.00
4565—for 16" batter, whitecalf	7.40
4227—for 20" bass drum	15.25
4228—for 22" bass drum	18.00
4229—for 24" bass drum	19.50
4566—for 26" bass drum	20.75
4567—for 28" bass drum	22.15

"IMPORTANT"

We recommend that heads be mounted by competent service men. Not responsible for unmounted heads soaked in water, mounted heads forced on improper size shells, or damage caused by abuse. Prices subject to change with market.

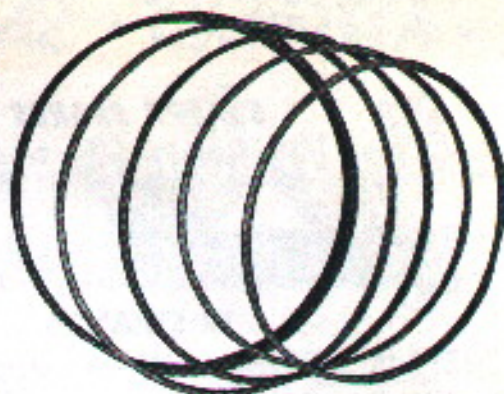

• ROGERS • FLESH HOOPS

SNARE and PARADE FLESH HOOPS

No.	Each
4572—For 18" snare	} \$.75
4573—For 13" batter	
4574—For 14" snare	
4575—For 14" batter	
4576—For 15" snare	
4577—For 15" batter	

BASS DRUM FLESH HOOPS

No.	Each
4878—For 20" Drum	} \$1.80
4879—For 22" drum	
4580—For 24" drum	
4581—For 26" drum	
4582—For 28" drum	



• ROGERS • COUNTER HOOPS

Maple, Lacquered

SNARE and PARADE COUNTER HOOPS

No.	Each
4584R—For 13" snare	} \$3.00
4585R—For 13" batter	
4586R—For 14" snare	
4587R—For 14" batter	
4588R—For 15" snare	
4589R—For 15" batter	

BASS DRUM COUNTER HOOPS

No.	Each
4877R—For 20" drum	} \$6.00
4880R—For 22" drum	
4592R—For 24" drum	
4593R—For 26" drum	
4594R—For 28" drum	

• ROGERS • PRESS & RETAINER

Holds one dozen mounted heads Keeps heads on hoops straight and round without danger of warping.

No. 4570—For 14" heads	} \$9.00
No. 4571—For 15" heads	

BONGO HEADS

No. BS68—Goatskin, unmounted	Ea. \$1.80
No. MTS68—Mounted, small or large size (specify). Goatskin	Ea. 3.00

CONGA HEADS

No. GS18—Unmounted 18" Goatskin	Each \$ 3.75
No. MS18—Unmounted 18" Muleskin	Each 9.75
No. MS20—Mounted Muleskin for Tunable Conga	Each 13.50

(Specify head size)

ROGERS • SNARES

SNAPPY SNARES

Made of special quality coiled steel wire. Trenched butt plates provide for better response. Chrome-plated. Individually packaged.



12 STRANDS

No. 4471—For 13" Drum }
 No. 4468—For 14" Drum } Each \$3.00
 No. 4456—For 15" Drum }



16 STRANDS

No. 4717—For 14" Drum }
 No. 4718—For 15" Drum } Each \$3.30



20 STRANDS

No. 4457—For 14" Drum }
 No. 4458—For 15" Drum } Each \$3.50
 No. 4465—For 16" Drum }



WIRE-WOUND SNARES WITH BUTTS

No. 4466—Wire wound, orchestra size, 15 gauge. Each }
 No. 4467—Wire wound, field drum size, 13 gauge. Each } \$1.50

GUT SNARES WITH BUTTS

No. 4118—12 Strands, light weight Each \$4.00
 No. 4119—12 Strands, heavy weight Each 4.50
 No. 4709—Fiber Butts Each .10



ROGERS • THUMB-SCREWS

No. 4232—Thumb-screw for all Rogers clamps. Threaded $\frac{1}{2}$ " Chrome Plated. Each \$.35
 No. 4233—Same as above, threaded $\frac{3}{8}$ " Each .35

ROGERS • SLING HOLDERS

No. 4454—Rod model. Mounted or fitted on claw rod, has hole for sling hook. Chrome. Dozen \$3.00



No. 4454

No. 4455—Hoop model. Plate and hoop are screwed to counter hoop of parade drum. Chrome-plated. Dozen \$6.00



No. 4455



SLING HARDWARE Nickel-Plated

No. 4090

No. 4093

No. 4094

Each
 No. 4090 Swivel Snap Eye Hook \$1.00
 No. 4091 Wire Buckle60
 No. 4092 Adjusting Buckle90

Each
 No. 4093 Swivel Snap Hook \$.90
 No. 4094 Adjustment Bracket50

ROGERS • STRAINERS

SWIV-O-MATIC® PERMA-TENSION

Another Rogers
Engineering Triumph!

Most practical and most efficient strainer ever designed . . . The special tempered roller mechanism, combined with the precision slide construction, assures smooth, perfect action with a minimum of effort. The spring-loaded cartridge bearing, carrying the tension screw, eliminates constant readjusting of snares by holding tension screw in fixed position, whether snares are on or off . . .

The angular, cut-away base allows strainer to pull snare cord at the proper angle for precise action and alignment . . . the SWIV-O-MATIC Perma-Tension snare strainer renders positive, fool-proof performance. Fits practically all makes and models of Orchestra and Parade Drums.

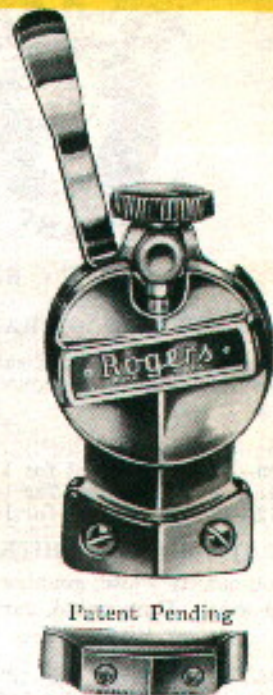

Patent Pending

Butt or back plate

No. 390R—SWIV-O-MATIC Perma-Tension Snare Strainer, complete with specially designed butt assembly. \$13.50

POPULAR PRICED STRAINERS

← "COMPACT" THROW-OFF STRAINER

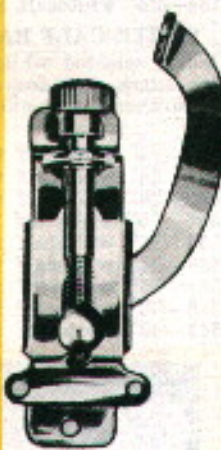

No. 4476

Small, compact but highly efficient. Works smoothly and easily. Ideal for orchestra drums. Each

No. 4476—Chrome, (without back-plate) \$4.50

"UNIVERSAL" → THROW-OFF STRAINER



No. 4472

The standard, reliable throw-off strainer. Operates with ease and precision. Used on both orchestra and parade drums. Each

No. 4472—Chrome, (without back-plate) \$5.50

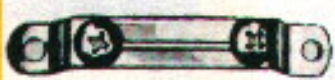

No. 4482—Back-plate for above, Chrome Each \$.75



No. 4475—Back-plate for above, Chrome Each \$1.00

FIELD DRUM OR MILITARY STRAINER

Carefully engineered to give smooth, easy, positive action. Has holes for wire-wound or gut snares. No. 4474—Chrome-plated, (without back-plate) Each \$4.50



No. 4474



No. 4475—Back-plate for 4474 Chrome-plated. Each \$1.00

TENSION SCREW

With knob, for field drum strainer. Permits adjustment of snare tension.

No. 3468—Chrome-plated Each .75 No. 3468



DRUM RODS—HOOKS—LUGS—HOLDERS



• ROGERS • DRUM KEYS

No. 4409—Chrome-plated per dozen **\$4.80**

Full grossper dozen **\$4.82**

Made of hard tool steel, specially designed to fit triple flange hoops as well as "L" hoops. Will fit all SWIV-O-MATIC and KNOBBY holders, spurs, tilters, etc.

• ROGERS • KEY HOLDERS

No. 4414—Chrome Finish, with screws and washers.Dozen **\$6.00**



• ROGERS •

KEY TENSION RODS

Key Tension Rods, square head, triple-plated. Specify size. (Length from under collar to threaded end)



No. 4930—1½" } **\$4.80**
 No. 4931—2" }
 No. 4932—2½" } Doz.
 No. 4933—3" } **\$6.00**
 No. 4934—3½" }
 No. 4935—4" } Doz.

No. 4936—4½" } **\$6.00**
 No. 4937—5" }
 No. 4929—5½" } Doz.
 No. 4938—6" }
 No. 4939—8" } **\$7.20**
 No. 4940—10" }
 No. 4942—13" } Doz.

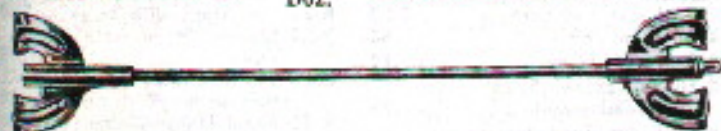

• ROGERS • PARADE or SCOTCH DRUM RODS

Professional Quality—Chrome Plated

Square head, key tension, triple-plated, with 2 Scotch claw hooks.

No. 4493—For 8 inch drum, Chrome-plated } **Each \$2.70**
 No. 4480—For 10 inch drum, Chrome-plated }
 No. 4481—For 12 inch drum, Chrome-plated }

• ROGERS • "T" HANDLE RODS ONLY—With Collar

For Double Claw Hooks

No. 4943—Size 3¼ inch, Chrome-plated Each \$.90
 No. 4944—Size 7½ inch, Chrome-plated Each 1.00
 No. 4911—Size 13¼ inch, Chrome-plated Each 1.10
 No. 4912—Size 15¼ inch, Chrome-plated Each 1.20



With 2 Double Claw Hooks and Collar Under "T" Handle

No. 4297—For 12 inch drum, Chrome-plated Each } **\$3.15**
 No. 4298—For 14 inch drum, Chrome-plated Each }

HOW TO ORDER DRUM RODS

Give Shell Measurements Only, Without Counter Hoops.

• ROGERS •

DRUM CENTER SUPPORTS

No. 4477—For use with drum rods, complete with screws, washers, etc. Chrome-plated. For snare drum. Each \$ **.50**

No. 4470—Same as above. For bass drum Each **.50**

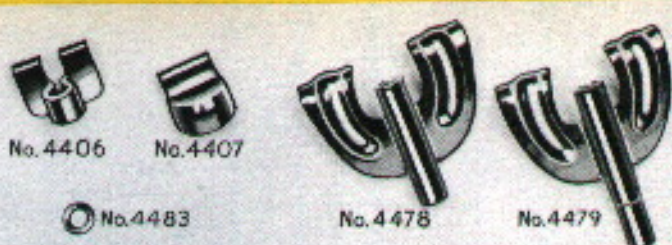
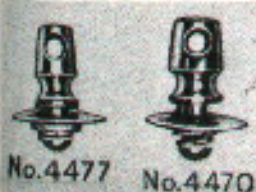

• ROGERS • DRUM HOOKS—CHROME PLATED

No. 4406 —Collar hooks, double claw Each \$.50
 No. 4406P—Collar hooks, double claw, threaded insert Each .70
 No. 4407 —Collar hooks, single claw Each .40
 No. 4478 —Scotch type, double claw, plain Dozen 9.60
 No. 4479 —Scotch type, double claw, threaded Dozen 10.80
 No. 4483 —Washers for drum rods Dozen .35

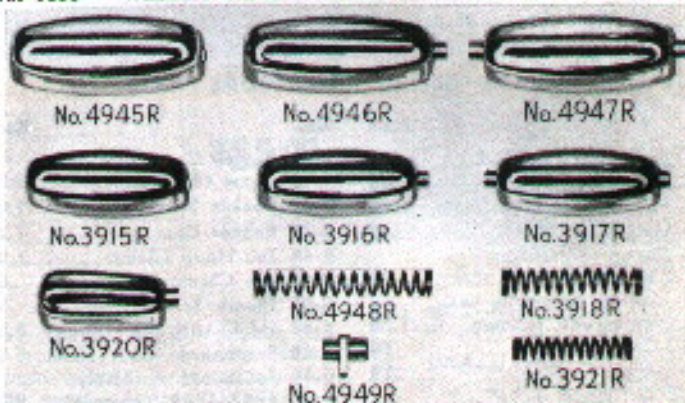

• ROGERS • LUGS - LUG NUTS - LUG SPRINGS

Drawn Brass—Mirror Finish Chrome-Plated

PLEASE SPECIFY for which type of drum desired

No. 4945R—Lug, 2½" long, 2 holes for single tension rod to go through lugs (without lug nut or springs). Mounting holes spaced 2¼" apart Each \$1.20
 No. 4946R—Lug, 2½" long, with 1 self-aligning nut and spring. For separate tension. Mounting holes spaced 2¼" apart Each \$1.35
 No. 4948R—Lug Spring, for above Each .06
 No. 4949R—Lug Nut, for above Each .25
 No. 4947R—Lug, 2½" long, with 2 self-aligning nuts and springs. For separate tension. Mounting holes spaced 2¼" apart Each \$1.35
 No. 4948R—Lug Spring, for above Each .06
 No. 4949R—Lug Nut, for above Each .25
 No. 3915R—Lug, 2¼" long, 2 holes for single tension (without lug nut or spring). Mounting holes 1¼" apart Each \$1.20
 No. 3916R—Lug, 2¼" long, with 1 self-aligning lug nut and spring. For separate tension. Mounting holes spaced 1¼" apart Each \$1.35
 No. 3918R—Lug Spring, for above Each .06
 No. 4949R—Lug Nut, for above Each .25
 No. 3917R—Lug, 2¼" long, with 2 self-aligning lug nuts and springs. For separate tension. Mounting holes spaced 1¼" apart Each \$1.35
 No. 3918R—Lug Spring, for above Each .06
 No. 4949R—Lug Nut, for above Each .25
 No. 3920R—Lug, 1¼" long, with 1 self-aligning lug nut and spring. For separate tension. Mounting holes spaced 1¼" apart Each \$1.35
 No. 3921R—Lug Spring, for above Each .06
 No. 4949R—Lug Nut, for above Each .25

PEDAL PARTS

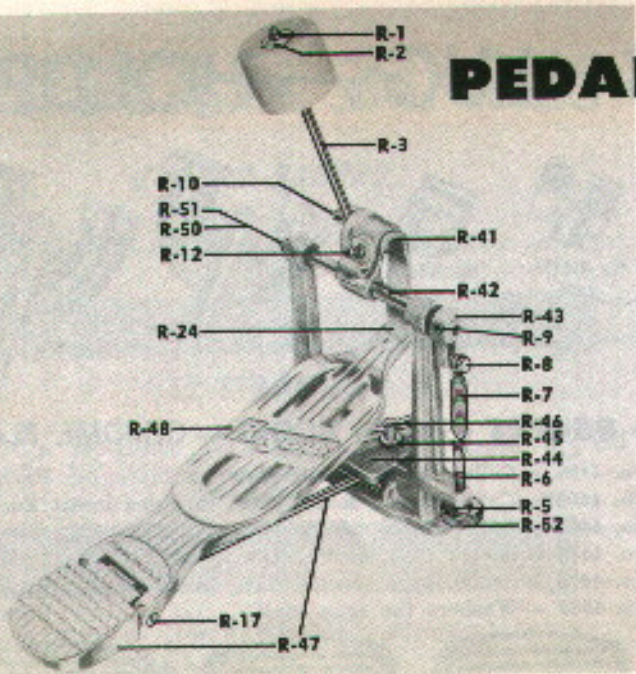

No. 398 "Rocket" FOOT PEDAL PARTS

No.	Each	No.	Each
R-1 Pedal Ball Hex Nut	.15	R-41 Beater Cam, with set screw (R10)	3.50
R-2 Pedal Ball Washer	.05	R-42 Rocker Shaft Rod	1.00
R-3 Pedal Beater, complete	2.50	R-43 Rocker Cam	1.25
R-5 Lock Washer	.05	R-44 Toe Hoop Clamp	1.00
R-6 Spring Adjustment Screw	.35	R-45 Toe Clamp Washer	.05
R-7 Spring Assembly, with hooks and bushing	1.20	R-46 Thumb Screw	.50
R-8 Cam Bolt	.50	R-47 Heel, with "T" Rod	3.50
R-9 Allen Screw	.15	R-48 Footboard	5.50
R-10 Set Screw, 5/16" thread length	.15	R-49 Footboard Assembly, (R47—R48) complete	9.00
R-12 Pull Set Screw, 3/8" thread length	.20	R-50 Rocker Shaft Locking Nut	.15
R-17 Heel Bearing Screw	.50	R-51 Rocker Shaft Locking Screw	.50
R-24 Leather Strap, with screw	.75	R-52 Tension Spring Adjusting Nut	.40

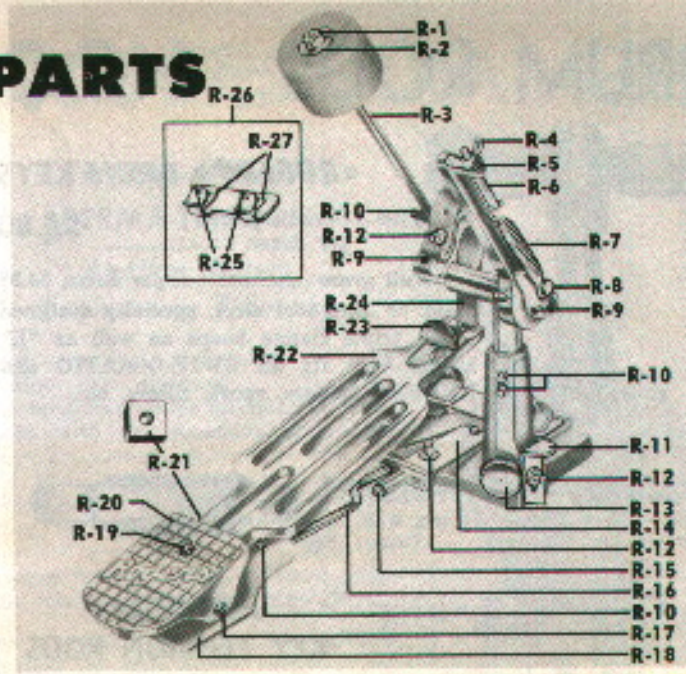

No. 395R "Swiv-o-matic" FOOT PEDAL PARTS

No.	Each	No.	Each
R-1 Pedal Ball Hex Nut	.15	R-16 "T" Rod	2.00
R-2 Pedal Ball Washer	.05	R-17 Heel Bearing Screw	.50
R-3 Pedal Beater, complete	2.50	R-18 Heel Base	1.50
R-4 Wing Nut	.15	R-19 Heel Pull Set Screw	.20
R-5 Lock Washer	.05	R-20 Heel	2.00
R-6 Spring Adjustment Screw	.35	R-21 Threaded Heel Plate, (underneath heel)	.50
R-7 Spring Assembly, with hooks and bushing	1.20	R-22 Footboard	6.00
R-8 Cam Bolt	.50	R-23 Toe Stop, with screw	1.00
R-9 Allen Screw	.15	R-24 Leather Strap, with screw	.75
R-10 Set Screw, 5/16" thread length	.15	R-25 Set Screw, 7/16" thread length	.20
R-11 Pedal Spur (specify right or left)	.75	R-26 Pedal Hoop Clamp complete	6.00
R-12 Pull Set Screw, 3/8" thread length	.20	R-27 Clamp Pressure Plate, (Specify right or left)	.50
R-13 Locking Screw	1.00	R-28 Footboard Assembly, complete (R10—R16—R17(2)—R-18—R-19—R-20—R-21—R-22—R-23)	12.50
R-14 Swivel Unit	2.00		
R-15 Spring Pin Assembly	.75		

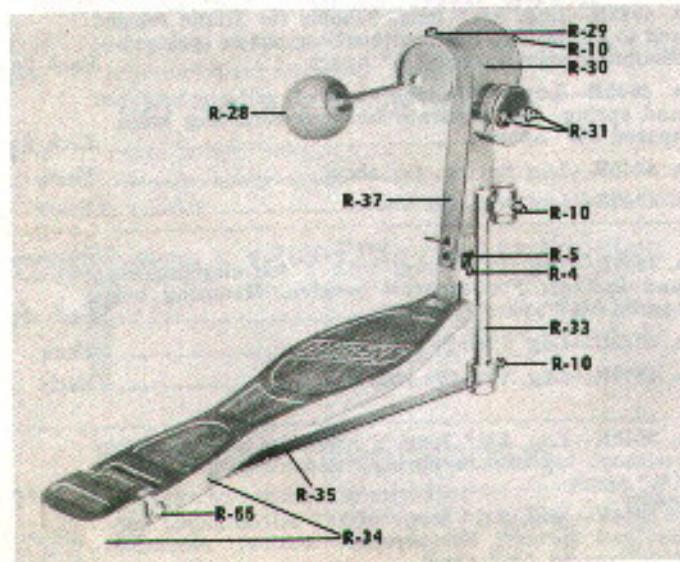

No. 205R "Cocktail" FOOT PEDAL PARTS

No.	Each	No.	Each
R-4 Wing Nut	.15	R-31 Pull Set Screw, 5/8" thread length	.25
R-5 Lock Washer	.05	R-32 Spring Adjustment Screw (not shown)	.35
R-6 Spring Adjustment Screw	.35	R-33 Pedal Adapter, complete with set screw (R10)	2.00
R-7 Spring Assembly, with hooks and bushing (not shown)	1.20	R-34 Footboard and Heel	4.25
R-10 Set Screw, 5/16" thread length	.15	R-35 Metal Footboard Strap, with collar	1.50
R-28 Wood Pedal Beater	2.50	R-36 Footboard Assembly, complete (R34—R35—R55)	5.75
R-29 Slotted Set Screw	.25	R-37 Leather Strap, with metal hinge	1.00
R-30 Pedal Housing Assembly	10.50	R-55 Rivet	.10

No. 396R "Swiv-o-matic" FOOT PEDAL PARTS

Same as on No. 395R, except Footboard, Heel & "T" Rod

No.	Each
R-38 Footboard	6.00
R-39 Heel, with "T" Rod	3.50
R-40 Footboard Assembly, (R38—R39—R17(2) complete	10.00

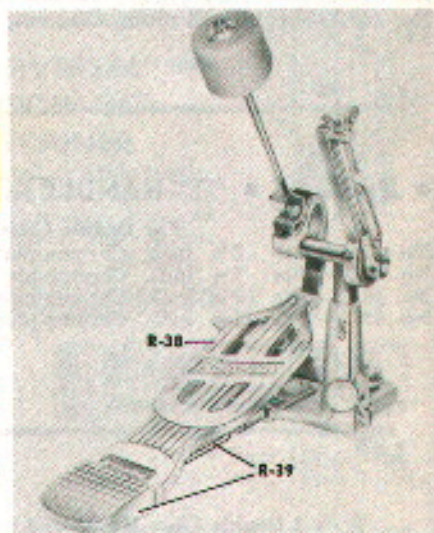

No. 399 "Jet" FOOT PEDAL PARTS

Same as No. 398, except Footboard, Heel & "T" Rod.

No.	Each
R-53 Footboard	3.00
R-54 Heel & "T" Rod	2.50
R-55 Rivet	.10
R-56 Footboard Assy. (R53—R54—R55) complete	5.50

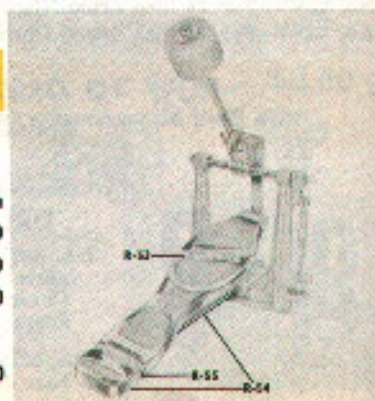

POPULAR BONGOS



PEARL TOY BONGOS

No. 005MP—Size 5½" x 4½"
Height 5" —Per Set \$4.75

Just like professional bongos. Made of substantial spiral tubing covered with a Mother-Of-Pearl pearlette. Heads are real rawhide skin. Made in U.S.A. Individually boxed.



BASS BONGOS

No. 4999—Tall, 11" high.
Extra deep tone, super value —Set \$16.50

Desirable to round out rhythm section. Made in Mexico, of two-toned natural colored wood. Goat skin heads. 6½" x 7½".



JUNIOR BONGOS

No. 4995—Popular size Bongos, ideal for all occasions —Set \$7.25

A compact, sturdily constructed Mexican importation. Two-tone natural colored wood. Goat skin heads. 5" x 5½". Height 6½".



BONGO CASES

Made of simulated leather, with valance stitched binding. Flat double re-inforced handle. Snap type lock. Tough, scuff-resistant, washable. Tan color. Sizes given are inside measurements.

No.	Each
612—12½" x 5½" x 6½"	\$6.00
714—14½" x 6½" x 7½"	9.00
918—18" x 7½" x 9"	12.00



•ROGERS• HOLIDAY PEARL BONGOS

Lustrous Pearl — Tunable — Chrome Fittings

No.	Color	Per Set
No. 4050	Marine White Pearl	\$55.00
No. 4051	Black Diamond Pearl	
No. 4052	Gold Sparkle Pearl	
No. 4053	Mardi Gras Pearl	
No. 4054	Blue Sparkle Pearl	
No. 4056	Jet Black Pearl	
No. 4057	Red Sparkle Pearl	
No. 4058	Silver Sparkle Pearl	
No. 4059	Green Sparkle Pearl	
No. 4061	Steel Gray Ripple Pearl	
No. 4064	Sky Blue Ripple Pearl	
No. 4067	Wine Red Ripple Pearl	
No. 4066	Black Onyx Pearl	
No. 4068	Blue Onyx Pearl	

A worthy companion to the Holiday line of Rogers drums, in matching pearl colors. Regulation tunable models, head sizes 8" and 6", height 5½". Sturdy, light-weight, with connector fitted to take bongo holder. Also fits most standard floor cymbal stands. Double-flanged hoops, quality heads, self-aligning tension lugs. All hardware in gleaming chrome.



STANDARD BONGOS

No. 4996—Reg. Bongos curved sides —Set \$9.90

Made in Mexico of fine two-tone natural colored wood. Goat skin heads, size 6½" x 7½". Height 6½".

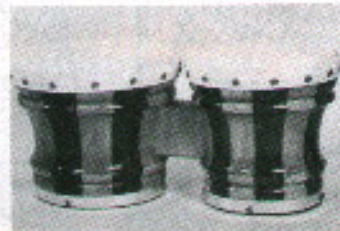

DeLUXE BONGOS

No. 4997—Large DeLuxe Bongos. Made in Mexico —Set \$12.50

Best non-tunable model, two-tone natural wood finish, goat skin heads. Height 6½", head sizes 7½" x 8½".



POPULAR TUNABLE BONGOS

Popular tunable bongos, sparkle pearl finish, chrome fittings. Three easy tuning thumb screws. Heads 6½" and 7½", height 6½".

No. F4001	Red Sparkle Pearl	\$23.50
No. F4002	Blue Sparkle Pearl	
No. F4004	Silver Sparkle Pearl	
No. F4005	Gold Sparkle Pearl	
No. F4006	White Marine Pearl	
No. F4007	Black Marine Pearl	



MINIATURE BONGOS

No. 4908—Size 4½" and 3½". Made in Mexico —Set \$4.50

Ideal for rhythm in home or school. Made in perfect detail as the regulation model. Two-tone natural wood, reinforced skin heads.



HAND BONGOS

No. 4987—Medium 6" x 6" —Each \$4.50

No. 4988—Large 6½" x 8" —Each \$6.75

Single hand bongos, made of two-tone natural color wood. Goat skin heads, plastic strap handles. Mexican's best.



TUNABLE BONGOS

No. 4994—Mexican Bongos Chrome-plated hardware —Set \$32.00

Hand made, two-tone natural wood, good chrome hardware, self-aligning lugs, quality calf-skin heads. Perfect Bongo tone. Size 6½" and 7½".

BONGO CASE

No. F12R—Fibre —\$15.00 B

•ROGERS•

BONGO HOLDERS

No. 4780
Hoop Mount
Chrome Plated—
Each \$6.00

Supplied with bracket for attaching to Bongos with wood connectors. Clamps on bass drum hoop and adjustable for height.



CONGA DRUMS

Carrying straps and handles are attached to all drums.

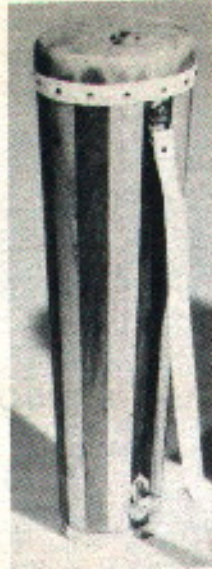

No. 112—SMALL CONE SHAPED CONGA Each \$18.00
Two-tone natural finish—22" high — 8" heavy Goat head.



No. 131 — SMALL ROUND SHAPED CONGA Each \$22.50
Brilliant tri-color design — 25" high — 8" Mule head.



No. 111 — SMALL ROUND SHAPED CONGA Each \$22.50
Two-tone natural finish — 24" high — 8" Mule head.



No. 4894 — LARGE ROUND BARREL SHAPED CONGA
Each \$45.00
Brilliant tri-color design — Reinforced with metal bands — 30" high — 11 1/2" Mule head.

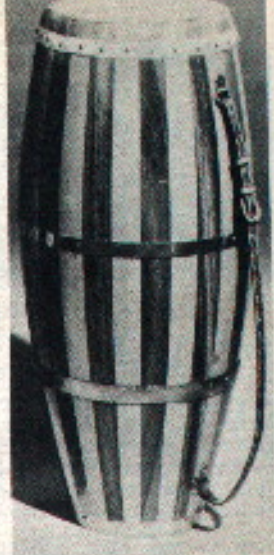

No. 4903 — LARGE BARREL SHAPED CONGA Each \$45.00
Two-tone natural finish — Reinforced with metal bands — 30" high — 11 1/2" Mule head.

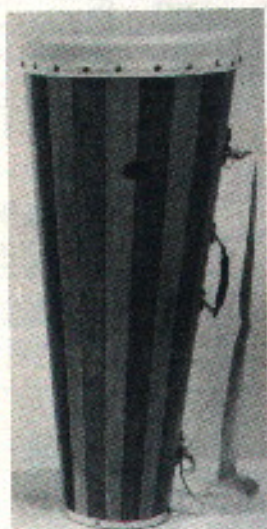

No. 4891 — LARGE CONE SHAPED CONGA Each \$27.00
Two-tone natural finish — 28" high — 12" heavy Goat head.

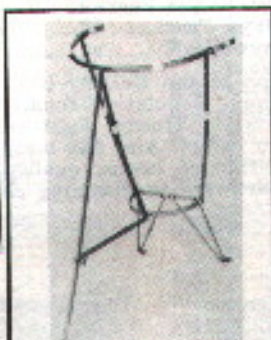

No. 163 — CONGA STAND DELUXE
Each \$12.00
Strong metal — Adjustable for sitting or standing position — Fits large conga drum.

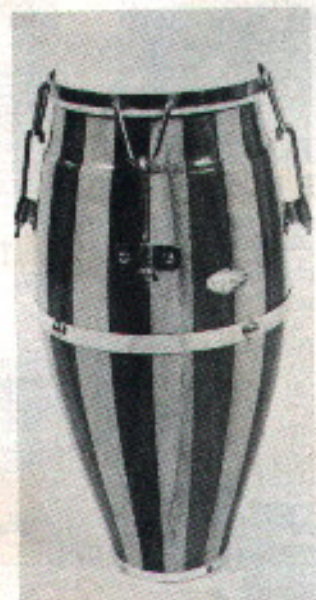

No. 4892 - TUNEABLE CONGA — SMALL BARREL SHAPED
Each \$39.00
Two-tone finish — 5 self-aligning tension lugs — Chrome hardware — 24" high, 8" head.

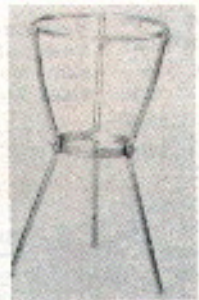

No. 170 — NEW STYLE ROUND CONGA STAND
Each \$14.25
Cradle type — Collapsible — Folds up small — All metal solid construction.

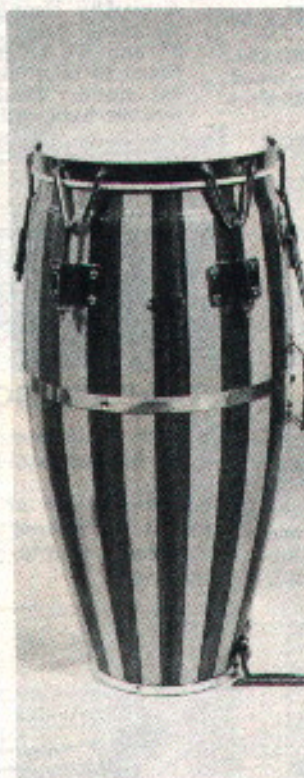

No. 4895 — TUNEABLE CONGA LARGE BARREL SHAPED
Each \$69.00
Natural two-tone finish — 5 self-aligning tension lugs — 30" high — 11" head.



TOY SIZE CONGAS

Miniature scale replicas, made just like the regular congas — strong heads, suspension strap, natural two tone wood, double curved.
No. 4904 — 12" high, 5" Head — Each \$9.75
No. 4297 — 16 1/2" high, 6" Head. Each \$13.50
No. 4923 — 8" high 3 3/4" Head. Each \$4.50



No. 4893 — TUNEABLE CONGA AFRO-CUBAN TYPE
Each \$75.00
Tri-colored — 5 Extra heavy tension lugs — Extra metal bands — Chrome hardware — 34" high — 11 1/2" head.

No. 4896 — TUNEABLE CONGA PROFESSIONAL — Each \$78.00
Large Round Mahogany Wood — Dark Mahogany finish — Gold color rings — 5 Extra heavy tension lugs — 30" high — 11" Mule skin head. Best Professional Conga at the price.



POPULAR MARACAS



No. 4956 ----- Pair \$3.50
 Mexican Wood Maracas — Hand made
 — Highly polished—Assorted Brilliant
 colors — Hand carved — Fine tone.



No. 4957 ----- Pair \$3.50
 Mexican Wood Maracas — Hand made
 — Highly polished — Natural finish
 — Native scenes — Excellent tone.



No. 100E ----- Pair \$5.00
 Extra Large Wood Maracas — Swish
 tone and distinct sound — Hand carv-
 ing — Assorted colors.



No. 4958 ----- Pair \$2.50
 Medium Small Colored
 Wood Maracas — Hand
 carved — Same finish as
 larger sizes



No. 4959 ----- Pair \$2.50
 Medium Small Natural
 Wood Maracas—Same fine
 finish as the larger models.



No. 127 ----- Pair \$.75
 Toy Shell Maracas — Made
 for School and souvenir
 trade. Assorted colors.

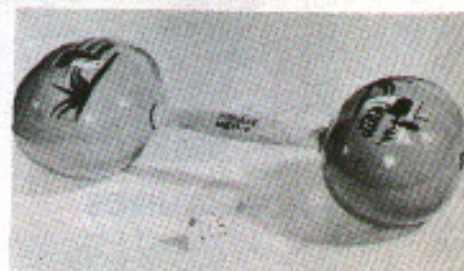

No. 113 ----- Each \$2.25
 Samba (Carioca) Maracas — Dumbbell shell
 Maracas. Two large, colored shells joined
 together with a wooden handle. Played with
 one hand only. Good for Sambas.



No. 121 ----- Pair \$1.35
 Small Shell Maracas —
 Made of Native gourd —
 Screw top handles — As-
 sorted colors — Hand
 painted scenes.



No. 102 ----- Pair \$1.80
 Medium Shell Maracas —
 Made of Native gourd —
 Screw top handles — As-
 sorted colors — Hand
 painted scenes.



No. 101 ----- Pair \$2.25
 Large Shell Maracas —
 Made of Native gourd —
 Screw top handles — As-
 sorted colors — Hand
 painted scenes.

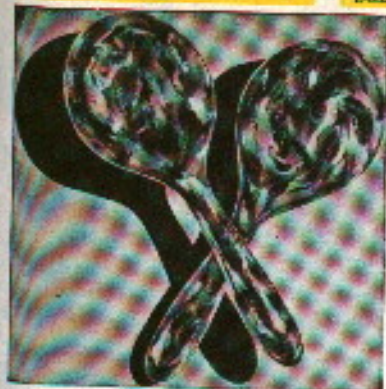

PLASTIC MARACAS

High grade polished Styrene Plastic.
 Crack-resisting against atmospheric
 changes. Colors: Assorted, high shade
 combinations.

No. 199—Maracas ----- Pair \$1.15

No. 136 ----- Pair \$2.25
 Small Natural Shell Mar-
 acas — Rattan wrapped
 handles — Hand painted
 scenes.

No. 104 ----- Pair \$3.00
 Medium Natural Shell
 Maracas — Rattan wrapped
 handles — Hand painted
 scenes.

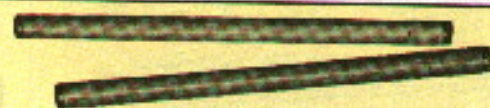

MARACA STICKS

No. 4749—A clever combination drum
 stick and maraca for Latin-American
 rhythm work. Length 12 1/4", diameter
 about 3/4". Per Pair ----- \$3.00 B



ETHEL SMITH Demonstrates the Maracas

(This picture of Miss Smith is taken from
 the book "Ethel Smith's Latin-American
 Rhythms" published by Ethel Smith Music
 Corp., and is used by special permission of
 publisher.)

LATIN - AMERICAN INSTRUMENTS

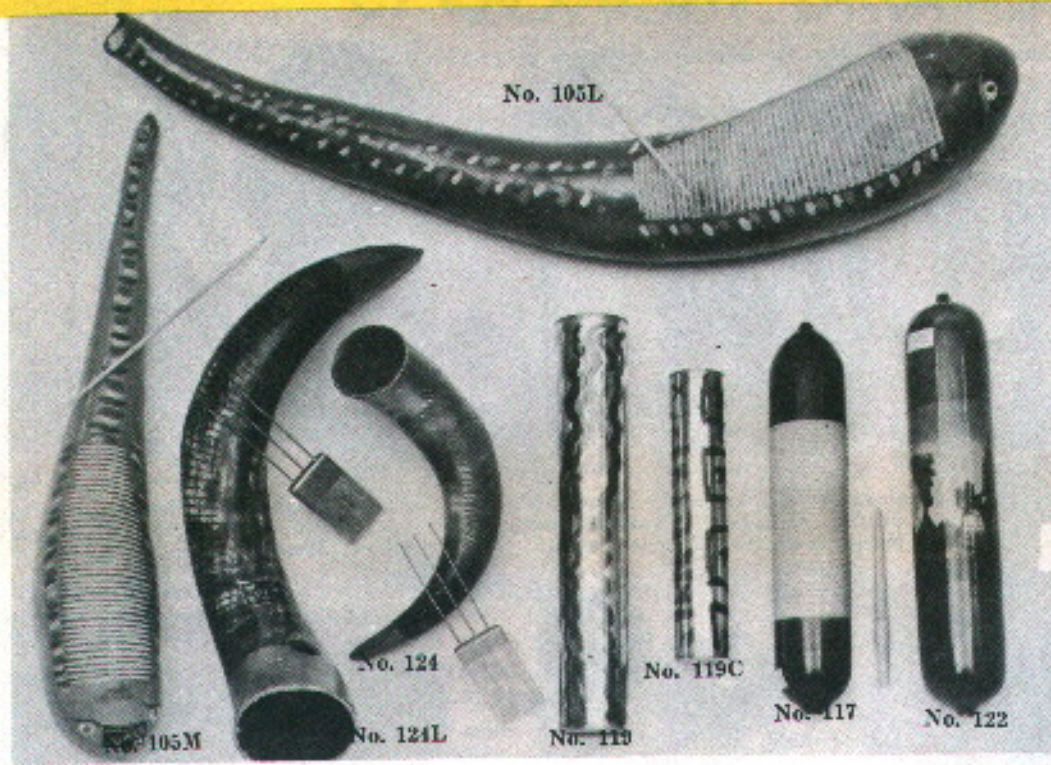

GOURDS (GUIROS)

The Gourd is a dried vegetable shell. It is played by scratching a stick over the deep ridges. These are made of native fruit, hand carved, and are obtainable in various bright contrasting colors. The finished product resembles life-like fish. Excellent tone and quality . . . a necessity for Rhumba, Samba and Mambo music. Small, medium and large sizes. With scratchers.

No. 105M—Gourds, medium --- \$4.50
 No. 105L—Gourds, large ---- 5.25

WOOD GUIROS

Wood Guiros are the mates to our wood Maracas and wood Shakers. Hand made of natural woods and carefully finished and polished. Complete with scratcher.

No. 117—Wood Gourds Each \$4.50

(All Gourds listed are furnished complete with scraper.)

WOOD SHAKER

Highly polished natural wood, with picture designs. A popular rhythm instrument with excellent tone.

No. 122—Wood Shaker Each \$4.50

COW HORN GUIROS

(Open End Models)

No. 124L—Extra large authentic Cowhorn Guiros (Gourds). Finely polished finish, good sharp tone. Supplied with three prong scraper Each \$6.00

No. 124—Cowhorn with scraper, Medium Each \$4.50

METAL TUBOS

(Chacolo)

No. 119—Tubos metal. Sealed at both ends, with seeds enclosed. Produces a swishing sound when shaken. Regular large size Each \$3.00

No. 119C—Tubos, metal, Small size. Each \$1.50



JAWBONE (Quija)

No. 4777—Large size, used in Latin American rhythm. Played by striking palm. Each \$12.00



ETHEL SMITH

Foremost Recording Artist Demonstrates the Cabaza

(This picture of Miss Smith is taken from the book "Ethel Smith's Latin-American Rhythms" published by Ethel Smith Music Corp., and is used by special permission of the publisher.)



CHROME TIMBALES

No. 4849C—Set of 2 Chrome Timbales with Chrome Floor Stand ---\$75.00

Shell sizes 18" x 6 1/2" and 11" x 6 1/2". Beaver tail tension casings. Metal hoops and hardware in heavy chrome-plated finish. De luxe adjustable chrome-plated stand is part of set.



TIMBALI STICKS

No. 4852—Length, 14" Pair \$.50

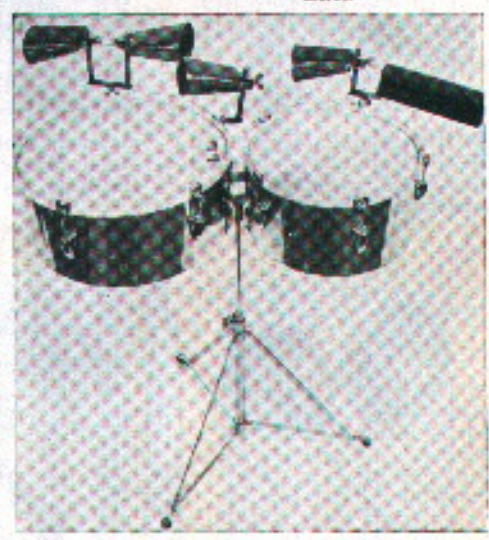

STANDS for TIMBALES

Instrument shown is not included

No. 1691—Floor stand of sturdy construction, adjustable. Nickel plated. Folds compactly, with brackets—Ea. \$13.50

No. 1691C—As above in CHROME finish. Special order only. Each, with brackets --- 15.00

TRAP HOLDERS FOR TIMBALI STANDS

Single Cowbell Holder Each No. 1661C—Chrome ---\$2.25

Double Cowbell Holder No. 1662C—Chrome ---\$3.00

Cowbell and Woodblock Holder No. 1663C—Chrome ---\$3.25

LATIN-AMERICAN DRUM RHYTHMS

Complete with studies and examples by Le Roy S. Weill.

\$1.25 D

CASTANETS, CLAVES and CABAZA



No. 500

SPANISH CASTANETS

Made of ebony; black highly polished, durable composition, moulded to the proper shape and form under hundreds of tons pressure. With red and yellow tasseled strand silk cord. Castanets are used in sets consisting of two pair. Packed two pair in box (one set).

Per Set

No. 500B—With Instruction Book, Set of four \$2.00



SPANISH CASTANETS

Regular size, made of Mexican native hardwood. Professional style.

No. 118—Per Set of two (2) pairs \$1.80



• EL GRANDE • CASTANETS

Made of superior quality native hardwood, richly finished with colorful cords. Typical Spanish style, large size.

No. 4960—Per Set of two (2) pairs \$2.25



No. 504 No. 505 No. 506

CASTANETS ON HANDLES

Double Action Castanets

One pair mounted at each end of hard wood ebonyized finished handle, fastened with gut.

No. 504 Each \$4.15

One Pair Castanets

Mounted on hardwood, ebonyized finished handles. Fastened with gut.

No. 505 Each \$2.75

Two Pair — Four Castanets

Mounted on hardwood, ebonyized finished handle. Fastened with gut.

No. 506 Each \$4.15



DE LUXE SPANISH CASTANETS

In Plastic Case

De Luxe Type Brown Finish Castanets.

Made from the highest quality material for the best tone, pitch and comfort in playing.

A Set (2 Pairs) in a beautiful Two-tone, Red and Crystal Clear Plastic Case, with new style Red and Yellow cords and Self-Instruction book.

No. 502—Set of 4 (2 pairs) and book in plastic case, \$2.75

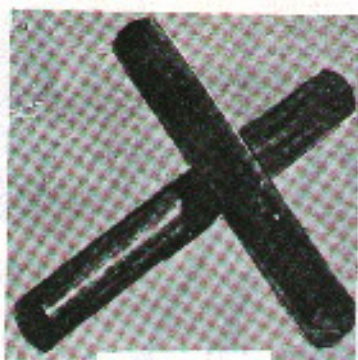

MEXICAN CLAVES

Large Deluxe Model

Well made de luxe Professional Claves. Highly polished finish.

No. 4961—Per Pair \$2.50

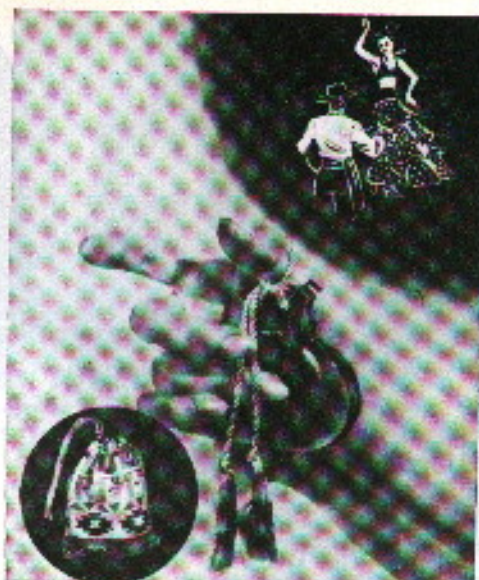

• FANDANGO • CASTANETS

Molded of durable composition, especially designed for fine tone. Supplied with colorful strings. Sets of 4 (for 2 hands) are packed in attractive pouch.

Number Per Set of 4

1120 —Polished Black \$2.00

—With Instruction Book,

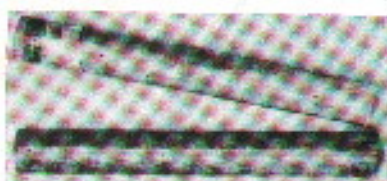

JUNIOR CLAVES

Light and dark colored hardwoods, suitable for children's rhythm work.

No. 123B—Per Pair \$1.00



MEXICAN CLAVES

Medium Size

Native hardwood in various shades polished finish. Fine tone, professional quality.

No. 123—Per Pair \$1.80



Brazilian Gourd or Cabaza. A "Must" for Samba Music.

THE CABAZA

The Cabaza is used mostly in Brazilian music. It is a large maraca-like instrument covered with a loose net of beads. It is held by the stem with the right hand, so that its head rests on the palm of the left, and is played by half-rotating the Cabaza with a twisting movement of the wrists.

No. 4962—Cabazas, large size Each \$15.00

TRIANGLES - TEMPLE BLOCKS - BONES

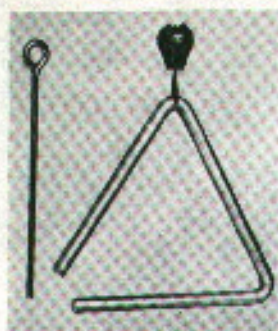

ANODIZED ALUMINUM TRIANGLES

New lightweight triangle that produces a true triangle tone without the weight of steel. Comes complete with triangle striker and holder integral with triangle.

No. A5—Triangle 5"	\$1.35
No. A6—Triangle 6"	1.50
No. A7—Triangle 7"	1.75

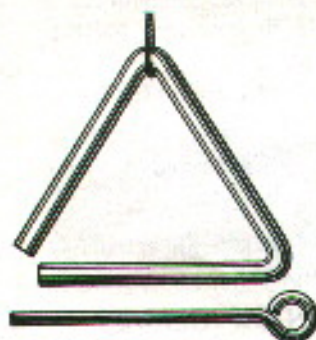

• KLEARTONE • TRIANGLES

Klearitone triangles are made of extra heavy gauge steel. Brilliant tone. Beaters included.

No. 4713—Size 5"	Each \$1.20
No. 4714—Size 6"	Each 1.35
No. 4715—Size 8"	Each 1.65
No. 4716—Size 10"	Each 2.10

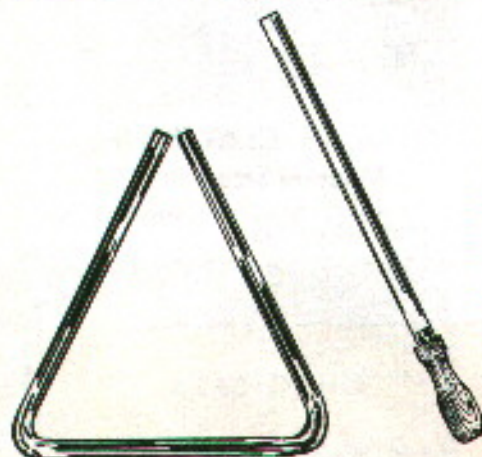

PROFESSIONAL ALUMINUM TRIANGLES Superior, Clear Tone

These triangles are made from 1/2" round highly polished aluminum alloy, and are superior to steel as they have a clearer tone, more volume and longer carry, also are lighter in weight. The beater is 12" overall length, with a 4" long wood handle and a 3/8" round x 8" long plastic striking rod.

No. 612—Size 6"	\$2.10
No. 812—Size 8"	2.40
No. 1012—Size 10"	3.30
No. 1212—Size 12"	4.05

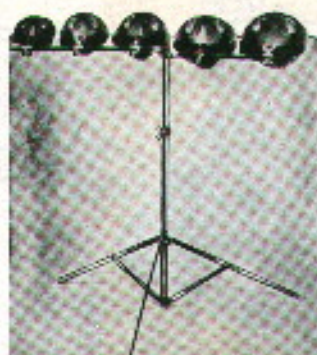

TEMPLE BLOCK FLOOR STAND

Blocks are NOT Included
No. 766—"Perfection." Holds five temple blocks. Folds compactly. Adjustable to height. Complete with 5 clamps to hold temple blocks.
Each

\$15.00



TEMPLE BLOCK HOLDER

No. 1016—Perfection. Holds individual blocks. Attaches to trap table post or hoop adapter.

Each

\$1.20

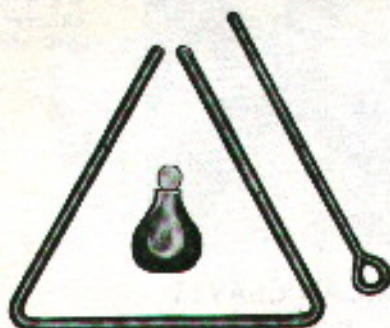

• BUCKEYE • TRIANGLES

Buckeye triangles are made from 1/4 inch round special grade steel, nickel plated. Beaters included.

No. 4710—Size 5"	Each \$0.55
No. 4711—Size 6"	Each .70
No. 4712—Size 7"	Each .85
No. 4719—Buckeye Triangle Holder. Wood knob handle with cord loop	Per Doz. \$3.60



Oriental Temple Blocks

Hand carved Temple Blocks, deep toned and artistically lacquered in reddish brown, black and gold.

No.	Each
4871—4 1/2" Temple Block	\$ 6.00
4872—5" Temple Block	7.00
4873—5 1/2" Temple Block	10.00
4874—6" Temple Block	10.00
4875—6 1/2" Temple Block	10.00
4876—Complete set of five, per set	39.75



• KLEARTONE •

EBONIZED RHYTHM BONES

No. 4740—Ebonized, 7 inches long. Per set of 4 \$1.50



FAMOUS • BIRL • RHYTHM BONES

(With Patented Grooves)

Plastic Rhythm Bones with patented grooves eliminate pressure on fingers. Comfortable grip makes it easier to hold and play. Permits continuous play without fear of bones flying from hand. Mounted on card with instructions for playing.

No. 4741—Rhythm Bones. Per set of 4 (2 pairs) \$1.50B

AFRICAN WHITE BONES

Genuine white bones imported from Africa. Excellent tone.

No. 4748—Per Set of 4

\$3.00

INDIAN TOM-TOMS

Colorful Tom-Toms, rubber heads. Rawhide covered mallet with each Tom Tom. Shell decorated with colored feathers of red, yellow and blue. Heads will tighten and loosen according to humidity.

No.	Each
004T—4 1/2" x 5"	\$.98
003 —6 1/2" x 7"	1.98
008 —12" x 4 1/2" with Thunderbird insignia painted on head	4.98



DRUMMERS' TRAPS

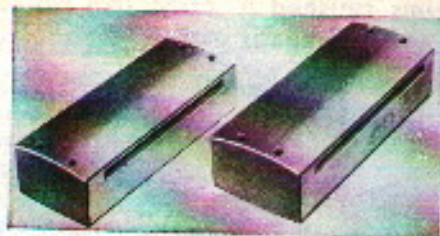

Medium Large

•ROGERS• WOOD BLOCKS-Professional Quality

Made of selected wood, especially adapted for authentic wood block tone. Slotted top and bottom. Carefully shaped and neatly bevelled. Attractive reddish brown or natural finish. Fit standard holders.

- No. 4816R—Medium, 6 $\frac{1}{2}$ " , shaded reddish brown ----- Each \$2.50
 No. 4817R—Large, 7 $\frac{1}{2}$ " , shaded reddish brown ----- 2.75

•ROGERS•

WOOD BLOCK HOLDER

- No. 4805 — Hoop Mount. Holds any size wood block. Nickel plated. Each ----- \$.90
 No. 4805C — Same. Chrome plated. Each ----- \$1.20



COW BELL HOLDERS

- Nickel Plated
 Single cow bell holder
 No. 429 ----- Each \$1.20



TUNED COW BELLS

Made in U.S.A. Height Includes Loop

COPPER COWBELLS		CHROMED COWBELLS	
No.	Each	No.	Each
No. 4786—3 $\frac{1}{2}$ "	\$1.75	No. 4787C—4 $\frac{1}{2}$ "	\$2.95
No. 4787—4 $\frac{1}{2}$ "	1.95	No. 4788C—5 $\frac{1}{4}$ "	3.50
No. 4788—5 $\frac{1}{4}$ "	2.25	No. 4789C—5 $\frac{3}{8}$ "	4.50
No. 4789—5 $\frac{3}{8}$ "	2.50	No. 4790C—6 $\frac{1}{8}$ "	4.95
No. 4790—6 $\frac{1}{8}$ "	2.95		

• ZIL BEL • COW BELLS

by A. ZILDJIAN

- No. 4604—6 inch size, Polished Chrome Ea. \$10.00B
 No. 4605—6 inch size, Dull Chrome — Each \$8.00B
 No. 4606—4 $\frac{1}{2}$ inch size, Polished Chrome Ea. \$9.00B
 No. 4607—4 $\frac{1}{2}$ inch size, Dull Chrome — Each \$7.00B

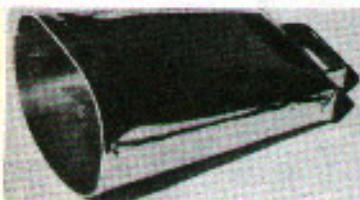

•ROGERS• ADJUSTABLE WOOD BLOCK ATTACHMENT

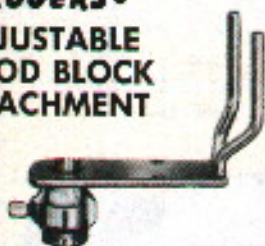

- No. 282R—Attaches to any round or hex rod. Permits any playable height or position. Chrome-Plated ----- Each \$3.50

•ROGERS• "STA-TITE" COWBELL HOLDER

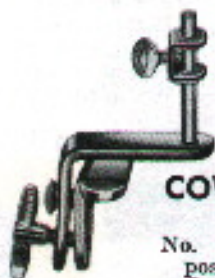

- Chrome Plated
 No. 4656—With 6 inch post and "U" clamp. Complete ----- Each \$3.00
 No. 4796 — "U" Clamp only with thumb screw, chrome plated ----- Each \$.50



COWBELL HOLDER ASSEMBLY

- Chrome Plated
 No. 239R — 7 inch arm with "U" clamp. Deluxe chrome plated. Will fit "Wonder Bar", shell mount or hoop clamp. ----- Each \$1.50

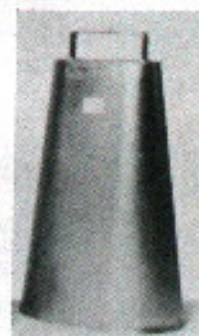

Large Mexican Rumba Cowbells

- No. 178—10 inch ----- Each \$7.50
 No. 179—12 inch ----- Each 9.00



HALF MOON TRIAD

- No. 1722—For small bass drums. Puts block and bells high. Nickel-plated ----- Each \$4.50

•ROGERS• COWBELL HOLDER ASSEMBLY

- Chrome Plated
 No. 280R—Adjustable to height or angle desired. Can be attached to any round or hex rod. Eliminates hoop mounting ----- Each \$4.50

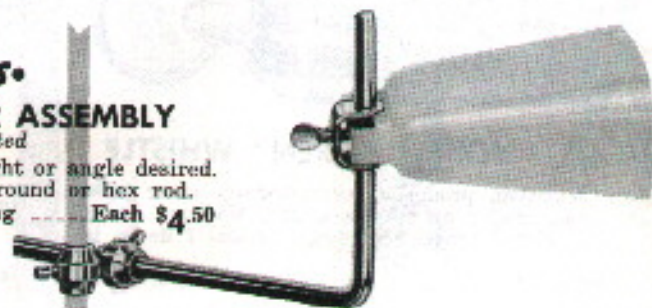

•ROGERS• COMBINATION COW BELL & WOOD BLOCK HOLDER

- Chrome Plated
 No. 4813 — Designed for any playable height or position. Permits placing of cow bell and wood block where desired. ----- Each \$6.00

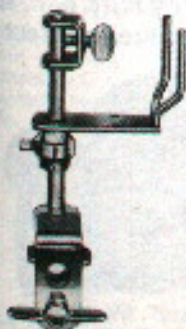

QUICK-HITCH TRIADS

- Block holder adjustable to any size block, bells to any angle.
 No. 1502 ----- Each \$3.75



• CHAMPION • TOM-TOMS

- Regular 10"x4" size, with two tacked heads.
 No. 4704W—White ----- } \$8.25
 No. 4704B—Black ----- } Each

•ROGERS• QUALITY TAMBOURINES

A complete line of professional quality tambourines with solid maple rims finished in attractive walnut. Professional nickel-silver jingles superior in tone quality. Waterproofed (lacquered) heads will resist sagging or pulling caused by atmospheric changes.

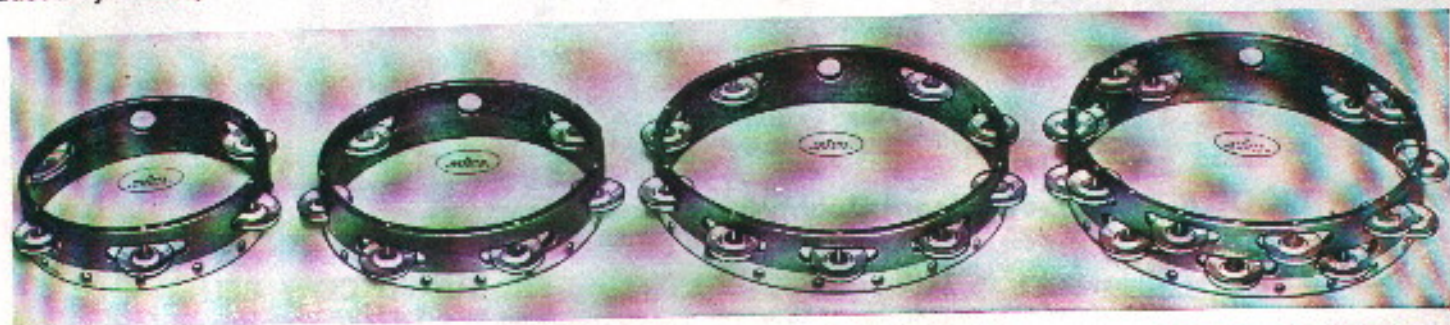

No. 4720—Size 7 inch.
5 pr. Jingles
Each \$3.95
(3 Doz. to Carton)

No. 4721—Size 8 inch.
6 pr. Jingles
Each \$4.75
(3 Doz. to Carton)

No. 4722—Size 10 inch.
9 pr. Jingles.
Each \$6.40
(1 Doz. to Carton)

No. 4732—Size 10 inch.
Double row, 17
pr. Jingles Ea. \$8.40
(1 Doz. to Carton)



•ROGERS• STUDIO TAMBOURINES

Two-piece split rim style, maple finish, high grade jingles, waterproofed heads. Popular, moderately priced line.

Waterproofed Heads

No. 4791—6"—
5 sets Jingles \$3.25
No. 4792—7"—
6 sets Jingles 3.60
No. 4793—8"—
9 sets Jingles 4.50
No. 4794—10"—
12 sets Jingles 5.75

TAMBOURINE JINGLES

No. 4735 — Professional quality, nickel-plated, good tone.
Each \$.07
Per 100 6.50
Per 1000 60.00



NO NAIL TAMBOURINE

Patented metal rim holds head. No nails or tacks to tear the head or weaken the frame. Easy to re-head. Polished walnut finish. 10 inches, 12 sets jingles.

No. 989B Each \$10.75



• BLASTO •

DRUM MAJOR WHISTLE

No. 25—Professional. Tongue and groove riveted. Black or Red plastic. Genuine cork ball. Packed 12 to display box.

List Price Dozen \$3.60



FAMOUS • ACME • "SIREN" WHISTLE

Especially sensitive, producing exceptionally clear tone. Ideal for drum major or orchestra use. Made of finest quality nickel-plated brass. 3 1/4" long. Packed 1 dozen to box.

No. 27—"Siren" Whistle Each \$3.75



• ACME • WRIST WHISTLE

No. 31—A very popular whistle, mounted on quality leather strap.

Each \$3.00

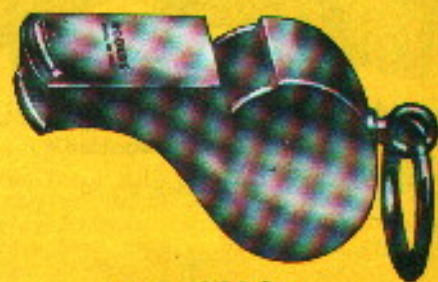

• ROGERS • DRUM MAJOR WHISTLE

Professional, KING size, metal whistle. America's finest. Genuine Cork ball. Easy-blowing, loud full tone. Bright nickel plated. Individually boxed. Big value.

No. 29—Rogers Drum Major Whistle
Made in U. S. A. Each \$1.25

• ACME • PROFESSIONAL DRUM MAJOR WHISTLES

Made in England. World's finest professional whistles. Brass, bright nickel-plated. Highest quality cork ball, sensitive to the slightest breath of air; loud and powerful. Individually tested at factory, hence guaranteed perfect.



No. 21—Acme Special, 2 in. long
Dozen to box Each \$1.00



No. 23—Acme "Junior," 2 in long.
Dozen to box Each \$1.35



No. 26—Acme "Standard". 2 1/2 in. long
Dozen to box. Each \$1.25

DRUMMERS' TRAPS

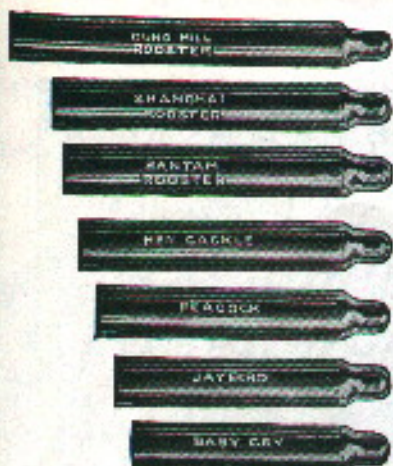

METAL IMITATIONS

- No. 540—Dunghill rooster
- No. 541—Shanghai rooster
- No. 542—Bantam rooster
- No. 553—Hen cackle
- No. 554—Peacock
- No. 555—Jaybird
- No. 556—Baby cry

Each
\$1.50

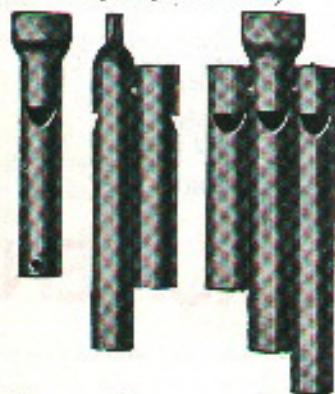

METAL WHISTLES

- No. 824—3-tone Locomotive whistle
- No. 826—2-tone Interurban whistle
- No. 827—Cuckoo

Each
\$9.00
7.50
3.00



WOOD IMITATIONS

- No. 1M—Locomotive or steamboat
- No. 4L—Ocean liner

Each
\$12.00
13.50



HAND CYMBALS

Made in spun brass and furnished with web straps. Effective for dancing specialties, clowning acts, and children's rhythm band groups.

- No. 4300—Complete with straps, 7 inch.

SLAP-STICKS



- No. P116

Each \$4.50



- No. 123—Dog bark

Each
\$2.25



- No. 138—Lion Roar or Bear Growl

\$12.00



- No. 560—Double Ratchet

Each \$6.50



AMERICAN SONG WHISTLE

- No. 302—Song Whistle, 12" long. Easy slide action.

Each \$3.65



- No. 567—13 sleigh bells on handle
- No. 568—25 sleigh bells on handle
- No. 566—12 sleigh bells on strap

Each
\$6.75
10.50
4.50



- No. 564—Bell plate

Each \$5.00



- No. 37—Pop gun

Each \$6.00

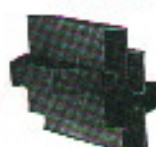

- ROGERS • SAND BLOCKS
- No. 4731—Good quality.

Per Pair \$1.00



• TROPHY • PLASTIC SONG WHISTLE

Plastic, Yellow Body with Contrasting (Patented) Mouthpiece with Leak-Proof Plunger and Looped Rod. Size 10" Long. Individually Boxed.

- No. 30—Per Dozen \$5.76



- No. K-15—Quail Imitation

Each \$1.50



- No. 135—Bob White

Each \$1.80



No. 56

BIRD WHISTLES

Used with Water

- No. 59—Perfection, popular model
- No. 56—Perfection, better grade

Each
\$2.25
3.00



• ROGERS • SLEIGH BELLS

- No. 4742—Four 1-inch nickel-plated bells mounted on 3/8" elastic wrist band

Each \$.30

- No. 4743—Four 1-inch nickel-plated bells mounted on 3/8" webbed strap

Each .45

- No. 4744—Three 1 1/4" full toned, high quality, bright nickel-plated bells. Produces 2 sleigh bell effect. Mounted on 1" webbed strap. Used on wrist or held in hand

Each .75



No. 4706



No. 4707

• ROGERS • RHYTHM BELLS

- No. 4706—Made from brass, bright nickel-plated with 1 3/8" bell. Has double clapper. Produces clear ringing tinkle. Ideal for rhythm bands. Adjustable leather strap.

Each \$1.00

- No. 4707—Made from brass, bright nickel-plated, black enameled wooden handle. Pleasing tone.

Each \$.60

• ROGERS • RHYTHM BAND OUTFITS



No. 982—16 Player Group Per Outfit \$9.75

An ideal outfit for kindergarten and 1st or 2nd grade grammar school classes, or for small groups. Good starter outfit, to which other parts can be added as enrollment increases.

Consists of:

- 4 Jingle Clogs (for 4 pupils)
- 6 pairs Rhythm Sticks, 1 fluted, 1 plain (pr. to pupil)
- 2 Sleigh Bells or Wrist Bells (for 2 pupils)
- 1 Tone Block and Beater
- 1 Rhythm Bell
- 1 Pair Metal Cymbals (for 1 pupil)
- 1 Triangle, Beater and Holder
- 1 Director's Baton, standard model
- 1 Standard Rhythm Band Instruction Book

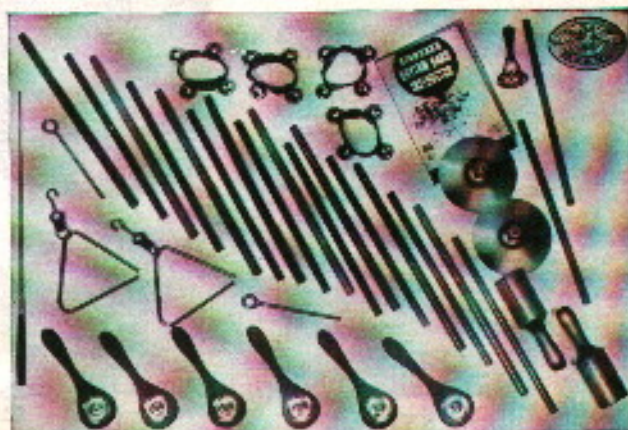

No. 984—24 Player Group Per Outfit \$13.50

Practical for larger starting groups in elementary classes or in kindergarten. These colorful instruments have great appeal to children. Other instruments can be added for tonal variety.

Consists of:

- 8 Jingle Clogs (for 8 pupils)
- 8 pairs Rhythm Sticks, 1 fluted, 1 plain (pr. to pupil)
- 4 Sleigh or Wrist Bells (for 4 pupils)
- 2 Tone Blocks and Beaters (for 2 pupils)
- 1 Rhythm Bell
- 1 pair Metal Cymbals (for 1 pupil)
- 2 Triangles, Beaters and Holders (for 2 pupils)
- 1 Director's Baton, standard model
- 1 Standard Rhythm Band Instruction Book

• ROGERS • RHYTHM BAND INSTRUMENTS



No. 4819

• ROGERS • TONE BLOCKS

No. 4819—Tone Block with Beater Each \$1.25

Made of selected wood—one-piece construction 8 1/2" overall. Handle shaped for comfortable grip. Barrel is bored and slotted to produce characteristic wood block tone effect. Nicely finished. Wooden beater included. Popular in rhythm bands.



No. 4747

No. 4747—Rhythm Gourd with Scratcher—Each \$1.50

Rogers Rhythm Gourd. Measures 7 3/4" overall. Made of selected hardwood, one-piece construction, best suited for acoustical results. Finished in walnut. Barrel is slotted and ribbed for Latin-American type rhythm effect. Supplied with wooden scratcher.

DIRECTOR'S BATON

No. 22C—Standard model, white birch, 18" long, ideal for beginner's outfit Each \$.35

No. 15C—Director's Baton. Professional style baton, carefully tapered, with turned handle. 18 inches long, finished in two harmonizing colors Each .85



RHYTHM CYMBALS

Brass, 7" size, with knobs for holders.

No. 4317 Per Pair **\$4.85**



• ROGERS • RHYTHM STICKS

Made of seasoned wood in the popular sizes for rhythm bands. Finished in attractive standard colors.

No. 4745—Rhythm sticks, plain Pair \$.25

No. 4746—Rhythm sticks, one plain, one fluted Pair .35

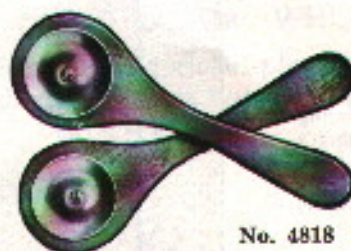

No. 4818

• ROGERS • JINGLE CLOGS

A most popular Rhythm Band instrument. Consists of wooden handle, shaped for comfortable grip, neatly finished. Two high quality, regulation tambourine jingles mounted on each handle. Used by tapping against palm of hand or by waving like a tambourine. Supplied in bright colors.

No. 4818—Jingle Clogs. Pair of two handles, as shown . . . \$.80

• PERFECTION • RHYTHM OUTFITS

A standard selection of popular and accepted kindergarten instruments put up in Rhythm Band Outfits to fit all occasions. These outfits in single units or intermixed will equip small or large groups, as needed.

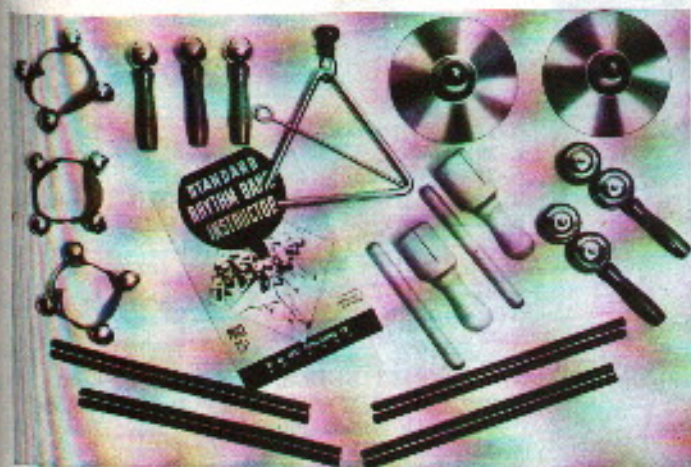

No. 216—Perfection 16 Pupil Outfit \$9.95

Consists of the following:

- | | |
|----------------------------|-----------------------------------|
| 4 pr. Rhythm Sticks | 2 Jingle Clogs |
| 2 Tone Blocks with Mallets | 1 Triangle and Beater |
| 2 Sleigh Bells | 1 pr. Cymbals |
| 1 Wrist Bells | 1 Standard Rhythm Band Instructor |



No. 222—Perfection 22 Pupil Outfit \$13.80

Consists of the following:

- | | |
|----------------------------|-----------------------------------|
| 5 pr. Rhythm Sticks | 4 Jingle Clogs |
| 2 Tone Blocks with Mallets | 2 Triangles and Beaters |
| 4 Sleigh Bells | 1 pr. Cymbals |
| 4 Wrist Bells | 1 Standard Rhythm Band Instructor |



No. 230—Perfection 30 Pupil Outfit \$25.35

Consists of the following:

- | | |
|----------------------------|-----------------------------------|
| 6 pr. Rhythm Sticks | 4 Jingle Clogs |
| 4 Tone Blocks with Mallets | 2 Triangles and Beaters |
| 4 Sleigh Bells | 2 Castanets |
| 4 Wrist Bells | 2 Tambourines |
| 2 pr. Cymbals | 1 Standard Rhythm Band Instructor |

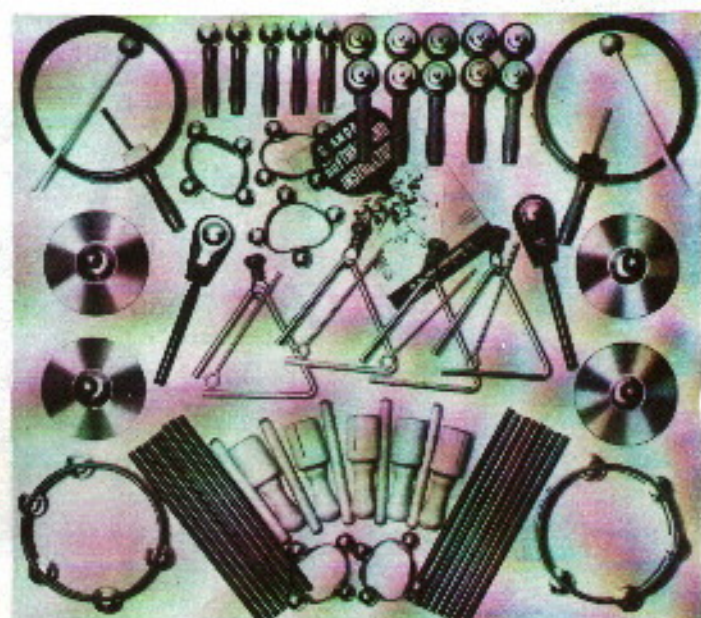

No. 240—Perfection 40 Pupil Outfit \$34.50

Consists of the following:

- | | |
|----------------------------|-------------------------|
| 8 pr. Rhythm Sticks | 5 Jingle Clogs |
| 5 Tone Blocks with Mallets | 4 Triangles and Beaters |
| 5 Sleigh Bells | 2 Castanets |
| 5 Wrist Bells | 2 Tambourines |
| 2 pr. Cymbals | 2 Hand Drums |
| | 1 Instruction Book |

PERFECTION • RHYTHM INSTRUMENTS

A Standard and Complete Line of Tried and Tested School Accepted Instruments.

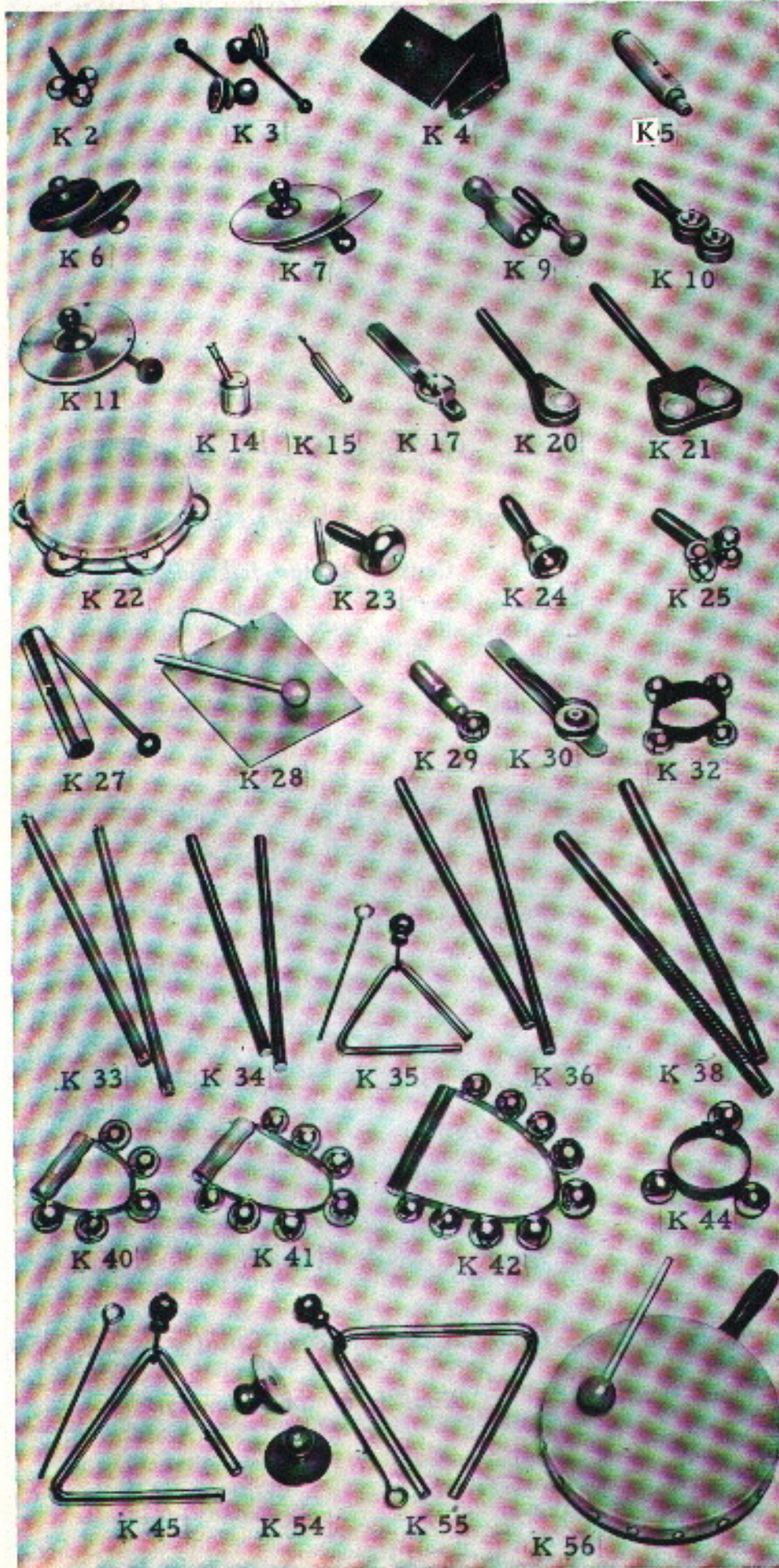

No.		Price
K-2	SLEIGH BELLS	Each \$0.75
K-3	JINGLE HAMMERS	Pair .90
K-4	SAND BLOCKS	Pair 1.35
K-5	CUCKOO	Each 1.20
K-6	WOOD CYMBALS	Pair 1.50
K-7	METAL CYMBALS	Pair 1.32
K-9	TONE BLOCK and MALLET	Set .75
K-10	JINGLE CLOGS	Each .80
K-11	TAP TAP	Each 1.80
K-14	BIRD WHISTLE	Each 2.25
K-15	QUAIL	Each 1.50
K-17	JINGLE STICK	Each .60
K-20	CASTANETS	Each 1.48
K-21	CASTANETS, Double	Each 2.50
K-22	TAMBOURINE, 7" Red Shell	Each 4.25
K-23	RHYTHM BELL & MALLET	Set .90
K-24	LIBERTY BELL	Each 1.35
K-25	SLEIGH BELLS	Each .75
K-27	CHIME (low pitch A)	Each 1.98
K-28	GONG	Each 1.98
K-29	SLEIGH BELL	Each .45
K-30	JING-A-LING	Each .60
K-32	WRIST BELLS, 4 on strap	Each .45
K-33	RHYTHM STICKS, 12" DeLuxe, Plain With Nickel Ferrules	Pair .45
K-34	RHYTHM STICKS, 10" Plain	Pair .20
K-35	TRIANGLE, 4", Striker, Holder	Set .99
K-36	RHYTHM STICKS, 12" Plain	Pair .80
K-38	RHYTHM STICKS, Both Notched	Pair .40
K-40	SLEIGH BELLS, 5 on Frame	Each 1.05
K-41	SLEIGH BELLS, 7 on Frame	Each 1.50
K-42	SLEIGH BELLS, 9 on Frame	Each 2.00
K-44	WRIST BELLS, Professional	Each .60
K-45	TRIANGLE, 5" Striker, Holder Set	1.15
K-54	PAT-A-CAKE, Metal	Pair .60
K-55	TRIANGLE, 6", Striker, Holder Set	1.48
K-56	HAND DRUM, 6", With Handle, Underside Snare and Mallet	Set 3.75

DRUMS FOR RHYTHM BANDS



No. F4221

• SKIPPER • SNARE DRUMS

No. F4219—"Skipper" Juvenile Snare Drum. Size 4"x10". Mahogany finish, maple hoops Tax Paid \$10.95

Has 4 convenient thumb-grip rods, wire-wound snares, adjustable strainer. Good skin heads.

• LITTLE GIANT • PARADE

No. F4244—"Little Giant" Juvenile Parade Drum. Size 8"x10". Mahogany finish shell, maple hoops, natural finish \$18.00

Has 4 convenient thumb-grip rods, silk wire-wound snares, adjustable strainer. Sling holder. Quality skin heads. No slings or sticks.

• SPECIAL • SNARE DRUMS

No. F4220—"Special" drum. Size 5"x13". Mahogany finish shell, maple hoops \$21.00

No. F4221—Same, All White \$21.50

Regulation size Junior Drum. 6 single tension key-rods, wire-wound snares, adjustable strainer. Good heads. Priced for lowest budget.

MELODY, RHYTHM and TUNED BELLS

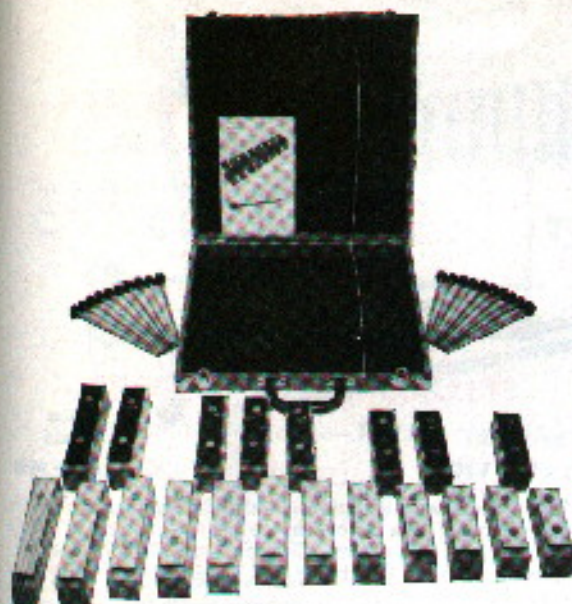

TUNED RESONATOR BELLS

Individual resonator bell set consists of 20 accurately tuned chromatic bells, pitched to A440, and ranging from C to G. Scale letter is clearly stamped on each bar. Diatonic notes are finished in white, half-tones in black, mounted on a natural finish resonator box. Compact, sturdy, brown tweed case. Set is complete with bells, case, 20 soft rubber mallets and four page instruction book.

No. F1700—Bells in case. (Bells are arranged so that they may be played in case as a set of melody bells, or removed for use as individual bells.) **\$73.00B**

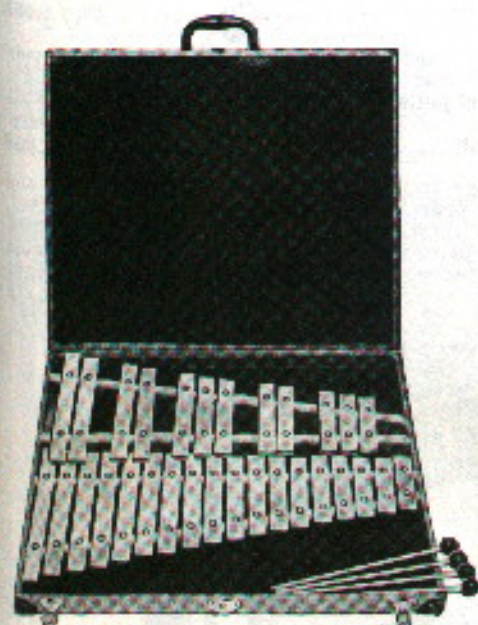

PROFESSIONAL ORCHESTRA BELLS

Highly polished aluminum alloy bars $\frac{3}{4}$ "x1", tuned to A440. In gray tweed case, reinforced corners. Two pair mallets included.

No.	Fed. Tax Paid	Each
1026—2½ octaves, G to C,		\$130.00
weight 16 lbs. -----		

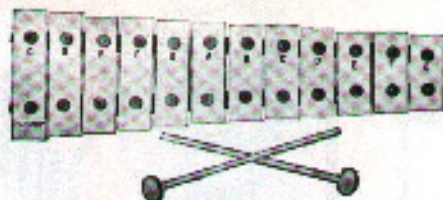

DIATONIC RHYTHM BELLS

White baked lacquer finish, tempered steel bars, accurately tuned to A440. Mounted on natural finish wood frame. Scale letters stamped on bars. Complete with mallets and instructions.

No.	Fed. Tax Paid	Each
18—C to C, 8 bars, 1"x½"	-----	\$6.10
112—C to G, 12 bars, 1"x½"	-----	7.40

CHROMATIC RHYTHM BELLS

In Cases

The chromatic rhythm bells in an attractive gray tweed, sturdy, carrying case.

No.	Fed. Tax Paid	Each
1420C—C to G, in case -----		\$26.25
1425C—A to A, in case -----		30.20
1427C—C to C, in case -----		30.20



BELL STAND

No. 219—Perfection. A durable and serviceable stand, full nickel-plated. Adjustable to height.

Each **\$11.00**



TUNED TIME BELLS

Highly recommended for rhythm hands. Each bell is mounted on a wood block and stamped with the scale letters. Complete with mallets and a four page music sheet.

4737—8 bell set, C to C diatonic, in a cardboard box with 8 mallets	\$19.65
4738—20 bell set, C to G chromatic, in a cardboard box with 20 mallets	42.60
4739—20 bell set, as above, complete in a keratal covered carrying case.	51.90

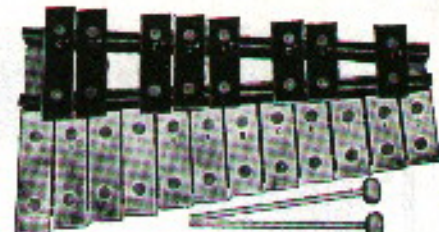

CHROMATIC RHYTHM BELLS

Tempered steel bars finished in black and white as on a piano keyboard. Complete with mallets and instructions.

No.	Fed. Tax Paid	Each
1420—C to G, 20 bars, 1½"x½"	-----	\$13.50
1425—A to A, 25 bars, 1½"x½"	-----	17.65
1427—C to C, 25 bars, 1½"x½"	-----	17.65

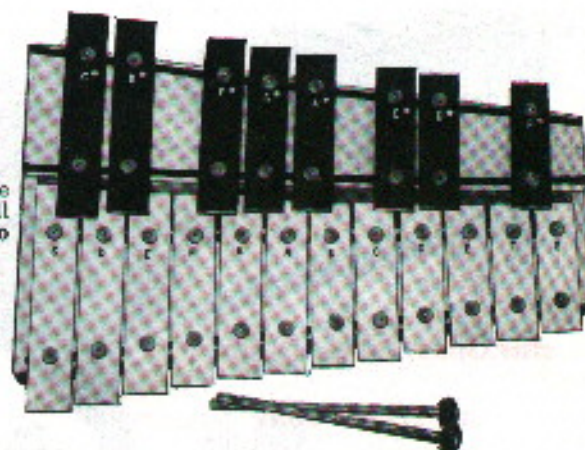

RESONATED MELODY BELLS

Because of many requests from music educators, this popular set of bells with many improvements, has been revived. Excellent for demonstrating the exact sound belonging to each letter or note of the chromatic scale. Beautiful birch wood frame is a scientifically designed resonator box which amplifies the sound of each note. Accurately tuned to A440, special steel bars 1½" x ½" finished in black and white to resemble piano keyboard. 20 notes, C to G, 1½ octaves, chromatic.

No.	Fed. Tax Paid	Each
2014—Resonated Melody Bells -----		\$29.70
2014C—Resonated Melody Bells in case -----		43.75
<i>Mallets included with bells</i>		

POPULAR INSTRUCTION BOOKS

by Alma S. Eybel

Belwin Method Of Song Bells, Book 1	Each
Belwin Method Of Song Bells, Book 2	.75D
Belwin Method Of Song Bells, Book 3	

MARIMBAS and VIBRAPHONES

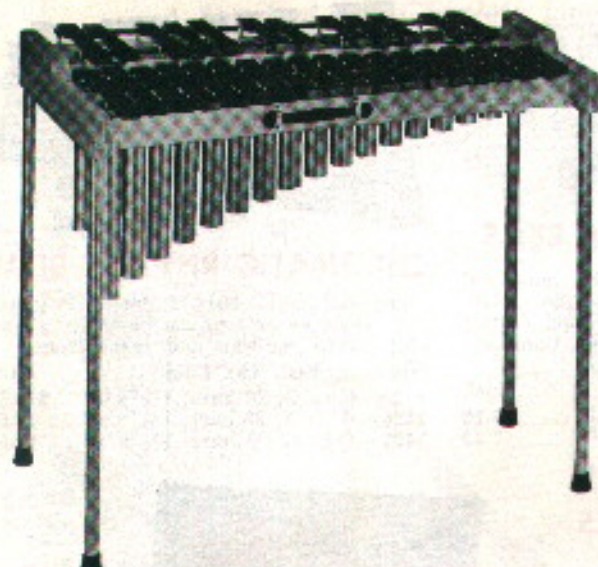

• PREP • MARIMBA

Leading Mallet-Played Preparatory Instrument. The Prep Marimba was designed for student use, yet has an unusually full tone.

Finely designed features — easily removed resonators — strong tubular legs which snap on and off in a jiffy. Completely portable and light weight. Outstanding feature is wider tone bars.

SPECIFICATIONS: Keyboard: 2½ octaves, C to F. Bars: 1½" x ¾". Height: 33 inches. Width: 27 inches. Length: 36 inches. Weight: 22 pounds. Mallets included.
No. 20—Prep Marimba Tax Paid \$165.00B

No. 4993—Musser-Yoder Modern Marimba Method Each 1.00



No. 452

STREAMLINE APPEARANCE

BRILLIANT TONE QUALITY

Tax Paid

No. 461—JENCO 3 OCTAVE MARIMBA \$395.00B

F to F range. Hardwood frame, lacquered with air-brush trim. Bars are Honduras Rosewood, stained and matched, and range in size from 1¾" to 1¼" in width. Expertly tuned. Detachable all metal resonators. Bars do not come off when folded. Mounted on casters. Legs fold. Can be easily carried. Frame measures: 30" wide, 34" high, 45½" long. Wt. 48 lbs.

No. 451—JENCO 4 OCTAVE MARIMBA TAX PAID \$595.00B

Modern styling. Honduras Rosewood bars, C to C range, graduated in size from 2¼" to 1¼" in width, beautifully matched and stained.

Frame made from hardwood, in gold and black lacquer. Easily set up, bars come off and rails fold in center. Resonators are polished aluminum, in four pieces, and the cross bar is in two pieces. Measurements: 72" long, 34" wide, 34" high. Wt. 100½ lbs.

No. 456—JENCO DELUXE 4 OCTAVE MARIMBA TAX PAID \$795.00B

This model is beautifully finished in blonde with arched resonators. This Marimba is a fine TV or Stage model with massive appearance—solid ends, and slanted sharp bars. Mounted on casters, can be easily dismantled and moved around.

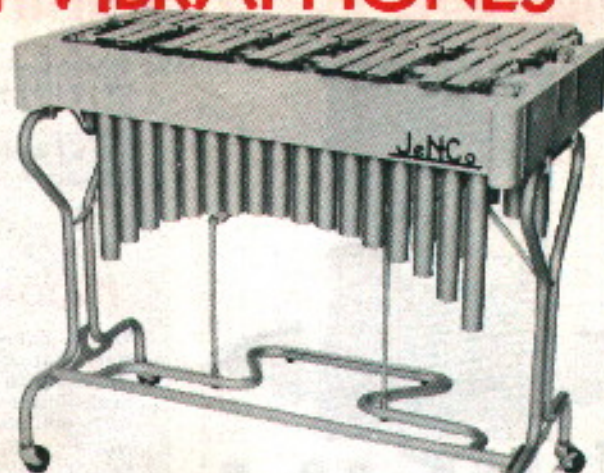

No. 441—JENCO 2½ OCTAVE VIBE Tax Paid \$425.00B

C to F range. Bars are 1½" x ½" polished aluminum. Beautiful appearance with side rails and ends covered with pearl plastic or choice of five colors in flash pearl. All metal, baked finish, arched resonators. Silent motor. Easily carried. Mounted on 2½" casters. Measurements: 33" high, 38" long, 27" at wide end and 14" small end. Weight 57 lbs.



No. 410

EASY TO SET UP AND DISMANTLE

No. 421—JENCO 3-OCTAVE VIBE Tax Paid \$575.00B

F to F range. Bars are uniform throughout—1½" wide. Side rails and ends covered with white pearl plastic. Measurements—46" long, 31" wide, 31" high. Wt. 81 lbs. New features are 3-speed pulley on motor and bright chrome plated finish on damper and legs.

No. 411—JENCO 3-OCTAVE VIBE TAX PAID \$695.00B

3 octaves, F to F range. Bars range from 2" x ¾" to 1½" x ½". Side rails and ends are covered with white plastic pearl. Width of frame at widest part 31½", narrow end 13½", length 50½", 33" high. Wt. 83 lbs. Metal arched resonators, and equipped with 2½" casters. 2 pairs mallets and bar cover furnished with each Vibe. New bright chrome plated on finish on legs and 3-speed pulley on motor are new features.



ALL INSTRUMENTS ARE EQUIPPED WITH SIMPLE FOLDING STANDS

No. 405—DELUXE ARTISTS' VIBRAPHONE Tax Paid \$795.00B

3 octaves F to F range. Ends of frame 1¼" thick, finished in natural blonde wood with three polished tubes extending from top to bottom in modern design. Heavy 1½" aluminum bars, ranging from 2" to 1½" in width. Side rails polished aluminum. Polished resonators and damper pedal. Bodine silent motor. Mounted on 3" casters.—Measures 62" long, 34" high, 32" wide end, 15½" narrow end. Wt. 98 lbs.



• ROGERS • YARN-WOUND MALLETS

Professional quality — Rattan handles

- | | | | |
|----------------------------|-------|--------|---------------|
| No. 4797—Soft, yellow yarn | ----- | } Pair | \$3.75 |
| No. 4798—Medium, blue yarn | ----- | | |
| No. 4799—Hard, purple yarn | ----- | | |



• ROGERS • RUBBER MALLETS

Professional quality — Rattan handles

- | | | |
|-------------------------|--------|---------------|
| No. 4800—Mallet, 1 inch | } Pair | \$1.50 |
| Soft rubber ball ----- | | |
| No. 4802—Mallet, 1 inch | } Pair | \$1.50 |
| Hard rubber ball ----- | | |



• ELTON • MALLETS

- | | | | |
|--|-------|------|---------------|
| No. 265—Plastic handles with plastic balls | ----- | Pair | \$2.65 |
| No. 266—Plastic handles with rubber balls | ----- | Pair | 2.50 |

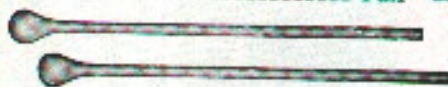

**NYLON ONE-PIECE
BELL-LYRA MALLETS**

Moulded from one-piece solid nylon plastic. New material not affected by heat or cold. No handle or ball to come loose. Gives clear, brilliant tone to Bell-Lyra.

- | | | | |
|------------|-------|------|---------------|
| No. 1740R— | ----- | Pair | \$3.00 |
|------------|-------|------|---------------|

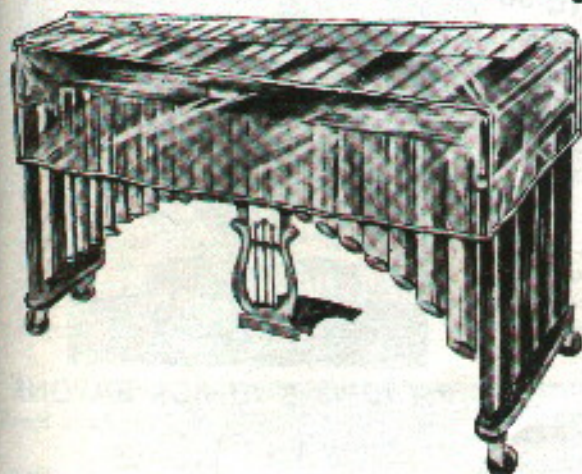

• KLEARSITE • COVERS

Made of transparent plastic film material, water-proof, dustproof, and stainproof. Damp cloth for instant cleaning. For window display or home use.

No.	Size	Each
171—Vibe	2 1/2 octave 28 1/2" x 40 1/2"	\$4.50
172—Marimba	2 1/2 octave 25 1/2" x 37 1/2"	4.50
173—Vibe	3 octave 30 " x 57 "	6.00
174—Marimba	4 octave 32 " x 71 1/4 "	7.95
175—Marimba	4 octave 33 " x 78 "	9.00



Al G. Wright
Director of Bands
Purdue University

**AL G. WRIGHT
BELL LYRA
MALLETS**

No. 4890
\$3.80
Pair

Guaranteed unbreakable balls. Semi-hard ribbed rubber hand-grips over shafts of 1/8" special alloy magnesium steel. Engineered for perfect balance and control to satisfy professional and student alike.

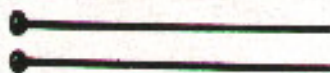

**• PERFECTION •
MALLETS**

- | | |
|-------------------|--------------|
| No. | Pair |
| 691—Maple balls | ----- \$0.75 |
| 692—Brass balls | ----- 1.50 |
| 694—Soft rubber | ----- 1.50 |
| 695—Hard 1" balls | ----- 1.50 |

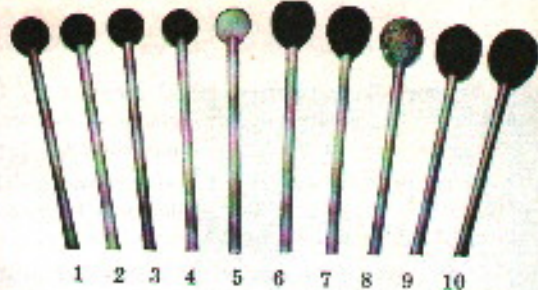

• MUSSER • MALLETS

Highest quality—genuine Rattan handles

- | | |
|--|--------------|
| No. | Pair |
| C-1—Yellow rubber | ----- \$2.20 |
| 1" Soft. Ideal for practice and 4 mallet work. | |
| C-2—Red rubber | ----- 2.20 |
| 1" Medium. For concert and recital | |
| C-3—Blue rubber | ----- 2.20 |
| 1" Half-hard. Loud Tone | |
| C-4—Gray rubber | ----- 2.20 |
| 1" Three-quarter hard. For Bells and Xylophone | |
| C-5—Plastic | ----- 2.50 |
| 1" Hard. For Xylophone and Bell Lyra | |
| C-6—Red yarn — woven | ----- 3.90 |
| Hard. Perfect for Vibe and Marimba 2, 3, and 4 mallet work | |
| C-7—Blue yarn — woven | ----- 3.90 |
| Semi-Hard. For Vibe, 2, 3, and 4 mallet work—Exclusive favorites | |
| C-8—Yellow yarn — woven | ----- 3.90 |
| Medium-soft. For Marimba 2, 3, and 4 mallet work. Most popular wound mallet | |
| C-9—Gray yarn — woven | ----- 4.25 |
| Soft. Recommended for Vibe and low register Marimba playing — Larger ball than C-8 | |
| C-10—Gray yarn — woven | ----- 5.00 |
| Larger ball than C-9 | |

• GREAT DANE • MALLETS

Unbreakable Fibre Glass Handles

GREAT DANE Vibraharp & Marimba Mallet Heads are wool yarn wound over patented grooved cores. Handles are custom made from fiber glass rod (not plastic) with contoured slender shanks for producing the proper resilient action needed for good playing technique. The overall mallet is expertly balanced by means of metal weights inserted in the head to meet the requirements of the professional touch.



**• GREAT DANE •
MARIMBA
MALLETS**
\$5.50 Pr.



**• GREAT DANE •
VIBRAHARP
MALLETS**
\$5.50 Pr.

- | | | |
|--|----------|---------------|
| No. 4836—Great Dane Professional Marimba Mallets. With larger heads and medium tension wound for mellow tone. Handles have longer shanks to render resilience necessary for vibrato playing. (Soft) grade is standard. Head color—Garnet red yarn. Overall length 14". | Per Pair | \$5.50 |
|--|----------|---------------|

Great Dane Professional Vibraharp Mallets. Heads are tightly wound to produce a sparkling, crispy tone quality. (Medium) hardness is standard. Overall length 14".

- | | |
|-------------------------|-----------------------|
| No. | Per Pair |
| 4837S—Soft, Grey Yarn | ----- } \$5.50 |
| 4837M—Medium, Blue Yarn | ----- } |
| 4837H—Hard, Black Yarn | ----- } |

FAMOUS • GROVER • "FLAME" BATONS

The "Flame" Baton is an original creation by Dotty Grover, former New York State Champion Twirler. Twirling of this model is growing in popularity not only among professionals, but especially among high school and college students, since it provides an exciting sport as well as an artistic accomplishment.

The ends are equipped with asbestos heads which are soaked in a mixture of kerosene and gasoline (or white gasoline alone) a few minutes before using. When ignited and twirled, the flame traces the outline of the movement in a spectacular manner. Special air vents are provided on the shafts for rapid cooling.

All Grover batons are meticulously balanced to suit the professional twirler. Shafts are DeLuxe chrome-plated. Detailed Instruction Sheet is furnished with each baton.

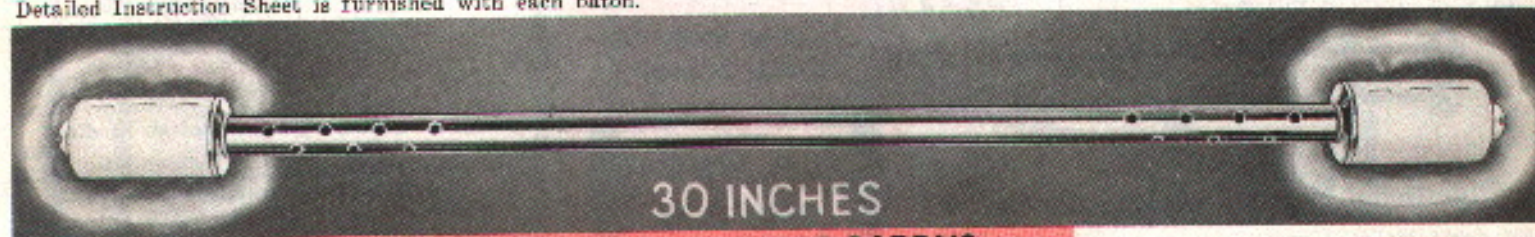

GROVER "FIREFLY" DEMOUNTABLE BATONS

"Duratest" 1/2" Steel Shaft, Chrome-Plated

No. 264—"Firefly" Model, 24 inch	\$9.75 Each
No. 266—"Firefly" Model, 26 inch	
No. 268—"Firefly" Model, 28 inch	
No. 270—"Firefly" Model, 30 inch	

GROVER "FIREFLY" DEMOUNTABLE HEADS

Light weight, nonbreakable, metal spool with asbestos wrapping. Threads into studs fastened into each end of shaft.

No. 332—Each Head	\$3.00;	Per Pair	\$6.00
-------------------	---------	----------	--------

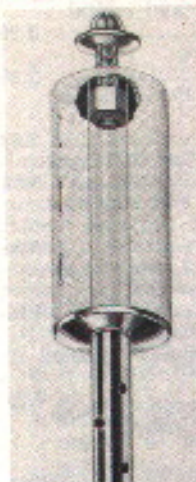

No. 332
Demountable
Head



GROVER FLAME BATON CARRYING CASE

Sturdy Metal Tube with Handle and Handy Cap as Snuffer to extinguish flame conveniently and safely. Fits all Flame Batons.

No. 272 — Baton Case	\$5.85
----------------------	---------------



• CROWN • JUNIOR BATONS

Nickel plated, unbalanced plain shaft. Small white pear-shaped ball.

	1/2" Shaft	Each
Length 18"	} \$1.75	
Length 20"		
Length 22"		
Length 24"	} \$1.35	
Length 28"		
Length 29"		

BATON TWIRLING BOOKS

Art of Baton Spinning, Vol. 1	\$1.50D
Art of Baton Spinning, Vol. 2	1.50D
5-Minute Baton Book	.35
How to Twirl a Baton, Lee	1.00B
Virginia Page Instructor	1.00

• KEN • JUNIOR ALL CHROME BATON

Especially designed for High Schools, Boy Scouts and younger organizations, using a smaller size Military baton. Metal ball — steel shaft, with built-in tapered tip, Gold cord, beautifully wrapped and tied.

No. 1538—38 inch length	} \$16.50 Each
No. 1540—40 inch length	



• KEN • SIGNAL BATONS REGULATION MILITARY MODEL

Large chrome plated ball, built in two pieces with removable top. Tapered "Non-Breakable" metal tip. Hardwood tapered shaft in choice of four colors. Heavy silk yellow cord and tassels. Individually packed. Please specify shaft color.

42 inch length	} \$24.00 Each	44 inch length
1442B—Jet Black		1444B—Jet Black
1442N—Navy Blue		1444N—Navy Blue
1442M—Mahogany		1444M—Mahogany
1442W—White		1444W—White

• KEN • BATON ENDS

New streamlined white rubber baton tips, 1/2" and heads to fit 9/16", 1/2" or 7/16" shafts.

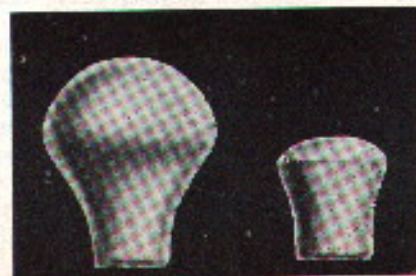

No.	Each
916B—Head for 9/16" shaft	\$0.75
916T—Tip for 9/16" shaft	.25
716B—Head for 7/16" shaft	.75
716T—Tip for 7/16" shaft	.25
212B—Head for 1/2" shaft	.75
212T—Tip for 1/2" shaft	.25
916S—Head and Tip 9/16" per set	1.00
716S—Head and Tip 7/16" per set	1.00
212S—Head and Tip 1/2" per set	1.00

FAMOUS • ROGERS • TWIRLING BATONS

"PROFESSIONAL" MODEL

Used and endorsed by Gloria Montowski, champion of numerous baton twirling contests.

Made of "Duratest" steel, known for durability and toughness. Each baton is carefully balanced—ideal for speed and precision performance. Well proportioned, streamlined white rubber ball. Extra long rubber tip provides better grip for execution of intricate exercises. Both ball and tip are securely mounted over flanges on shaft so twirler can feel secure in the knowledge that end will not come off while twirling. Circular dimples add sparkle and beauty to the shaft and provide better control. Triple chrome plated. Packaged in plastic bag designed for easy display.

	Professional Model BALLS & TIPS No. 4035 \$1.50 Per Set Newly designed, streamlined rubber ball and extra long tip to match. Extension flange on shaft will not allow them to come off.	
No. 4033-TIP Each50c		No. 4034-BALL Each ... \$1.00

7/16 inch Diameter

No. 4040—20 inch	} Each \$3.90
No. 4042—22 inch	
No. 4044—24 inch	
No. 4046—26 inch	
No. 4047—27 inch	
No. 4048—28 inch	

1/2 inch Diameter

No. 4020—20 inch	} Each \$3.90
No. 4022—22 inch	
No. 4024—24 inch	
No. 4026—26 inch	
No. 4028—28 inch	
No. 4030—30 inch	



"STANDARD" MODEL

A quality line of moderately priced batons, designed for volume sales. Strong steel shafts with hammered dimples for flash, sparkle and secure grip. Carefully balanced. White rubber ball with flat end and white rubber tip to match. Triple chrome plated. Individually packaged in plastic bag.

1/2 inch Diameter

No. 4071—18" Long	} Each \$2.95	No. 4074—24" Long
No. 4072—20" Long		No. 4075—26" Long
No. 4073—22" Long		No. 4076—28" Long

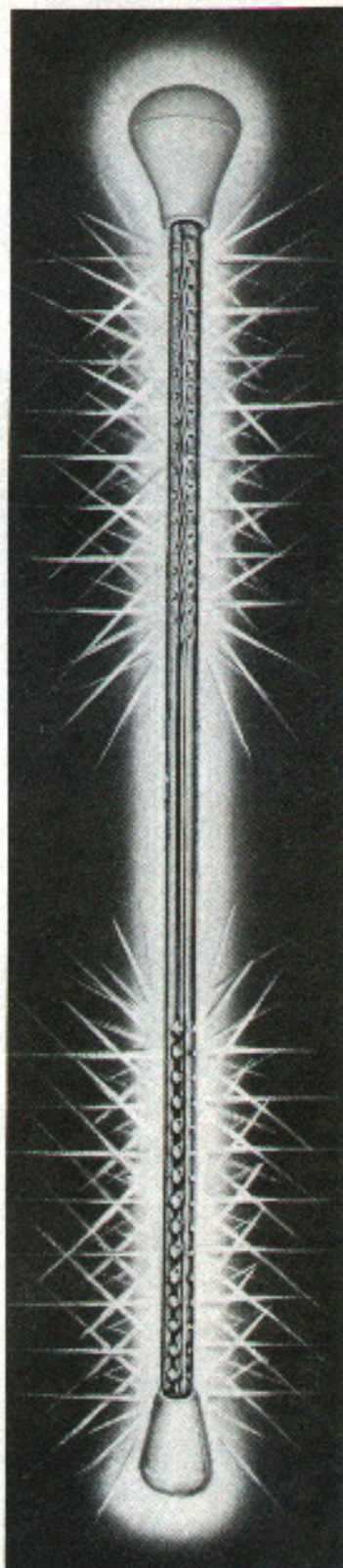

GLORIA MONTOWSKI

Ohio State Twirling Champion for 1960-61. Proud holder of 165 trophies and 135 medals. Recently declared "Major-ette Queen of St. Lawrence Seaway". A winner in the International Baton Twirling Competition. Also acclaimed for her spectacular twin fire baton performances. Gloria uses and recommends Rogers Twirling Batons.



• DUAL-GLOW • TWIRLING BATON

Center part is a brass tube, chromium plated that holds the batteries and lamp bulbs. At each end of the chromium plated tube is a 3/8 inch by 8 inch long unbreakable crystal shaft that glows with light by a right hand turn of either shaft. Weighs 15 ounces and is perfectly balanced. Supplied in tubular box.

No. 550-24—Baton, 24" Long	} Batteries NOT Included	\$13.50 Each
No. 550-26—Baton, 26" Long		
No. 550-28—Baton, 28" Long		

BATTERIES — 4 Required For 1 Baton

No. 4954—Batteries, Per Set of 4 Total \$0.96



• NICK MANLOFF • LIGHTED BATONS

Made of 3/8 inch steel shaft. Polished chrome plating. Perfectly balanced. Expanded on both ends to fit double pen light battery.

No. 798-22—Length 22"	} Each With 4 Globes \$10.80 Less Batteries
No. 798-24—Length 24"	
No. 798-26—Length 26"	
No. 798-28—Length 28"	
No. 798-30—Length 30"	

Important

Red, Blue, Green, Amber and Clear Globes available. Stock models supplied with 2 RED and 2 BLUE ends, unless otherwise requested.

No. 4954—Batteries, Per Set of 4 Total \$0.96

• CARPENTER • BATONS

CARPENTER FEATURES: Made of highest quality, dent-resistant steel, Jeweler's triple chrome plating. Exclusively designed Balls, Tips, and Shafts. Accurately balanced. Individually packaged in modern ptiofilm bag.

• ROUND DIMPLE • HAMMERED SHAFT BATONS

Dimple Hammered Split Shaft 1/2" Diameter		
SS22—22" long— 1/2" shaft	} Each \$3.90	
SS24—24" long— 1/2" shaft		
SS26—26" long— 1/2" shaft		
SS28—28" long— 1/2" shaft		

• BLUE RIBBON • SILVER STREAK BATONS

Plain Shaft—1/2" Diameter Scientifically designed 1/2" model. Fine Carpenter work- manship, triple chrome plating, white shock absorbing ends.		
SA22—22" long	} Each \$3.30	
SA26—26" long		
SA28—28" long		

• ROUND DIMPLE • HAMMERED SHAFT BATONS

Dimple Hammered Split Shaft 7/16" Diameter		
716S18—18" long	} Each \$3.90	
716S20—20" long		
716S22—22" long		
716S24—24" long		
716S26—26" long		

• DIAMOND DIMPLE • HAMMERED SHAFT

Dimpled Split Shaft— 1/2" Diameter		
SH22—22" long	} Each \$3.90	
SH24—24" long		
SH26—26" long		
SH28—28" long		

• ECONOMY • BALANCED MODEL

Inexpensive practice Batons, with white rubber ends and chromium plated smooth plain shaft. Perfectly balanced 1/2" model.		
Smooth Shaft—1/2" Diameter		
SX20—20" long	} Each \$2.60	
SX22—22" long		
SX24—24" long		
SX26—26" long		

• BLUE RIBBON • SILVER STREAK PLAIN BATONS

Plain Shaft — 7/16" Diameter		
716A18—18" long	} Each \$3.90	
716A20—20" long		
716A22—22" long		
716A24—24" long		
716A26—26" long		

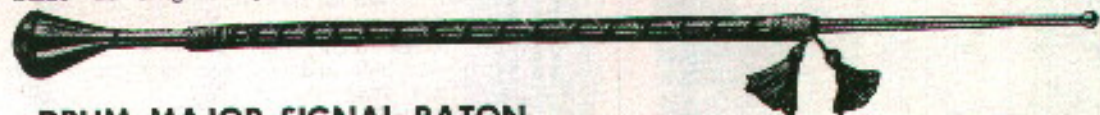

DRUM MAJOR SIGNAL BATON

All steel, chromed, including ball and tip. Rich looking cord and tassel.

M38—Junior 3/4" dia. 38" long	\$15.50
Each	
M45—Senior 3/4" dia. 45" long	\$15.75
Each	

• CARPENTER •

REVOLVING BATON STAND

No. B-018—Carnival Baton Display Kith with stand and 18 assorted batons **\$70.20**

Revolving stand constructed of finished plywood and tubular steel. Stand holds 18 batons and regularly lists at \$18.00. Included FREE with assortment of batons as listed below.

	Each
1 pc. 716S22—7/16" shaft, round dimple hammered	\$3.90
3 pcs. 716S24—7/16" shaft, round dimple hammered	3.90
3 pcs. 716S26—7/16" shaft, round dimple hammered	3.90
2 pcs. 716S28—7/16" shaft, round dimple hammered	3.90
1 pc. SS22—1/2" shaft, round dimple hammered	3.90
3 pcs. SS24—1/2" shaft, round dimple hammered	3.90
3 pcs. SS26—1/2" shaft, round dimple hammered	3.90
2 pcs. SS28—1/2" shaft, round dimple hammered	3.90

Total Retail Value **\$70.20**
Revolving Stand 18.00
Kit Retail Value **\$88.20**

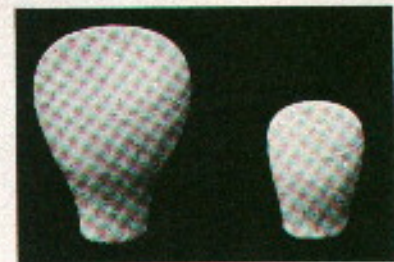

• CARPENTER •

"SHOCK ABSORBER" BATON ENDS

No.	Each
4916—Ball for 9/16" shaft	\$0.75
4917—Tip for 9/16" shaft	.40
4964—Ball for 7/16" shaft	.75
4965—Tip for 7/16" shaft	.40
4905—Ball for 1/2" shaft	.75
4906—Tip for 1/2" shaft	.40
4918—Ball and Tip 9/16"—per set	1.00
4966—Ball and Tip 7/16"—per set	1.00
4907—Ball and Tip 1/2"—per set	1.00

• KEN • BATON BALANCING WEIGHTS

No. 916W— 9/16" Weight	} 30¢ Each
No. 212W— 1/2" Weight	
No. 716W— 7/16" Weight	



• KEN • BATON CORDS with TASSELS

No. 1541—Gold	} Each \$2.25
No. 1542—White	
No. 1543—Blue	
No. 1544—Red	

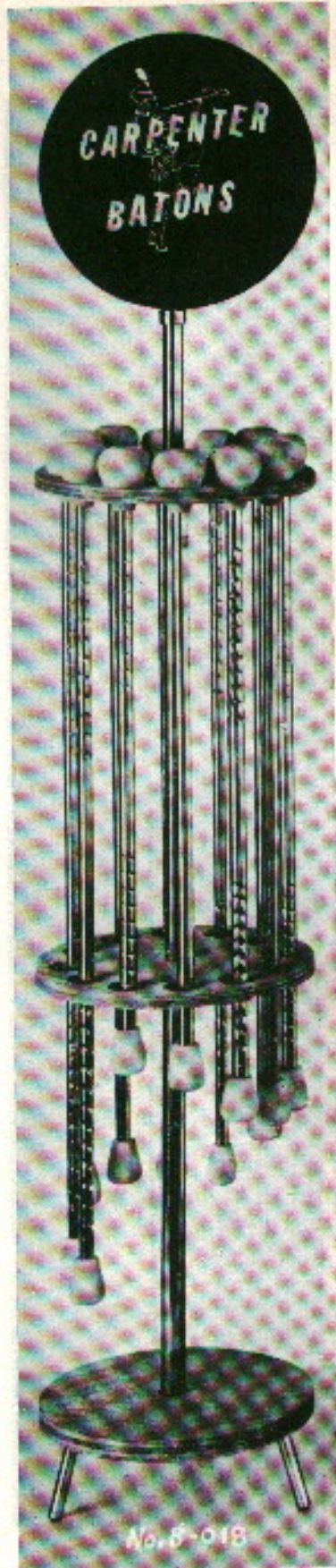

No. B-018

• KEN • KROME DIMPLE BATONS

KEN FEATURES: All steel "can't-slip" balancers, perfectly center balanced. Finest "Hard-Chrome" triple process plating. Most modern, practical head and tip design. Guaranteed for one year under normal use.

Ken Krome 7/16 INCH	718D—18" long	} \$3.75 Each
	720D—20" long	
	722D—22" long	
	724D—24" long	
	726D—26" long	
728D—28" long		

Ken Krome 1/2 INCH	220D—20" long	} \$3.75 Each
	222D—22" long	
	224D—24" long	
	226D—26" long	
	228D—28" long	

MUSIC FOR THE DRUMMER

3 R's for Snare Drum, Book 1	\$1.25D
3 R's for Snare Drum, Book 2	1.25D
3 Star Drum Method, Rogers	.50B
6 Unaccompanied Solos	1.00D
7 Rudiments, Tietman	.85D
14 Modern Contest Solos for Snare Drum by John S. Pratt	1.50D
20 Studies In Swing	1.00D
40 New Street Cadences	.75D
56 Progressive Duets	.75D
110 Progressive Etudes, Book 1	1.25D
110 Progressive Etudes, Book 2	1.25D
128 Rudimental Street Beats, Modern Rolloffs and Modern March Beats, by John S. Pratt	1.50D
150 Progressive Drum Rhythms	.50D
312 Modern Drum Studies, Sternberg	2.50B
ABC GUIDE TO DRUMMING, ULANO	1.50D
Advanced Technique, Chapin	2.50F

Bower Method	2.25F
Breeze-Easy Method, Book 1	1.00D
Breeze-Easy Method, Book 2	1.00D
Suggert Method, Book 1	1.25D
Suggert Method, Book 2	1.25D
CHAPIN, ADVANCED TECHNIQUE	2.50F



**COZY COLE
WM. V. KESSLER
COMPLETE MODERN
DRUM METHOD
\$3.50D**



**COZY COLE
MODERN ORCHESTRA
DRUM TECHNIQUE**

A study of rudimental drum techniques and their application to modern orchestra rhythms. Including drum solos as played by COZY COLE based on the following popular standard songs: Star Dust; The Sheik of Araby; Lonesome and Sorry; Bugle Call Rag; Dinah; Who's Sorry Now.

\$1.25D



**DESIGN FOR THE DRUM SET
By Don Lamond, Henry Adler**

A series of exercises designed to enable the modern drummer to acquire greater facility on the drum set.

\$2.50B



**DEVELOPING "DRUM BREAKS"
AND "FILL-INS"**

by **Sonny Igoe and Henry Adler**

A book of modern drum figures broken down to their basic or rudimental forms and then built up "step by step" in a series of exercises that enables the drummer to play drum breaks and fill-ins utilizing the entire drum set, in as easy swinging manner.

\$1.50B

Dodge Drum Chart	.75F
Drum and Bell Lyre Interludes	.75F
Drum Cadences	.60D
Drum Class Method, Vol. 1, Heim	1.25D
Drum Class Method, Vol. 2, Heim	1.25D
Drumcraft	1.50D
Drum Ensembles For All Occasions	1.50D
Drum Rhythm Speller	.85D

DRUM RHYTHMS

Features: All Dance Rhythms; Latin American Rhythms; Drum Duets; Studies In Various Time Signatures; Reading Technique; Coordination; The Secret Rhythm Tricks Of The World's Outstanding Drummers, Gene Krupa — Cozy Cole — Wm. V. Kessler.

\$2.00D

Drum Solos and Fill-Ins, Ted Reed	2.00D
Drum Warm-Ups	.90D
Drummer's Hand Study Guide	1.00D
Drummer's Heritage	3.00F
Drummer's Roll Study Guide	1.50D
Drummer's Rudimental Guide	1.50D
Drumming In Five Easy Steps	1.50D
Drumming The Latin-American Way	1.25D

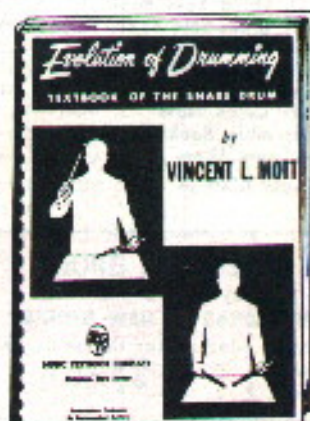

EVOLUTION OF DRUMMING

By **Vincent L. Mott**

The purpose of this book is to present the rudiments of drumming concisely, thoroughly and effectively. The guidance presented herein will lead to a surprisingly high degree of proficiency in less time and with less effort. The value in this book lies in a new, systematic order of 26 rudiments of drumming. Complete from "A to Z".

\$3.50D



**NEW — ORIGINAL — AMAZING
THE CHARLES ALDEN
DRUM-O-WHEEL**

Practice chart for drummers.

Over 65,000 combinations of hand-to-hand sticking and accenting exercises for the practicing drummer, to develop **SPEED — POWER — DEXTERITY — CONTROL — COORDINATION**. A colorful book-size chart, backed by four revolving discs. Each turn of a wheel creates a new and interesting combination.

\$2.00 each

All American Drummer, Phil Grant	1.00D
America's Greatest Drum Stylist	1.00D
All Melody Method, Book 1	.85D
All Melody Method, Book 2	1.00D
Ancient Rudimental Snare and Bass Drum Solos, by John S. Pratt	1.00D
Art of Drumming, Burns Moore	1.00B
BASS BOPS, ULANO	1.50D



**LOUIS BELLSON
"THE MUSICAL DRUMMER"**

A basic method for concert, band, orchestra, and dance drumming.

Volume 1	\$3.50D
Volume 2	3.50D
5 Concert Drum Solos and 4 Duets	1.00D
Long Roll Studies	.60D
Paradiddle Studies	.60D

EASY STEPS TO DRUMMING	1.50D
Elementary Dance Drumming, Ludwig	1.00B
Encyclopedia of Drumming	2.50D
FIRST DUET BOOK FOR 2 DRUMS	.50D
Carl Fischer Tutor	2.00F
Foot Development, Ullano	1.50D
Futuristic Drum Solos	1.50D
GARDNER, FIRST YEAR DRUMMER	.75F
Gardner, Modern Method, Part 1	3.00F
Gardner, Modern Method, Complete	7.50F
Gardner, Progressive Method, Book 1	1.00F
Gardner, Progressive Method, Book 2	1.00F
Gardner, Progressive Method, Book 3	1.25F
Gardner, Progressive Method, Book 4	1.00F
Goldenberg Modern Method	4.00F



HAPPY DRUMMING WITH A BEAT
BY CHARLES "CHUCK" SIMONS

17 Original Drum Solos with 26 Standard Drum Rudiments. A Collection of Rudimental drum solos composed to provide the Band Director with an all-purpose material. A variety of progressively graded solos specifically designed to meet the needs of the school drummer. The professional will also find this book interesting reading and a challenge to his technique.

\$2.50D



Haskell Harr Drum Solo Book	.50
Haskell Harr Drum Solo Book, Piano Part	.75
Haskell Harr Drum Method, Book 1	1.50
Haskell Harr Drum Method, Book 2	1.50
Haskell Harr Simplified Drum Solos	.50
Haskell Harr Large Note Ensemble Book	1.00
Here's The Snare Drum	1.50D
Imperial Drum Method	1.50D

HERE'S THE DRUM

by Emil Shelle

NEW IDEAS — NEW STUDIES

A Complete Method for the Snare Drum.

Book 1	\$1.50 B
Book 2	each

SHELLY MANNE DRUM FOLIO NO. 1

Original drum parts as recorded by Shelly Manne, together with his actual recordings of compositions by Jimmy Giuffre, Bob Cooper and Jack Montrose.

45 RPM Record and Book

\$2.50D



INTRODUCTION TO THE DRUM SET

By Charles Perry

Instructions for Bass Drum; Hi Hat; Snare Drum; Brush Beats; Elementary Drum Breaks.

Volume 1—Elementary	\$1.50B
Volume 2—Intermediate	2.50B



GENE KRUPA DRUM METHOD	3.00D
Gene Krupa Science of Drumming, Book 1	1.50D
Gene Krupa Science of Drumming, Book 2	1.50D
LANGLEY DRUM TUTOR	2.00F
Latin-American Rhythms, Ralo	1.00D
Latin Rhythms, Ted Reed	1.50D
Little Champ Drum Solos	1.50D
Ludwig Collection of Solos	1.00B
Ludwig Drum Instructor	1.00B
Ludwig, Elementary Dance Drumming	1.00B
Ludwig Swing Drumming	1.00B
SHELLEY MANNE FOLIO, No. 1	2.50D
Melody Way To Syncopation	1.00D
Military Drum Beats	1.00D
Mitchell's Drum Solos	1.00F

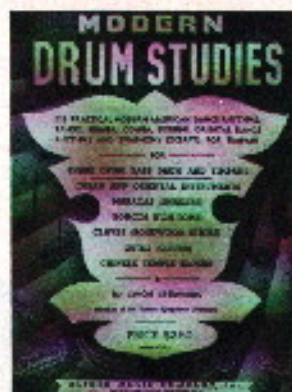

MODERN DRUM STUDIES

by Simon Sternburg

312 practical modern american dance rhythms, tango, rumba, conga, beguine, oriental dance rhythms and symphony excerpts for tympani.

\$2.50B

Morales Latin-American Rhythms	3.00B
Maeller Book	1.00B
Musical Drummer, Bollison, Volume 1	2.50D
Musical Drummer, Bollison, Volume 2	2.50D
N. A. R. D. Drum Solos	1.00B
NATIONAL SELF-TEACHER	4.00B
PACE, SUPPLEMENTARY STUDY BOOK	1.25
Pace, Variations of Drumming	2.75
Paramount Method	.75B



PRACTICAL METHOD OF DEVELOPING FINGER CONTROL FOR DRUMMERS

By ROY BURNES & LEWIS MALIN

Edited by Henry Adler. Contents:

- Part 1—No Bounce Studies
- Part 2—Bounce Studies
- Part 3—Accent Studies
- Part 4—Solo Studies

\$2.00B



PAUL PRICE SNARE DRUM METHOD

A logical musical approach to teaching the snare drum.

\$3.50D



SUPPLEMENTARY DRUM STUDY

by Ralph C. Pace

Stick Control Reading; Coordination; Accentuation; Rolls; Rudiments; Variations of Rudiments; Solos.

\$1.25

Podemski's Drum Method	3.00D
Practical Guide To The Working Drummer	1.50D
Prescott, The Snare Drum	.75F
Prescott Outline Part I	.60F
Professional Drum Studies, Wetting	2.00D
REVIEWING THE RUDIMENTS	1.00D
Rhythmic Foundation Through Drumming	1.00F
Rogers' 3 Star Method	.50B
The Roll, Shelle	1.50D
Rollison Method	1.25D
Rominger Method	1.50D

MUSIC FOR XYLOPHONE - MARIMBA - VIBES - TYMPANI

XYLOPHONE — MARIMBA

Methods — Studies — Collections

16 Smart Studies, Hufnagle	\$1.50D
19 Swing Etudes, Paisner	1.00D
30 Studies In Swing, Paisner	1.25D
40 Rhythm Etudes	1.00D
78 Solos for Marimba, Book 1, Jolliff	1.00D
78 Solos for Marimba, Book 2, Jolliff	1.00D
AD LIB, BUGS BOWER	1.50D
All American Rhythm Courses, Norvo	1.00D
Artistry Of Shorty Rogers	1.50D
Atonal Duets, McKusick	1.50D
Advanced Dance Studies, Colin	1.50D
BEST OF TONY SCOTT	1.50D
Black Chords	1.50D
Blues 'N Rhythm	1.50D
Bop, Bugs Bower	1.50D
Bop Combos, Bugs Bower	1.50D
Bop Duets, Bugs Bower	1.50D
Bower System	2.50F
Buggert Method	1.25D
CHORDS, VOLUME 1, BUGS BOWER	1.50D
Chord Progressions, Volume 2, Bugs Bower	1.50D
Classics In Jazz	1.50D
Cool Sounds, Miles Davis, Book 1	1.50D
Cool Sounds, Miles Davis, Book 2	1.50D
DORN—XYLOPHONE METHOD	1.50D
Descriptive Duets, Vol. 1	1.50D
Descriptive Duets, Vol. 2	1.50D
Develop Sight Reading, Vol. 1	1.50D
Develop Sight Reading, Vol. 2	1.50D



GEORGE DEVENS' LESSON PLAN FOR MALLET INSTRUMENTS

A Musical Approach to Technique for Vibes, Marimba and Xylophone.

\$3.00B

Dizzy Blows Kerouac	1.50D
Don Elliot Blows Up A Storm	1.50D
Duets (Advanced), Vol. 1, Colin	1.50D
Duets (Advanced), Vol. 2, Colin	1.50D
Duets Just Kiddin' Around	1.50D
EAR TRAINING AND SIGHT SINGING	1.50D
East Coast Jazz Scene	1.50D
Etudes Moderne, Colin	1.50D
GOLDENBERG—MODERN SCHOOL FOR XYLOPHONE	4.00F
Great Jazz Lines	1.50D
Howard Greene Method	.85D
George Hamilton Green's Solos	1.00D
LIONEL HAMPTON'S VIBRAPHONE FOLIO	2.00D
Lionel Hampton's Vibraphone Method	2.00D
Harlem Uptown Jazz	1.50D
Haskell Harr Marimba Method	1.00D
Haskell Harr Marimba Solos	1.50D
Hiraoka Album of 11 Compositions	1.00D
JAZZ DUETS, VOLUME 1	1.50D
Jazz Duets, Volume 2	1.50D
Jazz Originals, McKusick	1.50D
Jazz Phonetics	1.50D
Jazz Phrasos	1.50D
Jazz Themes	1.50D
Jazz Workshop	1.50D
KEYBOARD CHORDS	1.50D
Keyboard Harmony	1.25D

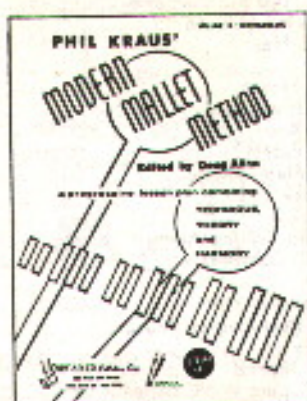

PHIL KRAUS MODERN MALLET METHOD

The latest comprehensive method for mallets written by the famous New York percussionist, mallet instrumentalist and teacher. A must for professional and student.

Volume 1—Elementary	\$3.00B
Volume 2—Intermediate	5.00B
Volume 3—Advanced	5.00B

MALLET CONTROL	3.00D
Marimba Ensemble Fallo	1.00D
Marimba Solo Classics	1.00F
Mat Mathews Swings	1.50D
Milt Meets Oscar	1.50D
Modern Art Of Jazz	1.50D
Modern Hot Xylophone Solos No. 1	1.00D
Modern Hot Xylophone Solos No. 2	1.00D
Modern Marimba Method	1.00F
Modern School For Xylophone—Goldenberg	4.00F
Modern Vibraphone Method	1.00F
Music For Marimba, Vol. 1	1.25D
Music For Marimba, Vol. 2	1.25D
Music For Marimba, Vol. 3	1.25D
Music Of Chopin, Musser	3.50D

NEW SOUNDS	1.50D
New Sounds In Technique	1.50D

PARES SCALES	1.00D
Peterson's Studies	1.00D
Playing With Chords	1.00D

RECORDED SOLOS	1.50D
Rhythms, Vol. 1, Colin	1.50D
Rhythms, Vol. 2, Colin	1.50D
Rubank Elementary Method	1.00B
Rock 'N Roll, Bugs Bower	1.50D

SOLOIST FOLIO	1.50D
Sacred Time Around The World	1.25D
Solos Of The Immortals	1.50D
Stone—Mallet Control	3.00D
Streamlined Etudes	1.25D
Stralain—Method Of Velocity	2.00F

TONY SCOTT WAILS	1.50D
Tune A Day Xylophone	1.00F
Tune A Day Piano Accompaniment Book	1.00F

WARNER'S VERY EASY METHOD	.40D
West Coast Jazz	1.25F

XYLOPHONE TECHNIQUE, HARRY BREUER	1.00B
-----------------------------------	-------

YARDBIRD ORIGINALS, PARKER	1.25D
35 Original Studies	1.25D
83 Famous Songs	1.50D

BILLY DORN'S XYLOPHONE SOLOS

Blockhead Polka	\$1.25B
Chasin' Gary	1.25B
Dixie Sticks	1.25B
Ethel's Favorite	1.25B
Just A Little Of This And A Bit Of That	1.25B
Mallet Melody	1.25B
Melody Mazurka	1.25B
Shufflin' On The Sand	1.25B
Step After Step	1.25B
Trippin' and Skiddin'	1.25B



FLORENCE SCHAEFER'S XYLOPHONE METHOD

Basic instruction designed for the beginner. Contains Music Theory; Mallet Fundamentals; Marimba and Xylophone Facts; 175 Short Exercises; 52 Songs; 7 Music Quizzes.

\$2.00B

TYMPANI METHODS AND COLLECTIONS

SAUL GOODMAN Modern Method for TYMPANI Each \$5.00F
Including four major sections in the one book.

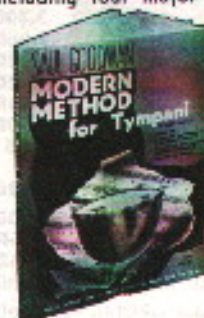

1. Fundamentals
2. Exercises for the Development of Technique on two drums
3. Three and four drum technique (inc. Pedal Tympani)
4. Repertoire for Tympani

Saul Goodman has packed between these covers a veritable lifetime of study and experience to develop the young musician to the point of sincere appreciation for his instruments and a working knowledge of the outstanding repertoire examples.

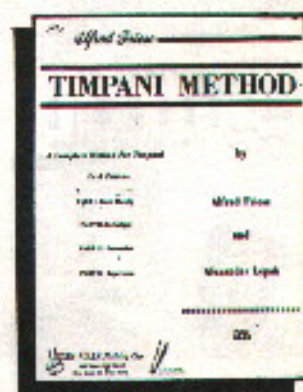

ALFRED FRIESE

• TIMPANI METHOD •

A complete method for Tympani in 4 parts:

- Part 1—Basic Theory
- Part 2—Technique
- Part 3—Intonation
- Part 4—Repertoire

\$5.00B

Belwin Tympani Method	\$1.50D
Bower Method	2.00F
Gardner Method	3.00F
Harr Method	1.00D
Rubank Elementary Method	1.00B
Tympani Passages Vol. 1	1.00D
Tympani Passages Vol. 2	1.00D
Tympani Passages Vol. 3	1.00D

XYLOPHONE SOLOS

Adagio (from Moonlight Sonata)	.50D
Ah, So Pure, Bethancourt	.60D
Ah, Sweet Mystery Of Life	.75D
Allegro, Breuer	.75D
An Indian Story, Green	1.00F
Andalucia, Lecuona	.75D
Argentinita, Breuer	.60D
Ave Maria, Schubert-Edwards	.50D
Barcarole, Wittman-Bugyort	.75F
Bit O' Rhythm, Breuer	.75D
Black And White Rag	.75D
Blue Room	.75D
Blue Tid Bit, Breuer	.75D
Breakfast Breakdown, Norvo	.75D
Brownies, Leoni-Glenn	.50D
Canadian Capers	1.00D
Caprice Valsant, Green	1.00F
Chiu, Chiu, Breuer	.75D
El Choclo, Breuer	.60D
Chokin' The Bell, Breuer	.75D
Chopsticks, Owen	.75F
Cindy	.60D
La Cinquantaine	.60D
Coronation March	.60D
La Comparsita, Breuer	.60D
Dance Of The Octopus, Norvo	.75D
Dance Of The Queen Swan	.75D
Dance Macabre, Breuer	1.00D
Dazy Fingers, Herman	.60D
Eighteenth Century Theme	.60D
Elegie, Peterson	.60D
Elegantz, Peterson	.60D
Etude In Ab, Musser	1.25D
Fairy Pipers, Brewer-Glenn	.50D
Fantasy On St. Patrick's Day, Musser	1.00D
Fantasy On Yankee Doodle, Musser	1.00D
Gavotte In D, Gossec	.60D
Gitanerias, Lecuona-Peterson	.75D
Glow-Worm, Quick	.75D
La Gelondrina, Bethancourt	.50D
Grasshoppers' Dance	.60D
Gypsy Dance, Breuer	.75D
Happy Hammers, Breuer	.75D
Hole In The Wall, Norvo	.75D
Hora Staccato, Heifetz-Goldenberg	.80F
Imitation, Breuer	.50D
Jalousie	.75D
Jolly Caballero	.75D
Kindlin' Wood	.75D
Knocking On Wood, Norvo	.75D
Lady Of Spain	.75D
Largo, Dvorak-Quick	.50D
Malaguena, Lecuona	.75D
March Militaire, Schubert-Quick	.60D
March Of The Dwarfs, Peterson	.60D
Marimba Capers	.75D
Mighty Lak' A Rose	.75D
Minuet In G, No. 2, Beethoven-Wallace	.50F
Minute Waltz, Chopin-Breuer	.60D
Morris Dance, Breuer	.60D
Nine Tango, Bethancourt	.50D
Nona But The Lonely Heart, Bethancourt	.60D
Polichinella, Serenade, Kreisler-Green	.80F
Prelude, Op. 11, No. 3, Musser	1.00D
Raymond Overture	1.00D
Repass Band, Herman	.60D
Rondo Brilliant	.75D
Santa Lucia, Harr	.75D
Scarf Dance, Quick	.60D
Schon Rosmarin, Kreisler-Queen	1.25F
Seguidilla, Peterson	.60D
Serenade, Peterson	.60D
The Secret	.60F
Spanish Dance No. 2, Musser	.60D
Spanish Dance No. 5, Musser	.60D
Spanish Waltz, Green	1.00F
Spiritual Fantasia, Quick	.60D
Star Dust, Herman	.60D
Sylvia, Delibes-Edwards	.60D
Tea For Two	.75D
Tulip Polka, Breuer	.75D
Valse Bloue, Edwards	.60D
Valse Mirage, Herman	.60D
Zampa Overture	1.00D

TIMPANI SOLOS

4 Graded Solos, McKenzie	1.50D
Fantasy-Scherzo, Noak	3.50D
Solo No. 1, Paul Price	.40D
Solo No. 2, Paul Price	.40D
Solo No. 3, Paul Price	.40D
Andante	.75D
Suite for Timpani	1.00D
Classical Timpani March	1.00D
Dance Primitive	1.25D
Toccata for Marimba, Diemar	1.00D
6 Advanced Exercises, Paul Price	.75D

BOOKS FOR THE LATIN-AMERICAN DRUMMER



LATIN-AMERICAN RHYTHM • INSTRUMENTS and HOW TO PLAY THEM

By Humberto Morales & Henry Adler
How to Play Timbales, Maracas, Clavas, Congo Drum, Bongos, Jew-Bone.

\$3.00 B

Castanet Playing	.50B
How To Arrange Latin-American Instruments	1.50D
How To Play Bongos	1.00
How To Play Bongos - Congo Drums - Timbales, Maracas	1.95D
How To Play Congo Drums	1.00D
How To Play Maracas	1.00D
How To Play Timbales	1.00D

BRAZILIAN RHYTHMS

A tutor for Latin-American instruments and rhythms. This method contains only the best known Brazilian dance rhythms and the way they are popularly performed by orchestras...

.85 D

BONGOS and HOW TO PLAY THEM

A simplified and illustrated method for the Bongos by Wm. V. Kessler.

\$1.00 D



LET'S ALL PLAY BONGOS

\$1.00 D

BONGO DRUM INSTRUCTION

by William Loughborough
12" LP record, Complete instruction for Bongo playing: Two, Three and Four beat exercises; Two Octave tympani demonstration; Bass marimba demonstration.

\$5.95 D

No. FI 8320—Bongo Record



45 BASIC BONGO BEATS

\$1.00 D

Each

LATIN-AMERICAN DRUM RHYTHMS
Complete with studies and examples by Le Roy S. Weill.
\$1.25 D

BONGOS MADE EASY

by Chico Arnez

\$1.00

BATON TWIRLING BOOKS

Art of Baton Spinning: Volume 1—Elementary	1.75F
Volume 2—Intermediate	1.75F
Art of Gun Spinning, Vol. 1	1.00F
Art of Gun Spinning, Vol. 2	1.00F
Baton Twirling Series, Vol. 1	1.00F
Baton Twirling Series, Vol. 2	1.00F
Baton Twirling Series, Vol. 3: Part 1	.50F
Part 2	.50F
Baton Twirling Series, Vol. 4	1.00F
Twirl-A-Flag Manual	1.50F
Virginia Page Baton Book	1.25
WFL Baton Twirling	1.00B

MARCHING MANEUVER SERIES

\$1.00 F each

Vol. 1—"Formations—Entrances"—Hindsley	
Vol. 2—"Practical Stunts"—Smith	
Vol. 3—"Grooming the Band for Contest"—Bennett	
Vol. 4—"Required and Special Maneuvers"—Bennett	
Vol. 5—"Street Routines"—Bennett	
Vol. 6—"Field Routines"—Bennett	
Vol. 7—"New and Novel Formations"—Bennett-Whitfield	
Vol. 8—"Novel Drills and Formations"—(Basketball) Hackney-McCord	
Vol. 9—"In and Out of 26 Letter Formations"—Bennett	
Vol. 10—"Parade Stunts"—Hackney-Emerson	

THE ART OF DRUM MAJORING

A complete manual for the DRUM MAJOR and DRUM MAJORETTE by Bob Roberts and Charles Scott.

\$2.00 D

FIFE AND DRUM CORPS BUILDER — BOOK 1

An Elementary Method for Individual or Class or Full Corps Instruction by Acton Ostling.

Fife	.75D
Snare Drum	.75D
Bass Drum	.75D
Conductor-Manual	1.50D

FIFE AND DRUM CORPS BUILDER — BOOK 2

Fife	.75D
Snare Drum	.75D
Bass Drum	.75D
Conductor-Manual	1.50D
WFL Drum Corps Manual	1.00

RECORDS FOR THE PERCUSSIONISTS



THEORY AND PRACTICE OF MODERN JAZZ DRUMMING

2 LP RECORDS containing the complete Volume 1 of JIM CHAPIN'S ADVANCE TECHNIQUES OF DRUMMING. Each exercise of the book is done two to three times, using Bass Violin Solosists Wilber Ware and Aaron Bell to play the Melodic Exercises for the home drummer to practice against, besides having Jim Chapin demonstrate each exercise at different tempi.

No. MMO 4001—Theory and Practice of Modern Jazz Drumming. 2 LP

Record set. Retail Price \$7.96

\$8.25 B
List Price



FUN WITH DRUM STICKS (Drums Do-It-Yourself)

Play with the Jim Chapin Sextet. Everyone Loves to Drum. Deluxe box with a pair of drum sticks. Explains: How to hold them. What to hit; Complete with Jazz; Go to It. Contents: Pink Ice; Cottontail; Say What?; Like Help; I May Be Wrong; I'll Take Romance; The Lady Is A Tramp. Retail Price \$3.98.

MMO 125 Record List Price **\$4.12 B**



FOR DRUMMERS ONLY! JAZZ BAND MINUS ONE DRUMMER

Conceived and Arranged by JIM CHAPIN and BOB WILBER

Contents: Same as "SKIN TIGHT" with Drum parts missing.

Featuring: Bob Wilber—Tenor Sax; Phil Woods—Alto Sax; George Dorsey—Alto Sax; Urbie Green—Trombone; Jim Nottingham—Trumpet; Hank Jones—Piano; Wilbur Ware—Bass; Jim Chapin—Drums.

Retail Price \$6.95 List Price **\$7.25 B**
MMO 4002—For Drummers Only



PHIL KRAUS Presents "CONFLICT"

Contents: Conflict; First Movement, Second Movement; Third Movement; Three Brothers; Kriss-Kraus; Prelude And Fugue; Nonet; Three Dances. Retail Price \$4.98

No. CR 4004

\$5.15 B



THE JIM CHAPIN SEXTET

Contents: In A Little Spanish Town; Blue Lou; Sonny's Tune; The Goof And I; Charokey; Little Marty; Jazz Crossroads; Woodlore. Featuring: Phil Woods—Alto Sax; Billy Byars—Trombone; Don Stratton—Trumpet; Sonny Truitt—Piano; Chuck Andrus—Bass; Jim Chapin—Drums.

Retail Price \$4.98 List Price **\$5.15 B**
CJ-6—Jim Chapin Sextet Record

GRADED DRUM SOLOS ON RECORDS

with piano accompaniment

Records are 7 inch LP-33 1/3. Each record has 6 solos in 3 or 4 grade levels, easy to medium. Contents: Calssons Go Rolling Along; Marine's Hymn; When Johnny Comes Marching Home; American Patrol; Comrades March; Drum-nastics.

\$1.00 F

(above solos also available in sheet music)

BLUE DRUMS

Jazz trio minus a drummer. Ten original blues by Mal Waldron, performed by Mal at the piano and jazz bassist Wendell Marshall. Delightful practice material for the modern drummer. The blues in a cross-section of every style likely to be encountered in jazz.

Retail Price \$6.95 List Price **\$7.15 B**
MMO 4005—Blue Drums



YOU'RE ON DRUMS

Recorded by the JIM CHAPIN SEXTET featuring Bob Wilber; Doc Severenson; Eddie Bert; Sonny Truitt; Emil Powell and Jim Chapin. On side A — YOU ARE THE DRUMMER. On side B — Jim Chapin plays the same arrangements. A 30 page book of parts is included with Jim's exact fills and solos plus simpler supplementary parts. Contents: Summit Stomp; Sonny's Minor Interlude; Carny Days; Miss Pretty; Blue Throats. Retail Price \$5.95.

No. BDE-1002 List Price **\$6.15 B**



WARREN BENSON Presents "PERCUSSION"

Featuring the Ithaca Percussion Ensemble
Contents: Fanfare For Percussion Instruments; Afro-Fuga; Overture De Ballet; Danse Du Diable; Introduction And Fugue; Three Short Pieces; Rondino For Percussion Quartet; Variations On A Handmade Theme For Eight Hand Clappers. Retail Price \$4.98

No. CR 4016 List Price **\$5.15 B**

PERSUASIVE PERCUSSION

Recorded by TERRY SNYDER and THE ALL STARS featuring Tony Mottola; Willie Rodriguez; Dick Hyman; Jack Lesberg; Teddy Sommer; Artie Merotti; Stanley Webb; Dominic Cortese.

Contents: I'm In The Mood For Love; Whatever Lola Wants; Misirlou; I Surrender Dear; Orphans In The Moonlight; I Love Paris; My Heart Belongs To Daddy; Tebu; The Breeze And I; Aloha Oe; Japanese Sandman; Love Is A Many-Splendored Thing. Retail Price \$4.98

No. RS 33-800 Record LP List Price **\$5.15 F**



SKIN TIGHT

PROFILE OF A JAZZ DRUMMER

Contents: Pink Ice; Cottontail; Say What?; Like Help; I May Be Wrong; I'll Take Romance; The Lady Is A Tramp.

Featuring: Phil Woods; Bob Wilber; Hank Jones; Jim Chapin; Urbie Green; Wilbur Ware; George Dorsey; Jim Nottingham.

Retail Price \$4.98 List Price **\$5.15 B**
CJ-7—Skin Tight Record

MUSIC MINUS ONE

NEW!
THE SOUND OF BRUSHES
THE SOUND OF JAZZ



THIS RHYTHM KIT CONTAINS:
• PROFESSIONAL BRUSHES
• LONG PLAYING RECORD
• INSTRUCTION BOOKLET
• PRACTICE DRUM PAD

398

U.S. PAT. 2,812,123

MMO 175

No. MMO 175—THE SOUND OF BRUSHES, LIST PRICE \$4.125



COMPLETE
WITH
DRUMSTICKS,
LP RECORD
AND EASY
INSTRUCTIONS

MMO 125

398

MUSIC
MINUS
ONE

No. MMO 125—FUN WITH DRUM STICKS, LIST PRICE \$4.125

ROGERS DRUM PRICES
include DELUXE CHROME
and FEDERAL EXCISE TAX

TERMS

ROGERS DRUMS ARE SOLD THROUGH
DEALERS IN OPEN TERRITORIES ONLY

All previous quotations cancelled. All prices are list, subject to change without notice and to the usual terms. PRICES INCLUDE FEDERAL EXCISE TAX. F.O.B. shipping point. New accounts please submit 3 trade references and bank.

Substitutions permissible. Colors matched on non-cancellable, non-returnable basis. Plastic heads standard on all drums, unless otherwise specified. All metal parts chrome plated. Heads and Cymbals not guaranteed.

Claims for losses, damages or pilferage must be made to the Transportation Company. Our responsibility ceases upon delivery to the Transportation Company. Shipments should be opened and examined immediately for loss or damage, either VISIBLE or CONCEALED.

Check all contents and save all cartons and packing material. Call your local agent at once for an inspection. Obtain a signed inspection report from him and file claim for loss or damage.

ROGERS MATS

A selection of attractive newspaper ad mats on Rogers Drums and Swiv-O-Matic equipment is available in single or double column size. Write for mat brochure.

DETAILED INDEX

Acme Whistles	82
Anchor	43
AVRDIS ZILDJIAN Cymbals	42
Bag	67, 68
Band Cymbal Holders	44
Basic Heads	63, 70
Base Drums	25, 29
Base Drum Beaters	64, 66
Base Drum Cradles	54, 55
Base Drum Stings	40
Batons	90, 91, 92
Baton Accessories	30, 31, 32
Beaters	64, 66
Bell Lyres (Gluckenspiels)	38
Bird Whistles	83
Bones	88
Bongo Cases	46, 35
Bongo Heads	71
Bongo Holders	76
Bongos	75
Books	83 to 88
Brazilian Gong	78
Brushes	51
BIDDY RICH Outfits	8, 7
Bible Accessories	27, 36
Bazles	27, 36
Cabasa (Cubano)	79
Caracas Maracas	77
Cases	66, 67
Castanets	73
China Lyres	34
China Mallets	33
China Bells	39
Center Sappers	73
Clevers	79
Cocktail Drums	18
Cocktail Foot Pedals	51
Collar Hooks	72
Coff Plates	52
Cymbal Drums	18
Concert Drums	26, 25, 29
Conga Drum Stands	74
Conga Heads	71
Congas	76
Cymbalettes	53
Concession Kits	64
Counter Hoops	71
Covers	37, 64
Cow Bells	81
Cowbell Holders	81
Cow Horn Grips	78
COZY COLE Outfits	10
Cymbals	54
Cymbal Accessories	14 to 49
Cymbal Cases	44
Cymbal Pads	44
Cymbal Holders	44, 43, 46
Cymbal Polish	48
Cymbal Patches	44
Cymbals	42, 43, 44
Cymbal Sizzlers	46
Cymbal Stands	46, 47
Cymbal Straps	44
Cymbal Tilters	46, 46, 47
DIXIE Drum Sticks	62
Drum Bags	68
Drum Brushes	61
Drum Cases	66, 67

Drumette Practice Pads	58, 59
Drum Heads	69, 70, 71
Drum Beaters	68
Drum Hooks	73
Drum Key Holders	73
Drum Keys	73
Drum Kits	22, 23
Drum Lyres	56
Drum Major Batons	90, 91, 92
Drum Major Whistles	82
Drum Outfits	6 to 83
Drum Records	38, 39
Drum Rods	73
Drum Stands	54, 55
Drum Sticks	62, 63
Drum Thrones	56
Drum-Glow Batons	91
DYNA-SONIC DRUMS	24, 25, 30, 31
Evans Plastic Heads	69
Extension Arms	45
Felt Washers	46
Fibre Drum Cases	46, 67
Fibre Glass Beaters	65
Fibre Glass Mallets	45, 89
Fibred Drums	31 to 33
Fifes for Drum Corps	37
Finger Cymbals	43
PIPS Silent Practice Drums	64
Fire Batons, Grover and Acers	30
Flesh Hoops	71
Foot Pedal, Drum	50, 51
Foot Pedal Parts	50, 74
Gluckenspiels Accessories	36, 37
Gluckenspiels	36
Gongs	43
Gong Stands	43
Gourds	78
Great Dane Beaters	66
Grocco Cymbals	43
Guiras	78
Get Snare	72
Hand Castanets	79
Hand Cymbal Holders	14
Heads	69, 70, 71
Head Tackers	71
Heaters	62
Hi-Hat Clutch	47
Hi-Hat Pedals	47, 48
Hi-Hat Spurs	47
Hi-Stopper Holder	41
Hoops	71
Illuminated Batons, Twirling	94, 91
Imitations	28
Indian Tom-Toms	30
Instruction Books	25 to 38
Instruction Records	84, 88
Internal Tone Controls	67
JET Four Pedals	51
Key Holders	73
Keys	73

Kits, Drum	22, 23
Knobby Attachments	45, 46, 52, 33
Latin-American Instruments	75 to 79
Leg Rests	44
L.H. BELLSON Outfits	11
Lyres	73
Lyres	56
Mallets	62, 89
Maracas	77
Marxophone Drums	30 to 33
Mazimba Mallets	65, 89
Marimbas	85
Mufflers	87
Music	93 to 94
Music Holders	58
Nylon Mallets	62, 89
Nylon Stings	40
Parade Drums	11 to 35
PASHA Cymbals	43
Pedal Beaters Covers	50
Pedal Beaters	50
Pedals, Foot	50, 51
Pedal Parts	50, 74
Piston Bagles	85
Plastic Drum Sticks	62
Plastic Heads	64, 74
Plastic Mallets	45, 89
Practice Pads	57, 58, 59
Practice Tips, Drum Stick	59
Pre-Drum Kits	25
Polishing Cloth	67
Portable Porter	67
Rain Covers	47
Ratchets	42
Rawhide Mallets	38
Resonator Bells	87
Rhumba Instruments	75 to 79
Rhythm Band Instruments	84, 85, 86
Rhythm Bells	87
Rocking Cops, Cymbal	44
ROCKET Foot Pedals	54
Rockstop, Spur Stop	14
Rods	73
ROGERS Batons	91
ROGERS Beaters	64, 65
ROGERS Bongos	75
ROGERS Heads	64
ROGERS Hi-Hat Cymbal Stands	47
ROGERS Mallets	65, 89
ROGERS Plextex Heads	68
ROGERS Snare	72
ROGERS "Starline" Sticks	43
ROGERS Strainers	78
ROGERS Wire Brushes	61
Rubber Mallets	49
Rubber Tips	49
Sam Browne Stings	40
Scotch Drum Beaters	64, 65
Scotch Drums	31 to 35
Signal Batons	90, 91
Siren Whistles	82
Sizzle Cymbals	42

Slogsticks	83
Sloughbells	81
Sting Holders	73
Stings	49
Snaps Snare	72
Snare	72
Snare Drums	25, 26
Snare Strainers	72
Stick Pedals	17, 48
Song Whistles	83
Sound Effects	81
Spurs	47, 49
Stands	54, 55
Sta-Tite Cymbal Holders	45
Stereo Brushes	63
Sticks	62, 63
Stick Trays	64
Strainers	72
Street Drums	31 to 35
SWIV-O-MATIC	
Cymbal Holders	45
Drum Holders	62, 63, 64
Foot Pedals	54
Hi Hat Cymbal Stands	47
Leg Rests	44
Strainers	72
Tilters	47
Tom-Tom Holders	62, 63
Tumbourines	82
Temple Block Holders	84
Temple Blocks	80
Temple Block Stands	80
Tenor Drum Beaters	64, 65
Tenor Drums	31 to 35
THREE STAR Banjo Heads	69
Thrones	56
Thumb Screws	72
Titles	46, 47
Timbales	78
Timbal Sticks	78
Tom-Toms	21
Tom-Tom Builders	52, 53
Tom-Tom Legs	58
Tone Controls	67
Triangles	80
Tubus	78
Tucking Tools	71
Tuned Time Bells	87
Tympani	39
Tympani Beaters	45
Tympani Heads	49, 74
Vibra Harp Covers	88
Vibra Harp Mallets	88, 89
Vibra Harps	88
Washers, Felt and Rubber	46
WEATHER KING Heads	74
WEATHER KING Practice Pads	59
WEATHER KING Sticks	62
Whistles	82
White Bums, African	80
Wire Brushes	61
Wire-Wound Snare	72
Wood Blocks and Holders	61
Al G. Wright Bell-Lyre Mallets	88
Xylophone Mallets	45, 55
ZILDJIAN Cymbals	42
ZILDJIAN Cymbals	42

Louis Bellson



ONLY ROGERS HAS *dyna-sonic*

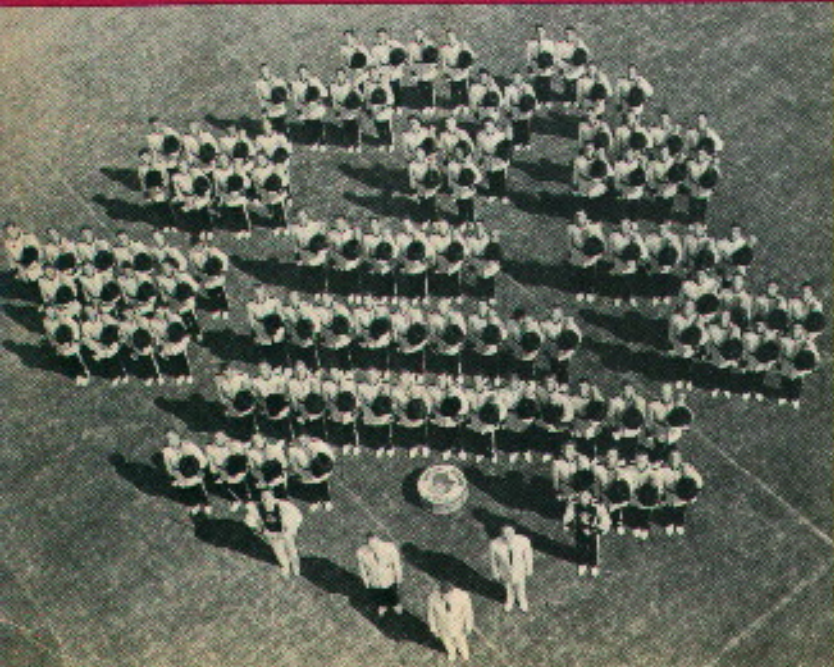

UCLA MARCHING BAND with Rogers YORKTOWN Drums



SOUTHERN ILLINOIS UNIVERSITY with Rogers DYNA-SONIC Drums