

# ROGERS DRUMS<sup>®</sup>

U.S.A.

*Creators of new concepts in percussion*

*CATALOG 67-68*

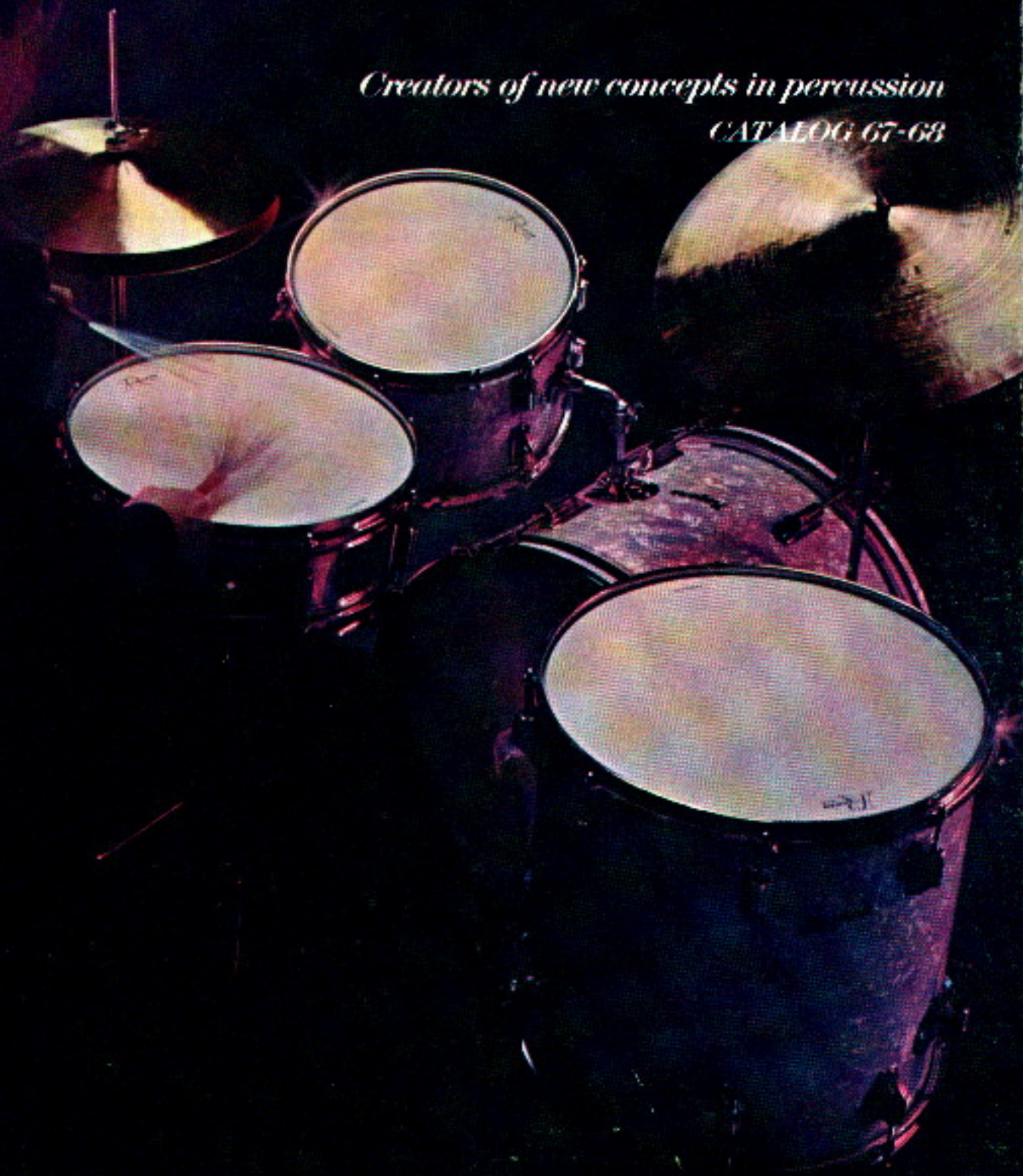



Fender Service Center,  
722 17<sup>th</sup> Ave South  
Nashville, Tenn.

**THIS** is a colorful presentation of the Rogers percussion story. You'll find striking evidence on these pages of our company's determined efforts to improve percussion equipment — musically and physically.

Why? Because we believe in percussion. Because we believe percussionists have a right to better equipment — so they can **perform musically**, play with authority. Here then is the Rogers story.

CONTENTS		Page
INTRODUCTION . . . . .		2-3
DRUM SETS . . . . .		4-13
SNARE DRUMS . . . . .		14-18
DRUM KITS . . . . .		19-20
TOM TOMS . . . . .		21-40
BASS DRUMS . . . . .		22-28
MARCHING DRUMS . . . . .		23-29
SWIV-O-MATIC ACCESSORIES . . . . .		30-33
SWIV-O-MATIC TOM TOM HOLDERS . . . . .		31
STANDS, HOLDERS AND LEGS . . . . .		32-33
H-HATS AND ACCESSORIES . . . . .		34-38
FOOT PEDALS AND PEDAL BEATERS . . . . .		36-37
SNARES AND STRAINERS . . . . .		38
THRONES . . . . .		38-39
CONCERT PERCUSSION . . . . .		40
TIMBALES AND BONGOS . . . . .		41
LATIN AMERICAN ACCESSORIES . . . . .		42-43
PERCUSSION ACCESSORIES . . . . .		43-44
COVERS . . . . .		45
BEATERS . . . . .		46-47
LEG RESTS AND SLINGS AND SPURS . . . . .		47
STICKS AND BRUSHES . . . . .		48-49
PRACTICE SETS . . . . .		50-51
CYMBALS AND ACCESSORIES . . . . .		52-53
DRUM HEADS . . . . .		54-55
MALLET PERCUSSION AND MALLETS . . . . .		56-58
DRUM CASES . . . . .		60
BOOKS AND EDUCATIONAL AIDS . . . . .		61-63
INDEX . . . . .		64
FINISHES . . . . .		65



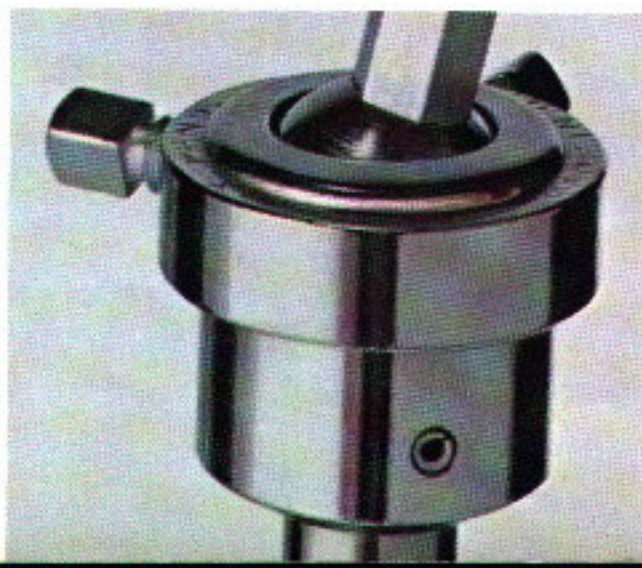
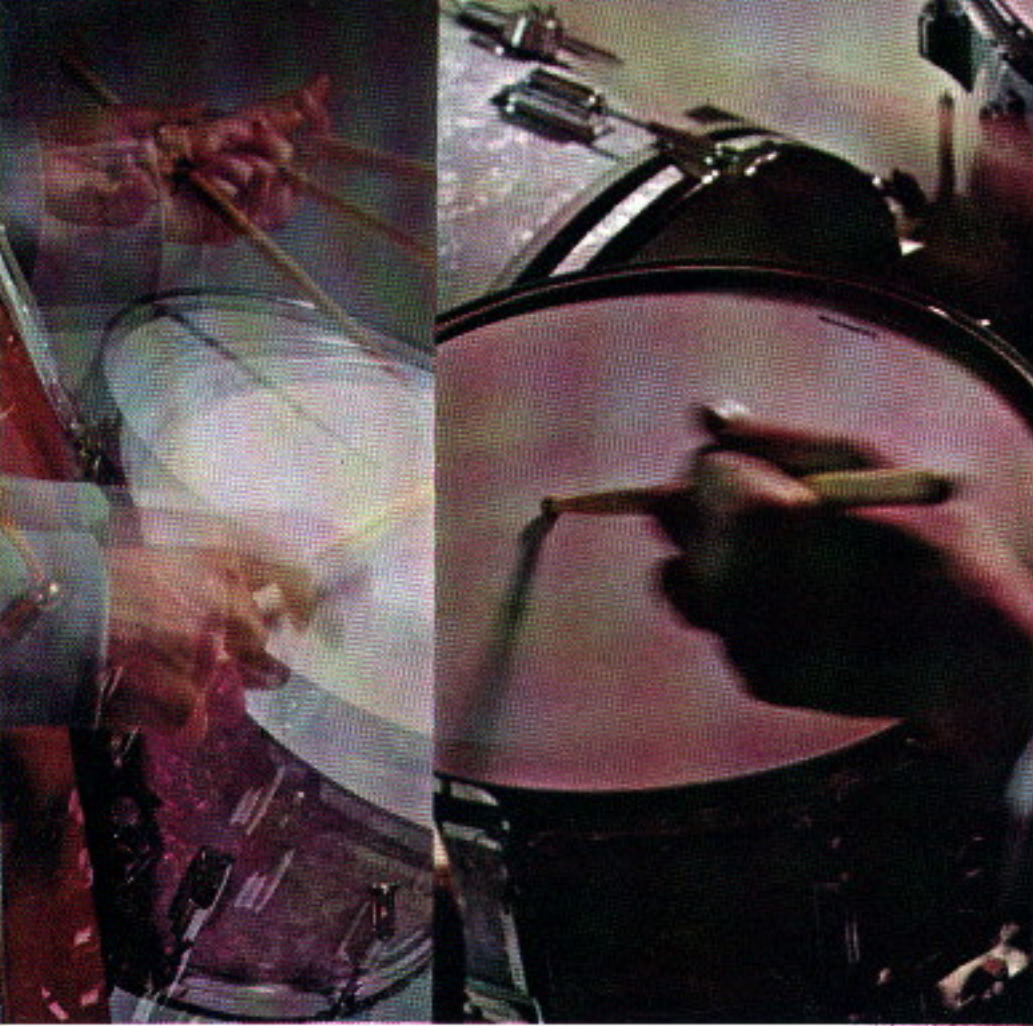

## WE LOVE DRUMS

and the drummers who play them!

Now, that may seem like a strange way to start a drum catalog. But that's what this catalog is all about: Rogers' continued dedication to better drum manufacture.

It all started more than 100 years ago — because that's how long Rogers has been in the drum business. But it was less than 15 years ago, in the small town of Covington, Ohio, that today's Rogers story starts.

From the fertile mind of a drumming genius, ideas began to flow. Ideas that would make a drummer's life easier. Ideas that would put the fun back in drumming. Ideas that would help a drummer improve his sound and his technique. The genius was Joe Thompson, who is still working hard to do things for drummers.

Until 1958, drum attachments had been pretty much the same over the years. Nobody seemed to worry much that a drummer had to be part mechanic, or that the attachments never really did all they were supposed to do. **Swiv-o-matic** changed all that. Swiv-o-matic's revolutionary ball-and-socket adjustment — all with a drum key — gave drummers any angle, any direction. Most important, once set, they stayed put. 100%. No movement, no falling, no tinkering. Cymbals and tom-toms could be taken down and set up instantly. Angle-height-direction remained exactly as before.

A few years later, drummers were startled to find a new kind of drum. It was called **Dyna-Sonic**. Amazingly, the snares weren't attached to the drum. They were attached to a snare frame — to make possible an amazing increase in definition, projection, sensitivity and pure musical sound.

Year after year, Rogers introduced new ideas. Every one with the specific goal of helping the drummer. A new kind of throne. A hi-hat that's the smoothest on the market. Nylon snares for schools. Ideas. Some major. Some minor. Like the tension rods in all new Rogers bass drums. They're made differently than any tension rods ever — so the handle can't possibly pull off. A little thing? Yes, but a basic improvement.

Fifteen years ago, chances are you never heard of Rogers. Today, Rogers is a name to reckon with in percussion. This catalog is beautiful evidence that Rogers continues to love drummers — and continues to make percussion instruments that perform and sound better than any other.

Rogers drums and equipment have won high honors from top drummers the world over. Today Rogers is honored to be part of one of the world's great organizations, The Columbia Broadcasting System, Inc., whose resources guarantee an even brighter future for Rogers Drums.

**ROGERS/creators of new concepts in percussion.**

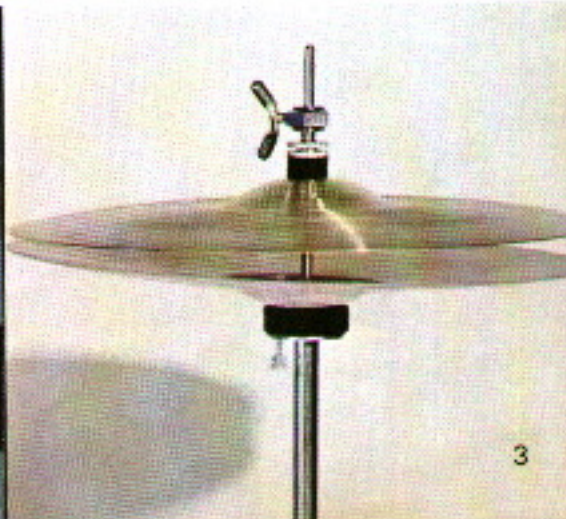
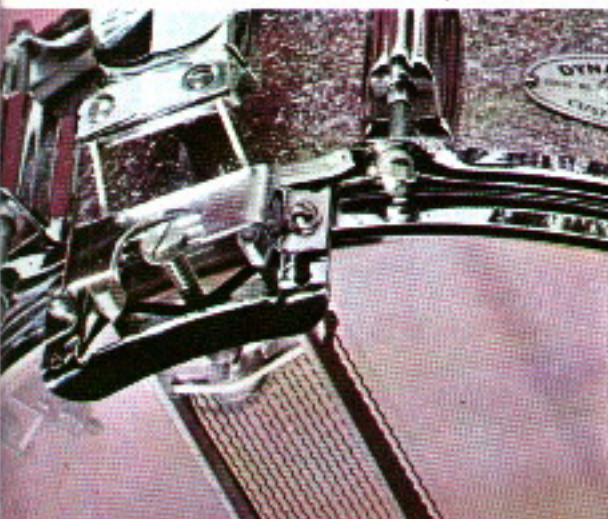



## Buddy Rich 'CELEBRITY'

**TAKE** a good look at Buddy Rich's own set-up. Get amazing versatility with the Celebrity. You'll handle all jazz, solo and "big band" engagements with professional ease. Famed Dyna-Sonic snare, Swiv-o-matic "set 'em and forget 'em" holders, and super-swift Swiv-o-matic pedal. Perfection in drums for perfectionists in drumming.

### 2802 outfit

Available in choice of pearl finishes — see page 85

- 91 Holiday 14x22 bass drum**  
340 internal spurs, mounted
- 360 Swiv-o-matic tom-tom holder, mounted
- 252 Knobby telescopic cymbal holders (2), mounted
- 53 Holiday 9x13 tom-tom**
- 59K Holiday 16x16 tom-tom, with Knobby legs**
- 32 Dyna-Sonic 5x14 snare drum**
- 4012 Rogers giant drum stand
- 395 Swiv-o-matic foot pedal
- 4402 Swiv-o-matic hi-hat
- 4403 Floor cymbal stands (2)
- 6109 Buddy Rich BR\* drum sticks
- 940 Buddy Rich wire brushes

For cymbals, see pages 52-53.

Finish shown: *silver sparkle*





## Buddy Rich 'HEADLINER'



*BUDDY RICH—the drummer's drummer. "Rich is the greatest technician jazz drumming has ever known." So says DOWN BEAT. He demands more out of a drum than most manufacturers put into it. That's why Buddy Rich plays Rogers.*

**HIT** the headlines with HEADLINER! Here's the tonal versatility and quality construction sought by today's most discriminating professional drummer. Everything's here. The outstanding sound projection of the PowerTone metal snare, the faster set-ups and never-slip adjustments of Swiv-o-matic holders, the lightning-quick Swiv-o-matic pedal action. With HEADLINER, musicians and audiences know you've arrived. So do you!

### 2806 outfit

Available in choice of pearl finishes — see page 65

- 87 **Holiday 14x20 bass drum**  
338 internal spurs, mounted
  - 252 **Knobby telescopic cymbal holder, mounted**
  - 361 **Swiv-o-matic tom-tom holder, mounted**
  - 51 **Holiday 8x12 tom-tom**
  - 59K **Holiday 16x16 tom-tom, with Knobby legs**
  - 28 **PowerTone 5x14 metal snare drum**
  - 4012 **Rogers giant drum stand**
  - 396 **Swiv-o-matic foot pedal**
  - 4401 **Swiv-o-matic hi-hat**
  - 6109 **Buddy Rich BR\* drum sticks**
  - 940 **Buddy Rich wire brushes**
  - Dyna-Sonic Snare drum optional.
- For cymbals, see pages 52-53.

Finish shown: *marine pearl*



## ROGERS 'CELEBRITY'

**TAKE** a good look at this set-up. Get amazing versatility with the Celebrity. You'll handle all jazz, solo and "big band" engagements with professional ease. Famed Dyna-Sonic snare, Swiv-o-matic "set 'em and forget 'em" holders, and super-swift Swiv-o-matic pedal. Perfection in drums for perfectionists in drumming.

### 2802 outfit

Available in choice of pearl finishes — see page 85

- 91 Holiday 14x22 bass drum**  
340 internal spurs, mounted  
360 Swiv-o-matic tom-tom holder, mounted  
252 Knobby telescopic cymbal holders (2), mounted
- 53 Holiday 9x13 tom-tom**
- 59K Holiday 16x16 tom-tom, with Knobby legs**
- 32 Dyna-Sonic 5x14 snare drum**
- 4012 Rogers giant drum stand
- 395 Swiv-o-matic foot pedal
- 4402 Swiv-o-matic hi-hat
- 4403 Floor cymbal stands (2)
- 6100 RB\* Drum sticks
- 940 Wire brushes

For cymbals, see pages 52-53.

Finish shown: *silver sparkle*







## ROGERS 'TIMBALE-TWIN'

**THE SET** to set your group apart in sound and style. Twin bass drums and timbales team to produce big beats and unusual rhythms. Here's the choice of professional rhythm n' blues and rock groups "moving out" for varied tonal colorings and unique sounds.

### 2834 outfit

Available in choice of pearl finishes — see page 65

- 87 Holiday 14x20 bass drums (2)
- 338 internal spurs (2 pr.) mounted
- 4907 Timbales with stand. Chrome finish. Plastic heads.
- 59K Holiday 16x16 tom-tom, with Knobby legs
- 28 PowerTone 5x14 metal snare drum
- 4009 Rogers drum stand
- 396 Swiv-o-matic foot pedals (2)
- 4401 Swiv-o-matic hi-hat
- 4405 Floor cymbal stands (2)
- 6104 Drum sticks, 5A
- 940 Wire brushes

Dyna-Sonic snare drum optional

For cymbals, see pages 52-53





New 359 hi-hat attachment. The only way to get a comfortable, close position with twin bass set up.

LOUIS BELLSON rates raw notes as percussional, con-gover, educator and clinician. With a secure spot on the top of the percussion ladder, Louis Bellson plays Rogers Drums. Of course!

## Louis Bellson 'TWIN-BASS'

GET the famed Bellson "big beat" with this Rogers "TWIN-BASS" outfit. You'll open up a whole new range of tonal colorings and rhythmic possibilities for yourself. Here's a unique set-up for the serious professional seeking to "pull all the stops" on his creative drumming capabilities.

### 2837 outfit

Available in choice of pearl finishes — see page 65

- 91 Holiday 14x22 bass drums (2)  
340 internal spurs (2 pr.), mounted
- 252 Knobby telescopic cymbal holders (2)
- 361 Swiv-o-matic tom-tom holder, mounted
- 359 hi-hat attachment, mounted
- 53 Holiday 9x13 tom-tom
- 59K Holiday 16x16 tom-tom, with Knobby legs
- 32 Dyna-Sonic 5x14 snare drum
- 4012 Rogers giant drum stand
- 396 Swiv-o-matic foot pedals (2)
- 4401 Swiv-o-matic hi-hat
- 6110 Louis Bellson LB™ drum sticks
- 940 Wire brushes

For cymbals, see pages 52-53



Finish shown: blue sparkle

## ROGERS 'CITADEL'

**SET UP**, swing through the night. Pack up, move on to the next "gig". The pros pick CITADEL for "one nighters". Get big sound and broader tonal range in a sturdy, compact set. Top materials combine with Rogers craftsmanship to guarantee your set will stand up to night-after-night wear-and-tear with no sacrifice in the sound quality demanded in professional work.

### 2845 outfit

Available in choice of pearl finishes — see page 65

- 87 **Holiday 14x20 bass drum**  
338 internal spurs, mounted  
361 Swiv-o-matic tom-tom holder, mounted
- 51 **Holiday 8x12 tom-tom**
- 55K **Holiday 14x14 tom-tom, with Knobby legs**
- 36 **Dyna-Sonic 5x14 metal snare drum**
- 4009 Rogers drum stand
- 396 Swiv-o-matic foot pedal
- 4401 Swiv-o-matic hi-hat
- 4403 Floor cymbal stand
- 4788 Cowbell
- 280 Adjustable cowbell holder
- 6104 Drum sticks, 5A
- 940 Wire brushes

For cymbals, see pages 52-53



Finish shown: *red onyx*



*From his early days with Ellington right up to the moment, COZY COLE steps along at the head of the percussion parade. His keen musical sense made him an early convert to Rogers.*

## Cozy Cole 'CONSTELLATION'

REACH for the pinnacle of percussion perfection! Modeled after the famed Cole set-up, here's sound flexibility which makes this outfit the choice of top-ranked pros with top flight musical assignments.

### 2852 outfit

Available in choice of pearl finishes — see page 65

- 91** Holiday 14x22 bass drum  
340 internal spurs, mounted
- 331 internal cymbal holders (2), mounted
- 360 Swiv-o-matic tom-tom holder
- 53** Holiday 9x13 tom-tom
- 59K** Holiday 16x16 tom-tom, with Knobby legs
- 25** PowerTone 5x14 snare drum
- 4011 Rogers drum stand
- 398 Rocket foot pedal
- 4401 Swiv-o-matic hi-hat
- 320 Swiv-o-matic cymbal tilters (2)
- 325 Swiv-o-matic cymbal extension arm
- 6111 Cozy Cole CC\* drum sticks
- 940 Wire brushes

Dyna•Sonic snare drum optional.

For cymbals, see pages 52-53.



Finish shown: *black onyx*



## Dave Clark 'LONDONER'

"I LIKE IT LIKE THAT," says Dave Clark about his new Rogers outfit. Here's the way to hold resonant drive and up-tempo splashes of sound. This "Dave Clark sound" makes the LONDONER the accepted standard among today's "mod music makers." You'll LIKE IT LIKE THAT, too!

### 2873 outfit

Available in choice of pearl finishes — see page 85

- 87 Holiday 14x20 bass drum  
338 internal spurs, mounted
- 366 Swiv-o-matic dual tom-tom holder, mounted
- 51 Holiday 8x12 tom-tom
- 53 Holiday 9x13 tom-tom
- 59K Holiday 16x16 tom-tom, with Knobby legs
- 25 PowerTone 5x14 snare drum
- 4009 Rogers drum stand
- 398 Rocket foot pedal
- 4401 Swiv-o-matic hi-hat
- 4405 Floor cymbal stands (2)
- 6104 Drum sticks, 5A
- 940 Wire brushes

Dyna-Sonic snare drum optional.

For cymbals, see pages 52-53.

Finish shown: *red sparkle*



Finish shown:  
grey ripple



## ROGERS 'COMET'

**EXCELLENT** start for the beginner, providing the basic equipment to which extra pieces can be added. A good set to "grow on".

### 2885 outfit

Available in choice of pearl finishes — see page 65

- 73 Tower 14x20 bass drum
  - 338 internal spurs, mounted
  - 331 internal cymbal holder, mounted
  - 361 tom-tom holder, mounted
- 43 Tower 8x12 tom-tom
- 15 Luxor 5x14 snare drum
- 4010 Banner snare drum stand
- 399 Jet foot pedal
- 320 Swiv-o-matic cymbal tilter
- 4788 Cowbell
- 4656 Cowbell holder
- 6104 Drum sticks, 5A
- 945 Wire brushes

For cymbals, see pages 52-53

## ROGERS 'DELTA'

**AN UP-TO-THE-MINUTE** drum outfit for the rising young drummer to develop percussion skills. Here's a set with qualities normally built only into more costly outfits.

### 2888 outfit

Available in choice of pearl finishes — see page 65

- 73 Tower 14x20 bass drum
  - 338 internal spurs, mounted
  - 331 internal cymbal holder, mounted
  - 361 tom-tom holder, mounted
- 43 Tower 8x12 tom-tom
- 49ST Tower floor tom-tom, with straight legs
- 15 Luxor 5x14 snare drum
- 4010 Banner snare drum stand
- 399 Jet foot pedal
- 320 Swiv-o-matic cymbal tilter
- 6104 Drum sticks, 5A
- 945 Wire brushes

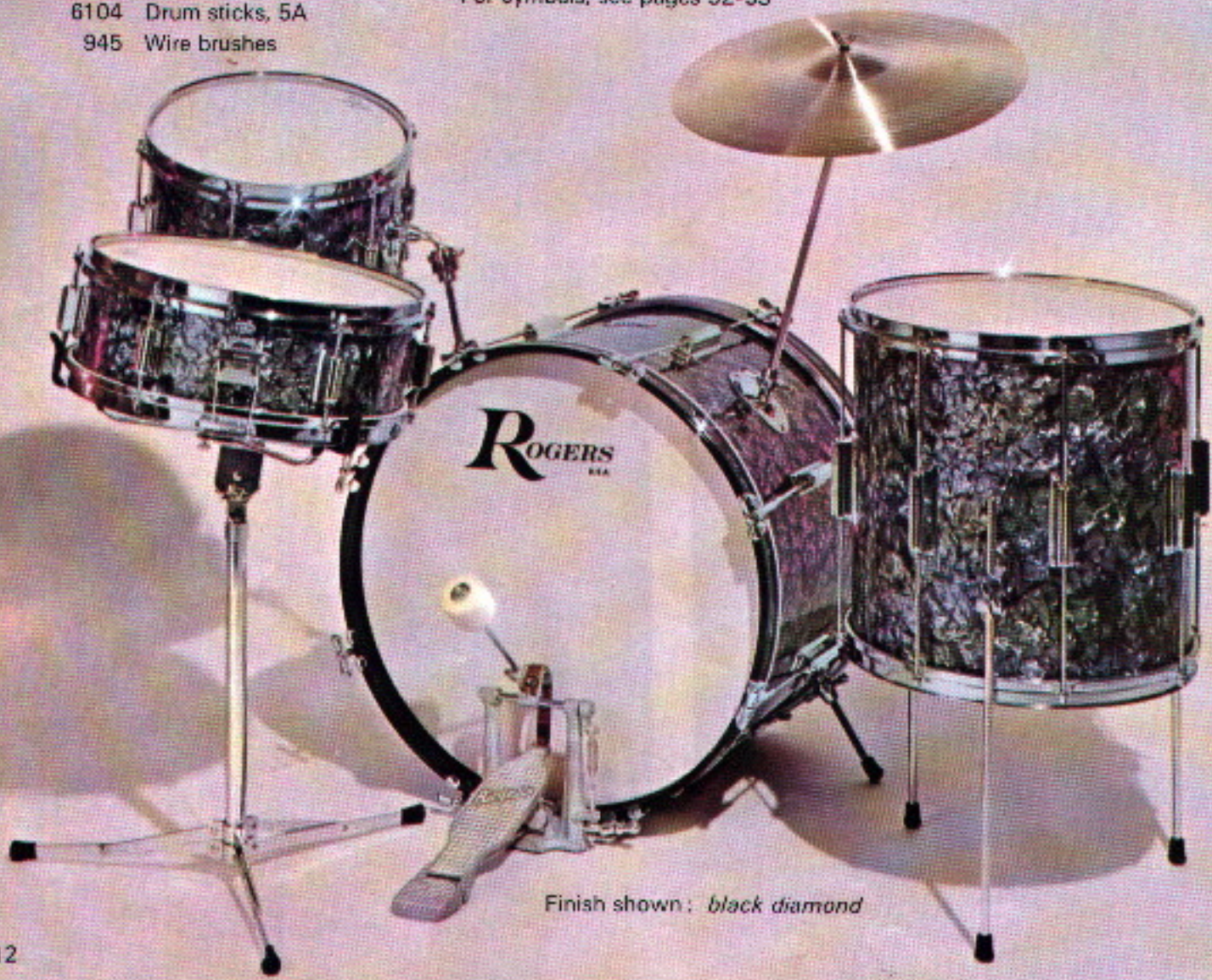

Finish shown: *black diamond*

## Roy Burns 'STARLIGHTER'

PERFECT percussion is the STARLIGHTER'S potential. It's customized for Roy Burns to give full reign to his progressive and melodic jazz musical stylings. If you have ideas about new percussion sounds, here's the set with the capacity you need, a brilliant showcase for the musical innovator.

### 2855 outfit

Available in choice of pearl finishes — see page 51

- 91 Holiday 14x22 bass drum  
340 internal spurs, mounted
- 252 Knobby telescopic cymbal holder, mounted
- 360 Swiv-o-matic tom-tom holder, mounted
- 53 Holiday 9x13 tom-tom
- 59K Holiday 16x16 floor tom-tom, with Knobby legs
- 38 Dyna-Sonic 5x14 metal snare drum
- 4009 Rogers drum stand
- 395 Swiv-o-matic foot pedal
- 4407 Swiv-o-matic hi-hat
- 4405 Floor cymbal stand
- 288 Stick tray assembly
- 6104 Drum sticks, 5A
- 945 Wire brushes

For cymbals, see pages 52-53.



*ROY BURNS. The author of the popular new beginner's instruction book and many others achieves brilliant new percussion sounds on Rogers.*



*Finish shown: pink champagne*

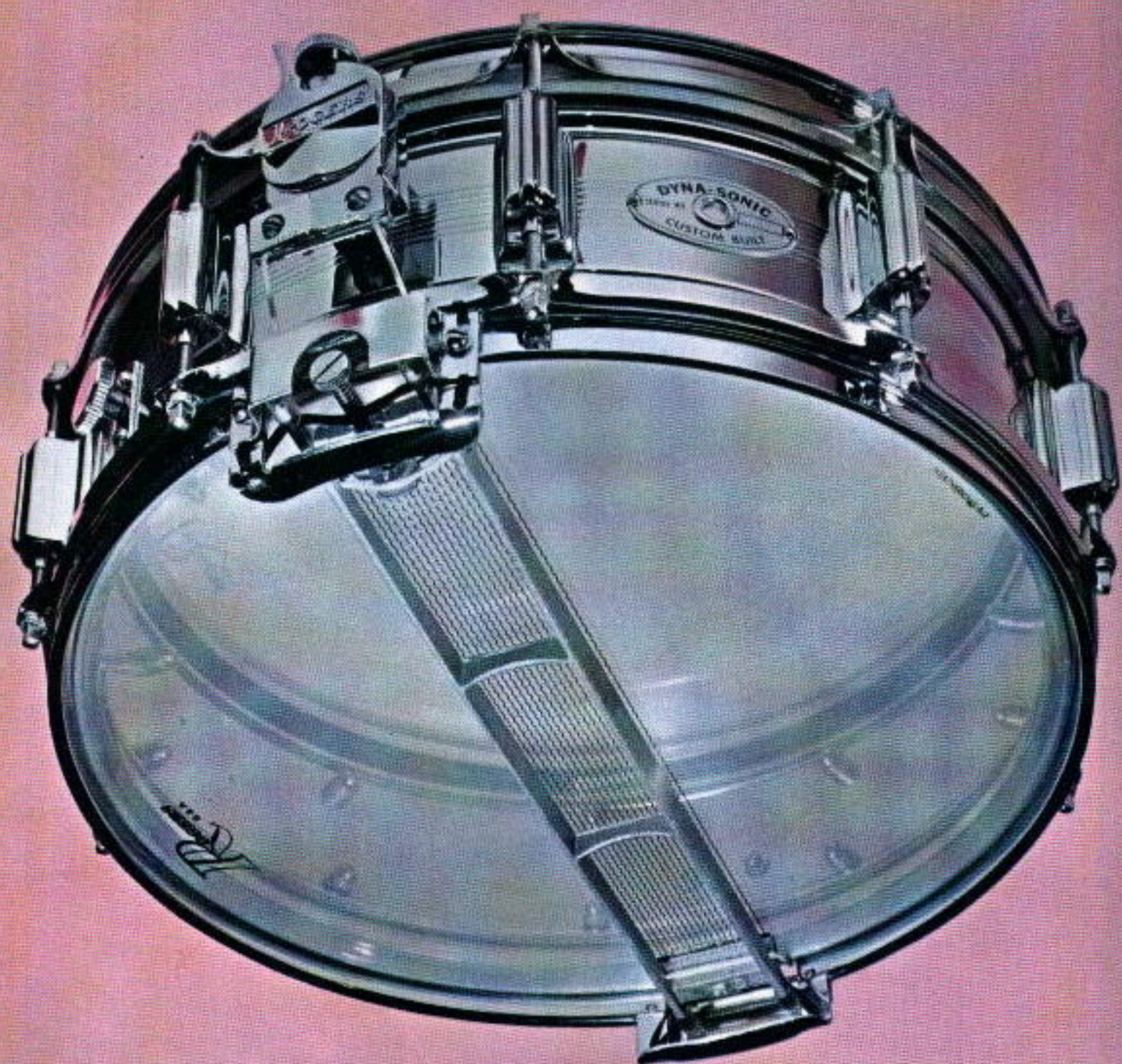



## Rogers DYNA-SONIC® snare drums... clean, crisp, clear sound with full definition.

**THIS** is the drum that "couldn't be built." This is the drum that solved a problem that "couldn't be solved."

Before Dyna-Sonic, you tightened the snares, and the snares choked the head.

Dyna-Sonic changes all that. Because your snares ride on an exclusive floating snare frame. They ride with the snare head, never dampen it. There's no choking. There's never a snare slap.

What does this mean to you? All this.

**1. PINPOINT DEFINITION.** You hear the result of each stroke, even at full power, always without distortion.

**2. CHOKE-FREE SOUND.** Always clear and crisp, never mushy.

**3. FASTER STICK REBOUND.** You get added speed and better feel with half the effort. Your drum head feels solid, never soft.

**4. FULL DYNAMIC RANGE.** Everywhere on the head. There are no dead spots, even at the edges. Your sound projects easily. You hear the snare sound clearly.

**5. THE SOUND OF MUSIC.** This drum has true musical sound. The tone quality is built in — a result of the matched relationship between new floating snares, heads, and custom-shell.

**6. SIMPLEST ADJUSTMENT OF ANY DRUM.** A single tension screw gives you one-point uniform tensioning. It stays as you set it. The new snare frame doubles as protective guard for the snares.

Could you ask for more?

### Dyna-Sonic Metal Snare Drums

Finest of drums with extra features for extra performance: chrome plated brass custom shell. Triple flange hoops, 10 self-aligning lugs, separate tension, internal tone control, Swiv-o-matic strainer, polished chrome fittings and exclusive floating snare frame assembly.

- 36 5x14 with wire snappy snares
- 37 6½x14 with wire snappy snares
- 39 6½x14 with nylon snares
- 46 6½x14 with gut snares

Take the Dyna-Sonic side-by-side test—and see for yourself. Play a Dyna-Sonic drum beside your present drum. Compare. Then you'll know.

Sure it's different.

It may require some getting used to — like power steering. But, doesn't anything new and better require getting used to? A little time spent with Dyna-Sonic will pay big dividends as you discover what this new drum can do for your technique.



### Dyna-Sonic Pearl Snare Drums

For those drummers who prefer the tone produced by the custom cross-laminated wood shell. Choice of pearl finishes.

- 32 5x14 with wire snappy snares
- 33 6½x14 with wire snappy snares
- 34 6½x14 with nylon snares
- 47 6½x14 with gut snares



Finish shown: blue sparkle



## ROGERS POWERTONE®

**a new kind of drum gives you full snare head action – and a smooth, rich sound.**

IT'S what you can't see on PowerTone that counts. And you can't see the snare bed. It's invisible. This means you get the sound you want without excessive tightening of snares.

**Think** about that for a moment. Your snares won't choke the head. And your snare head has freedom to do what it must do: vibrate fully over its entire surface.

**It's** just that simple. But that simple difference gives you sound that's smooth and rich. Your sound is alive, projects 'out' where you want it without pounding. There are no dead spots anywhere – just live sound right to the edge of the head. Live sound and better sound because of PowerTone's exclusive acoustic shell properties in both the all-metal brass shell and the cross-laminated wood shell.

**You** can hear and feel the difference.

**When** you play PowerTone.

### PowerTone Snare Drums

Each PowerTone snare drum is complete with Swiv-o-matic strainer, polished chrome fittings, 8 self-aligning lugs, separate tension, triple flange hoops, internal tone control, and 20-strand wire snappy snares.

- 28 5x14 all brass shell, chrome plated
- 29 6½x14 all brass shell, chrome plated
- 25 5x14 pearl
- 27 6½x14 pearl
- 24 5x14 mahogany or lacquer
- 26 6½x14 mahogany or lacquer

Specify finish.

Finish shown: *red sparkle*



## CENTURY CONCERT DRUMS

**SHARP, POWERFUL.** Separate tension. For the concert band or orchestra. Swiv-o-matic strainer. Sturdy cross-laminated shell and rock maple reinforcing rings. Chrome plated fittings, deluxe triple flange hoops, and internal tone control. 16 self-aligning lugs. 20-strand snares.

Pearl	Mahogany or Lacquer
31 8x15	30 8x15

Specify finish. Finish shown: *mahogany*



## TOWER SNARE DRUMS

**MODERATELY PRICED.** Top value in a separate tension snare drum. Handsomely constructed, with chrome plated fittings, triple flange hoops and 8 self-aligning lugs. Sturdy cross-laminated shell and maple reinforcing rings. 16-strand snares. Sta-tite strainer and internal tone control.

Pearl	Mahogany or Lacquer
19 5x14	18 5x14
21 6 1/2 x 14	20 6 1/2 x 14
23 6 1/2 x 15	22 6 1/2 x 15

Specify finish. Finish shown: *champagne*

## ROGERS SNARE DRUMS



## LUXOR SNARE DRUMS

**EVEN** at Luxor's low price, you get separate tension, durable cross-laminated shell construction with rock maple reinforcing rings, triple flanged hoops, 6 self-aligning lugs, internal tone control, 16 strand snares, and chrome plated fittings. Good looks combined with sturdy construction and fine tone. Excellent choice for the budget-minded who want Rogers drum quality.

Pearl	Mahogany or Lacquer
15 5x14	14 5x14
17 6 1/2 x 14	16 6 1/2 x 14

Specify finish. Finish shown: *black and gold lacquer*

## POWERTONE DRUM KIT

Everything's here to get the serious student drummer off on the right beat. The right equipment and educational approach to correlate school instruction and home practice. All in one attractive, easy-to-carry case. This kit starts with the PowerTone all-metal brass shell snare, an ideal drum around which to build a complete outfit.

### 1599 kit

- 28 PowerTone 5x14 metal snare drum
  - 1028 Remo 6" tunable practice pad
  - 7387 Practice pad platform
  - 4011 Snare drum stand
  - 6104 Drum sticks, 5A
  - 940 Wire brushes
  - 7190 "Sounds For Success" percussion record
  - 7100 "Elementary Drum Method," by Roy Burns
  - 983 Deluxe hard shell case . . . rich, plush-lining with durable vinyl on rugged wood body.
- Pearl snare drum optional. Specify finish.



## TOWER DRUM KIT

**SCHOOL** special. Excellent starter set, here's an 8 self-aligning lug, separate tension drum at a moderate price. The durability and sound quality to take any student to the threshold of professional drumming. Chrome plated hardware, internal tone control, 16-strand snares and Sta-tite professional strainer.

### 1595 kit

- 19 Tower 5x14 pearl snare drum
- 4010 Drum stand
- 991 "Vinalite" carrying case
- 6104 Drum sticks, 5A

Specify finish.

Finish shown: *marine pearl*

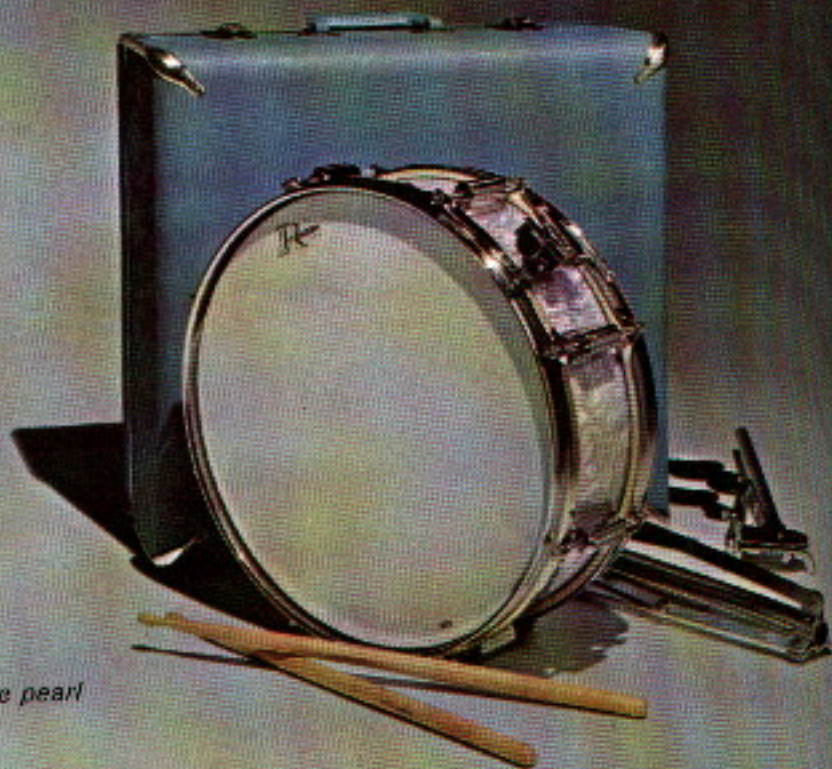

## LUXOR DRUM KIT

**OFFERS** the new drummer economy and service in his first drum. Compact and durable, this low-priced favorite incorporates such top flight features as separate tension, Bantam strainer, 6 chrome plated self-aligning lugs, tone control and 16-strand snares.

### 1593 kit

- 14 Luxor 5x14 snare drum
- 991 "Vinalite" carrying case
- 4010 Drum stand
- 6104 Drum sticks, 5A

Available in black-and-gold or blue-and-silver lacquer, and mahogany.

Pearl optional. Order Kit 1594.

Specify finish.

Finish shown: *black-and-gold lacquer*

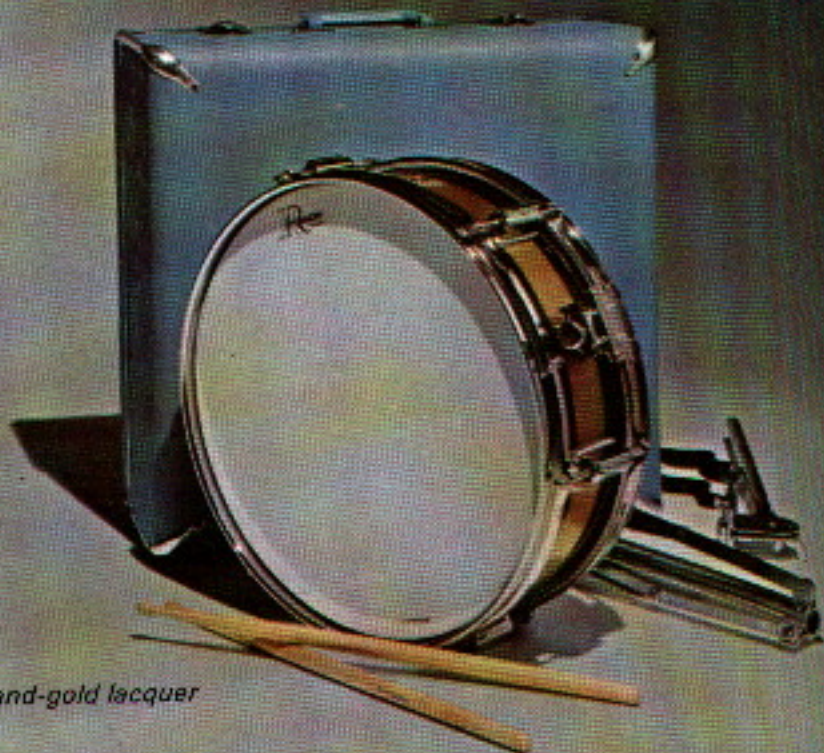

## Rogers HOLIDAY TOM-TOMS

Made with the same care and attention to musical sound as Rogers snare drums. Because of unique acoustic design innovations, you get live musical sound with total projection. Each tom-tom features triple flange hoops, deluxe chrome fittings and separate tension.

### Floor Tom-Toms with knobby legs, mounted

Pearl		Lacquer	
55K	14x14	54K	14x14
57K	16x14	56K	16x14
59K	16x16	58K	16x16
61K	16x18 (4 legs)		

Specify finish.

Finish shown: *red sparkle*



## Tower TOM-TOMS

Quality at a moderate price best describes the Tower line of tom-toms. Separate tension, centered self-aligning lugs, triple flange hoops and deluxe chrome hardware.

### Floor Tom-Toms with legs

Pearl		Lacquer	
49ST	14x14 Straight legs	48ST	14x14
49F	14x14 Flare legs, not shown	48F	14x14



Finish shown: *blue-and-silver lacquer*

Specify finish.

### Holiday Tom-Toms

Pearl	Lacquer
51 8x12	50 8x12
53 9x13	52 9x13

### Tower Tom-Toms

Pearl	Lacquer
43 8x12	42 8x12
45 9x13	44 9x13

Holders not included. For tom-tom holders and collet plates, see pages 31 and 33.

## ROGERS HOLIDAY BASS DRUMS

Noted for outstanding deep, resonant tone, these bass drums also offer spotlight-worthy appearance. They have become the first choice of musicians who care because of their superior construction which maintains beautiful tone over the years. Dual row of self-aligning lugs, separate tension, deluxe chrome plated fittings, and cross laminated shell with rock maple reinforcing rings complete the picture of the perfect bass drum.

Pearl	Mahogany and Lacquer
83 14x18	
85 12x20	84 12x20 (lacquer only)
87 14x20	86 14x20 (lacquer only)
89 12x22	88 12x22
91 14x22	90 14x22
93 14x24	92 14x24
95 14x26	94 14x26
97 14x28	96 14x28

Specify finish.

## TOWER BASS DRUMS

The economy of center mounts permits this series of **separate tension** bass drums to answer for quality on a budget. Self-aligning lugs and improved claws provide sure, even head tension comparable to that of more costly drums. Deluxe chrome-plated fittings and cross-laminated shell with rock maple reinforcing rings provide the easily recognizable marks of Rogers drum construction.

Pearl	Mahogany and Lacquer
73 14x20	72 14x20
75 14x22	74 14x22
77 14x24	76 14x24
79 14x26	78 14x26
81 14x28	80 14x28

Specify finish.

Finish shown: *mahogany*

*Inside pearl hoops standard on pearl drums, extra on lacquer finishes.*



You'll find an amazing new tension rod on every Rogers bass drum. It's designed with cold head construction so that the handle and rod can't separate ever. Small thing? Perhaps. But it's Rogers attention to detail that makes life more carefree for drummers and band directors.

Finish shown: *red sparkle*





## How in the world can a band director be sure he has the right percussion sound?

It's not easy.

**BUT** there are certain guide lines to follow. And some specifics to test for.

Rogers believes in Rogers, of course. We believe you can hear the difference — when you compare Rogers and other drums under performance conditions.

We call it the "Side by Side" test. It's just that. Take two of your top drummers. Give one any non-Rogers drum you can find. Give the other a Rogers Dyna-Sonic. Put them at one side of the field. You stand at the other. They play. You listen. Now, let them trade drums and listen again.

Listen to the notes — are they defined or run together?

Listen to the quality of sound — is it clean or muddy?

Listen to the projection of sound — does it reach your ear strong and vibrant or weak and fading?

Now, ask your drummers which drum feels better? Which requires the most work, which head feels most solid? Which drum is more responsive? Which drum they'd rather play?

Fair test? Of course!

The floating snare assembly and custom-built shell of Rogers Dyna-Sonic give you things no other drum can match: more sensitivity, sharper definition, crisper sound, faster stick rebound, greater projection, better feel. There's good reason for this technically — **but you can actually hear the difference.**

The Rogers Drums shown in this marching section represent total dedication to the director's needs and opportunities. Rogers drums are made to last. This means you can afford better sound because you won't replace as often.



**Rogers Dyna-Sonic leader in the parade!** These two drums represent the kind of Rogers dedication to drumming that means you can specify Rogers with confidence. On the left, **Dyna-Sonic** — which we feel is the finest drum made anywhere in the world today. On the right, **Pageant** — the lowest price drum Rogers makes. Yes, for this low price, you get **separate-tension**. Surprised? You shouldn't be. Rogers simply doesn't believe in making drums that don't do what they're supposed to do — and no single tension drum can give you the performance you have a right to expect.



## ROGERS DYNA-SONIC

**Delivers greater power, better sound with its custom shell and unique floating snare assembly.**

Everything about Rogers Dyna-Sonic drum rates it at the top of the list in marching bands the world over. Listen.

- more power — you get maximum projection with less effort, and without distortion
- snare response — even at pianissimo, you hear the snares
- crisp, clear sound — because the floating snares do not choke the drum — you hear each beat

Dyna-Sonic drums are sensitive, responsive. They bring out the best in student players. You can hear the difference in a side-by-side test. Your drummers will feel the difference.

The Dyna-Sonic floating snare frame gives you two extra advantages: one-point tension adjustment with a single screw, and snare protection (the frame acts as a guard!).

Each drum individually tested and inspected. Specify Dyna-Sonic and be sure.



### CHOOSE WIRE, NYLON, OR GUT SNARES

Rogers wire snares — for that snappy sound.

New Rogers Nylon or Gut snares — for the short, dry sound.



## ROGERS DYNA·SONIC MARCHING DRUMS

Swiv-o-matic snare strainer... deluxe triple flange hoops... 20 dual row self-aligning lugs... separate tension... chrome plated fittings... solid rock maple reinforcing rings... exclusive floating snare frame. Internal tone control on Parade and Tenor drums. Pearl inlaid hoops, standard on Scotch drums.

### Parade Drums

Wire Snares	Nylon Snares	Gut Snares
1531 10x14	1535 10x14	1545 10x14
1532 10x15	1536 10x15	1546 10x15
1533 12x15	1537 12x15	1547 12x15

### Tenor Drums

1571 12x15
1573 12x16

### Scotch Drums

1626 10x26
1628 10x28

### Rudimental Bass Drums

1637 12x24
1638 14x26
1639 14x28

Sticks and nylon sling included. Available in pearl or pearl combinations. Specify finish.



Finish shown: *silver sparkle*



## ROGERS CAMBRIDGE MARCHING DRUMS

Popular choice for quality and price. Cambridge wins favor because of its finer drum tone with full, distortion-free resonance. Here is the power and projection you need. Features eight center-mounted separate tension lugs, Sta-tite throw-off strainer, 16-strand snares, sparkling chrome-plated fittings, internal tone-control on Parade and Tenor drums, genuine mahogany cross-laminated shell and rock maple reinforcing. Inlaid pearl hoops standard on pearl Scotch drums, extra on lacquer finishes. Wood counter hoops optional at no extra cost on Parade and Tenor drums.

### Parade Drums

Pearl		Mahogany or Lacquer	
1521	10x14	1520	10x14
1514	10x15	1512	10x15
1523	12x15	1522	12x15

### Tenor Drums

Pearl		Mahogany	
1561	12x15	1560	12x15
1563	12x16	1562	12x16

### Scotch Drums

Pearl		Mahogany or Lacquer	
1606	8x26	1605	8x26
1608	10x26	1607	10x26
1611	8x28	1610	8x28
1613	10x28	1612	10x28

Sticks and slings included. Gut snares optional. Specify finish.



Finish shown: *mahogany*





## ROGERS POWERTONE MARCHING DRUMS

Fresh brilliance and projection result from the new PowerTone acoustically designed shell. Superior construction — and still competitively priced. Swiv-o-matic strainer, separate tension, 16 dual-row self-aligning lugs, 20-strand wire Snappy snares, deluxe chrome-plated fittings, and cross-laminated rock maple reinforced shell. The result: the optimum in marching drum design and construction. Internal tone control on Parade and Tenor. Pearl inlaid hoops standard on Pearl Scotch drums, extra on lacquer finishes.

### Parade Drums

Pearl		Mahogany or Lacquer	
1526	10x14	1525	10x14
1529	10x15	1524	10x15
1528	12x15	1527	12x15

### Tenor Drums

Pearl		Mahogany or Lacquer	
1566	12x15	1565	12x15
1568	12x16	1567	12x16

### Scotch Drums

Pearl		Mahogany or Lacquer	
1621	10x26	1620	10x26
1623	10x28	1622	10x28

### Rudimental Bass Drums

Pearl		Mahogany or Lacquer	
1632	12x24	1631	12x24
1634	14x26	1633	14x26
1636	14x28	1635	14x28

Sticks and slings included. Gut snares optional. Specify finish.



Finish shown: *marine pearl*

## ROGERS CONCERT BASS DRUMS

Only the best from Rogers where only the best will do. Acoustically designed shell is engineered to be the pick of the most discriminating musicians. Dual row of self-aligning lugs and separate tension allow most precise and sensitive head adjustment. Deluxe chrome fittings and shape-holding cross-laminated shell with rock maple reinforcement rings assure perfect tone and long life. Pearl inlaid hoops standard on all pearl models.

Pearl		Mahogany	
1701	14x30	1700	14x30
1703	14x32	1702	14x32
1705	16x30	1704	16x30
1707	16x32	1706	16x32
1709	16x34	1708	16x34
1711	16x36	1710	16x36
1713	18x40	1712	18x40

Specify finish.

Finish shown: *mahogany*



### 4015 BASS DRUM RACK

Solid. Sturdy. Made of 1" diameter steel tubing, chrome plated. Opens wide to accommodate any size bass drum.

## PAGEANT MARCHING DRUMS

For the first time at this price, a separate tension parade drum. Here's quality at a budget price with extra value features you don't expect to find in an economy marching drum. Bantam strainer provides instant throw-off. Chrome-plated fittings, 12-strand wire "Snappy" snares. Genuine mahogany laminated shell, solid rock maple reinforcement rings and 6 separate-tension center lugs round out Pageant drums to give you a faithful long-lived performer. Mahogany only.

1510 10x14 Pageant, separate tension



## DRUM & BUGLE CORPS KNOW DRUMS

That's the reason so many top corps choose Rogers — and win with Rogers.

The drums make all the difference between a winning performance and just another entry. Rogers scores for the corps — on looks and sound.

Only with Rogers do you get the Dyna-Sonic floating snare frame. It's specially designed to make the most of gut and nylon snares. Your sound with Dyna-Sonic is short, dry — the wanted corps sound. It projects fully. The definition is more precise than with any other drum. There's no distortion — just more musical sound, with each beat crisp and clear.

Watch with pride as your line flashes by, sparkling highlights flashing off the brilliant Rogers finish. Listen with pride as your sound reaches the level you've been rehearsing to achieve.

Sure, you can make it with other drums. It's just easier with Rogers.

Drums with the difference. The difference you can hear!



## ROGERS SWIV-O-MATIC

the idea that revolutionized drumming!

Today, drummers no longer worry about cymbals and tom-toms falling, twisting, turning. Swiv-o-matic changed all that.

For the first time, every drummer knows that his equipment will **stay put** — through a whole evening's drumming or through a whole year.

Your set-up and take-down is instant. There's no more juggling, no more wrenching, no more tinkering. Before a performance, during it, or after.

The secret's in the patented ball-and-socket design — and the no-turn hex rods. You'll find a complete line of Swiv-o-matic and complementary Knobby attachments on the following pages.

Swiv-o-matic attachments adjust instantly to any angle, any height, any direction. Once set, they stay put. And all you need to adjust them is your drum key. Imagine that. Can you think of one good reason why you're not Swiv-o-matic-equipped?



### 320 SWIV-O-MATIC CYMBAL TILTER.

All-direction tilter. Cymbal tilts to any playable direction within 360°. Cut-out provides 90° angle.

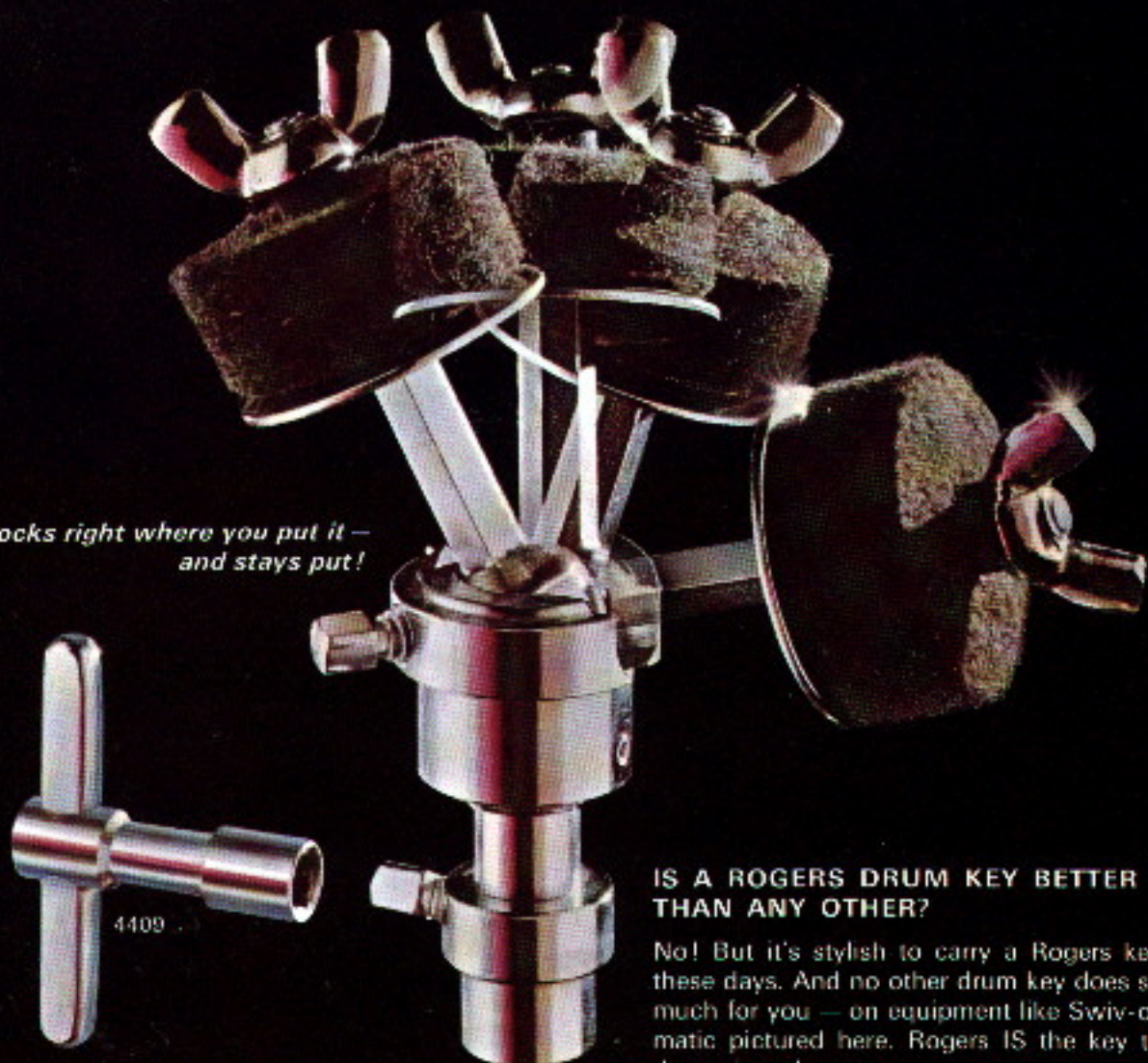

*Locks right where you put it —  
and stays put!*

### IS A ROGERS DRUM KEY BETTER THAN ANY OTHER?

No! But it's stylish to carry a Rogers key these days. And no other drum key does so much for you — on equipment like Swiv-o-matic pictured here. Rogers IS the key to drumming pleasure.

Model 4409. Fits standard drum rods and all Swiv-o-matic and Knobby equipment.



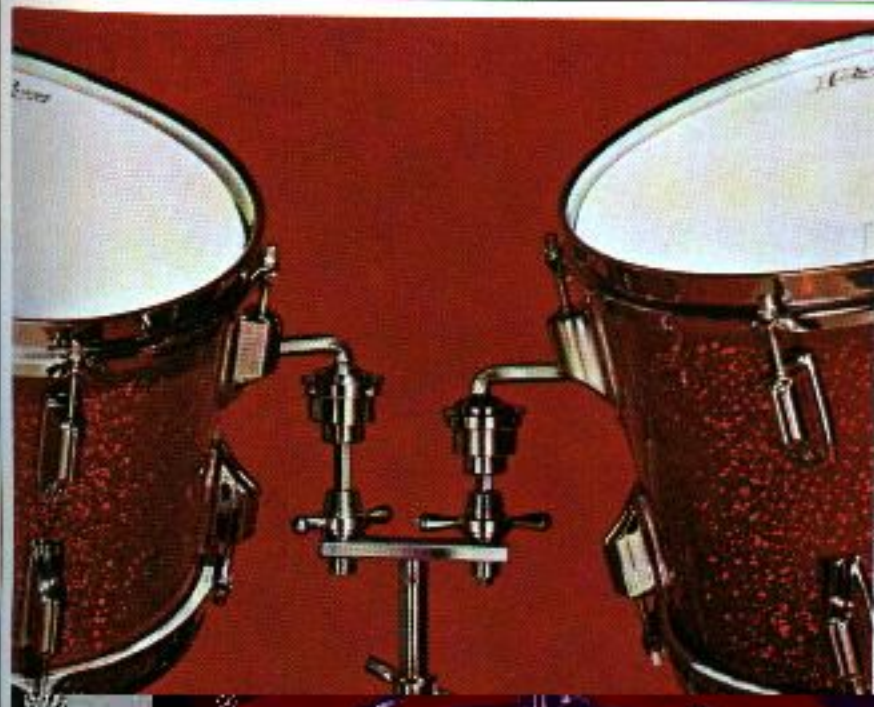

Tom-toms far apart



Tom-toms close together

## NEW SWIV-O-MATIC DUAL TOM-TOM HOLDER

366

There's no other like it. Amazing stability. Your tom-toms don't swing and sway! Here's the dual holder that provides unlimited adjustment, and still stays where you set it. Set it, forget it. Positions at any playable height and angle adjustment. Set tom-toms close together, spread apart, or any position in-between. Separate height adjustments permit you to keep drum heads level, even when using different size tom-toms.

### SWIV-O-MATIC TOM-TOM HOLDERS

All directional. Ball and socket with hex shafts for strength and elegance. Interchangeable. Fast set-up and knock-down. Special collet for positive locking. Two set screws can be switched into any of 4 holes for swivel lock. Standard drum key does it all. Fit all makes of drums. Highly polished, deluxe chrome plate.

**360 SWIV-O-MATIC SHELL MOUNT** for side mounting. Deluxe chrome plate finish. Fits all bass drums. Especially designed collet for positive locking.

**361 SWIV-O-MATIC SHELL MOUNT** for slightly off-center mounting. Deluxe chrome finish. Fits all bass drums.

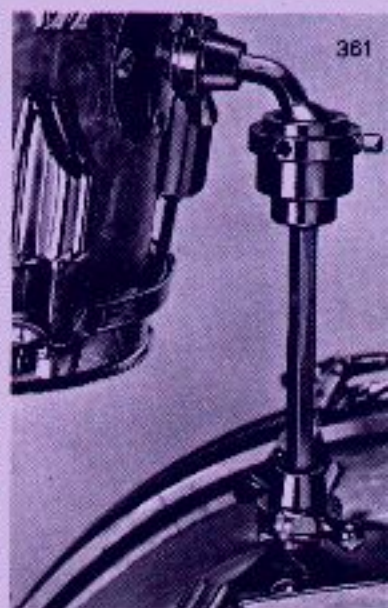

## CYMBAL STANDS, HOLDERS

### SWIV-O-MATIC DISAPPEARING INTERNAL CYMBAL HOLDERS

Mount your cymbal where you want it. Here's a Rogers mount and rod that's just right. Special no-twist hex steel rod, adjustable to height, disappears into drum shell. Stopbar prevents rod from dropping inside. Plate holder has collet assembly to assure positive non-slip grip.

**330** Straight mount, complete with collet plate assembly and felts.

**331** Angle mount, complete with collet plate assembly and felts.

### KNOBBY SHELL MOUNT CYMBAL HOLDERS

Round steel rod with "hex tip." Fits Rogers Swiv-o-Matic and all standard tilters. KNOBBY clamp has trench for never-slip grip. Adjust with any standard drum key.

**244** 7"

**245** 9"

**246** 12" (pictured)

**247** 15"

**248** 18"

### 252 TELESCOPIC KNOBBY SHELL MOUNT CYMBAL HOLDERS

At last, a telescopic shell mount cymbal holder with tilter which provides positive holding power for exact cymbal height placement.

**250** Same as 252, but without tilter.

### 325 SWIV-O-MATIC EXTENSION CYMBAL ARM

Add height and angle to cymbal holder. Special hex rod with all-directional SWIV-O-MATIC unit permits 360° placement. Cut-out allows 90° angle tilt. Fits Rogers and all other cymbal holders. Adjusts with standard drum key. Will also fit standard round rods.

### CYMBAL ARMS

With washer, felt and wing nut.

**254** 7"

**256** 9"

**257** 12"

**258** 15"

**259** 18" Not illustrated

### 4403 ROGERS "PRO"

#### Floor Cymbal Stand with Swiv-o-Matic Tilter

Complete portability and unique design combine to make this compact stand the choice of top musicians everywhere. SWIV-O-MATIC cymbal tilter for perfect non-slip cymbal adjustment. New base and legs to assure stability. Sturdy all steel construction and heavy chrome plating for tops in beauty and durability.

**4405** Same as above, without tilter. Cymbal felt and washer included.

### 1726 ROGERS "BANNER"

#### Flat base Cymbal Stand with tilter

A flat-base floor cymbal stand designed to hold the cymbals solidly and securely. Equipped with tilter. All-steel construction and heavy chrome plate. Cymbal not included.

### KNOBBY UNITS



**220** Utility model, with trench to accept 1/2" round rods.

**221** As above, but with larger trench to handle hex rods. (For use with Knobby tom-tom legs. Not illustrated.)

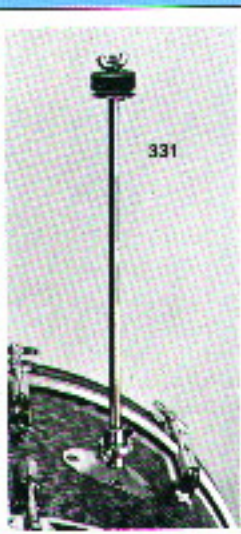
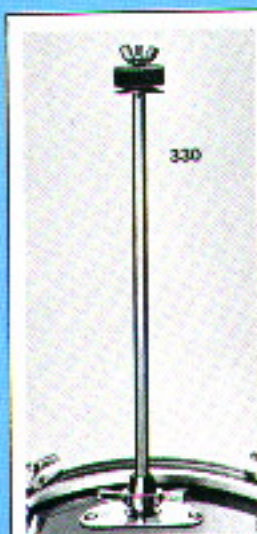
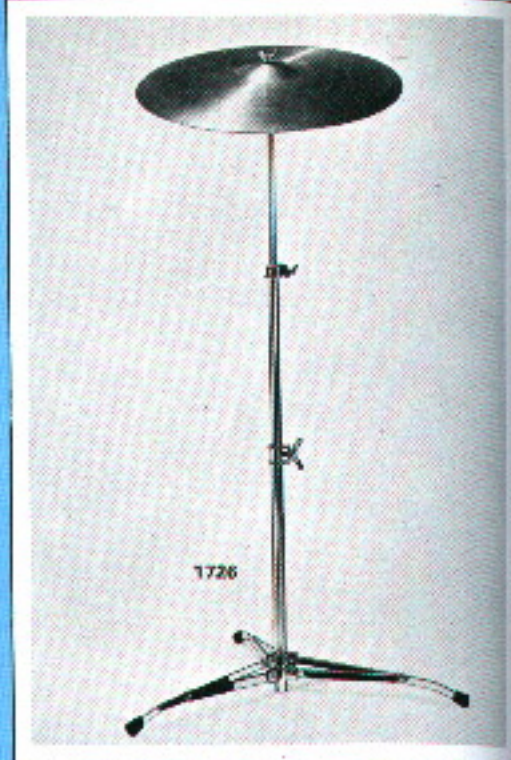

## DRUM STANDS

For every drumming need. Rugged all-steel construction. Chrome finish. Engineered for stability and balance desired by the most critical drummer. Height, angle and clamp arm adjustment. All fold compactly.



### 4012 GIANT

Heavy-duty clamping arms with reinforced Rogers leg design. Will accommodate 14" and 15" drums. Our most popular model. Preferred by the majority of drummers.

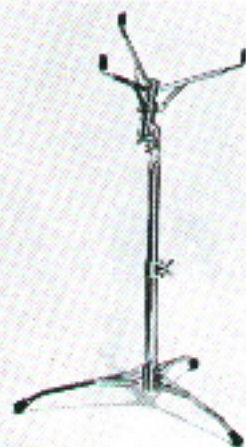

### 4018 SUPREME

Same as 4012 Giant, but with flat base.



### 4009 STA-TITE

A medium weight version of the 4012 Giant.

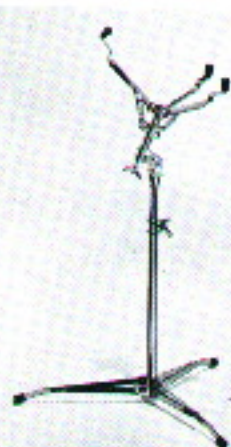

### 4008 CLIPPER

A medium weight version of 4018 Supreme.

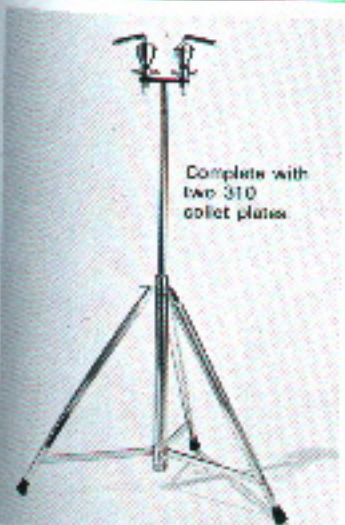

Complete with two 310 collet plates.

### 4005 DUAL TOM-TOM STAND

There's no other like it! Positions to any playable height. Drums stay where you put them. Tom-toms can be set far apart or close together. Adjusts so tom-toms are same height even when you use different sizes. SWIV-O-MATIC



### 4011 PRO

Medium in weight features the exclusive Rogers leg design for outstanding stability.



### 4010 BANNER

Flat base version of 4011 Pro model.



### 4019 SAMPSON

Heavy-duty double-legged tripod base. Extra sturdy clamping arms. Full height adjustment. Ideal for concert work.

### SWIV-O-MATIC COLLET PLATES

Fit all popular makes of drums. Chrome plated, complete with collet nose, bolts, nuts and washer for mounting.



310 Straight mount for tom-toms and bass drums.



311 Angle mount, for left or right mounting on bass drums.



312 Short angle, for slightly off-center mount. For left or right mounting on bass drums.

### 275 KNOBBY TOM-TOM LEGS

Shaped for maximum stability with wider perch. Hex legs are chrome plated and notched with position markers for even height adjustment. Set of 3 legs, 17 1/2", complete with Knobby units. Rubber tips included.

276 As above, but 20", set of 3. For use on 14x14 tom-toms.

277 Set of 4. Same as 275, for 18" or larger tom-toms.

### 4256 FLARE TOM-TOM LEGS

Gracefully curved legs with position markers for even height adjustment. Add beauty and greater stability to tom-tom. Chrome plated set includes 3 legs and mounts. Rubber tips included.

### 4416 STRAIGHT TOM-TOM LEGS

Sturdy steel round rods, chrome plated with rubber tips. Adjustable legs have position markers notched for accurate setting. Set of 3, including mounts. Rubber tips included.

### 363 CENTER SECTION OF SWIV-O-MATIC TOM-TOM HOLDER

Center section fits all Rogers collet plates. All-directional ball and socket with hex shafts.



### 313 COLLET NOSE

Fits all straight or angle collet plates.



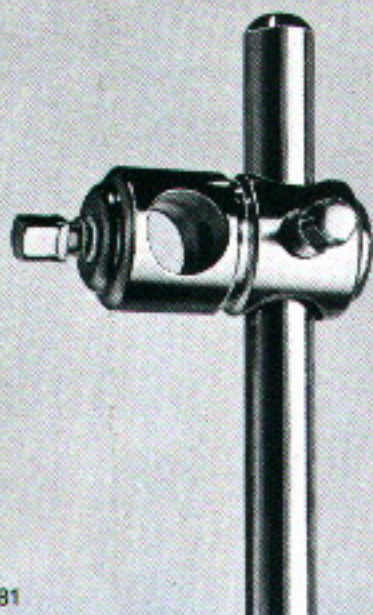

281

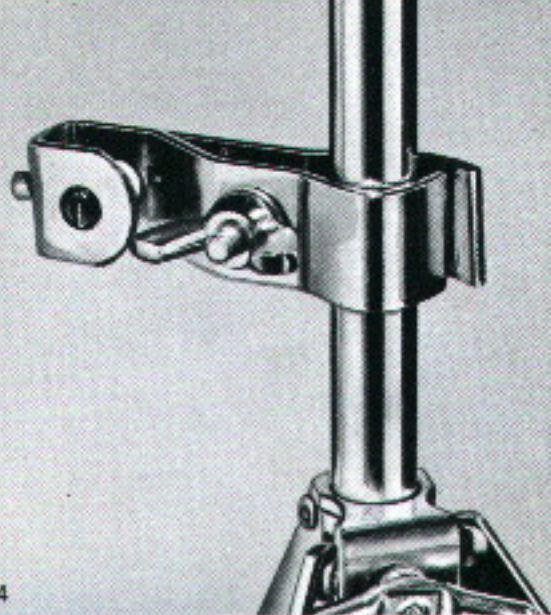

284

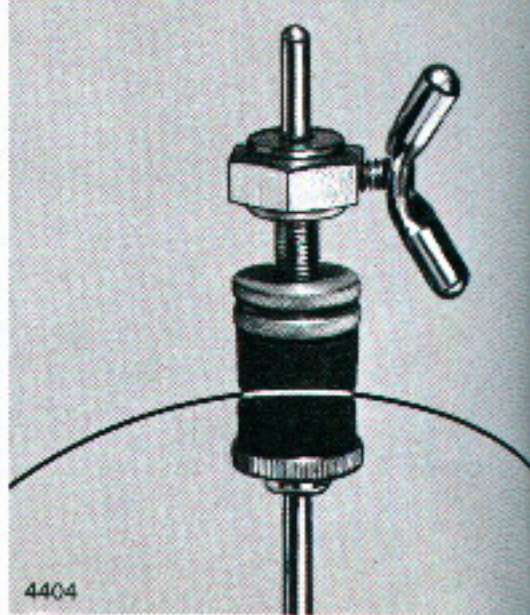

4404

**281 TWO-WAY CLAMP ATTACHMENT.** Ideal non-slip clamp for use on Rogers stick trays and adjustable cowbell holders.

**284 STICK TRAY CLAMP.** For use on hi-hat stick tray assembly.

**4404 HI-HAT CLUTCH.** Cymbal stays put! Fool-proof design will not vibrate loose. Permits cymbal to seat properly for correct cymbal sound allowing enough "play" so sound is not restricted or deadened.

**286 STICK TRAY.** Stop fumbling! Put the tools of your trade at your fingertips. Tray with mounting plate. Attaches to any type cymbal rod.

**287 TRAY ASSEMBLY.** Attaches easily to tom-tom leg. Includes tray with mounting plate, L-shaped rod and two-way clamp.

**288 TRAY ASSEMBLY.** Tray, complete with mounting plate, L-shaped rod and clamp to attach to hi-hat or cymbal stand.

**4399 JET HI-HAT.**

Newly designed direct pull with features never before offered in a popular price hi-hat. Unique one piece double spur base — won't skid.

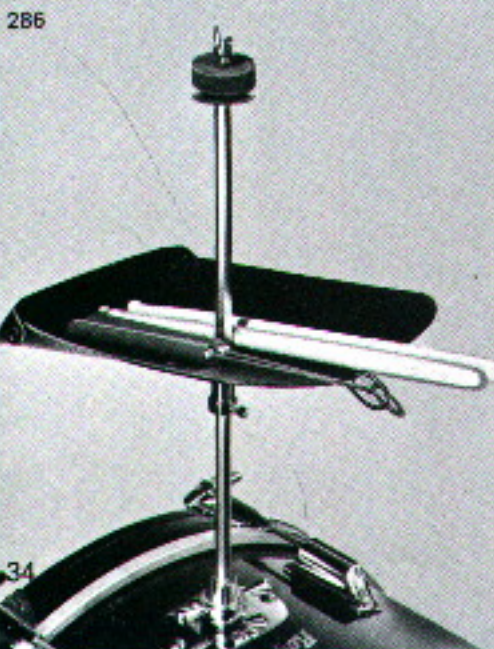
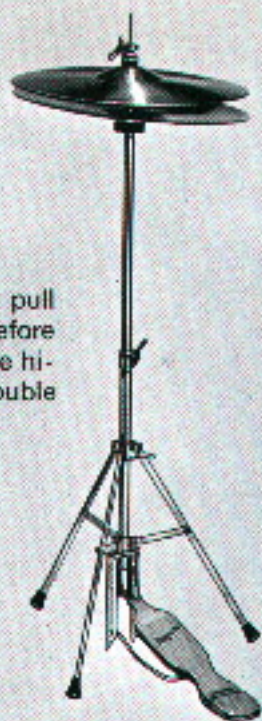

286

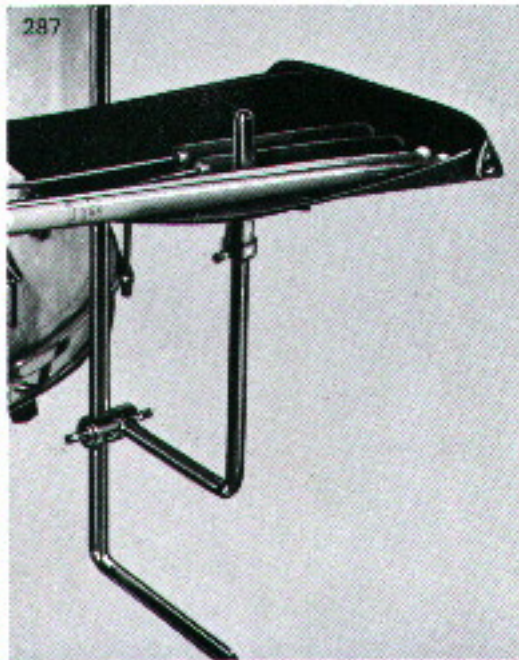

287

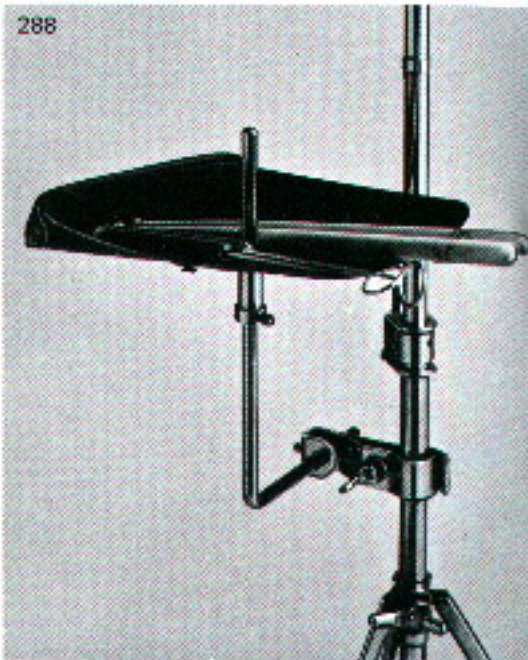

288

34

There's nothing like it!

## ROGERS SWIV-O-MATIC<sup>®</sup> HI-HAT

Count 8 reasons why this hi-hat is the 'hottest' in the land.

1. You get the 'chic' cymbal sound you want.
2. Top adjust cymbal clutch won't slip.
3. Cymbal tilter angles cymbal the way you like it and then **stays put!**
4. Non-slip 'U' clamp grips positively.
5. Spur and leg design seats firmly, won't creep.
6. Spring tension adjusts to your feel and cymbal size.
7. Twin direct-pull . . . balances, won't bind — gives you foot pedal smoothness.
8. Cushioned heel eliminates noise and clatter.

**4401** Hi-hat with hinged heel.

**4402** Hi-hat identical to 4401 but with 1-piece footboard.





399

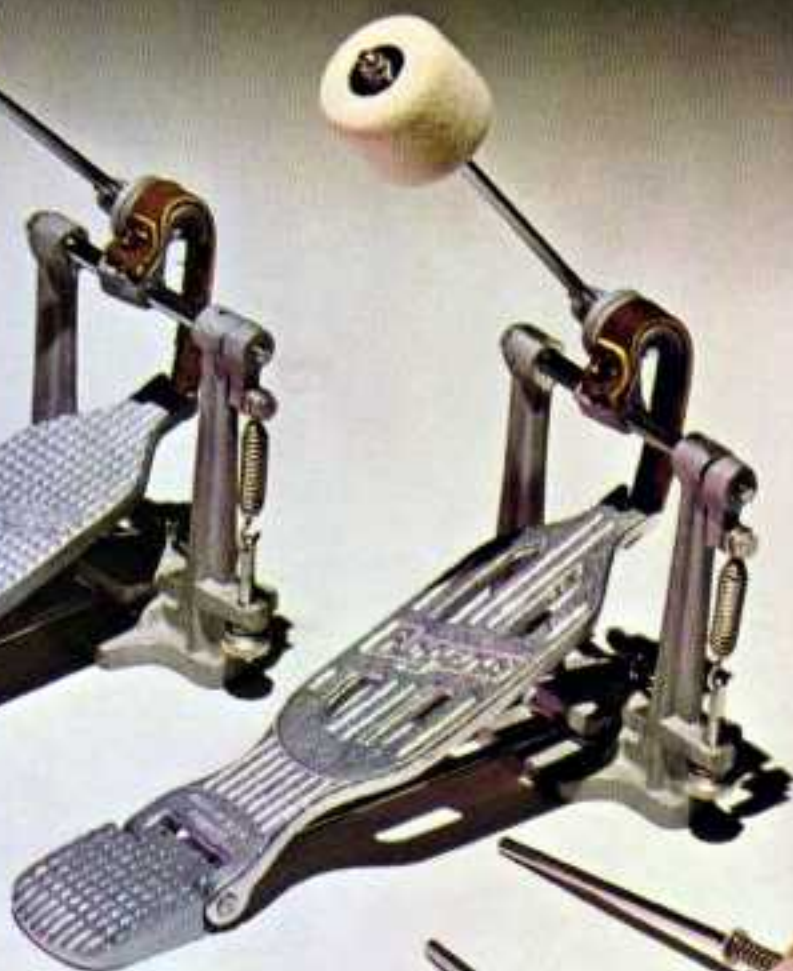

398

### 399 JET SPEED PEDAL

Smooth, long lasting performance at an economical price. New exclusive ratchet-type cam permits stroke adjustment without changing beater height. Fitted with jumbo self-aligning spring for dependable performance. Solid felt beater included.

### 398 ROCKET PEDAL

The "ROCKET" is rugged in construction and sensitive in touch. Fast action minimizes foot fatigue as a result of new design innovations (pat. pend.). Ratchet-type cam adjusts with standard drum key. Length of beater stroke can be changed without changing beater height. Needle-type bearing guarantees smooth action. Self-aligning, jumbo spring operates on bushing. Solid felt beater included. Two-piece footboard with hinged heel. Polished aluminum finish.



4422

4431

4420

4377

### PEDAL BEATERS

- 4422 Wood, for "bop" work.
- 4431 Lamb's wool
- 4420 Solid white felt
- 4377 2-way wood and felt for greater versatility and unique tonal effects. Spring and slot permit you to change from felt-to-wood, wood-to-felt without removing beater from pedal.

## Cut foot effort in half with feather action ROGERS SWIV-O-MATIC FOOT PEDAL.

Here is the fastest, smoothest pedal you've ever played. It also adjusts, attaches, assembles faster than any other pedal. If you don't believe it, try it!

Revolutionary new design cuts foot fatigue, adjusts to your natural position, gives smooth-fast action.

Check these features:

- Raise or lower beater action without changing length of stroke — so you get the sound you want from any drum.
- Adjust length of stroke without changing beater height.
- Swivel footboard so you play naturally, comfortably.
- Adjust spring tension from the top — easily, quickly, with specially positioned spring.
- New needle type bearings give maximum speed, smoothness.
- Built-in spurs prevent creeping of drums or pedal.
- Beater rod clamp is engineered for positive-permanent grip.
- Pedal folds up in single step into small compartment of trap case, assembles in seconds.
- Attachment to bass drum is unbelievably simple, won't slip, won't chew hoop, assumes same position every time.
- So simple, it's trouble-free for life.

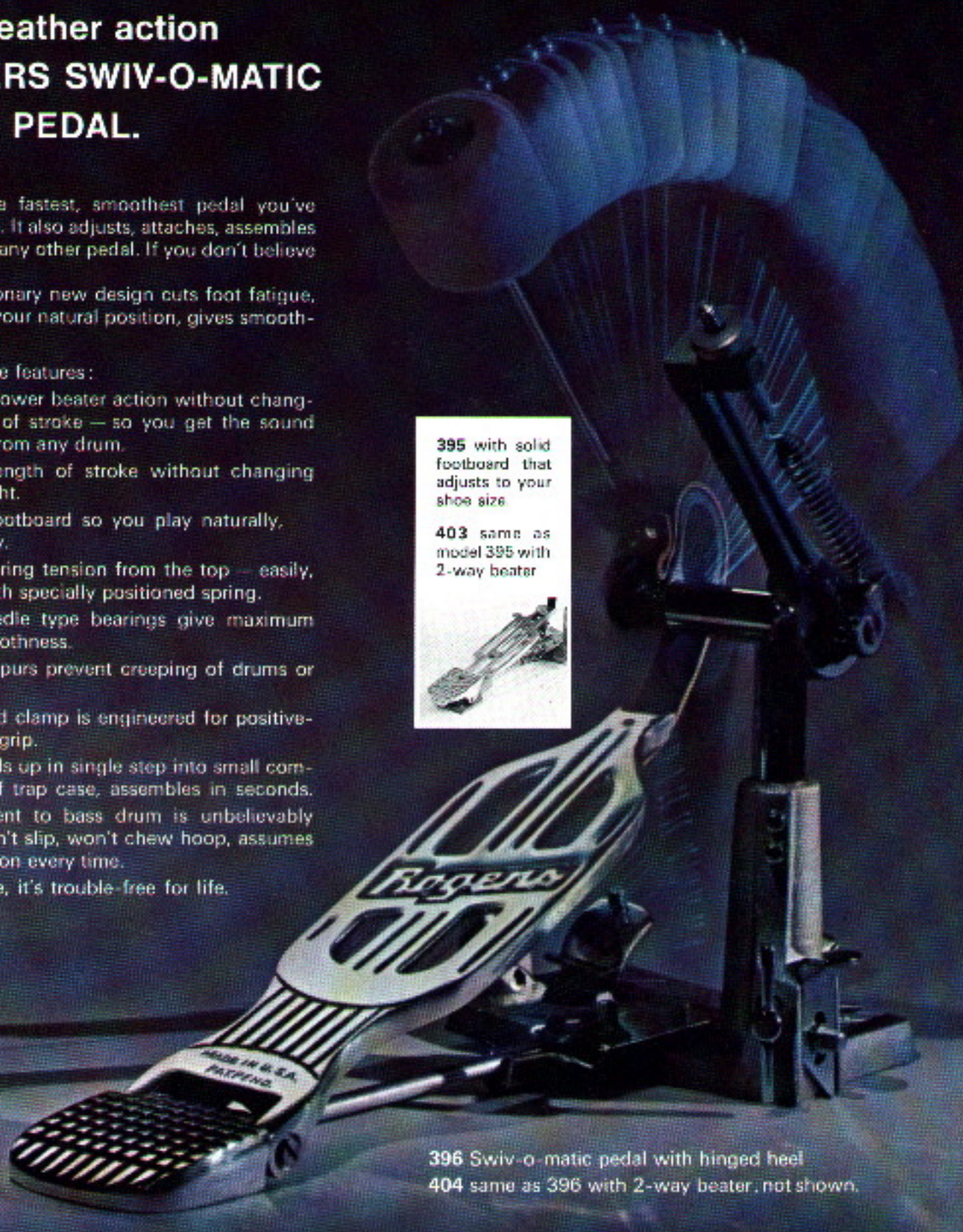

395 with solid footboard that adjusts to your shoe size.

403 same as model 395 with 2-way beater



396 Swiv-o-matic pedal with hinged heel  
404 same as 396 with 2-way beater, not shown.

### 390 SWIV-O-MATIC STRAINER

Patented design features. Eliminates constant readjusting, because spring loaded tension screw is held in fixed position, whether snares are in on or off position. Angular cut-away base allows strainer to pull snare cord at proper angle for precise action and alignment to satisfy the discriminating musical perfectionist. Roller mechanism provides fool-proof strainer action with full-throw-off. Fits all drums. Chrome plated. Complete with specially designed butt plate assembly.



389 Swiv-o-matic strainer for Dyna-Sonic

### 392 STA-TITE STRAINER

Designed with a minimum of moving parts for trouble-free performance, its moderate price belies its "top of the line" features. Spring loaded tension screw eliminates continual adjustment. Fits all drums. Chrome plated.



### 393 BANTAM STRAINER

Compactness and a minimum of moving parts make the Bantam an outstanding maintenance-free performer. Bantam's spring loaded tension screw keeps tension constant. Chrome plated. Fits all drums.



### ROGERS SNAPPY WIRE SNARES

12 Strand	4468	14"
16 Strand	4717	14"
	4718	15"
20 Strand	4457	14"
	4458	15"
	4465	16"

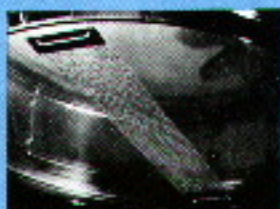

### SNAPPY WIRE SNARES FOR DYNA-SONIC ONLY

4466	for 14" snare drum
4467	for 15" snare drum

### GUT SNARES

4118	12 strands, light weight
4119	12 strands, heavy weight
9309	Fiber Butts

### DYNA-SONIC SNARE FRAMES

- 4723 with Snappy wire snare for 14" drum
- 4724 with Snappy wire snare for 15" drum
- 4725 with Nylon snare for 6 1/2"x14" concert drum
- 4726 with Nylon snare for 14" parade drum
- 4727 with Nylon snare for 15" parade drum
- 4728 with Gut snare for 6 1/2"x14" concert drum
- 4729 with Gut snare for 14" parade drum
- 4730 with Gut snare for 15" parade drum

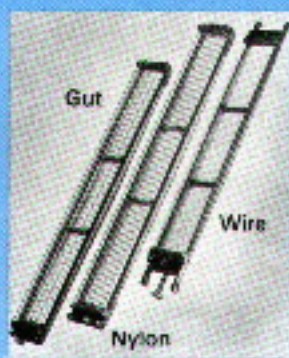

### 4200 SAMPSON THRONE

What more could you ask?

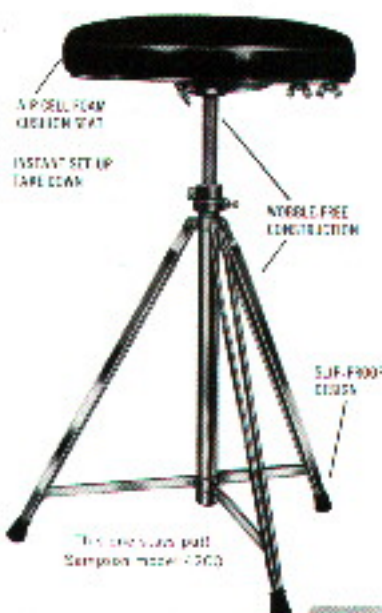

### 4201 THRONE HEEL REST

Clamps to double reinforced leg of 4200 model thrones. Chrome plated.



### 865 THRONE BACK REST

Not shown.

### 4206 SAMPSON THRONE WITH HEEL REST

For bass players and guitarists. See sketch below.



The Rogers Sampson Throne works beautifully for bassists, guitarists, pianists, percussionists ... perfect seat for any musician.



## 4200 ROGERS SAMPSON THRONE

**SIT IN COMFORT!** This throne's got it. New air-cell foam cushion seat means you can sit for hours — and sit some more. It's mattress firm, just right for playing comfort hour after hour.

**SIT SECURE!** It's wobble free! No more worry about your seat slipping, moving. You can move all you want. **This throne stays put.** Special sure-grip rubber tips prevent creeping.

■ New 100% slip-proof positioning clamp keeps your seat where you set it. You can twirl about without changing your height adjustment.

**SIT WITH CONFIDENCE!** This throne's built to last — and keep its stability. You can see and feel the rugged construction. Solid An alloy seat chassis, double reinforced legs and braces, special case-hardened steel inserts, extra machining guarantee solid performance.



### 4200 ACCESSORY THRONE

Does double duty. This comfortable padded throne solves the problem of storing traps. Holds stands and accessories. Standard 24" high. Specify finish. Marine pearl illustrated.

3180 Zipper throne cover  
1480 Fibre case for throne

## CONCERT TOM-TOMS

Increasingly popular with modern percussion ensembles. Set of four, single head tunable tom-toms. Mounted on Rogers dual tom-tom stands. Sizes 15", 14", 13", 12". Available in choice of lacquer or pearl finishes.

- 148** Set of 4 with stands, lacquer
- 149** As above, pearl finish
- 4005** Dual Swiv-o-matic tom-tom stand

Pearl	Lacquer
<b>141</b> 12"	<b>140</b> 12"
<b>143</b> 13"	<b>142</b> 13"
<b>145</b> 14"	<b>144</b> 14"
<b>147</b> 15"	<b>146</b> 15"

Specify finish.

Finish Shown:  
*blue and silver lacquer*



## ORIENTAL TEMPLE BLOCKS

- 4876** Complete set of five, less stand.
- 4871** 4 1/4"
- 4872** 5"
- 4873** 5 1/2"
- 4874** 6"
- 4875** 6 1/2"
- 767** Temple Block Floor Stand.

Hand carved Temple Blocks, colorfully finished in lacquer. May be purchased separately or in complete set of five.

## CONCERT TRAP TABLE AND STAND

Foam padded table top measures 24x18" with Rogers exclusive reinforcing frame mount. Holds traps for quick use in band or orchestra. Heavy duty chrome stand folds for easy packing. Complete height adjustment.

- 768** Trap Table and Stand



## LATIN TIMBALES Humberto Morales Model

The authentic Latin sound has never been more perfectly duplicated than in Rogers 'Humberto Morales' model Timbales. A new acoustic shell design makes these unquestionably the world's best. Constructed with the same care and precision as the renowned Rogers Dyna-Sonic drums. Timbale sizes 6½x13 and 6½x14. Produces the genuine Latin-American sound for modern rhythms.

Shells are of special alloy brass, noted for its acoustic properties. Each is highly polished to a mirror lustre. Both skin head and plastic head models come with wrapped counter hoops. Cowbell holder assembly and Timbale sticks included. Steel stand is of improved sturdy design, remaining upright with only one Timbale during set-up or knock-down. Positively wobble-free. No other like it. Chrome plated.

**4904** Timbales. Brass shells, skin heads.

**4905** Timbales. Brass shells, plastic heads.

**4906** Timbales. Chrome plated brass shells, skin heads.

**4907** Timbales. Chrome plated brass shells, plastic heads.

Chrome plated stand and timbale sticks included with each set.

**4908** Timbales stand with cowbell holder.

**4902** Zipper Cover (carries both Timbales.)

**4852** Timbale sticks (pair)



*HUMBERTO MORALES—Recognized as one of the original and foremost authorities on Latin-American music. Noted for distinctive Timbale stylings, Morales plays Rogers.*

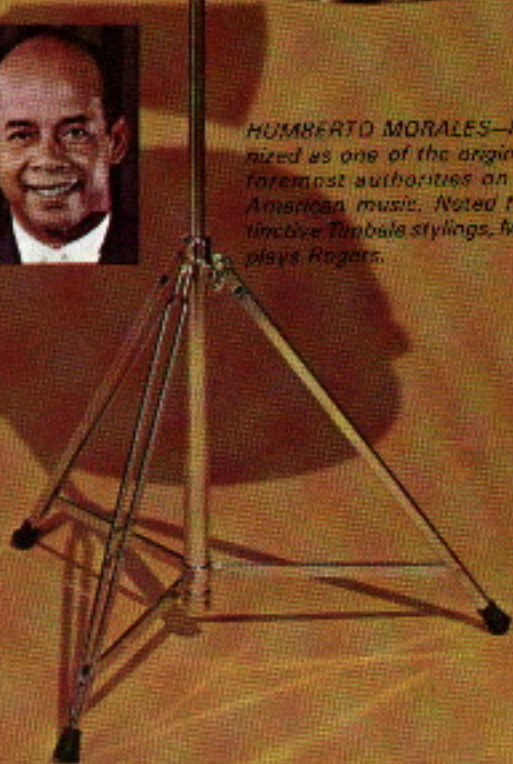

## TUNABLE BONGOS

Professional quality. Lustrous pearl finishes match Rogers Holiday drums. New connector mount between bongos gives instant mounting on any floor cymbal stand.

Bongos have shell depth of 5½" with head diameters of 6" and 8". Each head is tunable with standard drum key. Laminated shells are reinforced for the high tension required to achieve authentic and precise bongo sounds. Flanged hoops and self-aligning tension lugs. All hardware in gleaming chrome. 4050 supplied with skin heads.

**4039** Available in choice of pearl finishes — see page 85.

**4405** Floor Stand, wide base, chrome finish.

**321** Bongo Tilter Adapter. Not shown.



Finish shown: blue onyx



## NEW ROGERS TIMBALE STAND

- Sturdy pin and slot mount. Timbales slide on and off easily. Eliminates lateral movement.

- Exclusive tilting adjustment. Set your timbales at any playing angle — they stay put.

- 'Up-front' cowbell holder. Close but not over the timbale head. Complete up and down — back and forth adjustment.



4908

### 4609 MAMBO BELL

The ultimate in sound and quality.

Specifically designed with the sound required for outstanding mambo tone. Creased design provides sharper accents. A Rogers exclusive. 9½" long including loop.

### 4610 CHA-CHA BELL

Produces sharp, clear and ring-free sound. Rogers exclusive crease design provides sharper accents. 6" long.

4609

4610



**119 METAL TUBOS (Chocolo).** Produces a "swishing" sound when shaken. Metal tube with seeds enclosed and sealed at both ends. Large size, 13¾" long.

**117 WOOD GUIROS.** Hand made of natural woods. Carefully finished and polished. Evenly spaced deep grooves provide clear tone and resonance. Complete with scratcher.

**122 WOOD SHAKER.** A popular rhythm instrument with excellent tone. Highly polished natural wood, with hand painted picture design.

**4961 CLAVES.** Large deluxe model. Hand-turned, lacquered and polished. High pitch, professional quality.

**TUNED COW BELLS.** Heavy alloy construction, fully welded seams. In copper or chrome finish. Height includes loop.

COPPER		CHROMED	
4786	3¾"	4781	4¾"
4787	4¾"	4782	5¾"
4788	5¾"	4783	5¾"
4789	5¾"	4784	6¾"
4790	6¾"		

**ZIL BEL COW BELLS**  
Polished Chrome  
4604 6" 4606 4¾"

42

119

117

122

4961

Copper

Chrome

4604

4606

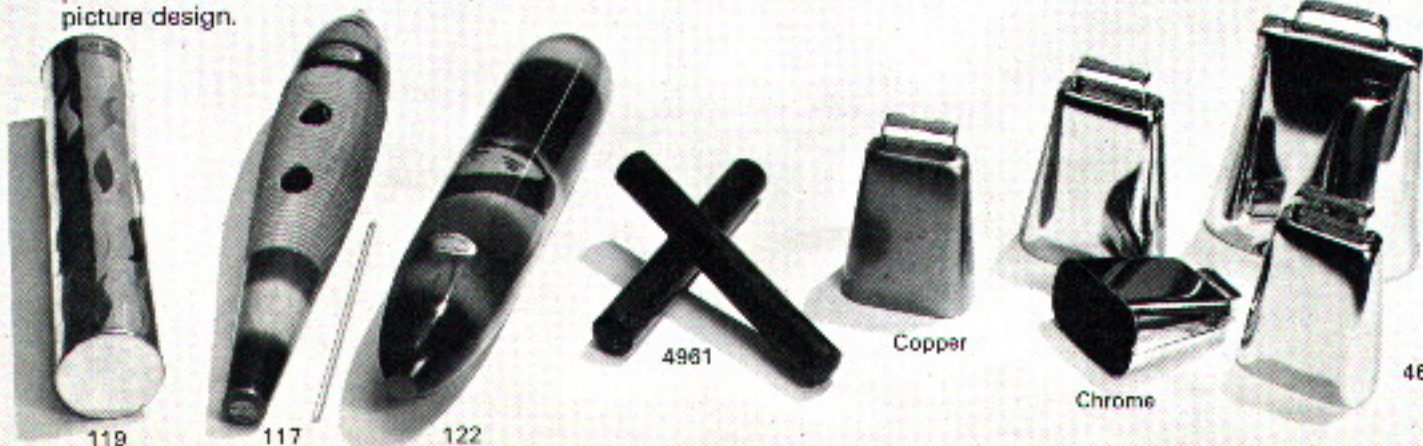

## MARACAS

Hand-made Mexican wood maracas. Polished to high lustre. Excellent tone and clarity.

- 4957 Natural finish with hand-painted native scenes.  
4956 Hand-carved designs in brilliant color. Not shown.



4957

## 4896 TUNABLE PROFESSIONAL CONGA

Genuine mahogany in dark finish with metal bands. Heavy tension lugs. Mule skin head. Best professional quality.

Size: 30" high, 11" diameter.



## WOOD BLOCKS

Professional quality. Slotted top and bottom. Fit standard holders.



- 4816 6 1/2" medium  
4817 7 1/2" large

## 7428 WOOD BLOCK HOLDER

Hoop mount. Holds any size wood block.

## 282 ADJUSTABLE WOOD BLOCK ATTACHMENT

Attaches to any round or hex rod. Easily adjustable to any playable height or position.

## 4813 COMBINATION HOLDER

Holds cow bell and wood block. Mounts on bass drum hoop. Combination of 4656 cow bell holder and 282 wood block attachment. Chrome plated.

## 280 COW BELL HOLDER ASSEMBLY

Can be attached to any round or hex rod. Eliminates hoop mounting. Adjustable to height or angle desired. Chrome plated.

## 4658 PARADE DRUM COW BELL HOLDER

Mounts easily on Parade Drum shell. Places cow bell in easy-to-reach position. Chromed.

4656 STA-TITE COW BELL HOLDER  
With 6" post and "U" clamp. Mounts on bass drum hoop. Chrome plated.

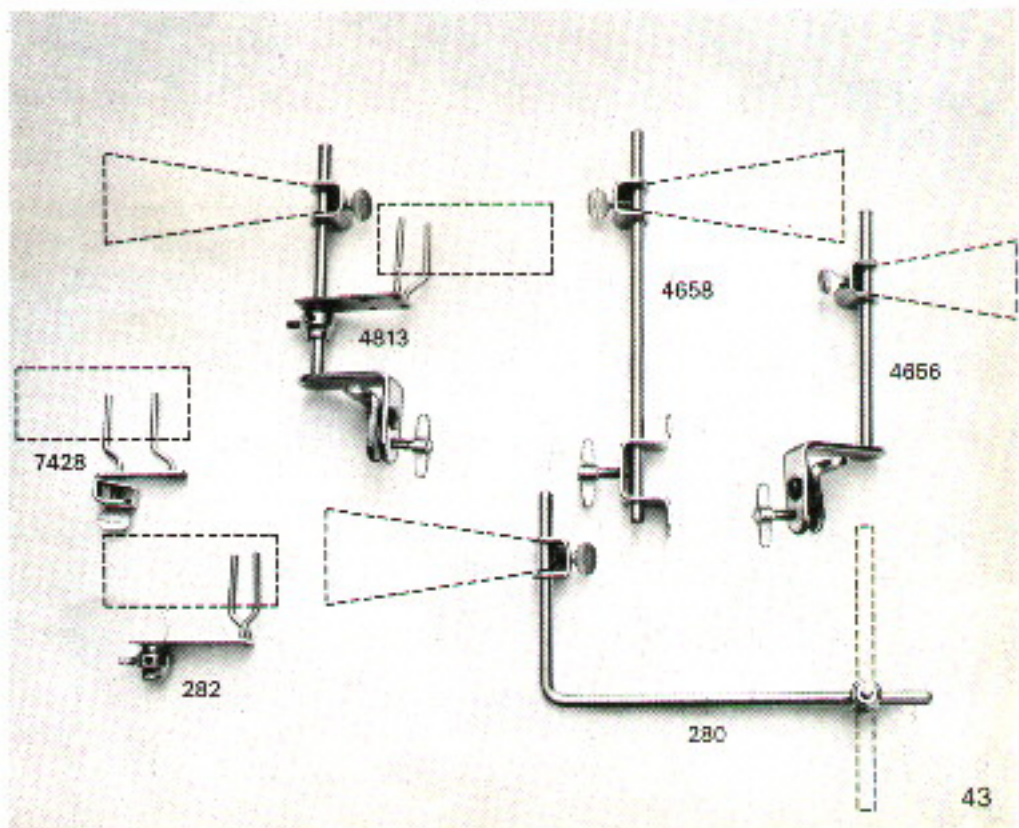

## ROGERS TAMBOURINES

Professional quality tambourines, with solid rims, attractively finished. Superior tone quality with genuine nickel-silver jingles.



4732

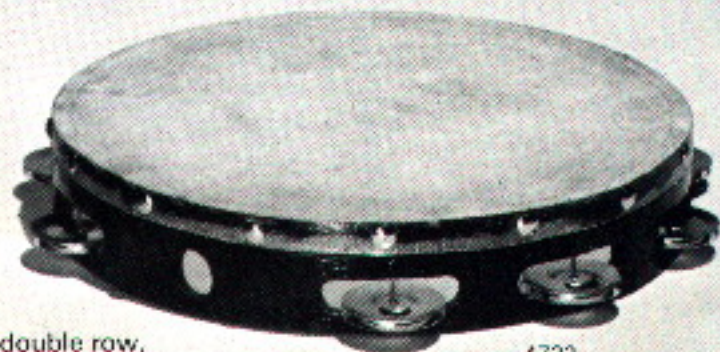

4722

- 4732 10" double row,  
17 pr. jingles  
4722 10" 9 pr. jingles  
4721 8" 6 pr. jingles  
4720 7" 5 pr. jingles

### SLEIGH BELLS

Ever popular for many descriptive musical pieces. For contemporary musical sounds.

- 567 13 sleigh bells on handle  
568 25 sleigh bells on handle  
566 12 sleigh bells on strap, not shown

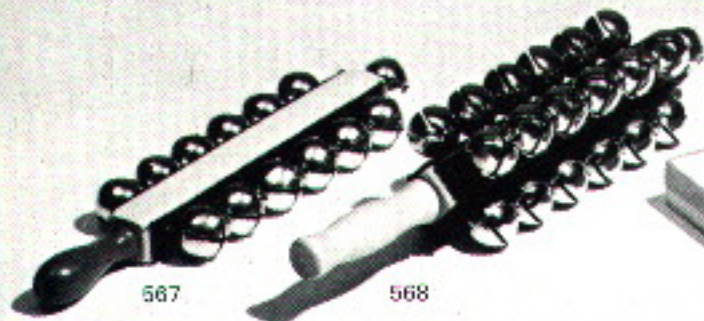

567

568

### 507 CASTANET MACHINE

Ideal for school band and orchestra work. Free-moving design provides instant and trouble-free response. Played with fingers or soft mallets. Rosewood mounting block and plastic castanets for the authentic sound.



507

### CASTANETS

Authentic Spanish sound. Professional style castanets. Resonant clappers for outstanding resonance and tone quality. Ebonized finish.

- 500 Hand Castanets, set of 2 pairs with instruction book.  
505 Single pair Castanets on handle.  
506 Double pair Castanets on handle.



500

506

505

### 560 DOUBLE RATCHET

Made of top grade hardwoods with metal sides for lasting durability.

### 4731 SAND BLOCKS

Ideal for unique sound effects.

### 116 SLAPSTICK

Controlled by strong spring to achieve proper "whip" effect for sharp cracking sound.

### 302 AMERICAN SONG WHISTLE

All-metal, 12" long. Easy slide action. Chrome plated. Durable construction for long life.

### 10 ACME WHISTLE

Standard Model. World's finest professional whistle. Loud and powerful. Nickel-plated brass. 2 3/4" long.

### 11 ACME SIREN

Especially sensitive, producing exceptionally clear tone. Made of quality nickel-plated brass. 4 3/4" long.

### TRIANGLES

Made of top grade steel to achieve rich clear sound with full projection. Plated to prevent rusting. Beater included.

- 4713 Size 5" 4715 Size 8"  
4714 Size 6" 4716 Size 10"  
4711 Triangle Clip Holder

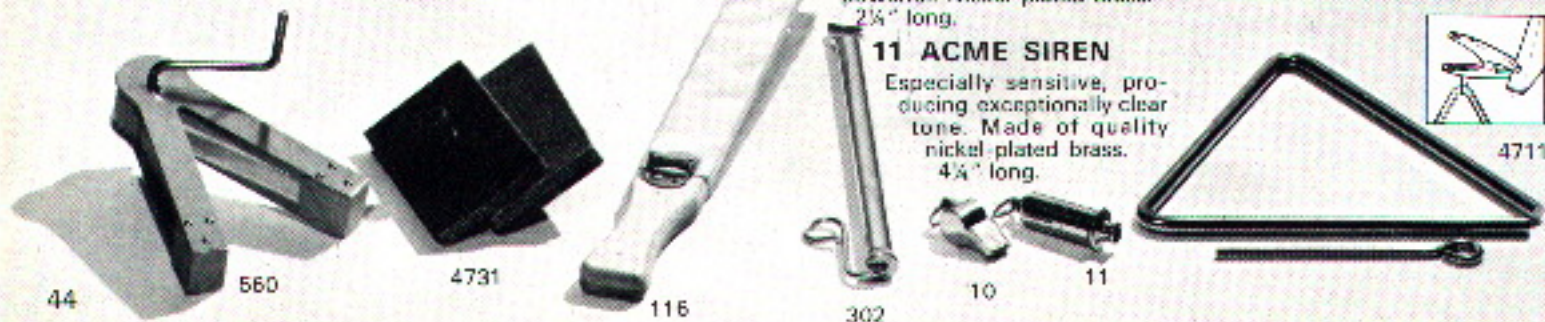

44

560

4731

116

302

10

11

4711

## ROGERS DRUM COVERS



### NAUGAHYDE

Here's the best in cover protection. Rugged fabric-backed deluxe Naugahyde vinyl. Long-wearing material. Black "leather like" surface. Heavy duty triple-sewn zippers and welt bindings.

#### SNARE DRUM COVERS

- 3364** Shell size 5x14  
**3365** Shell size 6½x14

#### TOM TOM COVERS

- 3366** Shell size 8x12  
**3367** Shell size 9x13  
**3368** Shell size 14x14  
**3369** Shell size 16x16

#### DANCE BASS DRUM COVERS

- 3370** Shell size 14x18  
**3371** Shell size 14x20  
**3372** Shell size 14x22

### CYMBAL CARRYING BAGS

"Puff"-style design accommodates cymbals with or without hand-grips. Removable, adjustable clip-on shoulder straps. Heavy-duty luggage handles. Long, easy-sliding zipper. Rugged Naugahyde.

- 4273** For 18"  
**4277** For 22"



### MACKINTOSH

Made of the highest grade, extra strong Cover (Mackintosh). Waterproofed, flannel lined. Finest workmanship. Reinforced seams. Designed to fit. Equipped with strong Zipper Fastener.

#### SNARE DRUM COVERS

- 3112** Shell size 5x14  
**3113** Shell size 5½x14  
**3114** Shell size 6½x14  
**3115** Shell size 8x15

#### TOM-TOM COVERS

- 3122** Shell size 8x12  
**3123** Shell size 9x13  
**3125** Shell size 14x14  
**3128** Shell size 16x14  
**3127** Shell size 16x16  
**3129** Shell size 16x18

#### PARADE and TENOR COVERS

- 3161** Shell size 10x14  
**3162** Shell size 10x15  
**3163** Shell size 12x15  
**3164** Shell size 12x16

#### DRUM THRONE COVER

**3180** for 4208 Throne

#### BASS AND SCOTCH COVERS

- 3140** Shell size 14x18  
**3141** Shell size 12x20  
**3142** Shell size 14x20  
**3143** Shell size 12x22  
**3144** Shell size 14x22  
**3146** Shell size 12x24  
**3147** Shell size 14x24  
**3148** Shell size 8x26  
**3149** Shell size 10x26  
**3151** Shell size 14x26  
**3152** Shell size 8x28  
**3153** Shell size 10x28  
**3155** Shell size 14x28  
**3156** Shell size 14x30  
**3157** Shell size 16x32  
**3158** Shell size 16x34  
**3159** Shell size 16x36  
**3160** Shell size 18x40

Sizes not listed supplied to special order.



For cases see page 60.

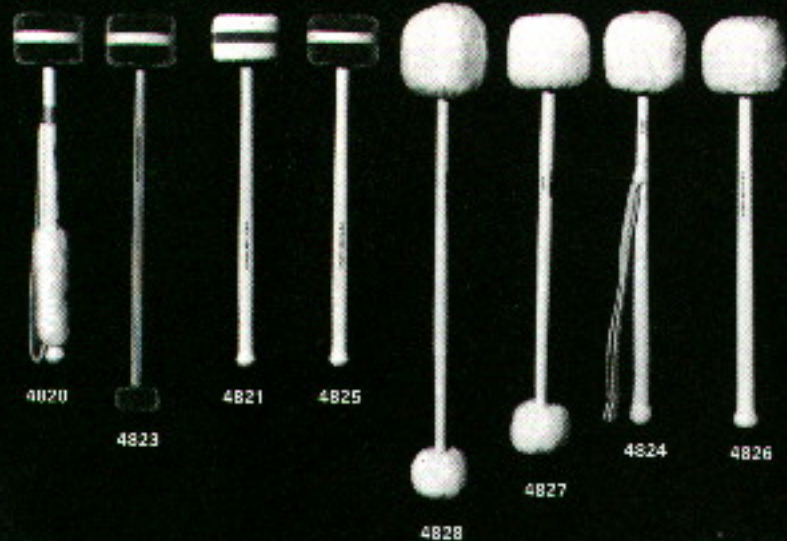

## ROGERS CONCERT BASS DRUM BEATERS

### FELT BALL

- 4820** 3-ply felt ball with white center. Lamb's wool grip, leather loop. Length 12 $\frac{1}{2}$ " overall; head diameter 2 $\frac{1}{2}$ ".
- 4823** Double end model. 3-ply grey felt, with white center. Length 14" overall; top head diameter 2 $\frac{1}{2}$ "; bottom head 1 $\frac{1}{2}$ ".
- 4821** White felt, 3-ply, with green center. Length 12 $\frac{1}{2}$ " overall; head diameter 2 $\frac{1}{2}$ ".
- 4825** Grey felt, 3-ply, with white center. Length 12 $\frac{1}{2}$ " overall; head diameter 2 $\frac{1}{2}$ ".

### LAMB'S WOOL BALL

- 4828** Lamb's wool, double end, Concert Model. Length 17"; top head diameter 3 $\frac{1}{2}$ "; bottom head 2 $\frac{1}{2}$ ".
- 4827** Lamb's wool, double end. Length 15 $\frac{1}{2}$ " overall; top head diameter 3". bottom head 2".
- 4824** Lamb's wool, single end, with leather loop. Length 15" overall; head diameter 3".
- 4826** Lamb's wool ball, single end. Length 15" overall; head diameter 3".

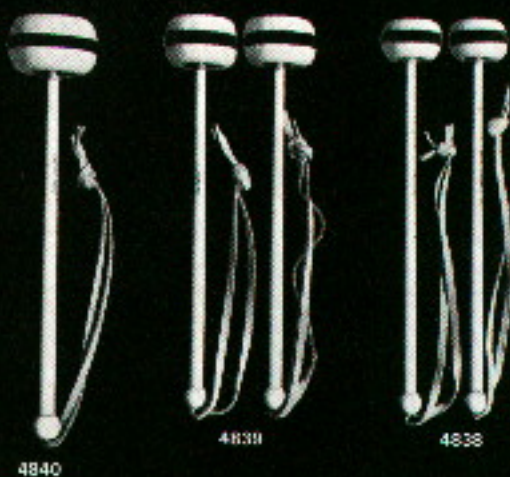

## GREAT DANE FIBER GLASS BEATERS

High quality felt heads reinforced with cork cores for retention of shape. Tapered fiber glass handles for durability and strength.

- 4840** Bass Drum Beater — Large 2 $\frac{1}{2}$ " head, overall length — 13 $\frac{1}{2}$ ".
- 4839** Pair Scotch Bass Drum Beaters — 2 $\frac{1}{4}$ " head, overall length — 12".
- 4838** Pair Tenor Drum Beaters — 1 $\frac{1}{2}$ " head, overall length — 11 $\frac{1}{2}$ ".

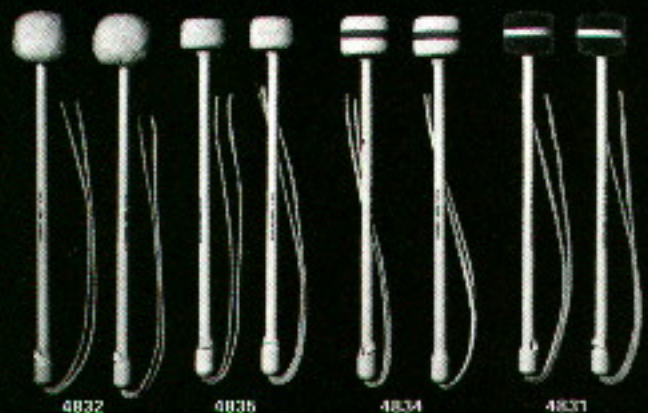

## ROGERS TENOR DRUM BEATERS

- 4832** Lamb's wool ball. Length 13", head diameter 2".
- 4835** Solid white felt ball. Length 12"; head diameter 1 $\frac{1}{2}$ ".
- 4834** White felt, 3-ply, with green center. Length 12 $\frac{1}{2}$ "; head diameter 1 $\frac{1}{2}$ ".
- 4831** Grey felt, 3-ply, with white center. Length 12 $\frac{1}{4}$ "; head diameter 1 $\frac{1}{2}$ ".

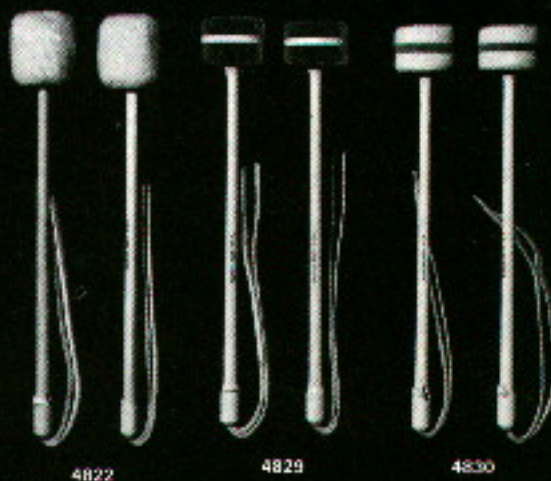

## ROGERS SCOTCH DRUM BEATERS

- 4822** Lamb's wool ball. Length 14 $\frac{1}{2}$ " overall; head diameter 2 $\frac{1}{2}$ ".
- 4829** Grey felt, 3-ply with white center. Length 14" overall; head diameter 2 $\frac{1}{2}$ ".
- 4830** White felt, 3-ply with green center. Length 14 $\frac{1}{2}$ " overall; head diameter 2 $\frac{1}{2}$ ".



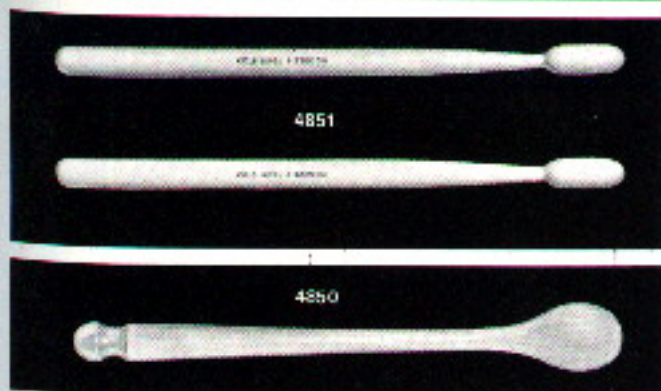

4851

4850

**4851 SOLID WOOD TENOR DRUM STICKS**

Best hickory wood with clear lacquer finish. In pairs.

**4850 SOLID WOOD BASS DRUM BEATER**

Made from fine selected hardwood. Clear lacquer finish.

**6084 T-BOOM TAM-TAM and BASS DRUM BEATER**

This entirely new concept in beaters features a multi-faceted head that provides the artist with a remarkably wide range of sound producing materials and surfaces. Instructions for various technical applications included.

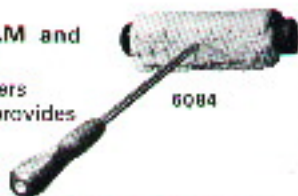

6084



4437

4679

4678

4677

**ROGERS LEG RESTS**

**4437 SPRING TENSION**

Has tension hinge-spring to prevent slipping when in use. Exclusive "T" clamps slip over drum tension rods instantly without dismantling. Holes in curved band can be used for leg strapping. Chrome plated.

4434 Same as 4437 but nickel plated. Not shown.

**4679 SPRING TENSION SHELL MOUNT**

Same construction as 4437 Rod-Mount model, but equipped with large rigid steel plate to fasten directly to shell. Supplied with bolts, nuts, and washers. Chrome plated.

**4678 SWIV-O-MATIC SHELL MOUNT**

Specifications and features are same as 4677 Rod Mount. Supplied with heavy steel plate, complete with all necessary bolts, nuts, and washers. Chrome plated.

**4677 SWIV-O-MATIC**

Most practical, most efficient leg rest ever designed. "T" clamps slip over drum tension rods without dismantling. All directional ball socket with cut-out permits 90° angle adjustment. Curved band mounts off-center for more comfortable fit and added leg comfort. Holes in curved band can be used for leg strapping. Chrome plated.

**999 BAND CYMBAL HOLDER**

Holds cymbal securely to bass drum.

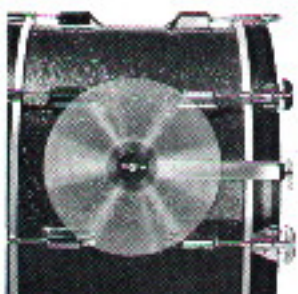

**4198 HI-STEPPER**

For parade and tenor drums. A popular concept in carrying a drum for precision marching and rudimental playing. Allows extreme maneuvers like fast runs, side bends, dances, and runs. No bounce or swing around. Even weight distribution.



**4439 MUFFLER**

Professional quality muffer with spring tension screw. Permits full adjustment to any desired pressure and angle. Large metal disc with high grade felt pad. Chrome plated.

**NYLON SLINGS**

Made of white nylon. Tops in strength and durability. Practical and neat. Wipes clean in a jiffy with soap and water. Will not stretch, slip or shrink.

4920 Parade drum sling, white nylon.

4921 Bass drum harness, white nylon.

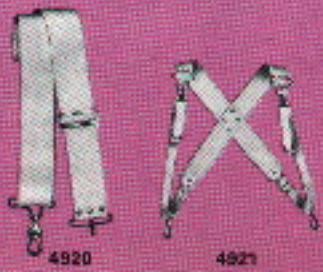

4920

4921

**WEB SLINGS**

Fully adjustable, 2" wide webbing.

4447 Parade drum sling. Not shown. Same style as 4920 but in white webbing.

4453 Bass drum harness. Not shown. Same style as 4921 but in white webbing.

4460 Standard parade drum sling - white webbing.

4451 Bass drum sling - white webbing.

4464 Sam Brown Belt model harness - white webbing.



4460



4464



4451



**1604 BASS DRUM ANCHOR**

Anchor prevents creeping. Reversible rubber or pointed tips. Chrome plated.



**5882 SPUR STOP**

Designed to place under drum spurs. Protects rugs and floors.



**9287 INTERNAL TONE CONTROL**

Fits snare or parade drums and tom-toms.



338



340

**INTERNAL DISAPPEARING SPURS**

All steel construction. Hexagon rods fit a broached collet plate that prevents turning. Positive grip assured. Stop-bar keeps rods from dropping inside drum. Rubber tips. Deluxe chrome.

338 for 18" and 20" Bass Drum.

340 for 22" and 24" Bass Drum.

## ROGERS DRUM STICKS

Balanced drum sticks made from the finest thoroughly seasoned hickory. Proportioned, finished and balanced to professional "feel".



### ROGERS STAR STICKS

Our best sticks. Top professional quality in the length and shapes picked by the nation's leading drummers.

6100 (RB*) Sticks	15 3/4" long
6110 (LB*) Sticks	16 1/2" long
6111 (CC*) Sticks	16" long

6100

6110

6111

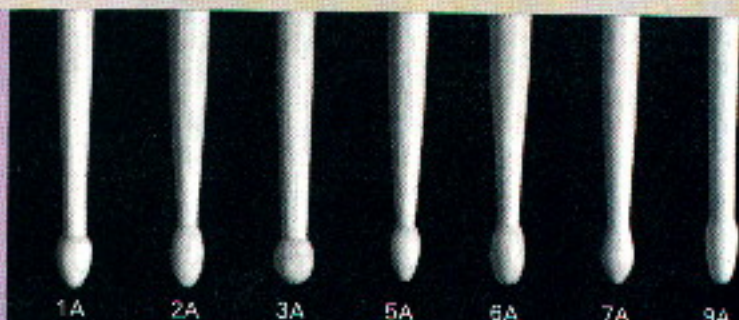
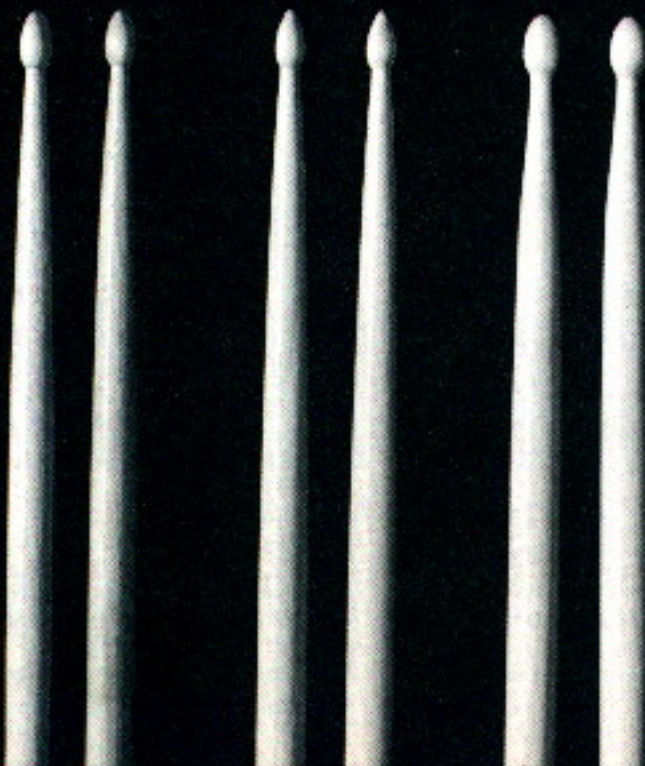

### DANCE and ORCHESTRA MODELS

6101	16 3/4" long, 1A
6102	16" long, 2A
6103	15 1/2" long, 3A
6104	16 1/2" long, 5A
6105	15" long, 6A
6106	15 1/2" long, 7A
6107	15 1/2" long, 9A
6108	15 1/2" long, 11A

### BAND and ORCHESTRA CONCERT MODELS

6112	16 1/2" long, 1B
6113	15 1/2" long, 2B
6114	16 1/2" long, 5B

### PARADE MODELS

6115	16 1/2" long, 1S
6116	17" long, 2S
6117	17" long, 3S

### NYLON TIP STICKS

Ideal for cymbal work. Finest grade hickory tipped with special nylon tip that outlasts wood. Produces superior brilliant cymbal sound.

6118	16", 2A model	6120	15", 6A model
6119	16 1/2", 5A model	6121	15 1/2", 7A model

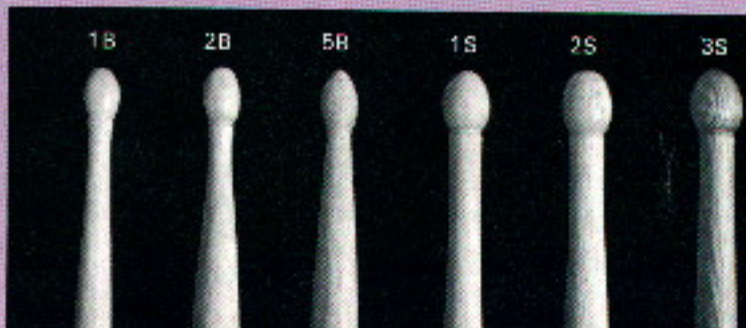

Contour Shape a Rogers exclusive on 6100 RB\* model. Superior stick feel, superior control.

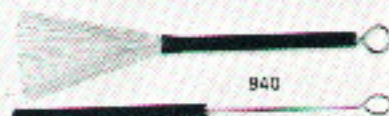

**940 WIRE DRUM BRUSHES.** Rubber covered aluminum tubing. Loop end. Narrow spread.

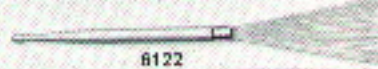

**6122 STICK BRUSHES.** Ideal for "quick change" from either stick or brush work. Telescoping brushes.

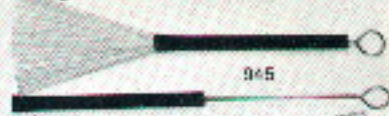

**945 WIRE BRUSHES.** Wide spread. Rubber covered with loop end.



**946 WIRE BRUSHES.** Same as 945 with rubber ball end.

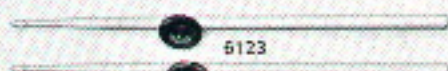

**6123 TAMBOURINE STICKS.** Unique solution to Latin American dance work. Jingles mounted on sticks.

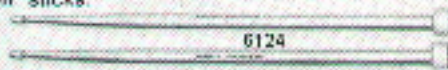

**6124 COMBINATION STICKS.** Deluxe hickory drum sticks with felt handle ends. Excellent for specialty work.

#### ROGERS SUPER TIMPANI STICKS

New, flexible head design to give that genuine, "bottom of the kettle" sound.

**3825** Set of 4 pair, light to heavy described below

**3824** Light

**3823** Medium light

**3822** Medium heavy

**3821** Heavy

#### ROGERS DEMOUNTABLE HEAD TIMPANI STICKS

Genuine hickory, tapered handles, accurately balanced. Special locking device permits replacement of heads simply and easily.

**3810** Solid felt head, 1 3/4" diameter, 14 3/4" overall

**3812** Cartwheel, covered with soft piano felt covering, 1 3/4" diameter, 14 3/4" overall

**3814** Piano felt, fully covered head, hand sewn, 2" diameter, 14 3/4" overall

#### ROGERS TAPERED HANDLE TIMPANI STICKS

**4841** Solid felt heads. Suitable for heavily articulated timpani work — 13" overall, 1 3/4" head

**4843** Piano felt over solid felt core. Ideal for general purpose playing, with moderately articulated response. 13 3/4" overall, 2" head

**4845** Lamb's wool covered head. Artist model, designed for smooth, softly articulated playing. 13 3/4" overall, 2 1/4" head



11A

NYLON TIP

## 1027 REMO 'VERSATILIC' PRACTICE SET

Professionally designed to simulate drum set conditions without the percussive sound volume of an actual drum set. Ideal for home and practice room. Now everyone, professionals and beginners alike, can perfect style, technique and approach before applying rhythmic patterns to a drum set. Center control knob provides immediate and complete adjustment of extension arms. Each pad has height and tilting adjustment.



*Complete as illustrated.*

**1033** 10" Tunable Pad



**1030** 8" Tunable Pad



**1028** 6" Tunable Pad



### REMO TUNABLE PRACTICE PADS

Tensions like a drum. Duplicates stick feel and rebound. Designed for stick or brush work. Rubber base keeps pad from creeping. Weather King Mylar heads.

## 4891 FIPS 'COM-PAC' SILENT PRACTICE SET

True drum feel without the sound. Here's an amazing light weight and complete practice set which is noted for its compactness and sturdy construction. Can be easily adjusted to duplicate the arrangement of any drum set. Unique cymbal muffler is made of elasticized material. Mylar drum heads.



*Complete as illustrated plus cymbal muffler.*



### PRO PRACTICE PAD SET

A flat top practice pad of the type recommended by many prominent teachers. With non-skid flat base for use without stand on flat surface. Heavy duty stand is fully adjustable with spread rubber-tipped legs.

1640 Pad and Stand complete

7397 Pad only

4021 Stand only



### 7387 MASONITE PAD PLATFORM

13 $\frac{3}{4}$ " O.D. tempered Masonite with  $\frac{1}{4}$ " x 20" machine screw for attachment to all Weather King Practice Pads for use on top of snare drum or any snare drum stand.



## AVEDIS ZILDJIAN CYMBALS

### DANCE CYMBALS

Choice of sizes and weights, judged best for all-around work.

- 6003 12" Thin
- 6004 12" Medium
- 6005 13" Thin
- 6006 13" Medium
- 6009 14" Thin
- 6010 14" Medium
- 6013 15" Thin
- 6014 15" Medium
- 6019 16" Thin
- 6020 16" Medium
- 6025 17" Thin
- 6026 17" Medium
- 6029 18" Thin
- 6030 18" Medium
- 6036 19" Thin
- 6037 19" Medium
- 6040 20" Thin
- 6041 20" Medium
- 6047 22" Thin
- 6048 22" Medium

**NOTE:** Cymbals or Gongs May NOT Be Returned. Sizes NOT listed, supplied on special, definite, non-returnable basis. Allow time for delivery.

### HI-HAT CYMBALS

Supplied in pairs only.

- 6007 13" Thin
- 6008 13" Medium
- 6011 14" Thin
- 6012 14" Medium
- 6015 15" Thin
- 6016 15" Medium
- 6021 16" Thin
- 6022 16" Medium

### SPLASH CYMBALS

For fast crash (also called choke).

- 6001 8" Paper Thin
- 6002 10" Paper Thin

### Be-Bop "RIDE"

A gradually tapered cymbal that answers the growing demand of the many modern drummers playing the "New Jazz".

- 6031 18" Medium
- 6042 20" Medium
- 6049 22" Medium

### SIZZLE CYMBALS

Regular cymbals in which rivets are installed to give a sizzling or buzzing type of cymbal sound.

- 6032 18" Thin
- 6033 18" Medium
- 6038 19" Thin
- 6039 19" Medium
- 6043 20" Thin
- 6044 20" Medium
- 6050 22" Thin
- 6051 22" Medium

### 1584 ZIL-BEL CYMBAL SNAPS

Holds cymbal securely on stand or holder. Will not come loose. Eliminates need of wing nuts. Spring-controlled snap top lifts for easy removal or placement of cymbal. Chrome plated.



### 6085 CHING RING

For hi-hat and ride cymbals. 8 pair of jingles bounce to produce a variety of unusual sounds, rhythms and beats. Especially popular in Rock 'N' Twist, Latin and Modern jazz musical arrangements.



### MARCHING BAND CYMBALS

A size and weight for every marching band need. For the optimum in musical sound, order in pairs to assure cymbals are correctly matched and tuned. Order by pair.

- 6017 15" Medium
- 6018 15" Medium Heavy
- 6023 16" Medium
- 6024 16" Medium Heavy

Leather or lamb's wool pads and straps are recommended. Order separately from pad and strap listing on opposite page.

### CONCERT BAND CYMBALS

Greater variety of tonal color, used primarily in large concert bands. Order by pair.

- 6027 17" Medium
- 6028 17" Medium Heavy
- 6034 18" Medium
- 6035 18" Medium Heavy
- 6045 20" Medium
- 6046 20" Medium Heavy

### 6080 CROTALES (ANTIQUÉ CYMBALS)

These special cymbals are finely tuned in a 2 octave chromatic range from an octave below middle C to an octave above.

Specify pitch.



### 6079 FINGER CYMBALS

Have piercing ring audible in even the largest orchestras. These small untuned cymbals are matched for a pleasing blend of tone. Specify thick (highest pitch) or thin.





## ROGERS CYMBALS

Acclaimed by many prominent drummers and bandmen as the very finest Turkish type, imported cymbals on the market. They have that brilliant, penetrating and resonant tonal quality especially suitable for modern orchestra use. Cymbals CAN NOT be guaranteed perfect in size or weight.

### Rogers "THIN" CYMBALS

Sharp, high pitched tone, instant response, ideal for fast crash and splash effects.

- 6058 10" Diameter
- 6059 12" Diameter
- 6062 13" Diameter
- 6065 14" Diameter
- 6068 15" Diameter
- 6071 16" Diameter
- 6074 18" Diameter
- 6076 20" Diameter

### Rogers "MEDIUM" CYMBALS

Good for Hi-Hat crash effects and tip work. Big, piercing, responsive tone. Ideal for "Bounce" or "Ride".

- 6080 12" Diameter
- 6063 13" Diameter
- 6066 14" Diameter
- 6069 15" Diameter
- 6072 16" Diameter
- 6075 18" Diameter
- 6077 20" Diameter
- 6078 22" Diameter

### Rogers "MEDIUM HEAVY" CYMBALS

Ideal for Band, Drum Corps, or Symphony. Matched heavy cymbals, selected for rich, brilliant tone and sustained vibration. Cymbals listed and priced singly, but should be ordered by "pairs".

- 6081 12" Diameter
- 6064 13" Diameter
- 6087 14" Diameter
- 6070 15" Diameter
- 6073 16" Diameter

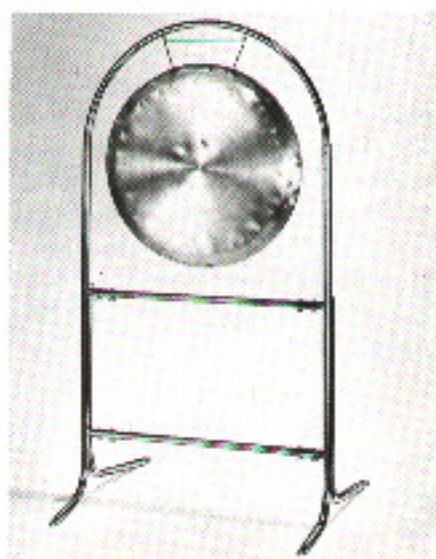

### ZILDJIAN GONGS

Avedis Zildjian Gongs are noted for their magnificent resonance and long-lasting tone. They are a necessity for true gong tone in Near Eastern influenced musical selections. Made in thin (crashy), medium and heavy (deep and mellow) weights. Specify size and weight when ordering.

- 6052 18" diameter
- 6053 20" diameter
- 6054 22" diameter
- 6055 24" diameter
- 6056 26" diameter
- 6057 28" diameter

6082 Rogers Gong Stand (Chrome plated)

### 6083 GONG Mallet

The correct gong mallet is as important as the correct gong. Extra heavyweight head (1 lb. 8 oz.) covered with lamb's wool is designed to bring out the best in any gong. Chrome plated handle. Leather wrist thong.

6084 T-Boom Beater



### 731 CYMBAL SIZZLER

Converts your standard cymbal to sizzle without installing rivets.



### 4319 ROGERS CYMBAL POLISH

Especially formulated for cymbals. Preserves, cleans and improves cymbal.



### 4381 ROGERS LEATHER STRAPS

Cymbal strap to match 4380. Individual cellophane wrapping.

### 4380 ROGERS LEATHER PADS

Top-grain double leather cymbal pad with heavy felt inner lining. Permits full cymbal vibration and protects knuckles. Cellophane wrapping.



### 4383 ROGERS LAMB'S WOOL STRAPS

Cymbal strap, lamb's wool on rawhide. Cellophane wrapping.

### 4382 ROGERS LAMB'S WOOL PADS

Professional quality pad, heavy lamb's wool covered top-grain leather, with felt insert. Affords the maximum in cymbal vibration and knuckle protection. Individual cellophane wrapping.



### PAD & STRAP SETS

- 4379 2 leather pads  
2 leather straps
- 4384 2 lamb's wool pads  
2 lamb's wool straps
- 4385 2 lamb's wool pads  
2 leather straps



## ROGERS MYLAR DRUM HEADS

Not affected by weather. Superior sound qualities. Excellent stick and brush response. Mounted on aluminum frame. Even thickness. Three thicknesses to select from.

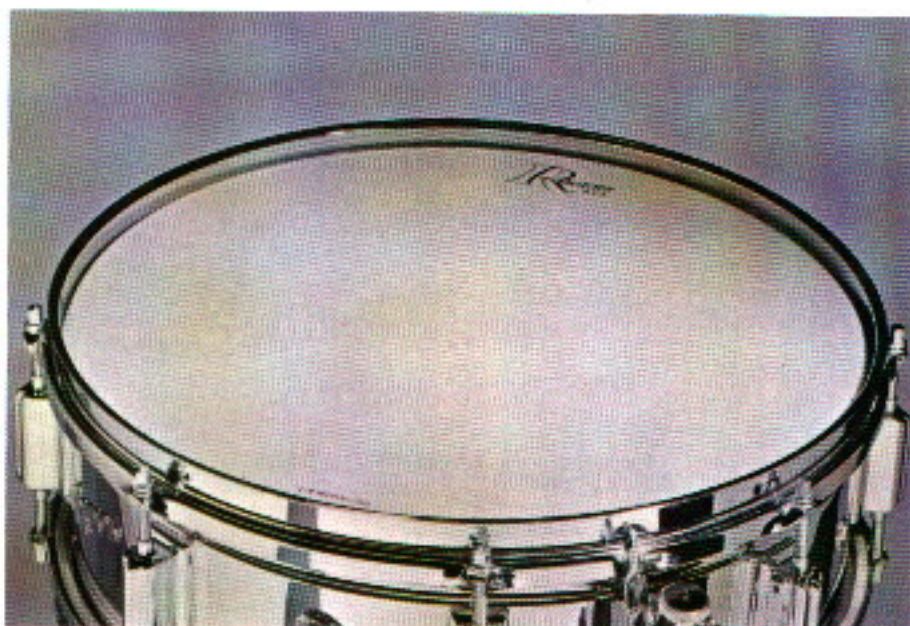

**AMBASSADOR** is a medium weight drum head. It was created to meet the requirements of the professional for all around orchestra work. Its tonal qualities and performance make it the ideal general purpose drum head.

### AMBASSADOR "SNARE"

6203	Size 13"
6207	Size 14"
6214	Size 15"
6221	Size 16"

### AMBASSADOR "BATTER"

6204	Size 13"
6209	Size 14"
6216	Size 15"
6223	Size 16"

### AMBASSADOR "TOM-TOM"

6202	Size 12"
6206	Size 13"
6213	Size 14"
6220	Size 15"
6226	Size 16"
6229	Size 18"

### AMBASSADOR "BASS DRUM"

6253	Size 18"
6254	Size 20"
6255	Size 22"
6256	Size 24"
6257	Size 26"
6258	Size 28"
6259	Size 30"
6260	Size 32"
6261	Size 34"
6262	Size 36"
6263	Size 40"

**DIPLOMAT** is a thin, light weight professional drum head designed for the concert drummer who wants extra sensitivity and quick response.

### DIPLOMAT "BATTER"

6211	Size 14"
6218	Size 15"

### DIPLOMAT "TOM-TOM"

6201	Size 12"
6205	Size 13"
6212	Size 14"
6219	Size 15"
6225	Size 16"
6228	Size 18"

**EMPEROR** is a heavy duty drum head designed to absorb considerable impact over long periods of time with little or no sacrifice in tonal excellence. Highly recommended for drum and bugle corps and all marching bands.

### EMPEROR "SNARE"

6208	Size 14"
6215	Size 15"

### EMPEROR "BATTER"

6210	Size 14"
6217	Size 15"
6224	Size 16"
6227	Size 17"

## ROGERS PRO-LINE DRUM HEADS

Available in Orchestra and Field weights. Pro-Line is a new line of top quality, all plastic heads with new style, tough plastic flesh hoops.

### BATTER SIDE FOR ORCHESTRA DRUM

6233	Size 14"
6239	Size 15"
6243	Size 16"

### SNARE SIDE FOR ORCHESTRA DRUM

6232	Size 14"
6237	Size 15"

### BATTER SIDE FOR FIELD DRUM

6235	Size 14"
6240	Size 15"
6244	Size 16"

### SNARE SIDE FOR FIELD DRUM

6234	Size 14"
6238	Size 15"

## ROGERS MYLAR TIMPANI HEADS

6271	23"
6272	25"
6273	26"
6274	28"
6275	29"
6276	30"
6277	32"



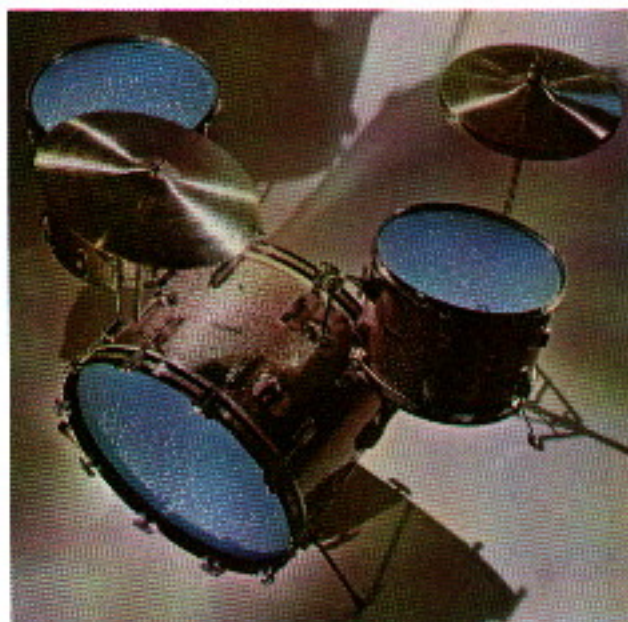

## NEW ROGERS 'COLORFLAKE' DRUM HEADS

For colorful drumming. New style plastic heads add a distinctive sound—and sparkle—to any drum set or marching line. Heads are not affected by weather. Aluminum mounting. Available in five sparkle colors: Red, Silver, Blue, Gold and Green. Batter side only. Specify color. Especially made for Rogers by Remo, Inc.

## ROGERS CALFSKIN HEADS

### DRUM HEADS

#### SNARE —

Transparent — Unmounted

- 6278 18" for 14" Shell  
6279 19" for 15" Shell

#### SNARE — Mounted

- 6285 Mounted for 14"  
6286 Mounted for 15"

#### BATTER —

Whitecalf — Unmounted

- 6280 16" for 12" Shell  
6281 17" for 13" Shell  
6282 18" for 14" Shell  
6283 19" for 15" Shell  
6284 20" for 16" Shell

#### BATTER —

Whitecalf — Mounted

- 6287 Mounted for 12"  
6288 Mounted for 13"  
6289 Mounted for 14"  
6290 Mounted for 15"  
6291 Mounted for 16"

### BONGO HEADS

Mounted to fit Rogers Bongos.

- 6292 Size 6"  
6293 Size 8"

### TIMBALE HEADS

Mounted to fit Rogers Timbales.

- 6294 Size 13"  
6295 Size 14"

### BANJO HEADS

#### DAISY BRAND —

Unmounted

- 6303 14" for 11" Banjo  
6304 15" for 12" Banjo

#### UNION BRAND —

Unmounted

- 6305 14" for 11" Banjo  
6306 15" for 12" Banjo

#### THREE STAR BRAND —

Unmounted

- 6307 14" for 11" Banjo  
6308 15" for 12" Banjo

#### DAISY BRAND — Mounted

- 6313 For 11" Gibson  
6314 For 11" Vega  
6315 For 11" Kay  
6316 For 11" Bacon  
6317 For 11" Fender

#### UNION BRAND — Mounted

- 6318 For 11" Gibson  
6319 For 11" Vega  
6320 For 11" Bacon  
6321 For 11" Kay  
6322 For 11" Fender

#### THREE STAR BRAND —

Mounted

- 6323 For 11" Gibson  
6324 For 11" Vega  
6325 For 11" Bacon  
6326 For 11" Kay  
6327 For 11" Fender

### TOM-TOM

medium weight

- 6170 12" Head  
6172 13" Head  
6173 14" Head  
6174 16" Head

### MARCHING

heavy weight

- 6186 14" Head  
6187 15" Head  
6188 16" Head

### BASS

- 6175 18" Head  
6176 20" Head  
6177 22" Head  
6178 24" Head  
6179 26" Head  
6180 28" Head  
6181 30" Head  
6182 32" Head  
6183 34" Head  
6184 36" Head  
6185 40" Head

## DEAGAN 'DIANA DELUXE' MARIMBA

A deluxe Marimba in the distinguished line of "Diana" Marimbas from Deagan — at moderate cost. An outstanding 4-octave instrument for the solo artist. It is also an excellent choice for the concert band or orchestra.

**SUPERB TONE** — Genuine Honduras rosewood bars ( $2\frac{1}{2}$ " to  $1\frac{1}{2}$ " wide by  $\frac{1}{16}$ " thick) are carefully selected for quality and tuned with exacting skill. Four octaves C-1 to C-49, chromatic.

**BEAUTY OF STYLE AND FINISH** — Slim, enclosed ends and rails are finished in luxurious modern walnut grain with bars dark-stained to harmonize. Resonators and trim are gold-finished for rich contrast. Plastic laminate woodgrain finish on ends and rails.

**DIMENSIONS AND WEIGHT** — Measures  $76\frac{1}{2}$ " long,  $15\frac{1}{2}$ " wide and 34" high (plain scale bars.) Weighs 150 pounds. Disassembles quickly and easily for packing into four cases.

**OTHER FEATURES** — Hinged rails mount in rubber and lock into ends and have rail cross-braces for rigidity. Resonators and cross-bar split for packing. Brakes on two casters. Temperature-humidity adjustments for resonators. Two pairs of Yarn Mallets are included.

**652 "DIANA DELUXE" MARIMBA**  
4 Octaves C to C.

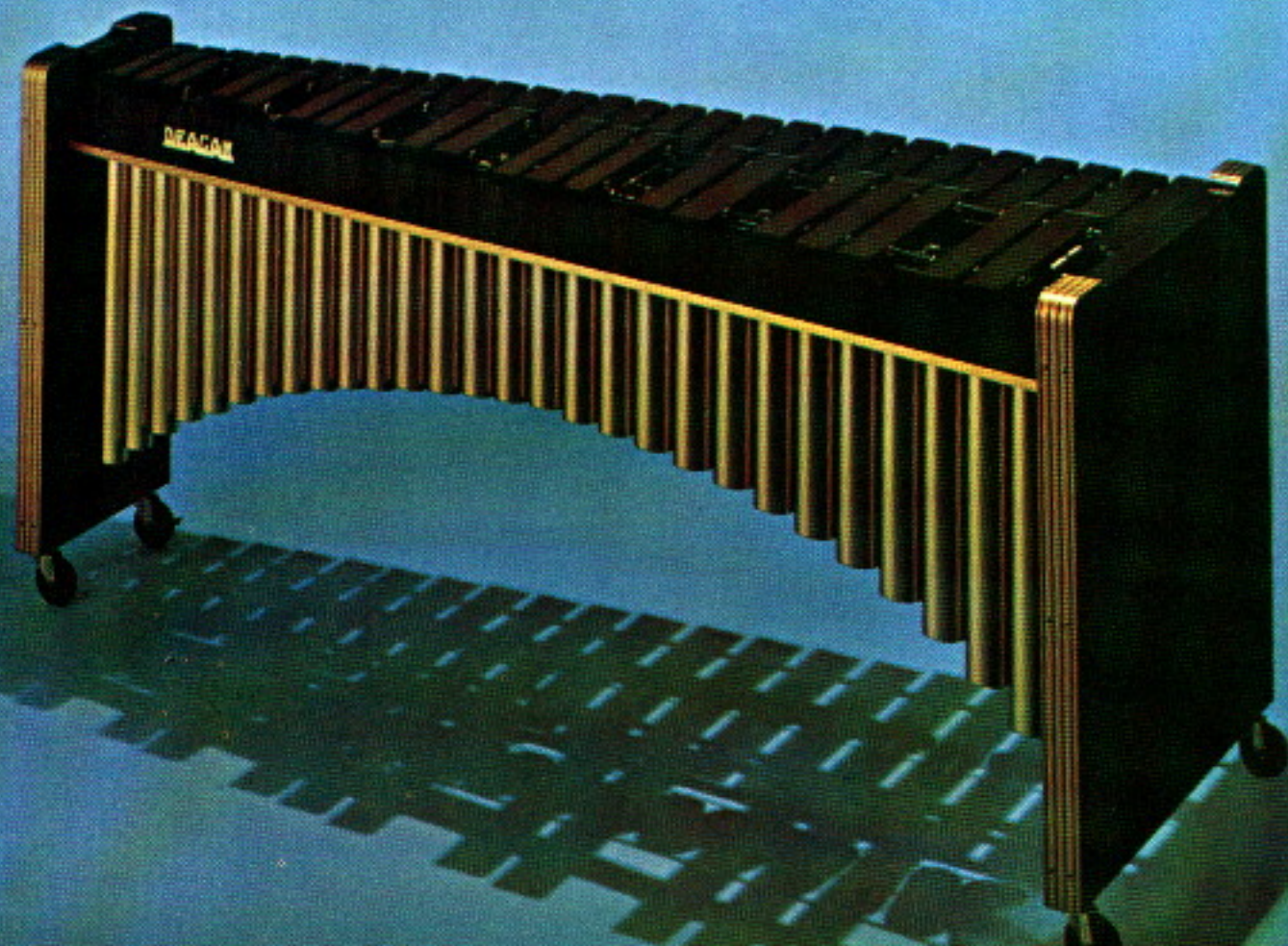

652

## DEAGAN AURORA II VIBRAHARP

The ultimate in quality. The wide aluminum bars of the Model 1100 (2" to 1½" by 1" thick) are satin polished and finished in gleaming anodized gold. Three octaves, F-6 to F-42, chromatic. Rails and ends are finished in Satin Ebony colored high-impact plastic laminate. The result is a stunning contrast with the gold bars, gold-anodized resonators, trim and other aluminum parts.

Newly designed mounting posts on the center rails insure quick, positive dampening of the bars — an innovation on instruments with detachable bars. Weight is a new low 135 pounds! Dimensions are: 54½" long, 16½" to 30" wide, 34" high. Brakes on two casters, hinged rails, rubber mounting for resonators and rails, and Deagan's patented Golden Lyre ratchet-swivel damper pedal are standard. Three pairs of Terry Gibbs mallets (soft, medium and hard) are included.

### INCLUDES VIBRATROL

Continuous vibrato regulation from zero to 12 pulsations per second. Silent mercury switch with indicator light. Quiet high-torque motor. Unit attaches and detaches in seconds.

**1100** Deagan Aurora II Vibraharp with VibraTrol



## DEAGAN 'The COMMANDER' VIBRAHARP WITH VARI-VIBRATO

Large-Bar Professional Portable.

The Commander offers the studio percussionist, the jazz vibist, the club artist or individual musician the ultimate in Vibraharp sound along with portability, variable vibrato — and economy!

Has Deagan's largest bars — like the Aurora II — 2" to 1½" wide by ½" thick. In satin-finished natural aluminum. Three octaves F-6 to F-42, chromatic. Bars are mounted with improved posts as on the Model 1100 — are easily removed for packing. Damper bar is no-bend extruded type.

The new slim-line wood frame is black, highlighted by a feature band of satin-brushed aluminum that blends with the satin aluminum finish on the resonators and bars. Legs are finished in black wrinkle.

Weighs only 96 pounds! Resonators lift out, pedal slips off, and hinged legs fold up and lock for easy handling and transport. Dimensions are: 52¾" long, 16½" to 40¼" wide, 34" high. Quiet Vari-Vibrato motor unit gives a vibrato range of 4 to 8 pulsations per second. On-Off and vibrato range control knob is conveniently located for fingertip operation. Has treadle-type damper pedal — brakes on two casters — resonators mounted in rubber. Three pairs of Terry Gibbs Mallets (soft, medium and hard) are included.

The Commander is the new one from Deagan for big sound plus handling convenience!

**592** DEAGAN COMMANDER Vibraharp with Vari-Vibrato.



## DEAGAN 'The TRAVELLER' VIBRAHARP

With Vari-Vibrato this is a professional quality portable. Similar in appearance to model 592 except bars are uniform; 1½" wide by 1½" thick. Weight 89 lbs. Dimensions are 50½" long, 16¾" to 30" wide and 33¾" high. Narrow aluminum decorative strip highlights the frame. Three pairs of cord mallets: soft, medium and hard. 3 octaves, F to F.

**582** Deagan Traveller Vibraharp, not shown.

## DEAGAN 'The PERFORMER' VIBRAHARP

Here's a semi-pro model with 3 vibrato speeds. Frame construction similar to the model 592, less the aluminum decorative strip. Bar sizes: 1¾" to 1¾" wide by 1½" thick. Weight is only 75 lbs. Dimensions 45¼" long, 16¾" to 30" wide and 33¾" high. Two pairs of cord mallets, medium and hard. 3 octaves, F to F.

**512** Deagan Performer Vibraharp, not shown.

### 1540 DEAGAN BELL LYRA

The 1540 Bell Lyra represents a significant improvement in the design of marching band bells — it is slimmer, trimmer and better balanced. Sharps overlap plain scale bars and make it easier to play.

Heavily chrome-plated frame is formed  $\frac{3}{8}$ " steel tubing construction for extra sturdiness and durability. Weighs 15 pounds. Measures 17 $\frac{1}{2}$ " wide, 28" high. Aluminum alloy bars are 1 $\frac{1}{8}$ " wide by  $\frac{3}{8}$ " thick. Range is two octaves, A to A, chromatic, in C. Pitch A-440.

Bag, Mallets, Strap and Plumes are included.

**1741 BELL LYRA** — Not shown. 2 octaves, A to A chromatic. Weight, 10 $\frac{1}{2}$  pounds. Bag, mallet, strap and plumes included.

**1742 BELL LYRA** — Not shown. 2 octaves, A to A chromatic. Weight, 12 pounds. Bag, mallet, strap and plumes included.

### 1558 DEAGAN ORCHESTRA BELLS

Deagan Orchestra Bells are renowned for their brilliant, musically distinctive bell tones.

2 $\frac{1}{2}$  octaves, G-32 to C-61, chromatic — finest quality hard tempered steel bars, satin polished and chrome plated. 1 $\frac{1}{8}$ " wide by  $\frac{5}{16}$ " thick, individually secured to a wood frame of single-unit construction to prevent detachment and loss. The keratol-covered case is designed for easy removal of the cover, or the bells may easily be lifted out of the case. Case dimensions are 30" long, 18" wide and 3 $\frac{1}{2}$ " deep. Weighs 30 pounds. Music rack and rubber mallets are included.

**1550 DEAGAN BAND BELLS** — Not shown. 2 $\frac{1}{2}$  octaves, G to C. Nickel plated bars 1 $\frac{1}{8}$ " x  $\frac{5}{16}$ ". Weight, 14 pounds. Case and mallets included.

### 9155 DEAGAN ORCHESTRA CHIMES

Not shown.

1 $\frac{1}{4}$ " Diameter — 1 $\frac{1}{2}$  Octaves, C to F Chromatic.

Finish is Lustr-Gold on chimes and uprights with satin gold bronze on base and suspension rack.

Pedal operated damper control same as model 9180.

Dimensions are: 66 $\frac{1}{2}$ " high, 33" wide and 24 $\frac{1}{2}$ " deep at base. Weight is 125 pounds. Brakes provided on two casters. Easily disassembled for packing. One rawhide chime mallet is included with instrument.

### 9180 DEAGAN 'The SYMPHONIC' ORCHESTRA CHIMES

1 $\frac{1}{2}$ " Diameter — 1 $\frac{1}{2}$  Octaves, C to F Chromatic.

Made from select alloy brass especially drawn to rigid chime tubing specifications. Both the nature of the alloy and uniform drawing of the tubing are of critical importance for highest quality.

Deagan Orchestra Chimes give better performance because the individual 1 $\frac{1}{2}$ " diameter chimes are carefully proportioned for control of the tone-producing characteristics of their tubular mass. The extra-heavy wall thickness provides optimum tonal balance and sonority.

Improved Deagan striking heads and flawless tuning insure that each chime will respond to the lightest stroke of the rawhide mallet.

Available in a choice of two finishes — durable heavy chrome on chimes and uprights with aluminum bronze on base and suspension rack, or popular Lustr-Gold on chimes and uprights with satin gold bronze on base and suspension rack.

Pedal operated damper control provides quick, positive damper action. Finger-tip lock holds damper open; lock releases instantly when pedal is depressed.

Dimensions are: 71" high, 33" wide and 24 $\frac{1}{2}$ " deep at base. Weight is 167 pounds. Brakes provided on two casters. Easily disassembled for packing. One rawhide chime mallet is included with instrument.

**9180** (Chrome) ORCHESTRA CHIMES

**9181** (Lustr-Gold) ORCHESTRA CHIMES



1540

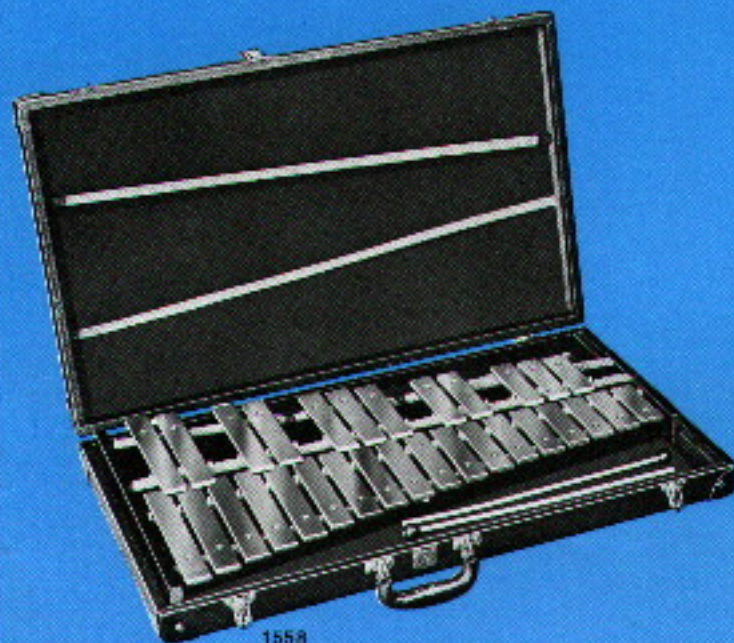

1558

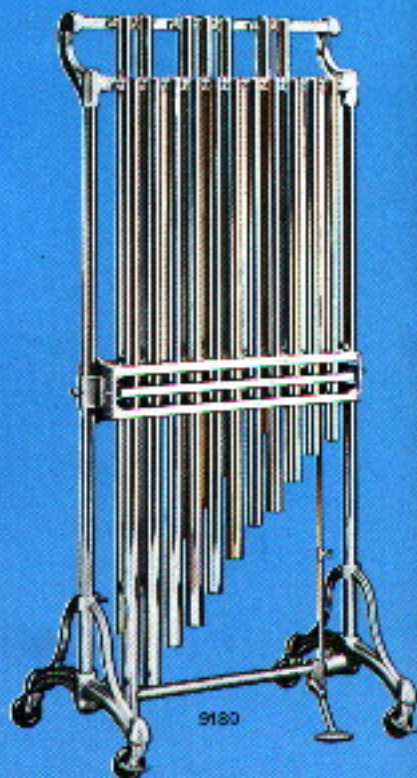

9180

## 932 DEAGAN XYLOPHONE

Designed for maximum handling ease and portability. Bars are mounted on a single-unit frame with folding legs. It weighs only 60 pounds. Range: 3½ octaves, F-18 to C-61, chromatic. The 1½" wide by 1½" thick genuine Honduras rosewood bars are easily removed for packing. Resonators lift out, hinged legs fold up and lock for easy transport. Measures 53½" long, 15" to 30" wide, and 34" high (plain scale bars.) Frame is black ripple, legs and braces are black wrinkle finish. Brakes on two casters. Two pairs of rubber mallets are included.



## 860 DEAGAN SPECIAL-3 XYLOPHONE

Full three-octave range (C-25 to C-61, chromatic). The 1½" wide by ¾" thick cord-suspended bars are made of genuine Honduras rosewood. The bar-mounting frame is affixed to the lower section of the case which has a detachable lid.

The complete instrument, including two pairs of hard rubber mallets, weighs only 28 pounds. The case measures 37½" long, 4½" deep and 25¼ to 35¼" wide.



## BELL MALLETS (XYLOPHONE)

**BRASS HEAD** — Rattan handle  
2000 very hard, ¾" head

**PLASTIC HEAD** — Plastic handle  
2039 very hard, 1" head  
2040 very hard, 1½" head

**PLASTIC HEAD — ROGERS MODEL**  
Wire handle, ribbed rubber grip.  
4890 very hard, 1½" head

**RUBBER HEAD** — Rattan handle  
2001 medium soft, 1" head (Deagan 2002½)  
2002 soft, 1" head  
2003 medium hard, 1" head  
2004 hard, 1" head

## MARIMBA MALLETS

Rubber Head (see Bell Mallet listing)

**YARN WOUND** — Rattan handle  
2023 Extra Soft, 1½" head (Deagan 2020Y) BLUE STITCHING  
2022 Soft, 1½" head (Deagan 2018Y) GREEN STITCHING  
2021 Soft, 1½" head (Deagan 2016Y) BLUE STITCHING  
2017 Med. Soft, 1½" head (Deagan 2015½Y) GREEN STITCHING  
2005 Med. Hard, 1½" head (Deagan 2015Y) ORANGE STITCHING  
2009 Hard, 1½" head (Deagan 2014Y) RED STITCHING

**YARN WOUND** — Fiberglass handle  
**GREAT DANE MODEL**  
4836 Soft, 1½" head. Garnet red.

**LATEX WOUND** — Extra Long slender handles of special Guatemalera. (Jose Bethancourt Models)  
2036 Soft (Andante) 1½" head  
2035 Firm (Scherzo) 1½" head



**GRADUATED CORD** — Rattan handles  
2024 Set of 4, 1½" heads  
1 dot, soft, BLUE STITCHING  
2 dot, Med. Soft, GREEN STITCHING  
3 dot, Med. Hard, ORANGE STITCHING  
4 dot, Hard, RED STITCHING

## VIBE MALLETS

**RUBBER HEAD** (See Bell Mallet listing)  
**YARN HEAD** (See Marimba Mallet listing)



**YARN WOUND** — Fiberglass handle  
**GREAT DANE MODEL**  
4806 Soft, 1½" head, GREY  
4807 Med., 1½" head, BLUE  
4808 Hard, 1½" head, BLACK

**CORD WOUND** — Rattan handle  
2019 Soft, 1½" head (Deagan 2015C) BLUE STITCHING  
2006 Med. Soft, 1½" head (Deagan 2015½C) GREEN STITCHING  
2007 Med. Hard, 1½" head (Deagan 2015C) ORANGE STITCHING  
2011 Hard, 1½" head (Deagan 2014C) RED STITCHING

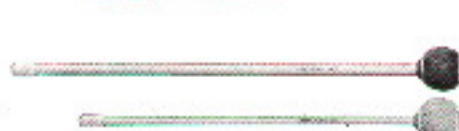

**CORD WOUND** — Rattan handle  
Terry Gibbs Model  
2031 Soft, 1½" — BLUE  
2032 Med., 1½" — GREEN  
2034 Med. Hard, 1½" — ORANGE  
2033 Hard, 1½" — RED



**NYLON — YARN WOUND** Wire handle with cloth-taped rubber hand grip. Megs Model

2041 Med., 1½" head, BLACK  
2043 Med., 1½" head, WINE  
2042 Hard, 1½" head, YELLOW  
2044 Hard, 1½" head, GREEN



**LAMBSKIN COVER** — Maple handle Red Norvo Slap Model, for special effects.  
2038 Soft  
2037 Firm

## ORCHESTRA CHIME MALLETS

**RAWHIDE HEAD** — Wood handle  
2026 Small (for 1½" diameter tubes only)  
2028 Large (for 1½"-1½" diameter tubes)



## DINNER CHIME MALLETS

405 RUBBER HEAD-FELT FLOCKED — wood handle

## 2050 DEAGAN Mallet Caddy

It's a carry bag for mallets and small accessories then — Presto! — it's a mallet holder and organizer on the instrument. Made of durable, light grey leathergrain vinyl. Has full zipper closing, elevator pocket inside for short handle mallets and three snap-closing pockets for oil, pulleys, drive belts, cloths, etc. Lid folds neatly out of way, metal bracket slips over instrument rail and mallets are positioned handily for the performer. Closed, measures 16" x 4½" x 4½".





## ROGERS DRUM CASES



### 418 'PRO' CASE

23" long; 16 1/2" wide; 12 1/2" deep. Has adjustable flap for any popular size snare drum; compartment for accessories. Lift-out tray, holds additional traps and cymbals to 16". Wood frame cover, partial wood frame and metal edged body. Light weight, yet extremely durable.



### 991 'VINALITE' KIT CASE

18 1/2" long; 17 1/2" wide; 7 1/2" deep. Wooden side frames, covered with heavy gauge washable vinyl, in attractive finish. Chromed valance and edges. Has large compartment for stand and accessories.



### 983 DELUXE CASE FOR KITS

19 1/2" long; 16" wide; 7 1/2" deep. Deluxe leather-bound hard shell case, with plush lining. Has compartment for stand, sticks, pad, music, etc. OUR BEST.

### 990 KIT CASE

Same as 983 less corner binding. Fabric lined.



### FIBRE DRUM CASES

Flat bottom. Leather strap (3 straps on Bass and Scotch Drum cases) and leather handle. Made of best grade hard vulcanized fibre. Strongly riveted.

### SNARE DRUM CASES

420 for 5x14  
409 for 6 1/2 x 14  
421 for 7 or 8x15

### TOM-TOM CASES

812 for 8x12  
913 for 9x13  
1414 for 14x14  
1214 Combination for 8x12 and 14x14  
1614 for 16x14  
1616 for 16x16  
1618 for 16x18  
1316 Combination for 9x13 and 16x16

### PARADE DRUM CASES

1014 for 10x14  
1216 for 12x15  
1216 for 12x16

### BASS and SCOTCH DRUM CASES

1420 for 14x20  
1222 for 12x22  
1422 for 14x22  
1424 for 14x24  
2610 for 10x26  
1426 for 14x26  
2810 for 10x28  
1428 for 14x28

Other sizes available on special order.

### ROGERS ALL-PURPOSE BASS DRUM CASE

WITH FLAT TOP AND BOTTOM. Best case ever devised to hold drums without removing spurs. Heavy duty vulcanized fibre.

1814 for 18" Drum  
1421 for 20" Drum  
1423 for 22" Drum



### 514 ROGERS 'FIBER-KRAFT' CASE

Case for snare drum, accessories and cymbals. Holds any 14" drum while lift-out tray accommodates traps and cymbals up to 17" size. Two additional accessory compartments for traps.



### 416 FIT-ALL DRUM CASE

22 1/2" long; 10 1/2" wide; 22 1/2" deep. Holds drum and traps, and cymbals up to 22". Drum compartment holds any size snare drum. Separate accessory compartments. Tray is extra large. Ideal for storing extra traps. Sturdy vulcanized fibre, with reinforced metal corners. Heavy duty hardware, plastic handle and two heavy leather straps.

### 417 FIT-ALL CASE WITH WHEELS

Same as 416, with wheels attached.

### 415 CARRY-ALL DRUM CASE

Similar to 416, smaller in size. 22" long; 10" wide; 18 1/2" deep. Holds up to 15" cymbal.



### 419 SNARE DRUM CASE

19 1/2" long; 16 1/2" wide; 7 1/2" deep. Budget priced. Holds standard 14" snare drum. Has compartment for basic accessories.



### 413 BONGO CASE

Holds standard bongos. Also serves as utility case for beaters, traps and music. HEAVY DUTY Vulcanized fibre



### 414 CYMBAL CARRYING CASE

For cymbals up to 16" diameter. Ideal for band, concert or dance work. Heavy duty. Vulcanized fibre.

## METHOD BOOKS FOR SNARE DRUM



7100

**7100—Rogers Elementary Drum Method**  
by Roy Burns.  
For the beginning school drummer. Emphasis on hand position, reading, counting and beginning technique.



7102

**7101—Intermediate Drum Method**  
by Roy Burns and Saul Feldstein.  
Excellent junior high percussion method. Special section with pictures and explanations of how to play traps, exercises to develop skills.

**7102—Modern Interpretations of Snare Drum Rudiments**  
by Buddy Rich.  
Comprehensive introduction to the practical use of traditional patterns.



7103

**7103—Rogers Drum Primer**  
by Louis Bellson.

**7104—Drum Set Primer**  
by Louis Bellson.  
Essentials of modern musical drum performance.



7105

**7105—Drum Techniques**  
by Cory Cole.  
Provides a strong technical foundation for creativity.



7106

**7106—Stick Control**  
by George L. Stone.  
The most complete collection of sticking exercises directed at building superior hands for the beginning or advanced student.

**7107—Accents and Rebounds**  
by George L. Stone.  
Beautifully organized to develop equal accents with either hand within any pattern. Intermediate to advanced.



7108

**7108—Variations of Drumming**  
by Ralph Pace.  
A carefully organized book for snare drum or set with excellent supplementary reading material and stick control exercises.

**7110—Drum Method**  
by Charley Wilcoxon.  
A unique and motivating approach to beginning drumming.



7110

**7111—The Junior Drummer**  
by Charley Wilcoxon.  
Fascinating studies with built-in student interest.

**7112—The All-American Drummer**  
by Charley Wilcoxon.  
150 intermediate modern studies with unique stickings in a traditional context.

## KEYBOARD MALLET PERCUSSION COLLECTIONS



7160

**Bach, Beethoven, Brahms—Duets or Trios**  
by Harold Farberman.

**7160—Vol. I, Elementary.**

**7161—Vol. II, Intermediates.**

**7161—Vol. III, Advanced.**



7161

**7161—15 Bach Inventions**  
by Morris Lang.

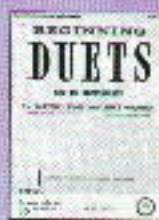

7162

**7162—Book 1, Beginning Duets**  
by W. Lewis and M. Widmer.

**7163—Book 2, Beginning Duets**  
by W. Lewis and M. Widmer.

Very Elementary.



7164

**7164—Jazz for Juniors**  
by Carl Pool.  
Elementary introduction to jazz style in duet form for mallet instruments.

**7165—Jazz for Seniors**  
by Carl Pool.  
Intermediate jazz duets for mallet instruments.



7166

**7166—12 Themes**  
by Barry Miles.  
Intermediate and advanced originals with wittic improvisations in contemporary jazz style.



7144

**7144—Percussion Keyboard Technic**  
by McMillan.

Beginning keyboard mallet method with many short familiar melodies well placed in terms of key relationship and difficulty.



7145

**7145—Modern School for Xylophone, Marimba and Vibes**  
by Morris Goldenberg.  
Popular keyboard mallet method with orchestral excerpts and repertory in final sections. Elementary to advanced.



7146

**7146—Xylophone and Marimba Method—Vol. I**  
by Florence Schaefer.  
Method book for intermediate mallet student with exercises to develop technique.



7147

**7147—Vol. I Modern Mallet Method**  
by Phil Kraus.

**7148—Vol. II Modern Mallet Method**  
by Phil Kraus.

**7149—Vol. III Modern Mallet Method**  
by Phil Kraus.

Complete comprehensive series with total music background. Takes student from elementary music study to professional performance level.



7160

**7160—Mallet Technique for Bass and Treble Clef**  
by Saul Feldstein.  
A unique book covering the neglected bass clef for elementary and intermediate students.



7161

**7161—Marching Bells**  
by Feldstein and Kraus.  
A special book including valuable techniques and ideas. Elementary to intermediate.

## KEYBOARD MALLET PERCUSSION—TECHNICAL STUDIES



7162

**7162—Reading and Technical Studies**  
by Billy Dorn.  
A popular technique builder. Intermediate.

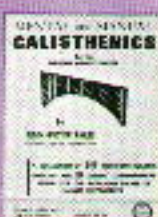

7153

**7153—Callisthenics for the Modern Mallet Player**  
by Elden Bailey.  
A progressive, enlightened approach to contemporary mallet performance in many styles. Advanced.



7154

**7154—Contemporary Scales and Chords**  
by Rudy F. Hermann.  
For the four-mallet player interested in contemporary harmonic structures.



7155

**7155—Double Steps**  
by Al Payson  
Double step scales and arpeggios using various intervals and octave work. Excellent for the intermediate and advanced mallet student.



7156

**7156—Jazz Phrasing for Mallets**  
by Johnny Ray  
Emphasis on melodic turn-around and line phrasing in the jazz idiom.



7157

**7157—Schubert Unaccompanied Song Studies**  
by Musser, Campbell and Feldstein  
Supplementary material to teach romantic style for mallet percussionists.



7158

**7158—Vibes for Beginners**  
by Phil Kraus  
Elementary method specifically for the young vibist, including integrated pedal work.

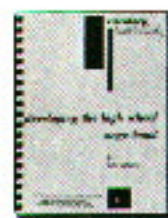

7159

**7159—Vibes for Stage Band**  
by John LaPorta  
Part of "Developing the High School Stage Band" series.

### DRUM OUTFIT STUDY BOOKS



7123

**7123—Vol. I—Elementary—Introduction to The Drum Set**  
by Charles Perry  
Outstanding beginning method for the young drummer at the set.



7124

**7124—Design for Drum Set**  
by Don Lamond  
Emphasis on basic drum technique and its relationship to other instruments of the set. Elementary to intermediate.



7125

**7125—4-Way Coordination**  
by Dahlgren and Fine  
Outstanding new approach to independence of all 4 limbs. Advanced.



7126

**7126—Rhythmic Patterns**  
by Jose Cuatrecasas  
Designed to develop smooth and rapid movement from drum to drum on the set. Advanced.



7127

**7127—Developing Drum Breaks**  
by Igou and Adler  
Sample breaks with opportunity to begin improvised solos and fills. Intermediate to advanced.



7128

**7128—New Time Signatures Jazz Drumming**  
by Ed Shaughnessy  
Well organized approach to odd time signature in contemporary jazz styles. Advanced.

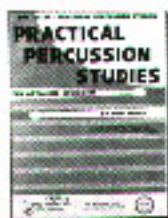

7129

**7129—Practical Percussion Studies**  
by Bob Tilles  
For the study of studio or pit work requiring reading skills and percussion versatility. Intermediate to advanced.



7130

**7130—The New Conceptions**  
by Morris Lang  
Logically organized notational approach to multiple percussion or set reading and performance. Intermediate to advanced.



7131

**7131—Advanced Technique for the Modern Drummer**  
by Jim Chapin (vol. 1)  
Left hand independence studies for the advanced player.



7132

**7132—Manual for the Modern Drummer**  
by Alan Dawson and Don DeMicheal  
Comprehensive collection of jazz oriented concepts. Not a practice book but a reference book for detailed jazz styles. Intermediate to advanced.

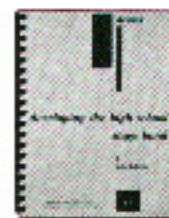

7133

**7133—Developing The High School Stage Band**  
by John LaPorta  
Exercises designed to teach jazz style to the school stage band drummer. Intermediate to advanced.

### SCHOOL SOLO COLLECTIONS, MARCHING CADENCES AND DRUM CORPS BOOKS



7114

**7114—Modern Rudimental "Swing" Solos**  
by Charley Wixson  
Excellent collection of solo material with traditional patterns designed to "swing".



7115

**7115—14 Contest Solos for Snare Drum**  
by John Pratt  
Fine rudimentally oriented solos with interesting across-the-bar patterns.



7116

**7116—The Drummer on Parade**  
by Charley Wixson  
Cadences for the high school drum section.



7117

**7117—128 Rudimental Street Cadences**  
by John Pratt  
Intermediate to difficult cadences for Parade Drums and Bass Drums, or Parade Drums, Tenor Drums, Bass Drums, and Cymbals.



7118

**7118—101 Street Beats**  
by Samuel Floyd  
Slanted toward the junior high band on parade, these cadences are easy to moderately easy with a few advanced.

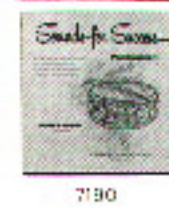

7190

**7190—Sounds for Success Record**  
performed by Marvin Britton  
A listen-play recording. Ideal for home and classroom practice to develop well-rounded musicianship.





7119

**7119—Precision Drumming**  
by Larry McCormick.  
Modern drum corps concepts including detailed explanations and sample scores. Advanced.

**7120—Back Sticking**  
by Larry McCormick.  
Precision stick technique.

**7121—Cadences • Solos**  
by Larry McCormick.  
Corps oriented parade routines.

**7122—Tenor Drum Method**  
by Larry McCormick.  
Designed to emphasize integration of tenor drums in outdoor drum sections.

7122



**7174—Modern School for Snare Drum**  
by Morris Goldenberg.  
Excellent reading book with Artist Percussionist Section.



**7175—Reading by Recognition**  
by Joseph Leavitt.  
A unique reading system with ample practice exercises.



**7176—Contemporary Music**  
by Joseph Leavitt.  
A reference book for the advanced percussionist interested in avant garde percussion in "new music".



**7177—Modern Reading Text**  
by Bellson and Brines.  
Emphasis on reading syncopated rhythms.



**7178—Portraits in Rhythm**  
by Anthony J. Cirone.  
Intermediate to advanced supplementary studies.



7134

**7134—Timpani Method**  
by Frase Lepak.  
Complete timpani method with repertory section. Beginning to advanced.



7135

**7135—Modern Method for Tympani**  
by Saul Goodman.  
Complete timpani method with repertory section. Beginning to advanced.



7136

**7136—Timpani Tuning**  
by Marvin Britton.  
Designed for developing tuning proficiency. Many exercises with graduated difficulty including all intervallic combinations. Intermediate to advanced.



7137

**7137—The Solo Timpanist**  
26 Etudes  
by Vic Firth.  
Excellent 2, 3 and 4 timpani etudes for the advanced timpanist. The purpose of each etude is clearly explained in well organized, meaningful paragraphs. Moderately difficult to advanced.



7138

**7138—Timpani Method**  
by McMillan.



7122

### CYMBAL STUDY BOOKS



7142

**7142—The Art of Playing Cymbals**  
by Sam Denoy.



7143

**7143—Cymbals for Stage and Dance Bands**  
by Roy Burns.



7171

**7171—Finger Control**  
by Roy Burns and Lewis Malin.  
Advanced special technique book.



7172

**7172—Wrist and Finger Stroke Control**  
by Charles Wilcox.  
Intermediate special technique book.

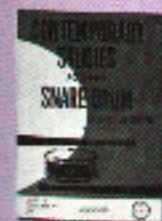

7173

**7173—Contemporary Studies for Snare Drum**  
by Fred Albright.  
Advanced reading book.

### PERCUSSION MANUALS FOR TEACHERS



**7168—A Guide to Teaching Percussion**  
by Harry Buellett.  
A class percussion text and excellent reference book for teachers.



**7169—Percussion Manual for Music Educators**  
by Joel Leach.  
A percussion class method for teachers with exercises for playing each instrument.



**7170—Music Educators Guide to Percussion**  
by Al Payson and Jack McKenzie.  
An informative, ready-indexed reference.

### TIMPANI METHODS AND STUDY BOOKS

### LATIN AMERICAN BOOKS



7139

Definitive Latin American books including dance rhythms and proper use of sound variations on basic Latin instruments. Elementary to advanced.

**7139—Latin American Rhythm Instruments**  
by Humberto Morales.



7140

**7140—Authentic Congo Rhythms**  
by Bob Evans.

**7141—Authentic Bongo Rhythms**  
by Bob Evans.



Roy Burns

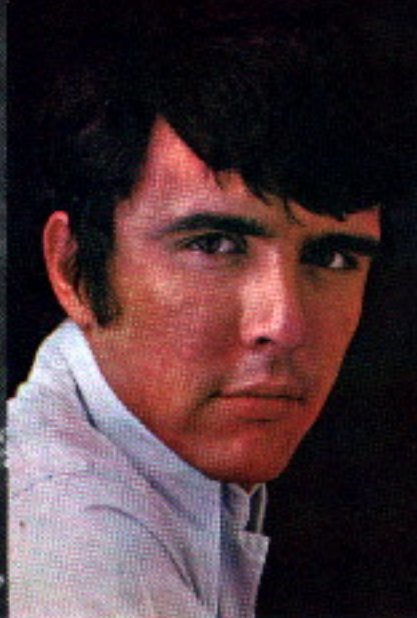

Dave Clark



Cozy Cole



Humberto Morales

INDEX

**A**  
 Accessory Throat . . . . . 38  
 Anchor, Bass Drum . . . . . 47  
 Antique Cymbals (Crystals) . . . . . 52  
 Arm, Cymbal Extension . . . . . 32

**B**  
 Back Rest, Throne . . . . . 30  
 Bags, Cymbal . . . . . 65  
 Band Bells . . . . . 58  
 Bango Heads . . . . . 55  
 Bass Drum Rack . . . . . 28  
 Bass Drums . . . . . 22, 28  
 Beaters and Mallets . . . . . 45, 47, 49, 53, 58  
 Beaters, Mallet . . . . . 36  
 Beater, T-Bass . . . . . 47, 53  
 Bell, Lyra . . . . . 58  
 Bells, Cha-Cha & Mambo . . . . . 42  
 Bells, Skitch . . . . . 44  
 Blacks, Temple . . . . . 40  
 Blacks, Wood . . . . . 43  
 Bongos . . . . . 41  
 Bongo Heads . . . . . 55  
 Books, Instruction . . . . . 41-65  
 Brushes . . . . . 49

**C**  
 Cases, Drums . . . . . 60  
 Cases, Throne . . . . . 39  
 Castanets . . . . . 44  
 Cha-Cha Bell . . . . . 42  
 Chime Mallets . . . . . 59  
 Chimes . . . . . 59  
 Ching Ring . . . . . 52  
 Chopala (Tubax) . . . . . 42  
 Clamps . . . . . 34  
 Claws . . . . . 42  
 Claws, Triangle . . . . . 44  
 Clutch, Hi-Hat . . . . . 34  
 Collar Nose . . . . . 33  
 Collar Plates . . . . . 33  
 Colibrika Heads . . . . . 55  
 Combination Holder . . . . . 45  
 Concert Bass Drums . . . . . 28  
 Concert Tom-Toms . . . . . 40  
 Conga Drum . . . . . 42  
 Cowbell, Drum . . . . . 45  
 Cowbell, Throne . . . . . 56  
 Covers, Timbales . . . . . 41  
 Cowbell Holders . . . . . 43  
 Cowbell and Wood Block Holder . . . . . 43  
 Cowbells . . . . . 42  
 Crystals (Antique Cymbals) . . . . . 52  
 Cymbals . . . . . 62, 63  
 Cymbal Bags . . . . . 45  
 Cymbal Holders . . . . . 32, 47  
 Cymbal Holders, Hand Style . . . . . 53  
 Cymbal Pads and Seta . . . . . 53  
 Cymbal Polish . . . . . 53

Cymbal Sizzler . . . . . 53  
 Cymbal Snaps . . . . . 52  
 Cymbal Stands . . . . . 22, 34, 35

**D**  
 Drum Key . . . . . 31  
 Drum Kits . . . . . 19, 21  
 Drums, Bongo . . . . . 41  
 Drums, Conga . . . . . 43  
 Drums, Outfit . . . . . 4, 13

**F**  
 Film Cases . . . . . 60  
 Field Drums . . . . . 24, 28  
 Finger Cymbals . . . . . 52  
 Finishes . . . . . 66  
 Foot Pedals . . . . . 38, 37

**G**  
 Gankangul, Bell Lyra . . . . . 58  
 Gang Mallets . . . . . 53  
 Gang Stand . . . . . 53  
 Gongs . . . . . 53  
 Gumbo . . . . . 42

**H**  
 Hand Cymbal Holders . . . . . 63  
 Harness . . . . . 47  
 Heads, Banjo . . . . . 55  
 Heads, Drum . . . . . 54, 56  
 Head Rest, Throne . . . . . 38  
 Hi-Hat Clutch . . . . . 34  
 Hi-Hat Pedals . . . . . 34, 55  
 Hi-Hat Mount . . . . . 6  
 Hi-Stepper, Drum Holder . . . . . 47  
 Holders, Cymbal . . . . . 32  
 Holders, Tom-Tom . . . . . 31  
 Holders, Triangle . . . . . 44

**I**  
 Instruction Books . . . . . 61-65  
 Internal Tone Control (Muffler) . . . . . 47

**J**  
 Jingle Socks, Tambourne . . . . . 49

**K**  
 Key, Drum . . . . . 30  
 Kits, Drum . . . . . 19, 20  
 Knobby Units . . . . . 32

**L**  
 Leg Rests . . . . . 47  
 Legs, Tom-Tom . . . . . 33

**M**  
 Mallets . . . . . 47, 53, 58  
 Mallet Caddy . . . . . 58  
 Mallet, Conga . . . . . 53  
 Mallet, T-Bass . . . . . 47, 53  
 Mambo Bell . . . . . 42  
 Maracas . . . . . 43

Marching Drums . . . . . 24, 28  
 Marimbas . . . . . 60  
 Methods, Instruction . . . . . 61-65  
 Mufflers . . . . . 47

**N**  
 Nylon Tip Sticks . . . . . 48

**O**  
 Orchestra Bells . . . . . 59  
 Oudins, Drum . . . . . 4, 13

**P**  
 Pads, Cymbal . . . . . 53  
 Parade Drums . . . . . 24, 28  
 Pedal Beaters . . . . . 38  
 Pedals . . . . . 38, 37  
 Platform, Practice Pad . . . . . 51  
 Polish, Cymbal . . . . . 53  
 Practice Pads and Seta . . . . . 50, 51

**R**  
 Rachel . . . . . 44  
 Rack, Bass Drum . . . . . 28  
 Racks, Bass . . . . . 38  
 Racks, Head . . . . . 38  
 Rests, Leg . . . . . 37

**S**  
 Sand Blocks . . . . . 44  
 Scotch Drums . . . . . 25-27  
 Seats . . . . . 30  
 Shaver, Wind . . . . . 42  
 Shell Mounts . . . . . 31, 33  
 Sings . . . . . 44  
 Sizzlers, Cymbal . . . . . 53  
 Sizzlers . . . . . 44  
 Sleigh Bells . . . . . 44  
 Slings . . . . . 47  
 Snow Drums . . . . . 14-18  
 Snow Sizzlers . . . . . 38  
 Snare . . . . . 38  
 Sock Pedals . . . . . 34, 35  
 Song Whistle . . . . . 44  
 Spurs . . . . . 47  
 Spur Scape . . . . . 47  
 Suspenders . . . . . 20  
 Bass Drum . . . . . 20  
 Cymbal . . . . . 32  
 Gong . . . . . 53  
 Practice Pad . . . . . 51  
 Snow Drum . . . . . 33  
 Tom-Tom Stand . . . . . 40  
 Timbale . . . . . 41  
 Tom-Tom, Dual . . . . . 33  
 Stick Brushes . . . . . 48  
 Stick Trays . . . . . 34  
 Sticks . . . . . 48, 49  
 Bass Drum . . . . . 46  
 Beaters . . . . . 46, 47, 49

Combination . . . . . 49  
 Scotch Drum . . . . . 48  
 Tambourne . . . . . 49  
 Tom . . . . . 46, 47  
 Timbale . . . . . 41  
 Timpani . . . . . 49  
 Stool . . . . . 38, 39  
 Strainers . . . . . 38  
 Straps, Cymbal . . . . . 53

**T**  
 T-Bass Beater . . . . . 47, 53  
 T-Bassera Socks . . . . . 69  
 Tambourne . . . . . 44  
 Temple Blocks . . . . . 40  
 Tenor Drums . . . . . 24-27  
 Thrones . . . . . 38, 39  
 Tines and Extension Arms . . . . . 30, 32  
 Tomtoms . . . . . 41  
 Tom-Toms . . . . . 21  
 Tom-Tom, Concert . . . . . 40  
 Tom-Tom Holders and Parts . . . . . 31, 33  
 Tom-Tom Legs . . . . . 33  
 Tom-Tom Stand . . . . . 33, 40  
 Tone Control . . . . . 47  
 Trap Table . . . . . 40  
 Traps . . . . . 42, 44  
 Traps, Stick . . . . . 34  
 Triangles and Holder . . . . . 44  
 Tubax (Chopala) . . . . . 42

**V**  
 Vinesaps (Vibes) . . . . . 57

**W**  
 Whistles . . . . . 44  
 Wire Brushes . . . . . 49  
 Wood Block Holders . . . . . 43  
 Wood Blocks . . . . . 43  
 Wood Guinea . . . . . 42  
 Wood Shaker . . . . . 42

**X**  
 Xylophone . . . . . 59

When ordering Rogers Drums and accessories, please be specific in providing catalog numbers, sizes and finishes desired. Special orders are on a non-cancelable and non-refundable basis. All drums are supplied with plastic heads unless otherwise specified. Call heads will be supplied at extra cost. Chrome hardware is standard unless otherwise noted. Parts and sub-assemblies not listed appear in the Rogers Parts Catalog. Detailed price list available.

# ROGERS DRUM FINISHES

The flashing highlights of sunlight or spotlight on Rogers lustrous pearl and gleaming chrome add another dimension to the Rogers story . . .

This beauty is more than skin deep.

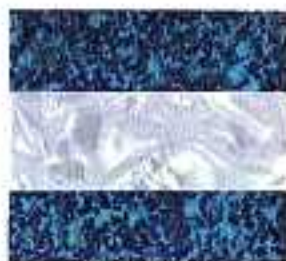

\*COMBINATION



STEEL-GRAY RIPPLE PEARL



WINE-RED RIPPLE PEARL



RED ONYX PEARL



BLUE ONYX PEARL



BLACK ONYX PEARL



MARINE PEARL



BLACK DIAMOND PEARL



JET BLACK PEARL



BLACK STRATA PEARL



PINK STRATA PEARL



BLUE STRATA PEARL



PINK CHAMPAGNE PEARL



SILVER SPARKLE PEARL



GREEN SPARKLE PEARL



BLUE SPARKLE PEARL



RED SPARKLE PEARL



GOLD SPARKLE PEARL

## PERCUSSION PROBLEMS?

When you're not quite satisfied with your percussion sound, get in touch with the Rogers Education and Research Department. *Just write!* Be specific — and we'll reply. Here's one more way in which Rogers does more for percussion and you!

The new *Rogers Sound Analysis Laboratory* is an industry first, leading the way in the search for perfect percussion. Its performance helps us give you better answers to percussion problems.

## WRITE FOR

### Music Education Consultation

Personalized percussion advice from the Rogers Education Department.

### Percussion Pointers

A free packet of the latest in educational material especially created to fill current voids in percussion education.

Rogers Drums, Dept. of Education,  
1005 E. 2nd Street, Dayton, Ohio 45420

\*Choice of any pearl combination available at no extra cost. Combination shown: Blue Sparkle/Marine Pearl.

Buddy Rich

Louis Bellson



*Dyna-Sonic<sup>1</sup> / Swiv-o-Matic<sup>1</sup> / PowerTone<sup>2</sup> Rogers creates new concepts in percussion. That's why today's top names in percussion play Rogers, choice of the great ones.*

**ROGERS DRUMS<sup>®</sup>**  
U.S.A. creators of new concepts in percussion

CBS Musical Instruments / CBS, Inc.  
1006 East 2nd Street • Dayton, Ohio 45402  
Cable Address: PowerTone

COPYRIGHT Rogers Drums U.S.A. 1987