



 **SONOR**®

**The  
Drummer's  
Drum.**

USA



Founder  
Johannes Link

Consul  
Otto Link

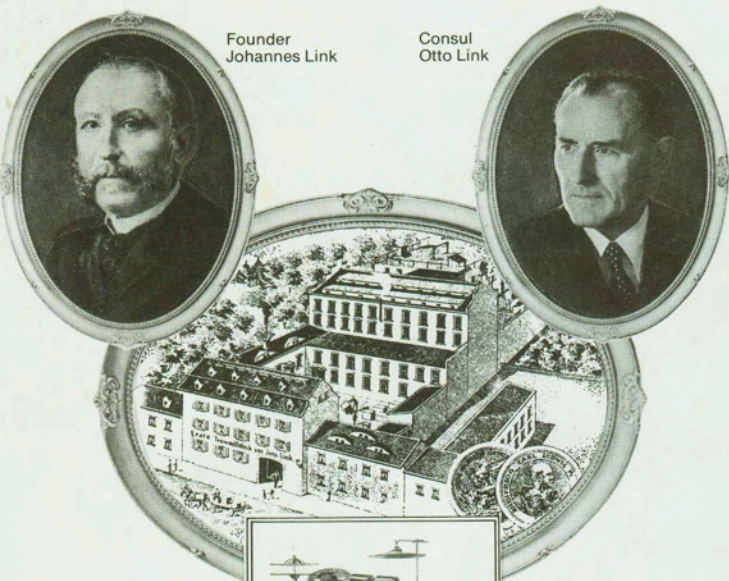

The first  
SONOR factory  
in Weissenfels/Saale

From  
a SONOR catalog  
of around 1920

The SONOR percussion instrument factory was founded on 1st October 1875 by Johannes Link. In 1907 the SONOR trademark was registered with the Imperial Patents Office. When the founder died in 1914 his son Otto Link assumed control of the firm. The Weissenfels factory was nationalised 1950, as a result, a modern, highly efficient plant was built in Aue/Westphalia. When Otto Link, who had become Hon. Consul of Sweden, died in 1955, his son, Horst Link, became President of the company. Today he leads a dynamic young team in which already the 4th Link generation is participating, exporting more than half the total production to approximately 100 countries. SONOR instruments are manufactured to the very highest standards and are today considered by international musicians as "The Drummer's Drum".

SONOR President Horst Link with staff



Drum Session at the 100th Anniversary celebrations



The SONOR factory today

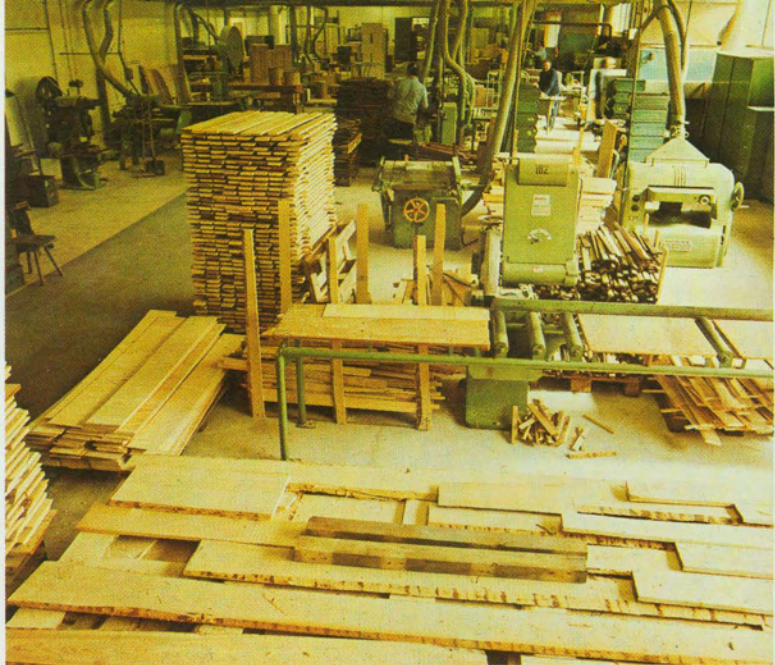

▲ Woodshop

▼ Metalshop

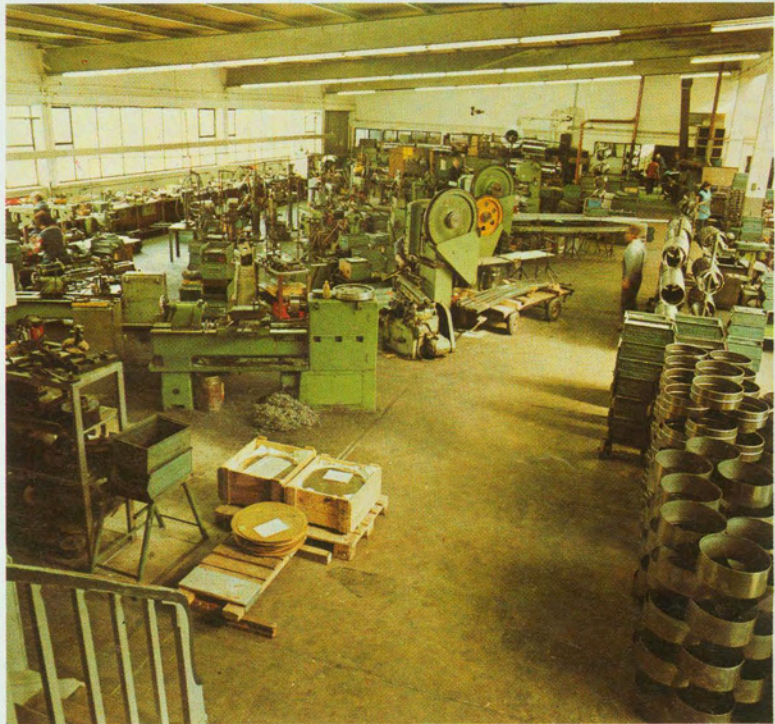

▼ Assembly department





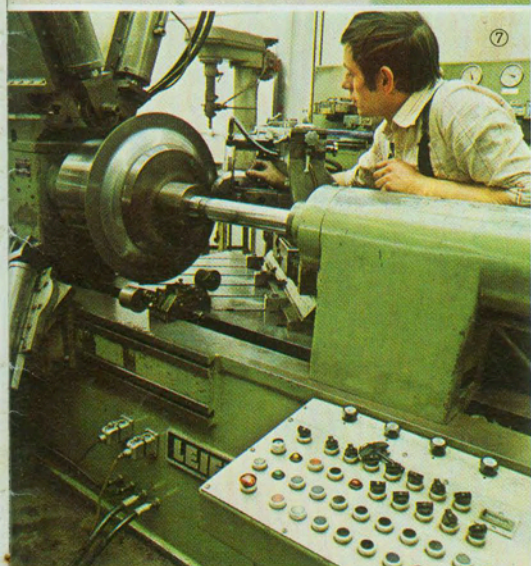
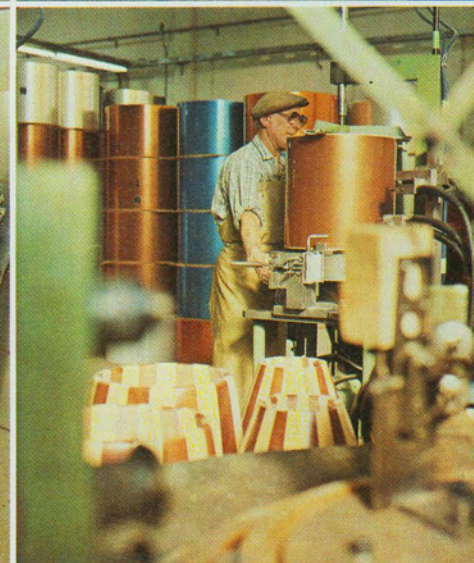
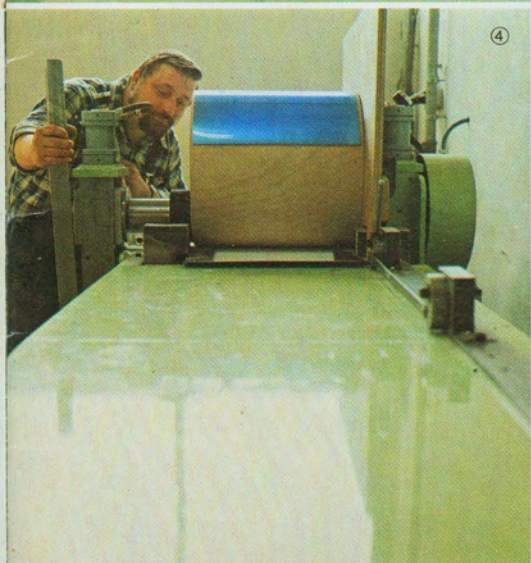
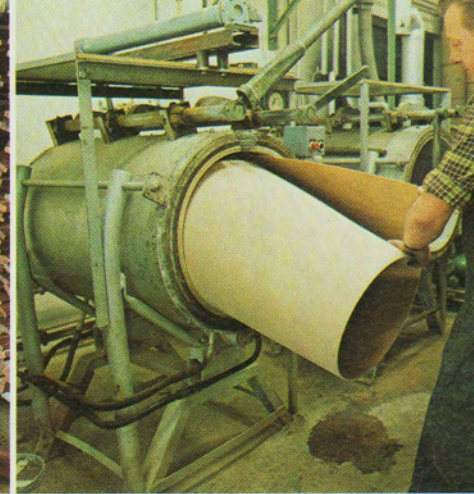
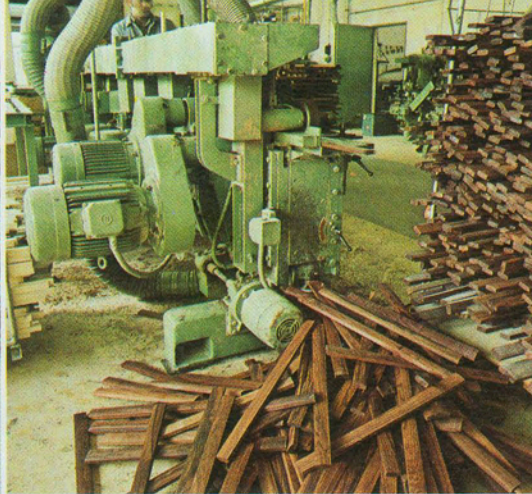

① More than 3000 different raw materials are stored in the warehouse.

② Modern woodworking machines guarantee precise tolerances and labor saving operations.

③ The full vibrating sound shells (9 ply) are formed in special oil-heated presses.

④ Glueing the finish to the shell on a specially developed machine.

⑤ Special presses ensure the durability of the seam of the finish on the shell.

⑥ Precision drilling machines for perfect alignment of all fittings.

⑦ This projecting machine is used for drawing seamless metal shells and profile hoops.

⑧ An automatic polishing machine in the metal-shop.

⑨ A riveting machine in the assembly department.

⑩ A SONOR speciality: "genuine rosewood" veneered shells.

⑪ All SONOR-PHONIC snare drums are tuned by an electronic tuner.

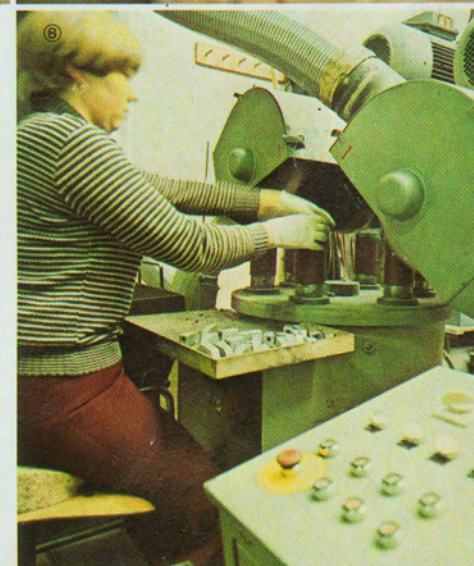



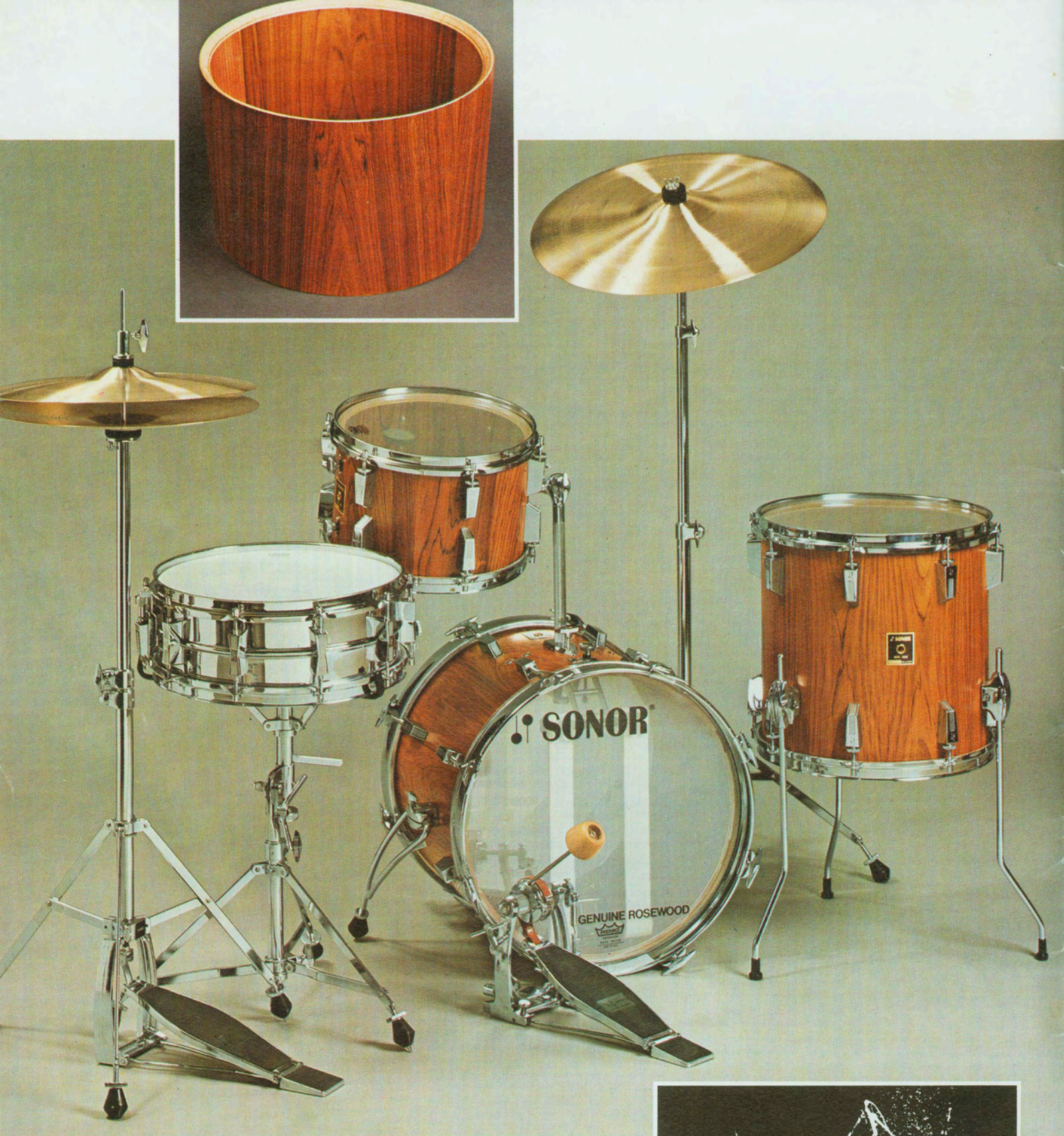

**XK 984 SONOR-PHONIC  
Four-Piece Set**

- G 318** 18" x 14" Bass Drum
- D 500** 14" x 5" Snare Drum
- T 722** 12" x 8" Tom Tom
- T 734** 14" x 14" Floor Tom Tom
- Z 5317** Bass Drum Pedal
- Z 5554** Snare Drum Stand
- Z 5501b** Tom Tom Holder
- Z 5456** Hi Hat
- Z 5232** Cymbal Stand

- Z 5213** Cymbal Arm mounted to Bass Drum available at extra charge (see price list)

Illustrated as XK 1084 special limited edition, rosewood inside and outside, double mufflers, special muffler in Bass Drum.  
Cymbals not included.

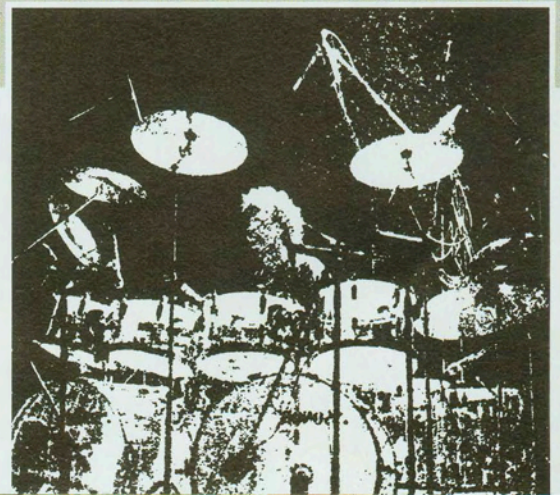





**XK 925 SONOR-PHONIC  
Five-Piece Set**

- G 322** 22" x 14" Bass Drum
- D 505** 14" x 5 3/4" Snare Drum
- T 723** 13" x 9" Tom Tom
- T 724** 14" x 10" Tom Tom
- T 736** 16" x 16" Floor Tom Tom
- Z 5317** Bass Drum Pedal
- Z 5554** Snare Drum Stand
- Z 5503b** Deluxe Double Tom Tom  
Holder
- Z 5456** Hi Hat
- Z 5232** Two Cymbal Stands

Illustrated in KP, Metallic pewter.  
Cymbals not included. Drum Throne  
not included.









◀ **XK 946/1 SONOR-PHONIC  
Six-Piece Set**

- G 324** 24" x 14" Bass Drum
- D 506** 14" x 6½" Snare Drum
- T 723** 13" x 9" Tom Tom
- T 724** 14" x 10" Tom Tom
- T 736** 16" x 16" Floor Tom Tom
- T 738** 18" x 16" Floor Tom Tom
- Z 5317** Bass Drum Pedal
- Z 5554** Snare Drum Stand
- Z 5503b** Deluxe Double Tom Tom  
Holder
- Z 5456** Hi Hat
- Z 5232** Two Cymbal Stands

Illustrated in AS, Acrylic smokey.  
This set illustrated with T 724  
14" x 10" Tom Tom and T 725  
15" x 12" Tom Tom and Z 5224  
Cymbal Stands.  
Consult price list for options.  
Cymbals not included.

**XK 947/1 SONOR-PHONIC  
Seven-Piece Set**

- G 324** Two 24" x 14" Bass Drums
- D 506** 14" x 6½" Snare Drum
- T 723** 13" x 9" Tom Tom
- T 724** 14" x 10" Tom Tom
- T 736** 16" x 16" Floor Tom Tom
- T 738** 18" x 16" Floor Tom Tom
- Z 5317** Two Bass Drum Pedals
- Z 5554** Snare Drum Stand
- Z 5501b** Two Tom Tom Holders
- Z 5460** Bass Drum Hi Hat
- Z 5232** Two Cymbal Stands

Illustrated in KK, Metallic copper.  
This set illustrated with Z 5224  
Cymbal Stands. Consult price list for  
options.  
Cymbals not included.





SONOR®

HERZOG  
HEATING LAMP  
BASS DRUM





**XK 9207/1 SONOR-PHONIC  
Seven-Piece  
"Sound Machine" Set**

- G 322** 22" x 14" Bass Drum
- D 505** 14" x 5 $\frac{3}{4}$ " Snare Drum
- T 713** 13" x 9" Concert Tom
- T 714** 14" x 10" Concert Tom
- T 715** 15" x 12" Concert Tom
- T 716** 16" x 14" Concert Tom
- T 738** 18" x 16" Floor Tom Tom
- Z 5317** Bass Drum Pedal
- Z 5554** Snare Drum Stand
- Z 5503b** Deluxe Double Tom Tom Holder
- Z 5226** Double Tom Tom Stand
- Z 5456** Hi Hat
- Z 5232** Cymbal Stand
- Z 5224** Cymbal Stand
- Z 5227** Boom Arm

Illustrated in KB, Metallic blue.  
This set illustrated with D 506  
14" x 6 $\frac{1}{2}$ " Snare Drum and two  
Z 5224 Cymbal Stands, and without  
Z 5227 Boom Arm. Consult price list  
for options.  
Cymbals not included.





**SONOR**

BEMO  
WALTER KING  
P.A.S. S.p.A.





**XK 9409 SONOR-PHONIC  
Nine-Piece  
"Sound Machine" Set**

- G 324** 24" x 14" Bass Drum
- D 506** 14" x 6½" Snare Drum
- T 710** 10" x 6½" Concert Tom
- T 712** 12" x 8" Concert Tom
- T 713** 13" x 9" Concert Tom
- T 714** 14" x 10" Concert Tom
- T 715** 15" x 12" Concert Tom
- T 716** 16" x 14" Concert Tom
- T 738** 18" x 16" Floor Tom Tom
- Z 5317** Bass Drum Pedal
- Z 5554** Snare Drum Stand
- Z 5503b** Deluxe Double Tom Tom  
Holder
- Z 5226** Two Double Tom Tom  
Stands
- Z 5456** Hi Hat
- Z 5224** Two Cymbal Stands
- Z 5227** Two Boom Arms

Illustrated in KN, Metallic bronze.  
Cymbals not included.





**XK 9212 SONOR-PHONIC  
Twelve-Piece  
"Sound Machine" Set**

**G 322** Two 22" x 14" Bass Drums  
**D 506** 14" x 6½" Snare Drum  
**T 706/8** 6" and 8" x 5½" Concert Toms  
**T 710** 10" x 6½" Concert Tom  
**T 712** 12" x 8" Concert Tom  
**T 713** 13" x 9" Concert Tom  
**T 714** 14" x 10" Concert Tom

**T 715** 15" x 12" Concert Tom  
**T 716** 16" x 14" Concert Tom  
**T 738** 18" x 16" Floor Tom Tom  
**Z 5317** Two Bass Drum Pedals  
**Z 5554** Snare Drum Stand  
**Z 5503b** Two Deluxe Double Tom  
Tom Holders

**Z 5226** Double Tom Tom Stand  
**Z 6204** Bongo Stand for T 706/8  
**Z 5460** Bass Drum Hi Hat  
**Z 5224** Two Cymbal Stands  
**Z 5227** Two Boom Arms

Illustrated in KS, Metallic silver.  
Cymbals not included.









Metallic silver	KS
Metallic copper	KK
Metallic blue	KB
Metallic bronze	KN
Metallic pewter	KP
Metallic lilac	KL
Metallic ruby	KE
High gloss white	CW
High gloss black	CB
Acrylic smokey	AS
Natural beechwood	NA
Genuine Rosewood	PA



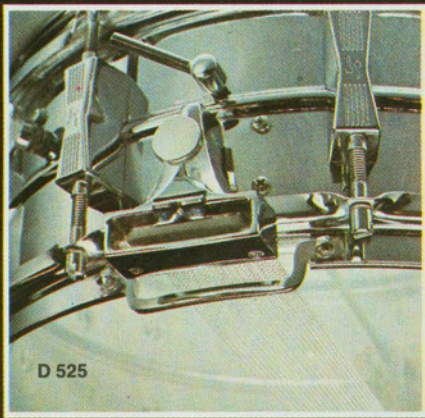

D 525



D 505

#### SONOR-PHONIC Snare Drums

Seamless shell made of ferromanganese steel, seamless profile counter hoops, 20 tension rods with spring-loaded inserts, balanced electronic tuning of both batter and snare heads (Remo Weather King), maximum clearance between snares and snare head and silent action snare release mechanism is guaranteed.

Fine tuning on both sides of the shell, plus, all metal snares (22 special alloy strands).

- D 500 14" x 5"
- D 505 14" x 5 1/4"
- D 506 14" x 6 1/2"
- D 525 14" x 5 1/4" parallel action snare mechanism with axle control.











The new and ultra modern Zildjian factory located in Norwell, Massachusetts, USA, combines a tradition of 350 years with the highest standard of technological progress.

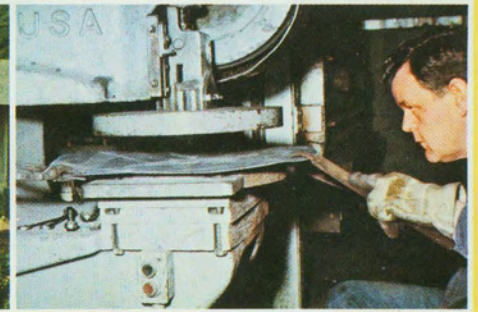

Specially designed Zildjian cup is formed.



Blank is sheared to circular shape and center hole punched for lathing.



Cymbal is lathed by a highly skilled craftsman before final edging.

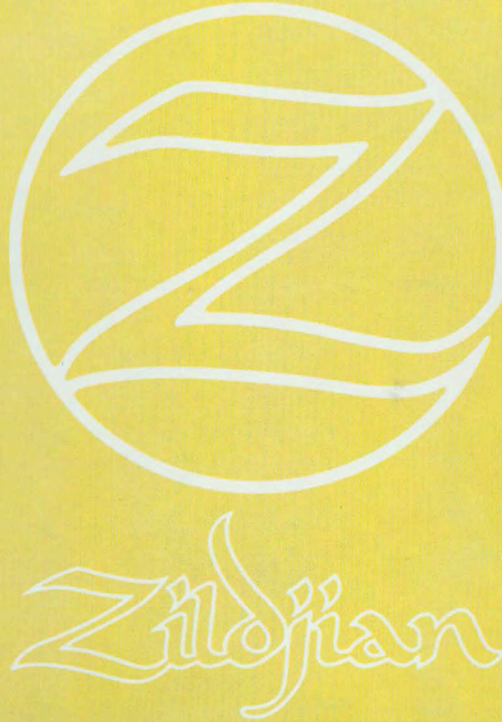

The modern history of cymbals began in 1623 when an alchemist of Constantinople, named Avedis, discovered a still secret process for treating alloys and applied his knowledge to making cymbals. As his fame spread patrons and guildsmen gave Avedis the name "Zildjian" which mean "cymbalsmith". Today, over three hundred and fifty years later, "Avedis" direct descendants are still using the closely held Zildjian family secret process to make the only cymbals made anywhere in the world by Zildjians. Zildjian has a comprehensive range of over 30 different cymbal types and thicknesses, with diameters ranging from 6" to 30". This means that every drummer can find the cymbal which is right for himself, whatever his style. The Zildjian depot for Europe is located in the SONOR factory and has several thousand Zildjian cymbals available for selection.

Zildjian depot for Europe at the SONOR plant.





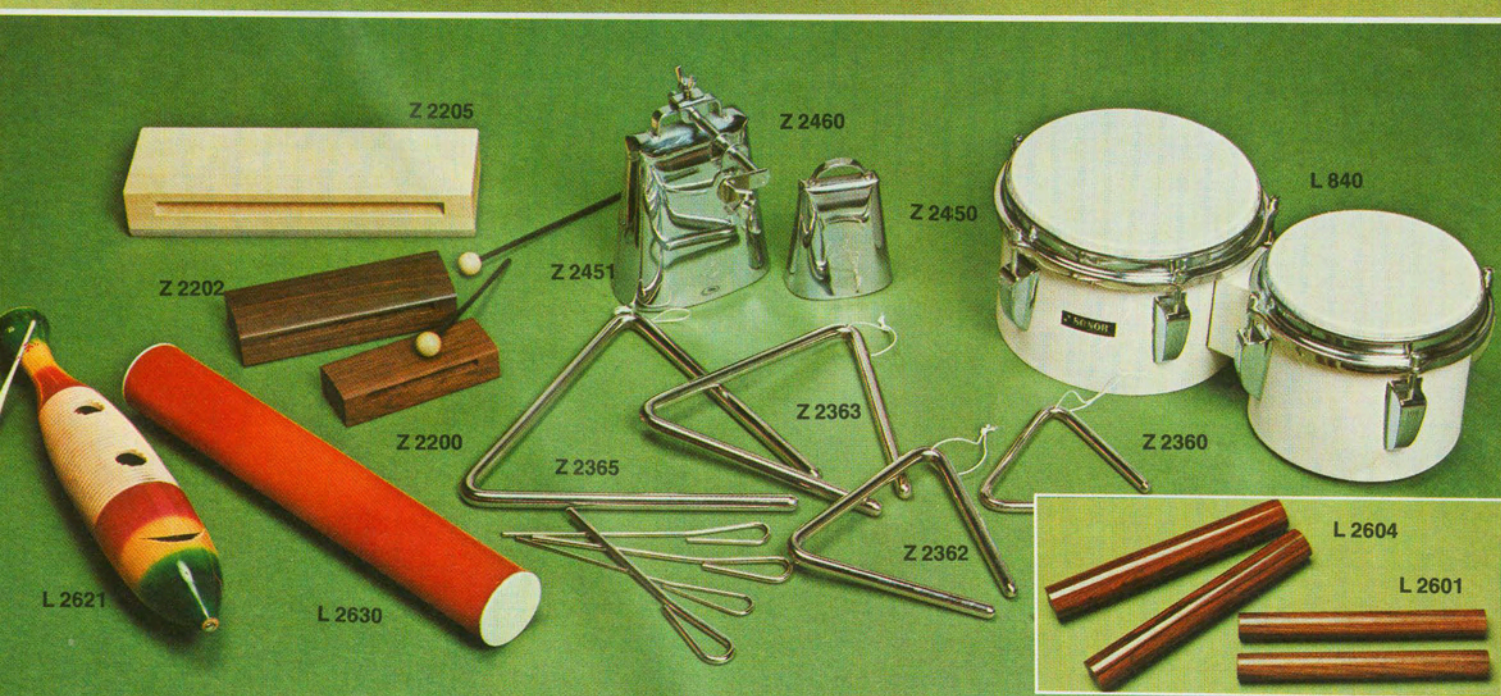





Z 5608 SONOR® Hickory

Z 5609 SONOR® Hickory Nylon Tip

Z 5606 SONOR® Oak

Z 5607 pro-mark Oak Nylon Tip

Z 5607 pro-mark Oak Nylon Tip

Z 5607 pro-mark Oak Nylon Tip

Z 5605 SONOR® Oak

5A

7A

11A

Rock 747

Professional

5A

7A

11A

Rock 747

Professional

5A

7A

11A

Rock 747

Professional

5A

7A

11A

Rock 747

Professional

5A

7A

11A

Rock 747

Professional

5A

7A

11A

Rock 747

Professional

5A

7A

11A

Rock 747

Professional

5A

7A

11A

Rock 747

Professional

5A

7A

11A



Z 5706

Z 5707

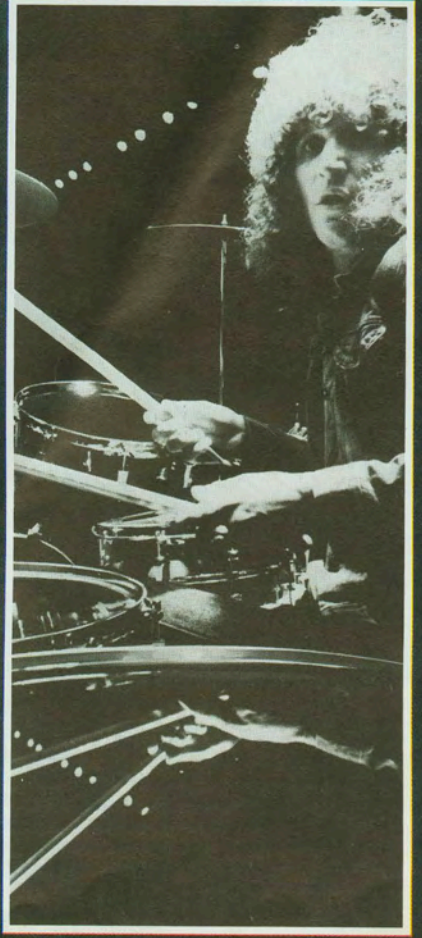

Z 5606 SONOR® Oak

Z 5607 pro-mark Oak Nylon Tip

Z 5607 pro-mark Oak Nylon Tip



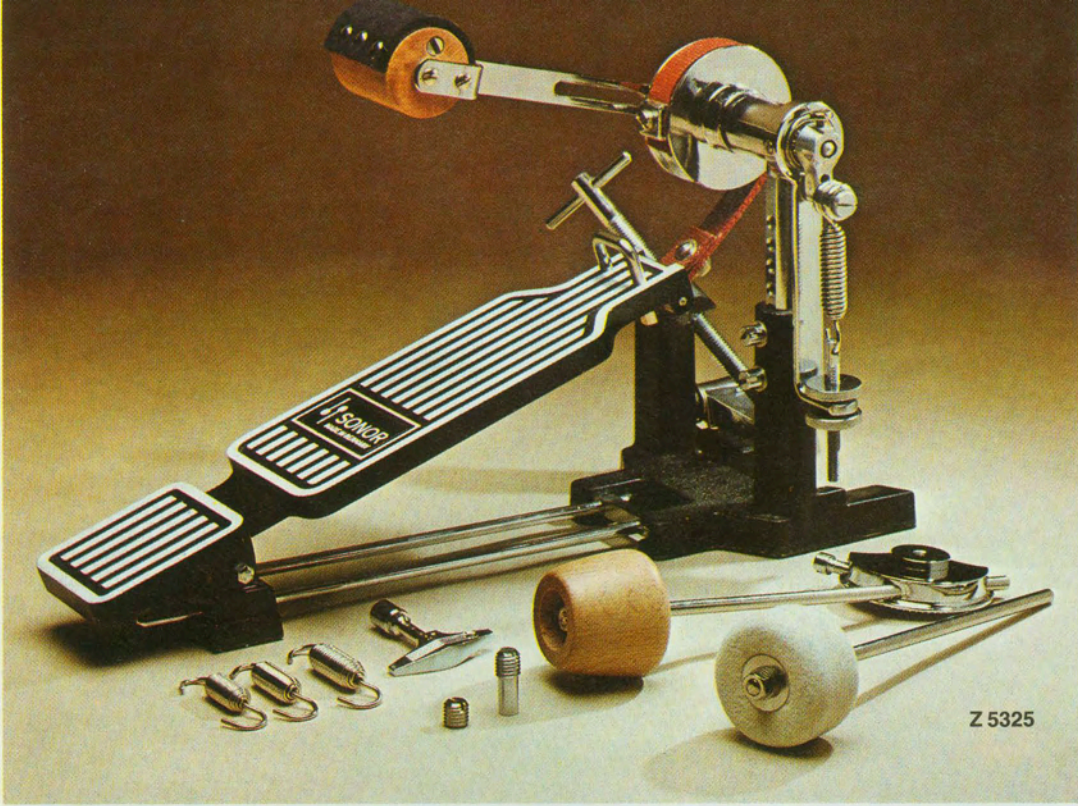

Z 5325

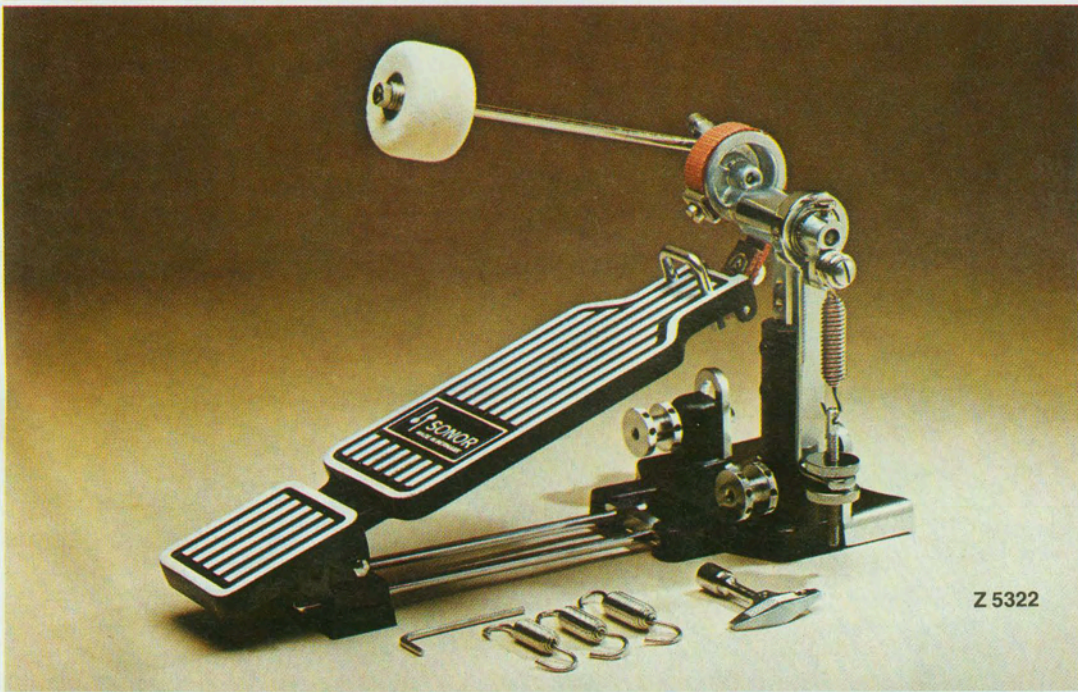

Z 5322

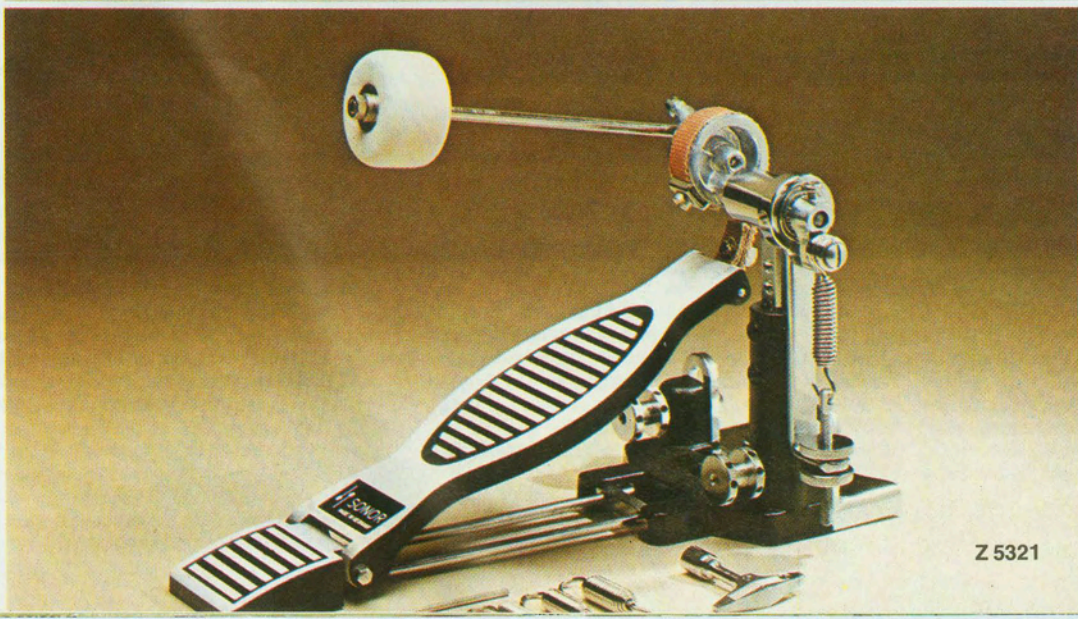

Z 5321



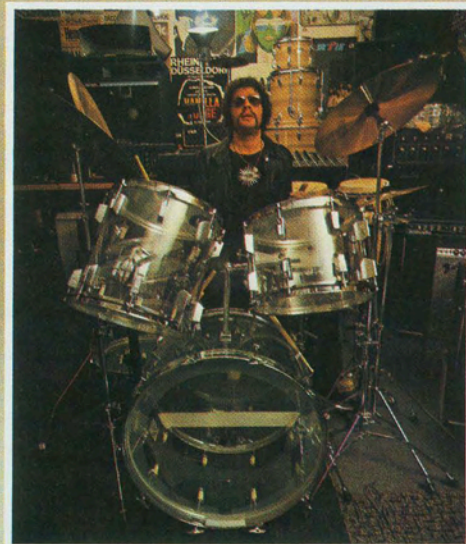

### SONOR-PHONIC Bass Drum Pedals

**Z 5321** This single post eccentric action pedal is multi-adjustable, from the length of the action and throw, to the height and length of the beater. Adjustments can be made by using the standard "SONOR" drum key supplied with each pedal. Three separate springs, hard, medium and soft, are also supplied.

**Z 5322** Specification as Z 5321 except for the following: Single piece foot-plate, adjustable in length and fitted with toe stop.

**Z 5325** "Daniel Humair" single post concentric action pedal is multi-adjustable from the length of the action and throw, to the height and length of the beater. An additional locking plate suitable for use with any standard single post beater is supplied with each pedal. Three extra springs, hard, medium and soft, plus a drum key, are also supplied. The special twin post beater has two playing surfaces, wood and felt. It also features a threaded metal insert, allowing the weight of the beater to be varied to suit individual style. Two extra single post beaters, wood and felt, which are interchangeable, are also supplied. An extra large easy grip locking screw is fitted, allowing swift clamping of the pedal to the Bass Drum.

The single piece foot plate is adjustable in length and is fitted with a toe stop and heavy duty drive belt. This pedal combines all the advantages of pedals No. Z 5317-21-22.

**Z 5317** Two heavy-duty chrome plated support pillars carry a specially designed cross member mounted on long life roller bearings with an adjustable throw/beater mechanism. Three separate springs, hard, medium and soft, are supplied free with each pedal. The finely modelled foot plate is inset with non-slip rubber and there is an extra large easy-grip locking screw fitted allowing swift clamping of the pedal to the Bass Drum.





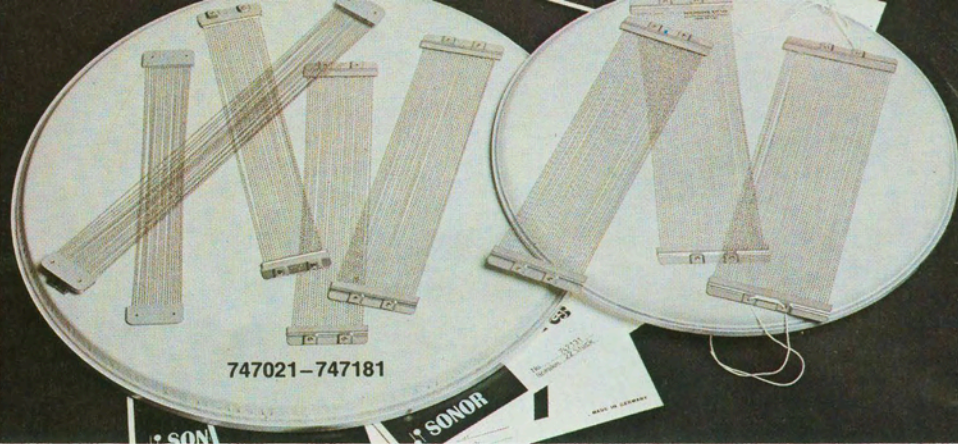
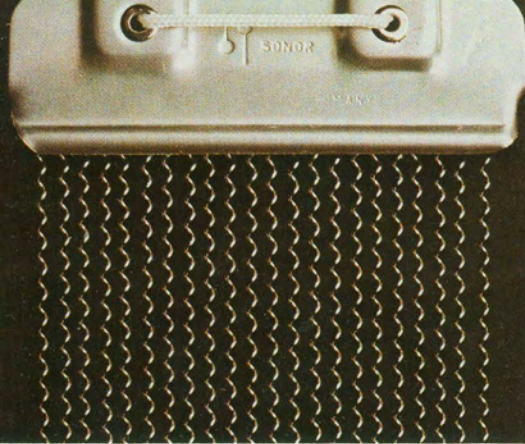

747021-747181

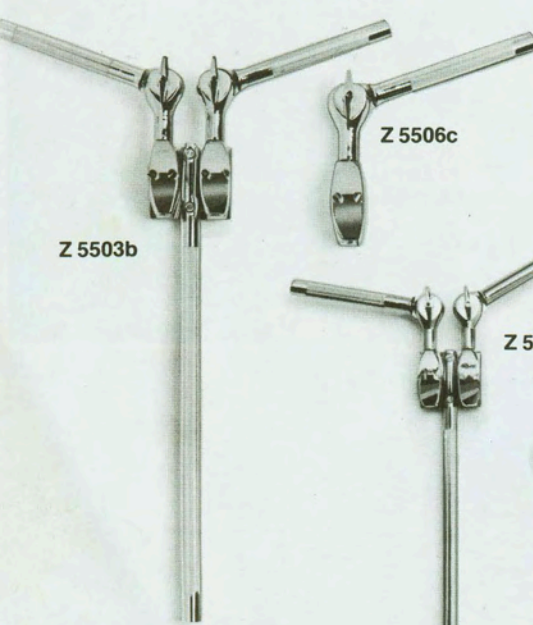

Z 5503b

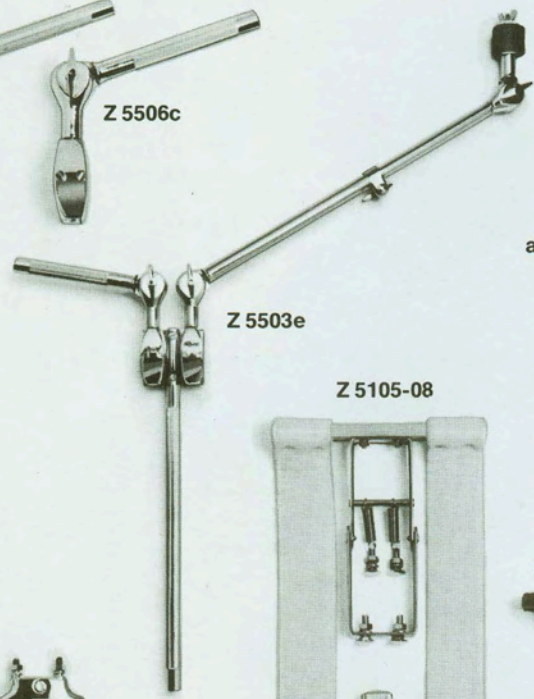

Z 5503e

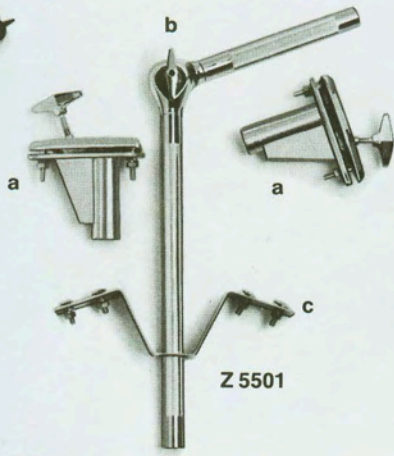

Z 5501

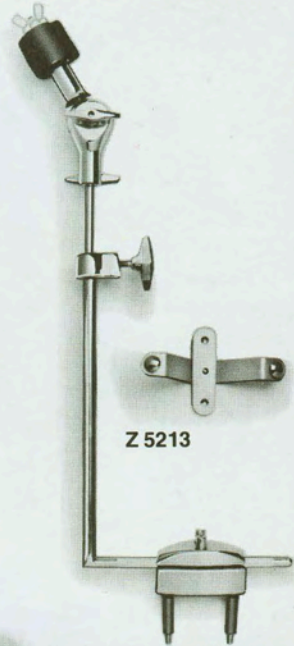

Z 5213

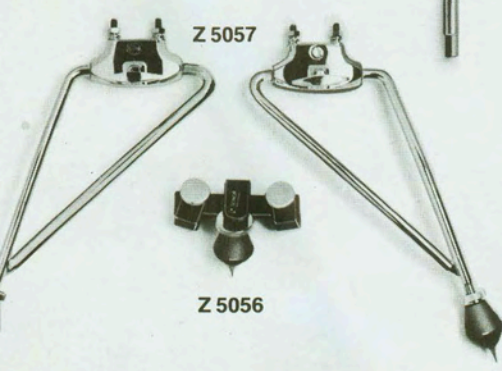

Z 5057

Z 5056

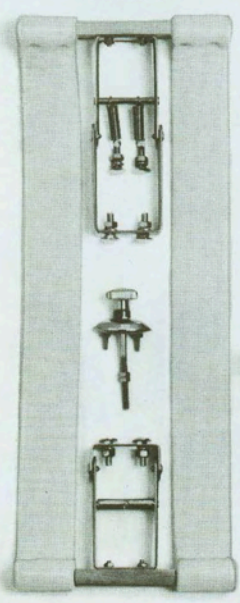

Z 5105-08



Z 5110

Z 5104

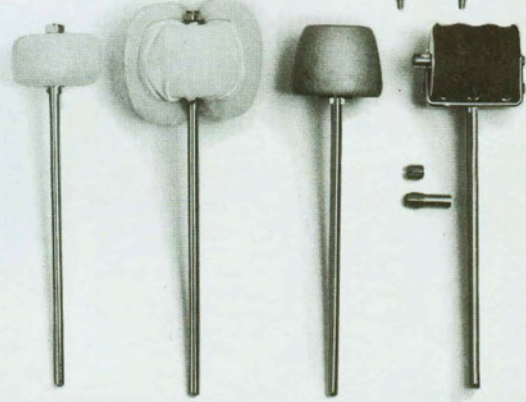

Sch 20

Sch 21

Sch 24

Sch 25



SONOR

REMO





Z 5860-Z 5890

Z 5980-Z 5995





752469

752479

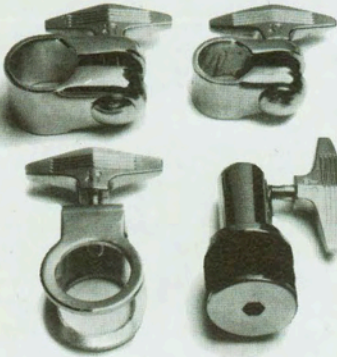

752429

755259



802354

- 752469 clamp 24 mm
- 752479 clamp 19,5 mm
- 752429 clamping device
- 755259 upper cymbal holder
- 802354 butterfly nut M 8
- 155501 set of hi hats springs
- 754191 cymbal rest for hi hats
- 758150 large felt disc for hi hats
- 758130 small felt disc for hi hats
- 758140 felt disc for tilter
- 155601 set of springs for bass drum pedals
- 758340 rubber tip for stands
- 758690 rubber tip for bass drums
- 758400 rubber tip for floor tom toms
- 754831 strap 210 mm for Z 5321/22
- 754681 strap 230 mm for Z 5317
- 754781 strap 270 mm for Z 5325
- 848124 knurled screw with tip for Z 5317
- 753249 connecting rod for bass drum pedals
- 755343 tension rod M 6 x 65
- 843434 knurled nut M 6 for Z 5321/22
- 843424 knurled nut M 6 for Z 5321/22
- 843274 knurled nut M 8 for stands
- 843304 knurled nut M 6
- 843254 knurled nut M 6
- 843484 knurled nut M 10 for bass drums
- 843150 cap nut M 6
- 843050 nut M 6
- 843350 butterfly nut M 6
- 843170 cap nut M 4
- 844030 spring washer 6,1ø
- 802244 butterfly nut M 6
- 802254 butterfly screw M 6 x 15
- 802264 butterfly screw M 6 x 25
- 802294 butterfly screw M 6 x 45
- 802284 butterfly screw M 6 x 35
- 802274 butterfly screw M 6 x 30
- 742014 hook for bass drums
- 801209 tension screw 1/4" x 120 for bass drums
- 745283 insert M 6 for tom tom shell mount
- 745230 insert 1/4" for lugs
- 757350 pressure spring for lugs
- 757190 pressure spring for ratchet link
- 842084 flat round screw M 6 x 40
- 842064 flat round screw M 6 x 35
- 802023 slotted head screw M 6 x 25
- 802043 slotted head screw M 6 x 40
- 801019 slotted head screw 1/4" x 35
- 801029 slotted head screw 1/4" x 46
- 801049 slotted head screw 1/4" x 55



155501



754191

758150

758130

758140



155601



758340

758690

758400

753249



848124



755343

843434

843424

843274



843304

843254

843484

754781



754681

754831

843150

843050



843350



843170



844030

802244

802254

802264

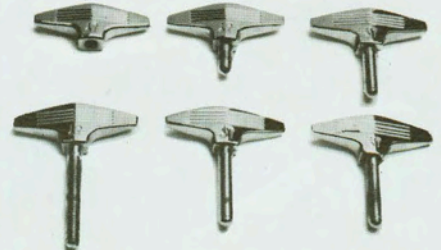

802294

802284

802274

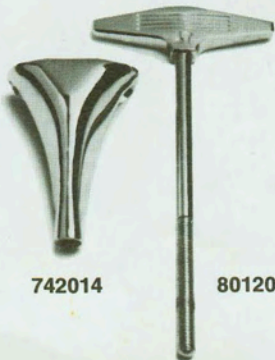

742014

801209



745283



745230



757350



757190

842084

842064



802023

801019

801049

802043

801029



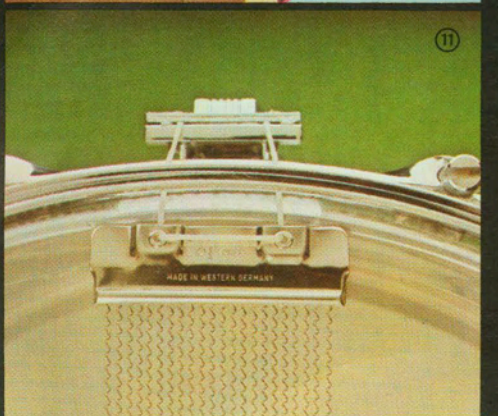
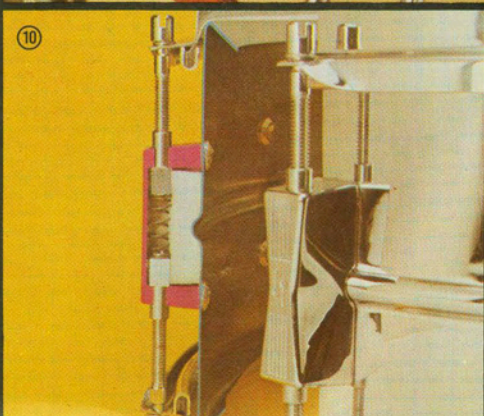
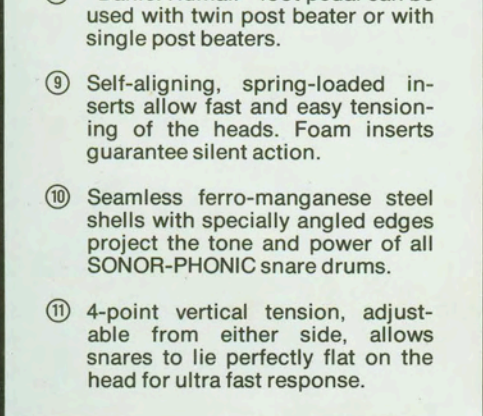
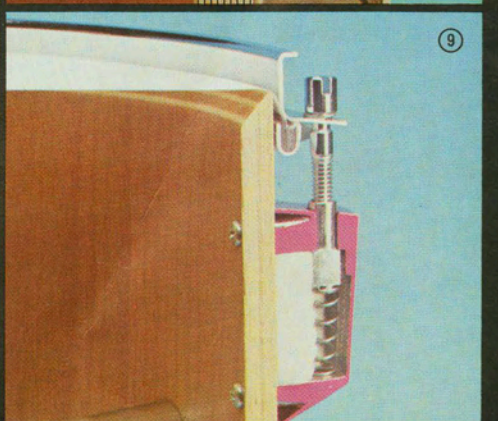
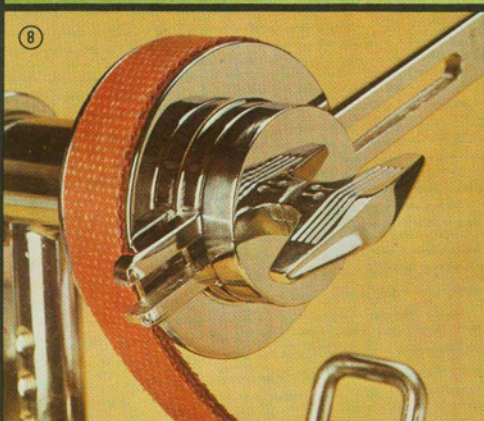
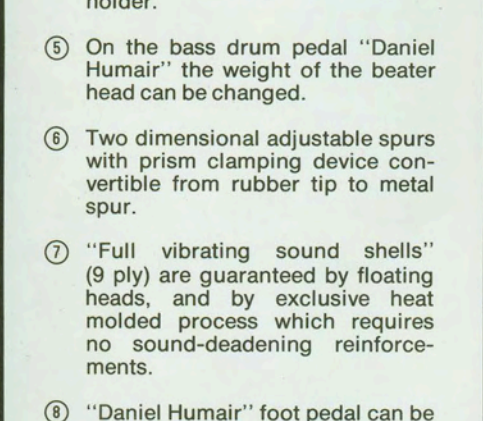
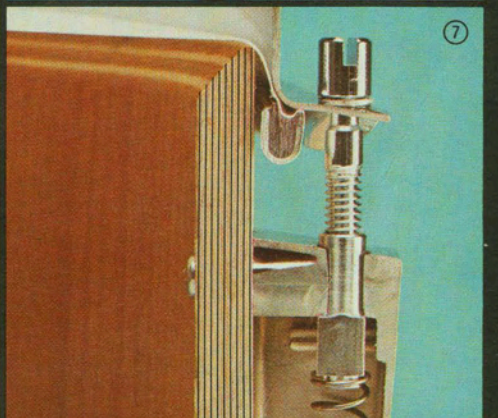
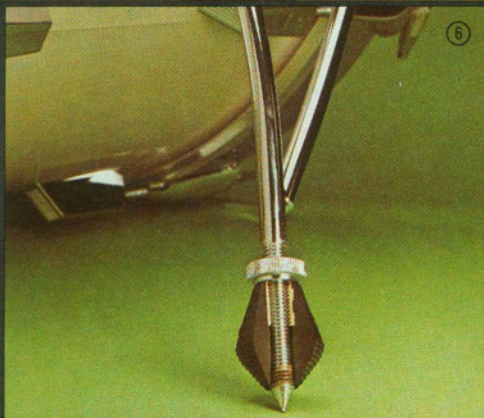
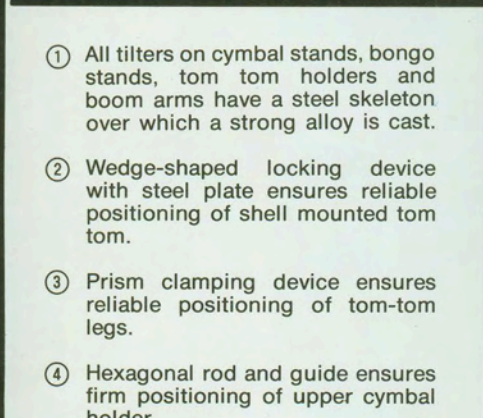
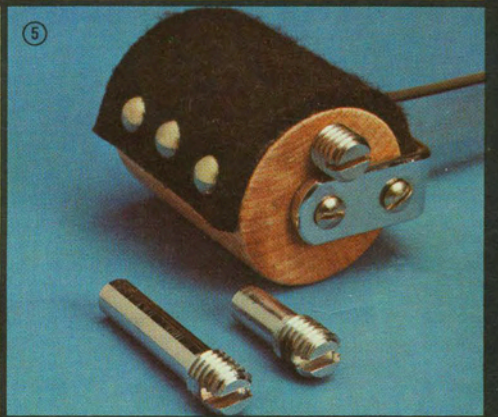
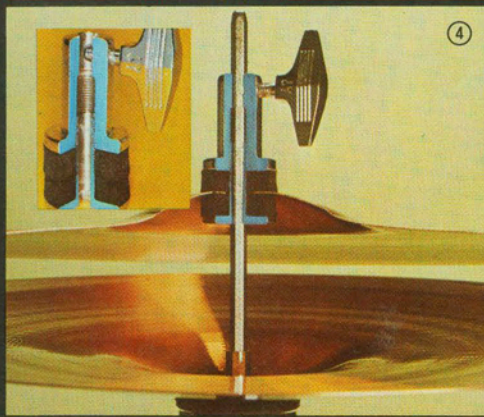
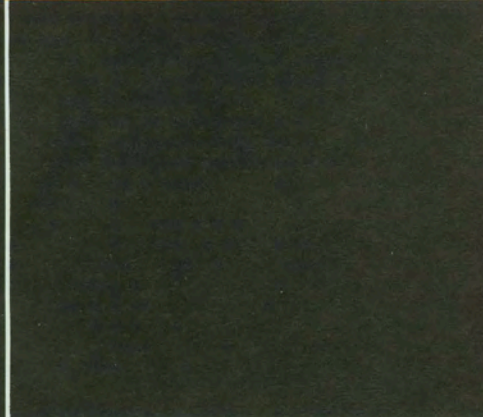
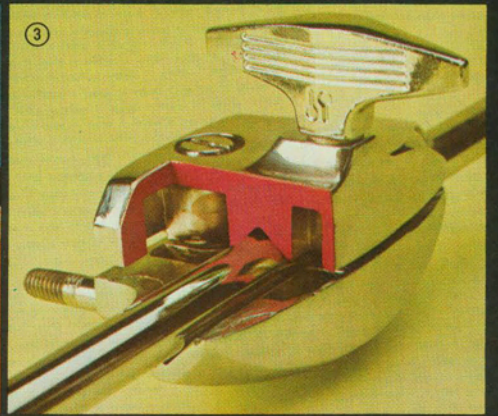
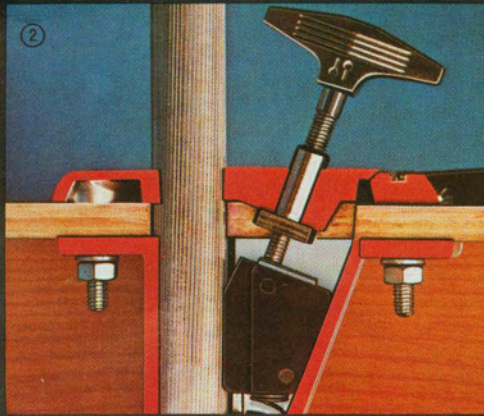
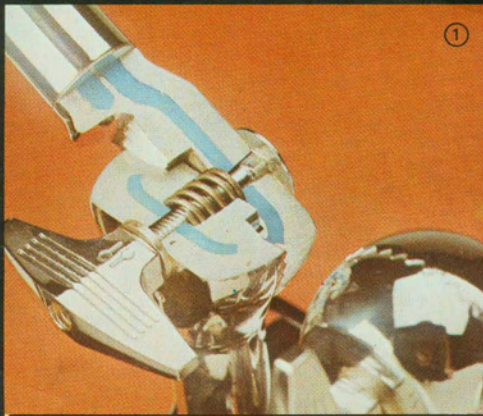

- ① All tilters on cymbal stands, bongo stands, tom tom holders and boom arms have a steel skeleton over which a strong alloy is cast.
- ② Wedge-shaped locking device with steel plate ensures reliable positioning of shell mounted tom tom.
- ③ Prism clamping device ensures reliable positioning of tom-tom legs.
- ④ Hexagonal rod and guide ensures firm positioning of upper cymbal holder.
- ⑤ On the bass drum pedal "Daniel Humair" the weight of the beater head can be changed.
- ⑥ Two dimensional adjustable spurs with prism clamping device convertible from rubber tip to metal spur.
- ⑦ "Full vibrating sound shells" (9 ply) are guaranteed by floating heads, and by exclusive heat molded process which requires no sound-deadening reinforcements.
- ⑧ "Daniel Humair" foot pedal can be used with twin post beater or with single post beaters.
- ⑨ Self-aligning, spring-loaded inserts allow fast and easy tensioning of the heads. Foam inserts guarantee silent action.
- ⑩ Seamless ferro-manganese steel shells with specially angled edges project the tone and power of all SONOR-PHONIC snare drums.
- ⑪ 4-point vertical tension, adjustable from either side, allows snares to lie perfectly flat on the head for ultra fast response.





catalogue 17722  
© Johs. Link KG  
Printed in Germany

EXCLUSIVE DISTRIBUTOR FOR  
UNITED STATES AND CANADA:

**CHARLES ALDEN  
MUSIC CO., INC.**

Southwest Industrial Park  
WESTWOOD, MA 02090  
Phone (617) 326-6040  
Telex 92-4339

AVAILABLE AT: