 **SONOR**<sup>®</sup>

The Drummer's Drum.





# In this Catalogue

*In the constantly changing world of today's music, drummers and percussionists are placing more importance on the quality of their instruments than ever before.*

*A drum set needs to be versatile to allow the musician freedom to play rock, jazz, fusion, country or any other kind of music. Of course, as the technical standards of music have increased, so have the technical requirements of a drum set.*

*This catalogue is designed to comply with these requirements. It shows how a high standard of quality can be achieved by the right mixture of scientific research, modern technology, and a constant exchange of ideas and experiences with you, the drummer.*

*In this catalogue, the professional musician will find everything needed to keep his or her equipment current, while the beginners will find important details to help them select their first set.*

DRUMS LTD. FRANK'S DRUM SHOP  
218 S. WABASH, CHICAGO, IL 60604  
(312) 427-8480

## Table of Contents

Sonor History . . . . .	1	Percussion . . . . .	37
Research . . . . .	2-4	Hardware . . . . .	38-50
Features . . . . .	5-6	Accessories . . . . .	51
Drum Set-up . . . . .	7	Cymbals . . . . .	52-53
Snare Drums . . . . .	8-12	Sticks, Mallets, Brushes	54-55
Signature Series . . . . .	13-20	Drum Heads . . . . .	56
Snare Drums . . . . .	15	Master Series Chart . . . . .	57
Bass Drums . . . . .	15		
Tom Toms . . . . .	18		
Floor Toms . . . . .	18		
Drum Sets . . . . .	20		
Sonorlite . . . . .	21-28		
Snare Drums . . . . .	23		
Bass Drums . . . . .	23		
Tom Toms . . . . .	26		
Floor Toms . . . . .	26		
Drum Sets . . . . .	28		
Phonic and Phonic Plus	29-36		
Snare Drums . . . . .	31		
Bass Drums . . . . .	31		
Tom Toms . . . . .	34		
Floor Toms . . . . .	34		
Drum Sets . . . . .	36		

Conception, Text and Design:  
Oliver Link  
Graphic Design Adviser:  
Werner Harzer, Helmut Schlapp  
Technical Advisers:  
Joachim Sponsel, Werner Saßmannshausen  
Photography: Gerd W. Thiel,  
Dieter Heckmann, Martin Kreutter  
Typesetting: Friedrich, Erndtebrück  
Reproduction and Print:  
Erasmusdruck, Mainz



# The Sonor History

*Johannes Link, born in 1847 in the small Bavarian village Forheim near Nördlingen, was a wood-turner and a tanner. These crafts were the basis for the percussion instruments factory he founded in 1875 in Weißenfels/Saale, in what is now East Germany.*

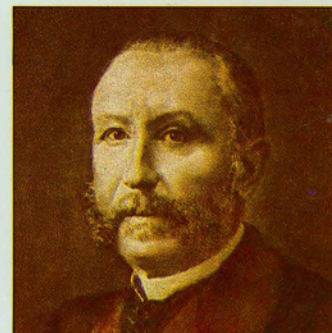

Founder Johannes Link

At the beginning, there was only one employee working at the factory where natural hide drum heads and military drums were produced. However, only a few years later, the small workshop had to be enlarged. By 1900, the factory already employed 53 craftsmen. The company manufactured tympani, concert drums, xylophones, glockenspiels, tambourines, cymbals, triangles and sound effects.

research and development program has been time tested throughout our history, as has the creative efficiency of our craftsmen, musicians, and designers. This blend of old and new, of tradition and progress, is the cornerstone of the Sonor trademark.

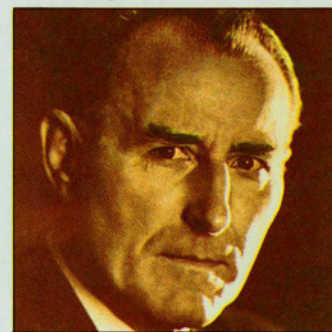

Consul Otto Link



A catalogue issued in 1907 shows for the first time a combined mechanism for playing the bass drum and cymbals, which is a predecessor to the bass drum pedal and hi-hat. The first complete drum sets were built in the early twenties. Their components were already similar to those of a contemporary outfit: bass drum, snare drum, tom tom, cymbal, bass drum pedal and also bottom cymbal, as well as a number of small percussion instruments. At that time 145 employees were working for Sonor. Consul Otto Link, son of the founder Johannes Link and his father's successor, lead the enterprise securely and resolutely through the great depression, war, and post-war turmoils until the factory was expropriated in 1950.



Registration of the Sonor trademark at the Imperial Patent office in Munich on July 1st 1907

President Horst Link

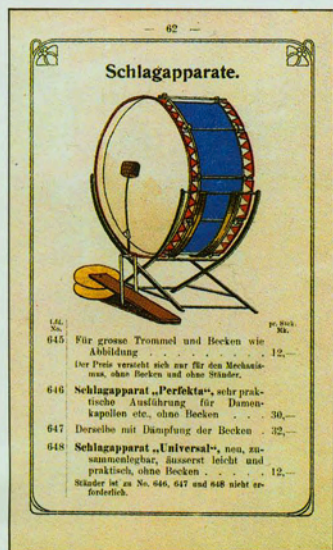
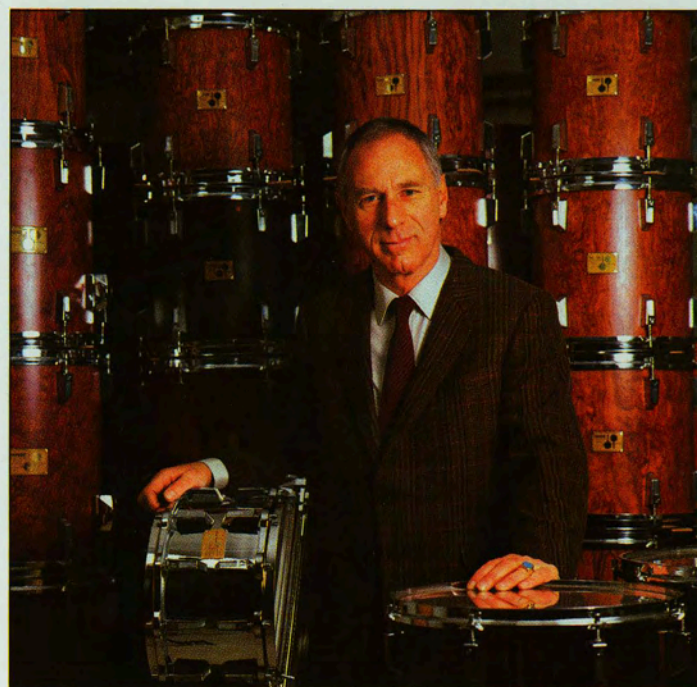

Illustration above: Cover of one the first Sonor catalogues from 1899

Below: Combined mechanism for playing bass drum and cymbals from a catalogue of 1907

This was when he and his son Horst Link moved to the freedom of West Germany to establish a new, modern factory in Aue/Westphalia. By 1955 a catalogue with 100 pages presented a complete range of instruments for drummers and percussionists. Today, Horst Link leads the company together with a dynamic young staff. Today's Sonor instruments are the result of more than 100 years of experience in drum making. Our systematic





# Research

*In the past, acoustic properties of drums had hardly ever been studied. The decisive factor for judging the sound quality of a drum set was and still is subjective, and often influenced by current trends.*

*In order to provide a generally accepted, impartial criterion for classification, scientists of the German Federal Institute for Physics and Technology have been and are continuing to do thorough research on drum acoustics on behalf of the German Association of Music Manufacturers.*

*In their laboratory for musical acoustics, the scientists have answered the crucial question of how the materials, form and size of a drum interrelate and affect the sound quality of the instrument.*

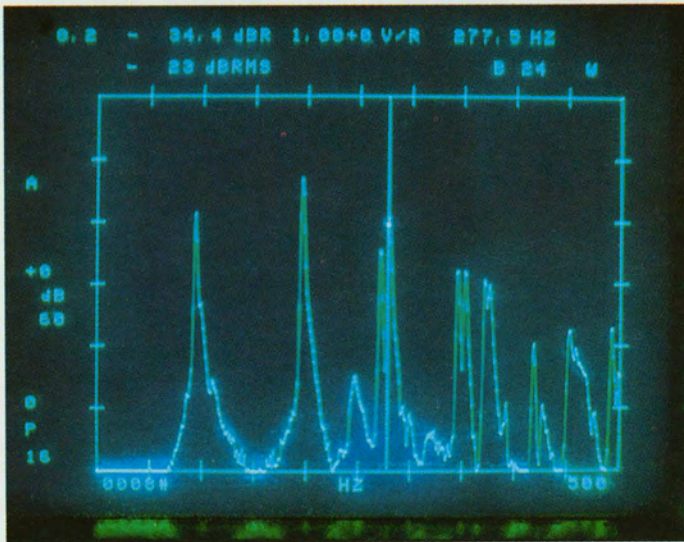

*Frequency spectrum of a drum without resonating head (T 13 CW) with fundamental tone (89 hz) and overtones.*

*Picture on the right: Measuring with a frequency analyzer in a laboratory with non-reflecting walls.*

The sound of a drum as perceived by the auditor consists of a fundamental tone as well as the overtones belonging to it. Basically, it is the fundamental tone that makes us hear low or high pitched sounds. The overtones are responsible for the characteristic sound of the instrument. The more overtones it has, the brighter and more brilliant the sound. With fewer overtones, the sound will be softer and darker.

The head and shell of a drum have different functions which contribute to be sound.

## The drum head

The drums sound starts with the head. The air above and below the head will start to vibrate when it is struck or, as the scientists say, stimulated. This means that the head is not only the sound generator, but also the acoustic projecting element. The better the head can vibrate, the more effective the energy can be transformed into sound.









# Research

Furthermore, the sound quality of a drum is influenced by the material of the specific drum head. Depending on the mass and structure of a head, the overtones have a longer or shorter decay. Drum heads with short overtone decay (such as Pin Stripe, CS) seem to have more distinct fundamental tones and sound softer and darker.

Head Spezifikation	Mass	Thickness	Decay in seconds	
	m/g	h/mm	Fundamental tone 176 Hz/s	Overtones 500 Hz-Terz/s
Ambassador	50	0,3	0,9	2,5
Diplomat	40	0,25	0,8	2,7
Emperor	75	0,46	1,05	2,5
Pin Stripe	62	0,35	1,0	1,4
Controlled Sound	50	0,3/0,4	1,0	1,1

*A comparison of the decay of fundamental tones and overtones of the various types of drum heads. The shorter decay of overtones of Pin Stripe and Controlled Sound heads can be clearly recognized.*

## The drum shell

According to scientific discoveries, the drum shell itself is acoustically passive. The shell does not contribute notably to the sound projection, rather, the frequency of the drum's sound is determined by its dimensions.

The bigger the drum shell, the greater the vibrating air column above and below the head will be. Accordingly, the fundamental tone of a bigger drum will be lower than that of a smaller drum, providing they are tuned the same way. Therefore, the shell influences only the vibrations of the head and its sound projection. In order to fulfill this function in the best possible way, the shell of a drum has to meet the following requirements:

- The shell must not vibrate, in order not to deprive vibration energy of the drum head by its own vibrations.
- The shell must have a high flexional resistance: the higher the flexional resistance, the less chance of the shell producing its own vibrations.
- The shell must have a great mass, thus making the decay of the drum sound to a large



*Scientific research on drums: Measuring with a Third Octave Analyzer and a Beat Frequency Oscillator*

extent independent from the way it is fixed to holders and stands. Furthermore, it favors an efficient projection of the fundamental tone.

- The frictional loss at the inside of the shell has to be kept as small as possible. A low frictional loss means a more effective transformation of the head vibrations into sound.
- The edge of the shell must be finished in such a way that the vibrations of the head are muffled as little as possible. Friction at the edge of a shell causes a muffling of the high sound components. The least possible muffling is achieved with a narrow edge, whereas a wide edge causes a stronger muffling. The harder the material of the shell, the less the overtones are muffled. This is the reason why snare drums with metal shells have a more distinct range of overtones than those with wood shells.

The stability of the drum shells is very important, as only a solidly built shell with hard edges allows optimal vibrations of the drum head.

## Wall thickness of the drum shell

Apart from the dimensions of the shell, the wall thickness also influences the sound quality of the fundamental tone.

- The basic frequency will be more muffled when the shell has a thin wall, so that the upper frequencies emerge. The sound seems to have more overtones, to be more brilliant and sustaining.
- Shells with a thicker wall and equipped with the same type of heads have the same spectrum of overtones as thin shells. However the projection of the fundamental tone is better. The sound seems to be softer and fuller.

## Bibliography

Prof. Dr.-Ing. Jürgen Meyer:  
Dr.-Ing. Ingolf Bork:  
Entwicklung von akustischen  
Optimierungsverfahren für Stabspiele  
und Membraninstrumente

Dr.-Ing. Ingolf Bork:  
Das Schwingungsverhalten von  
Trommelfellen und -kesseln  
Das Musikinstrument, Heft 1, 1984

Prof. Dr.-Ing. Jürgen Meyer:  
Akustik und musikalische  
Aufführungspraxis

Michael Dickreiter:  
Der Klang der Musikinstrumente

Prof. Dr. Juan G. Roederer:  
Physikalische und psychoakustische  
Grundlagen der Musik

Steven Walker:  
Analytic Drum Tuning

Photographs by courtesy of the German  
Federal Institute for Physics and  
Technology, Braunschweig



# Features

## Sonor wood shells

### Basis for a better sound

Beech and birch, being two of the worlds strongest timbers, are the basic materials for all Sonor drum shells. Both woods have a uniform density, so that their surfaces are smooth, firm and resistant to wear. Because of their outstanding acoustic properties and their flexibility and resilience, they are ideally suited for the production of drum shells.

### Construction of the wood shells

The highly solid Sonor shell is produced by a special forming procedure. This process includes the cross laminating of the separate plies. There are also no sound restraining reinforcement hoops or shell supports, so the shell has a minimum of vibration and the same level of stability at every point.

### "floating heads"

In order to allow a drum head vibration unaffected by secondary

*The high level of stability of all Sonor drum shells is ensured by cross-laminating several plies of wood.*

*Illustrated below is a 12-ply Signature shell*

## Physical properties of various types of wood used in drum making

Type of wood	Gravity g/cm <sup>3</sup>	Modulus of elasticity N/mm <sup>2</sup>	Pressure resistance N/mm <sup>2</sup>	Flectional strength N/mm <sup>2</sup>	Hardness N/mm <sup>2</sup>
Bubinga	0,88	15.800	66	132	
Beech	0,69	14.270	56	116	34
Birch	0,67	14.780	60	121	29
Lauan*	0,64	13.250	51	94	22
Maple	0,61	11.720	48	98	23
Poplar	0,43	9.680	37	71	12

Modulus of elasticity: Factor of proportionality for the inrerrelation of power and bending strain

Pressure resistance: The pressure applied to the wood until the point of breaking

Flectional strenght: The bending strain applied to the wood until the point of breaking

Hardness: Measure for the strain when pressure is applied perpendicular to the grain

N/mm<sup>2</sup>: Power / Surface

\* Red Lauan is sometimes called "Philippine Mahogany", although it is not mahogany (Informationsdienst Holz, No. 5)

noise, we use the principle of floating heads, which is also used for concert tympani. The sizes of the Sonor shells and rims prevent a contact of the drum head rim to the shell. Measurements show that

vibrations are projected in the best possible way when there is an angle of 45° from the edge of the shell to the head. Accordingly, the top and bottom edges of Sonor shells are bevelled at 45°.

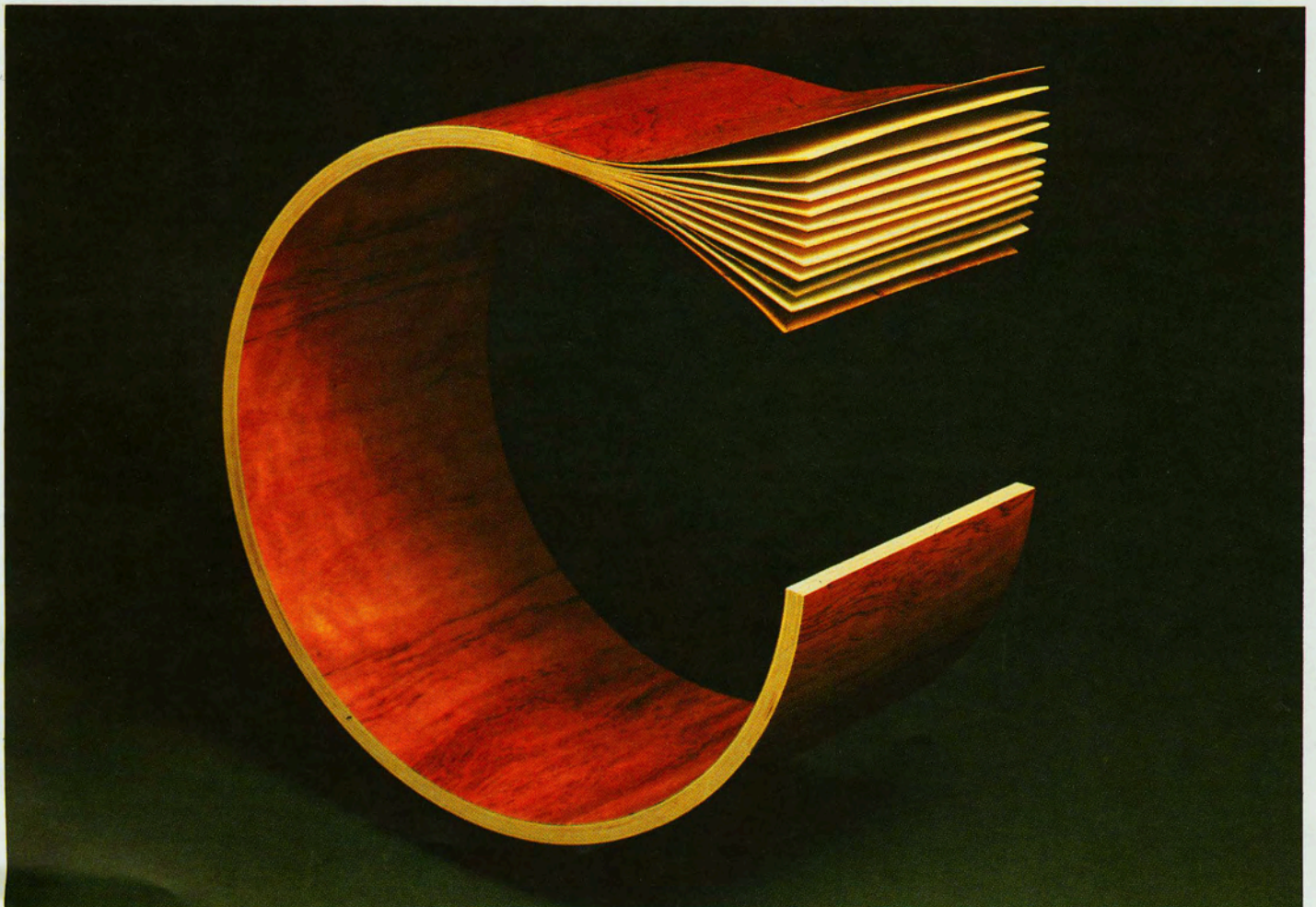



# Features

## Manufacture of metal drum shells

Sonor metal shells are made seamless of ferro-manganese steel. Like the wood shells, these shells are designed to have minimal vibration of their own, allowing an optimal vibration of the head. A flat steel disc is formed into a perfectly round shape on a projection machine. Cold forming ensures a regular wall thickness and a high stability of the shell. In the following galvanization process, every shell is first copper-plated, then nickel-plated and finally chrome-plated.

## Fittings

The drums, rims, lugs and tension screws are parts that take the most stress. Therefore, special care is devoted to their production. Similar to the snare drum shells, the rims are formed seamless from ferro-manganese steel. The flanged rim with its beaded upper edge allows clean rimshots and prevents a high breakage of sticks.

Sonor tension screws for snare drums, tom toms and floor toms have the characteristic slotted cylinder head and can even be turned with a coin if there is no key at hand.

The inside of the drum lugs consists of:

- ① Thread housing made from nonferrous metal, to prevent high wear
- ② "Snap-lock" fixing the thread to prevent the head from going out of tune
- ③ Tension spring as a bedding for the thread-housing
- ④ Foam lug insert to prevent rattling

## "Snap Lock" (patented)

The "Snap Lock" system, developed and patented by Sonor, is an important innovation in drum making. It prevents the tension screws from loosening and causing the drum head to come out of tune during play. The system is as simple as it is effective.

A clamping ring above the thread housing is pressed against the tension screw, which is flattened on two sides. When the screw is

tightened it will lock at every half turn, securing its position. The tension screws of the snap lock can be turned easily with a Sonor drum key, in contrast to the lock nut system which is a difficult and more time consuming process. For best results in head changing we recommend spin key Z 5070. For tuning we recommend keys Z 5071 and Z 5072.

## Shell mounts

The shell mounts on tom toms and bass drums are holders in two respects. First, on all Sonor shell mounts the tom holders are fixed by tightening a wing screw down on a spring loaded and steel reinforced nylon wedge. The shell mount holds horizontally by the wedge, and is doubly secured by means of a fix clamp.

Second, the mount is held securely on the drum by 2-point drilling of the toms and 4-point drilling of the bass drum. The mount has a full outside and inside allowing tremendous weight to be mounted on the bass drums without the mount loosening.

## Bass drum spurs and floor tom legs (DGM)

Bass drum spurs and floor tom legs are adjusted by prism clamps, which enclose a section of the spur or leg making slippage virtually impossible. The prism clamp itself is fixed to the shell at 3 points. The spurs are of a superior "non-creep" design, and are quickly adjustable from rubber feet to metal spikes to keep the bass drum rigid on any surface. The floor tom legs are equipped with solid rubber feet.

*Cutaway of a Sonor lug*

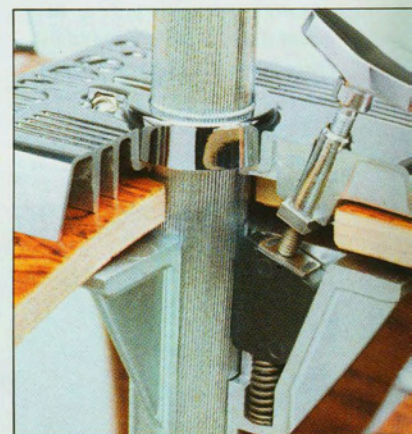
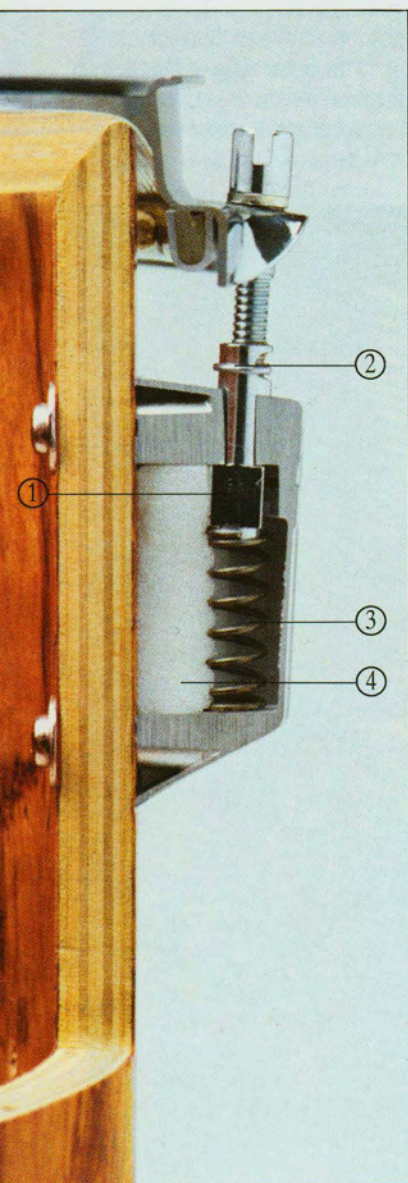

*Cutaway of tom tom mounts (top) and bass drum mounts (center)*

*Prism clamp for floor tom legs (bottom)*



# Drum Set-up

*The drum set is a very personal instrument. It has to meet the individual requirements of every drummer. In most cases the purchase of a complete drum set means a large investment planned for several years of use. The person who wants to make that decision should therefore be able to answer a number of important questions:*

What kind of music will you be playing?

When choosing the equipment, the kind of music to be played and the number of musicians playing in the band should be taken into consideration. For example, in most cases a 4-piece set with 18" bass drum, 5 $\frac{3}{4}$ " snare drum, 12" or 13" tom tom and 14" floor tom will be suitable for the traditional jazz band.

Playing in a rock band, however, requires a drum set with larger drums.

What kind of sound do you want?

Every drummer has individual ideas regarding sound. This is why Sonor offers 5 types of drum shells with different sounds. When these are combined with the many types of drum heads available there is a nearly unlimited variety of drum sounds.

Does the drum set suit your technique?

The individual abilities of the drummer are the criteria for the choice of equipment. The beginner should start with a standard set, consisting of bass drum, snare drum, one or two tom toms and floor tom. The set can later be enlarged with additional drums.

Where will you play your drums?

Unfavorable surroundings sometimes prevent the set-up of a large drum set. There are alternatives to the traditional set-up which help to avoid problems in a narrow room: the double bass drum pedal HLZ 5382, the Vario-Clamp

system, the quadruple tom tom holder Z 5518b, as well as the double cymbal stand Z 5278.

How will you transport and store your drum set?

Covers and cases help to preserve the value of a drum set for a long time. If the position of the set is not changed very often, it is sufficient to use drum covers for transport. For drummers who travel a lot, the purchase of fibre cases will be worthwhile.

Before composing a drum set, one should know the different components and their use:



**The Snare Drum** is the most important component of a

drum set. It not only has to meet very high standards, but also very different requirements. Whether it is being played delicately with brushes, or standing up to rimshots, the sound of the complete drum set is influenced by the snare drum. The purchase of a good snare drum is a wise investment.

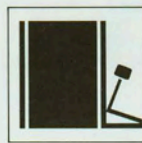

**The Bass Drum** together with the snare drum, is the foundation of a drum set. It is

the largest instrument with the deepest tones, so that we recommend you choose the size of the other drums in accordance with the bass drum.

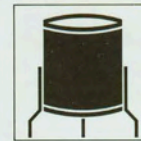

**The Tom Toms and Floor Toms** supplement the sound of a drum set.

Due to the large assortment of different sizes, the tom toms will be regarded as a considerable enrichment to the sound of a drum set.



**The Cymbals** are used for rhythmical accentuation. The basic

equipment comprises Ride, Crash and a pair of Hi-Hat cymbals. The set can be enlarged with additional sound and effects, as, for example, Chinese, Flat Ride and Splash cymbals.



**The Hardware** consists of a bass drum pedal, hi-hat, cymbal stands,

tom tom holders or tom tom stands, snare drum stand and drummer's throne. With multiple holders, Vario-Clamp and stand combinations, a variety of set-ups are possible.



**Drum Heads and Drum Sticks** have a considerable

influence on the sound of a drum set. Thickness and quality of the heads, as well as the material and weight of the sticks are of crucial importance.



# Snare Drums

Sonor has a long tradition of manufacturing snare drums, which began in the 1890s. A catalogue from 1899 contains more than 20 different models of snare drums, some of them with genuine brass shells and nickel plated fittings.

The turbulent musical developments of the twenties and thirties inevitably lead to improvements and innovations in the making of drums. The "Favorit" model of 1930 already had most of the technical features of a modern snare drum: "Throw-off" snare strainer, fine adjustment of the snares as well as "floating heads".

An especially creative phase began in the early fifties. Sonor technicians designed drums for the future, such as the first snare drum with a central tuning system and a parallel internal muffler, unique at the time.

To this day, the demands on the sound and quality of a snare drum have constantly increased. All of the snare drums shown in this catalogue are manufactured by experienced craftsmen with the help of modern technology.

## Snare Drums for all sounds

There are 27 different Sonor snare drum models, with shells from beech or birch, or ferro-manganese steel. Everybody will find a snare drum to suit his or her personal idea of sound, from

the clear, transparent sound of the super-flat D 420 to the forceful volume of an HLD 588.

## Which snare drum for which sound?

The metal shell produces a sharp, responsive sound, while the wooden shell generates a fuller, more mellow sound. The deeper the shell, the more volume it projects. The thickness of the shell also influences the sound. Drums with thick shells produce a soft sound with few overtones, while thin shells have distinct overtones and therefore a more brilliant sound.



Sonor snare drum shells: seamless ferro-manganese steel shell, 12-ply Signature Heavy shell, 12-ply Signature Light shell, 12-ply Sonorlite birch shell, 9-ply Phonic and Phonic Plus beech wood shell

The "Favorit" snare drum of 1930

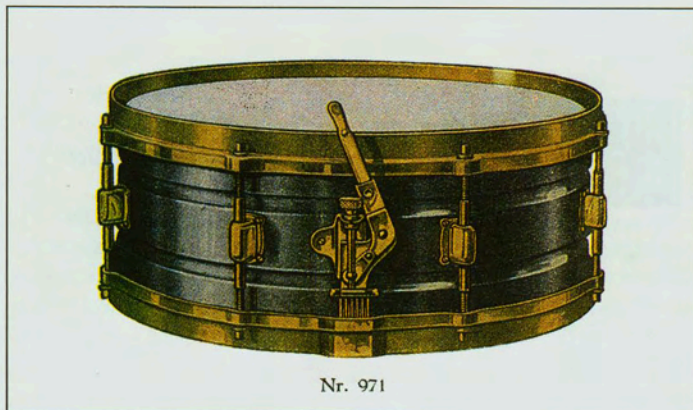

Nr. 971





Signature snare drum HLD 580 with parallel snare action

① turnable lever ② two adjustments for infinitely variable snare tensioning

③ triple axle guide ④ axle for parallel action ⑤ height adjustable housing

### The Snare Strainers

The snare strainer must allow the quick and noiseless lifting and release of the snares, while at the same time regulating their resting and tension. There are four different types of Sonor snare strainers:

### The Parallel Snare Action

for Signature and Sonorlite Snare Drums was made to satisfy the highest demands. Due to the parallel movement, the snares

remain under tension. Every single strand is resting exactly on the snare head and guarantees a precise response of the snare drum at any dynamic level.

### The "Throw-off"

for Phonic snare drums is the most popular model. The strainer and butt end allow the snares to be adjusted from either side. Nylon strings have the advantage of a 4-point suspension which allows perfect balancing of the tension.



"Throw-off II" snare action

### The "Throw-off II"

for D 508x, D 518x and LD 547x is an advanced model of the "Throw-off" release. The snares surpass the edge of the head, so that the whole length of the strands is resting even better on the snare head. Furthermore, muffling is avoided since the metal plates of the snare mechanism do not touch the snare head.

### The Standard Snare Strainer

for the D 420 is a time-tested, easily controllable system. The tension of the snares is adjusted with a knurled screw at the snare butt.



"Throw-off" snare action



# Snare Drums

Die-cast rims for full, heavy sound

24 tension screws permit exact tuning of the batter head and snare head

"Snap-lock" prevents loosening of the tension screws

Drum lugs muffled with a foam lug insert and threads bedded on springs

Turnable lever for easy throwing off and quick lifting of the snares.

Seamless, 8" deep shell from ferro-manganese steel with high flexional strength and outstanding sound volume

Parallel snare action allows exact resting of the snares on the snare head and precise response at every dynamic level

Infinitely variable tensioning with adjustments on both sides of the snare strainer

Equipped with "Rock" as well as "Jazz" snares with 22 or 24 strands from stainless steel

Triple axle guide relieves the shell from high stress and protects the snares from damage

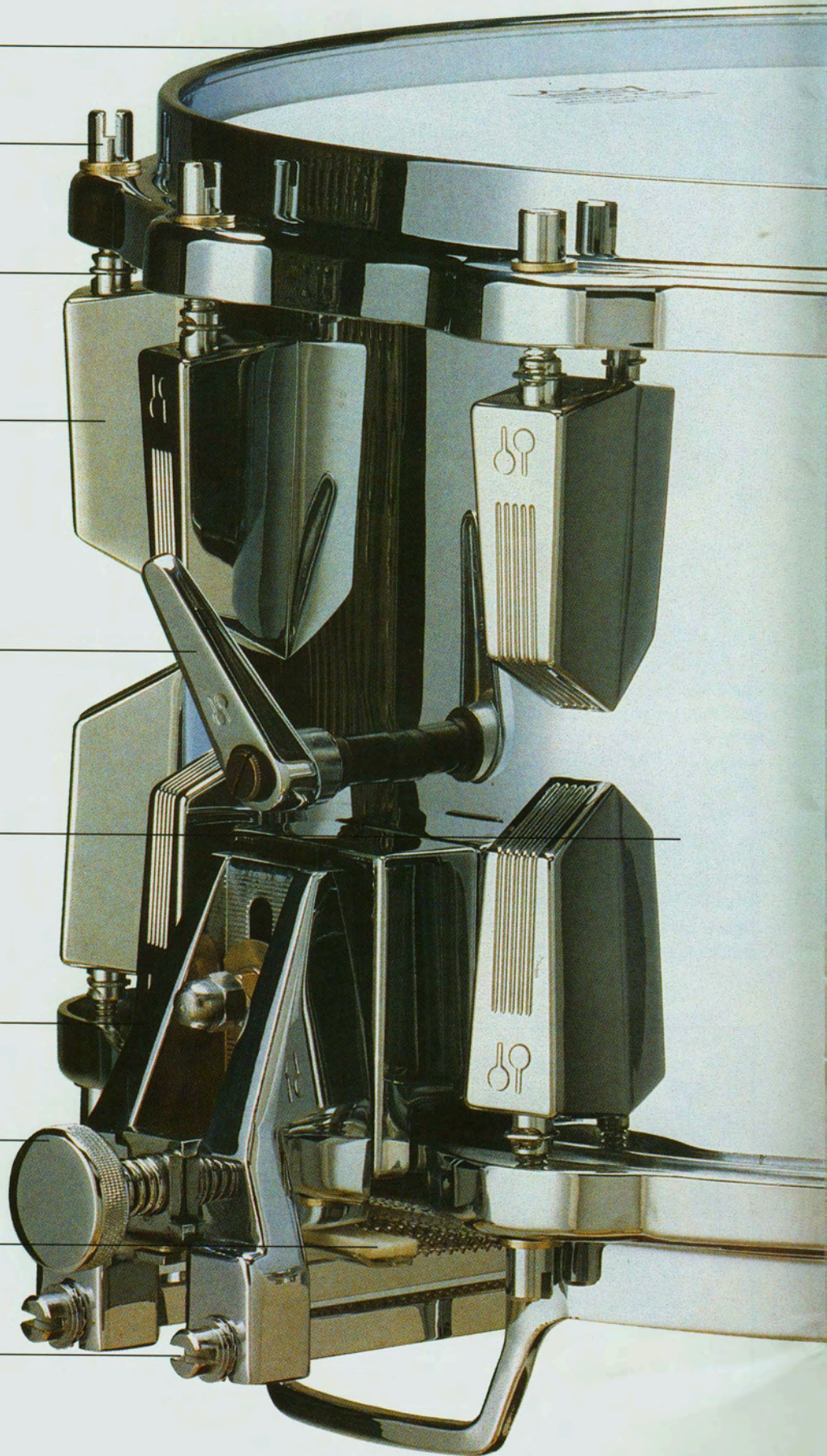





HLD 588 Signature Snare Drum  
14" x 8"





HLD 580 RH



HLD 582



HLD 588

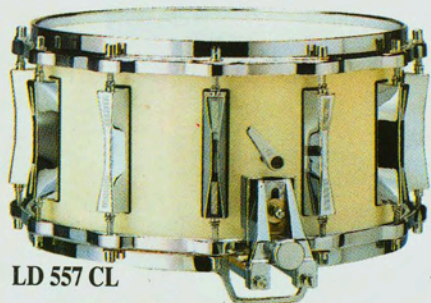

LD 557 CL



LD 557 OL



LD 547x MB



D 518x MR



D 508x



D 518x CB



D 516

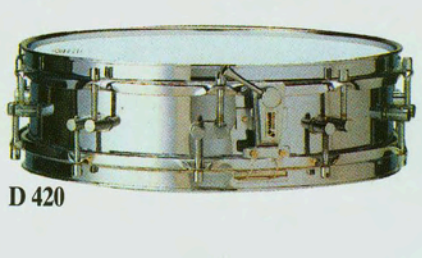

D 420

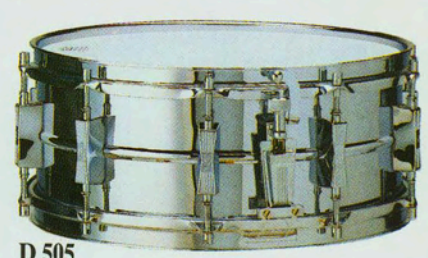

D 505

Features at a glance	HLD 588	HLD 580	HLD 582	HLD 581	LD 557	LD 547x	D 518x	D 508x	D 516	D 506	D 505	D 420
Parallel snare strainer	●	●	●	●	●							
„Throw-off II” strainer						●	●	●				
„Throw-off” strainer									●	●	●	
Standard snare strainer												●
Die-cast rims	●	●	●	●	●							
Ferro-manganese steel rims						●	●	●	●	●	●	●
24 tension screws	●	●	●	●	●							
20 tension screws						●	●	●	●	●	●	●
Snap-lock	●	●	●	●	●	●	●	●	●	●	●	
2 exchangeable snares	●	●	●	●	●							
Oscillographic tuning	●	●	●	●	●	●	●	●	●	●	●	●
External mufflers	●	●	●	●	●	●	●	●	●	●	●	●
Wood shell		●		●	●	●	●		●			
Ferro-manganese steel shell	●		●					●		●	●	●



# Signature Series

*The Signature Series comprises everything that is necessary for the perfection of sound and playing technique. This series is a breakthrough in the manufacturing of drums, of which we are very proud. As I feel personally responsible for this top-line, the drums are bearing my signature.*

*Signature drum sets are created by experts for professionals. For drummers who regard their drum set as a part of their message. For drummers who identify themselves with their instruments. A limited edition of distinction to which I proudly and confidently add my personal endorsement.*

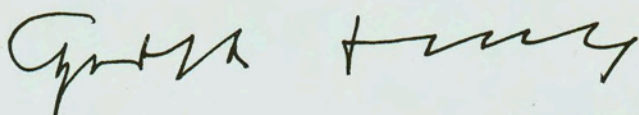

Horst Link



## Signature Shell

The deep, 12-ply shells are the core of the Signature sound. Due to this careful construction, every shell has a high flexional strength. Signature drums have newly designed extra deep shells, ensuring a perfectly balanced sound volume and projection.

## The Signature Sound

The construction of the Signature Series drum shells is different than that of conventional drums. The 12-ply shells are formed tension free from selected woods. Tension free means that the single plies form a solid sound unity, thus allowing the drum head an optimum of vibration. All Signature Series drums are available in two versions, giving the drummer a choice of two Signature Sounds: Heavy or Light. The Heavy shell made of beech with a thickness of 12 mms produces a mellow and dry sound. The Light shell, made of birch and only 7 mms thick, has a sound more responsive and direct. Both shells have extra deep dimensions, ensuring a perfectly balanced sound volume.

## Signature Finish

The inner and outer plies of a drum also have an influence on the sound. Because of their special structure and their outstanding acoustic properties, we chose African Bubinga and Indonesian Makassar Ebony. Firmly joined to the basic plies they contribute to the balanced sound of the Signature Series.

## Signature Warranty

Worldwide, the Signature Series is the first and only drum set with a 10-year limited warranty on materials and workmanship. This shows how much care is devoted to the construction of Sonor drums. From the stages of planning and testing, to production and service, one principle applies, quality.



# Signature Snare Drums

Cat. No.	Shell sizes
HLD 588	14" x 8"
HLD 580	14" x 8"
HLD 581	14" x 6½"
HLD 582	14" x 6½"



HLD 580, HLD 581 in 12-ply wood shells, Heavy or Light, in African Bubinga (RH) and Makassar Ebony (EB). HLD 588, HLD 582, made seamless from ferro-manganese steel. All have parallel snare strainers, exchangeable jazz (24) and rock (22) snares, die cast rims,

24 tensions screws with "Snap-lock" (pat.) system, oscillographically tuned batter and snare heads, adjustable external muffler.



HLD 580 EB



HLD 582

HLD 581 RH

# Signature Bass Drums

Cat. No.	Shell sizes
HLG 18	18" x 16"
HLG 20	20" x 17"
HLG 22	22" x 18"
HLG 24	24" x 18"



12-ply wood shell, available Heavy or Light version, finishes African Bubinga (RH) or Makassar Ebony (EB), twin-upright internal muffler system, shell mount fixed at four points, prism clamps for bass drum spurs, bass drum spurs which instantly convert from rubber tips to metal spikes (DGM), wooden hoops with Bubinga or Ebony finishes, "Snap-lock" (pat.) Pin Stripe batter head, transparent Ambassador front head.



HLG 22 RH

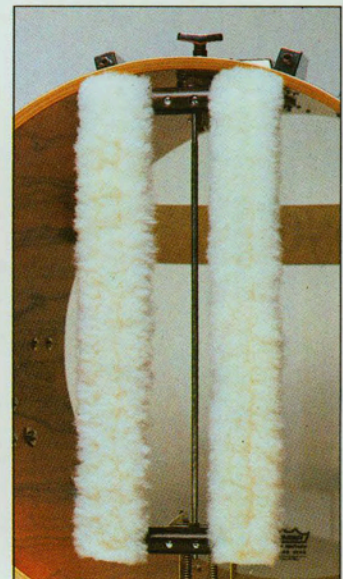
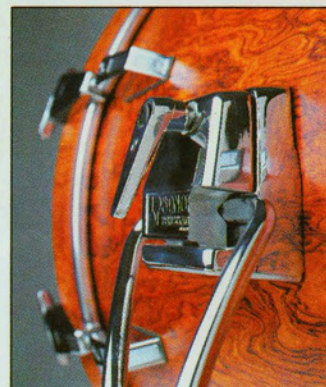





HLK 20212 RH







# Signature Tom Toms

Cat. No.	Shell sizes
HLT 8	8" x 8"
HLT 10	10" x 10"
HLT 12	12" x 12"
HLT 13	13" x 13"
HLT 14	14" x 14"
HLT 15	15" x 15"
HLT 16	16" x 16"



HLT 14 RH

HLT 14 EB



12-ply wood shell in Heavy or Light version. Finishes African Bubinga (RH) or Makassar Ebony (EB), shell mounts fixed at two points, seamless rims from ferro-manganese steel, tension screws with "Snap-lock" system (pat.), Pin Stripe batter head, transparent Ambassador bottom head, adjustable external muffler.

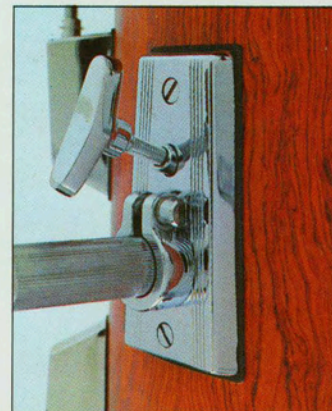

Wood is a natural product. Sonor drums with wood finishes always have a characteristic grain and a natural color. Therefore, two drums with wood finishes can never look exactly the same.

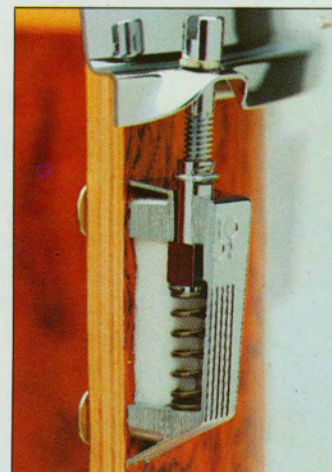

# Signature Floor Toms

Cat. No.	Shell sizes
HLFT 14	14" x 16"
HLFT 15	15" x 17"
HLFT 16	16" x 18"
HLFT 18	18" x 19"



12-ply wood shell in Heavy or Light version, finishes African Bubinga (RH) or Makassar Ebony (EB), prism clamp for floor tom legs, legs instantly convertible from rubber tips to metal spurs (DGM), seamless rims from ferro-manganese steel, tension screws with "Snap-lock" (pat.), Pin Stripe batter head, transparent Ambassador bottom head, adjustable external muffler. Also available, a set of extra long floor tom legs (Z 5080).

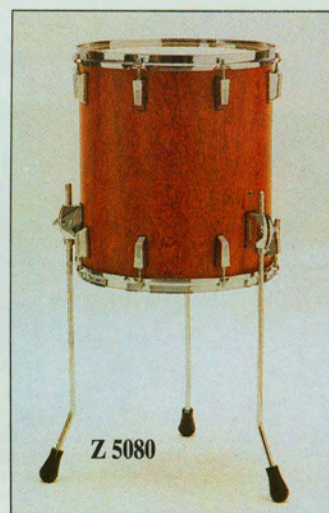

Z 5080



HLFT 16 EB

HLFT 16 RH

Signature drums available in the following finishes:

- RH** Bubinga
- EB** Ebony

























Suggested combinations for the Signature Series

Drum Set Code										
HLK 2085	HLD 581	HLG 18	HLT 10 HLT 12	HLFT 14	HLZ 5380	HLZ 5480	2x HLZ 5280	HLZ 5513b	HLZ 5580	
HLK 2005	HLD 582	HLG 20	HLT 12 HLT 13	HLFT 15	HLZ 5380	HLZ 5480	2x HLZ 5280	HLZ 5513b	HLZ 5580	
HLK 2028	HLD 580	HLG 22	HLT 10 HLT 12 HLT 13 HLT 14	HLFT 15 HLFT 16	HLZ 5380	HLZ 5480	4x HLZ 5280 Z 5273	HLZ 5513b	HLZ 5580	HLZ 5285
HLK 2046	HLD 588	HLG 24	HLT 13 HLT 14	HLFT 16 HLFT 18	HLZ 5380	HLZ 5480	3x HLZ 5280	HLZ 5513b	HLZ 5580	
Your personal choice										



# Sonorlite

*Sonorlite drums have been developed in response to drummers who are not only seeking an instrument with high quality sound, but also require a light, rigid shell design. In the construction of Sonorlite we have strived to meet the most demanding sound requirements. The same high manufacturing standards that we use in our full Sonor product range have*



*naturally been applied to Sonorlite. Nothing has been compromised. We have given painstaking attention to even the smallest detail.*

## The Sonorlite Shell

The Sonorlite drum shell is unique in several respects. It is made from Scandinavian Birch, which is also used in the production of aircraft. Its ratio of strength to weight is particularly favorable to percussion, so that a Sonorlite shell can be nearly 50% lighter than comparable shells. Snare drums and bass drum shells are 12-ply and measure 7 mms, while

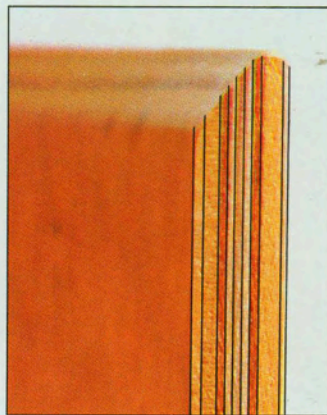

tom tom and floor tom shells are 9-ply and measure 6 mms.

## The Sonorlite Sound

Sonorlite drums produce a warm, rich and modern sound. The balanced sound volume is achieved by special shell sizes. Every Sonorlite shell is veneered inside with selected plies of high-quality Scandinavian Birch, giving the final touch to the sound.

## The Sonorlite Finish

Sonorlite drums are available in the following finishes: Scandinavian Birch (MB), Creme Lacquer (CL) and Onyx Lacquer (OL). Scandinavian Birch is a rarity from which we produce only a limited quantity of Sonorlite drums. Creme and Onyx are highly durable and resistance to light and fading.



# Sonorlite Snare Drums

Cat. No.	Shell sizes
LD 557*	14" x 7 1/4"
LD 547x°	14" x 7 1/4"
* with parallel snare action	
° with "throw-off II" snare action	



12-ply wood shell from Scandinavian Birch, LD 557 with parallel strainer, jazz snares (24 strands) and rock snares (22 strands) which can be exchanged, die-cast rims, 24 tension screws, LD 547x "Throw-off II", seamless rims from ferro-manganese steel, snares with 24 strands, 20 tension screws, "Snap lock" (pat.) oscillographically tuned batter and snare heads, adjustable external muffler.



LD 547x MB



LD 557 MB



LD 547x OL

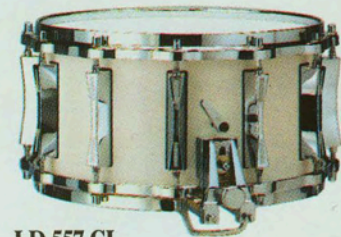

LD 557 CL

# Sonorlite Bass Drums

Cat. No.	Shell sizes
LG 18	18" x 15"
LG 20	20" x 16"
LG 22	22" x 17"
LG 24	24" x 17"



12-ply wood shell from Scandinavian Birch, shell mount for tom toms fixed at 4 points, prism clamp for spurs, spurs convertible from rubber tips to metal spikes, wood hoops, transparent Ambassador batter and front heads, felt strip muffler.



LG 22 MB



LG 20 CL





LK 1128 MB







# Sonorlite Tom Toms

Cat. No.	Shell sizes
LT 8	8" x 8"
LT 10	10" x 9"
LT 12	12" x 10"
LT 13	13" x 11"
LT 14	14" x 12"
LT 15	15" x 13"



LT 13 MB



9-ply wood shell from Scandinavian Birch, shell mount fixed at 2 points, seamless rims from ferro-manganese steel, tension screws with "Snap-lock" (pat.), transparent Ambassador batter and bottom heads, adjustable external muffler.



MB



OL



CL

Sonorlite drums are available in the following finishes:

- MB** Scandinavian birch
- OL** Onyx lacquer
- CL** Creme lacquer

# Sonorlite Floor Toms

Cat. No.	Shell sizes
LFT 14	14" x 15"
LFT 15	15" x 16"
LFT 16	16" x 17"
LFT 18	18" x 18"



LFT 16 MB

LFT 16 OL



9-ply wood shell from Scandinavian Birch, prism clamp for floor tom legs, legs with rubber tips, seamless rims from ferro-manganese steel, tension screws with "Snap-lock", transparent Ambassador batter and bottom heads, adjustable external muffler.

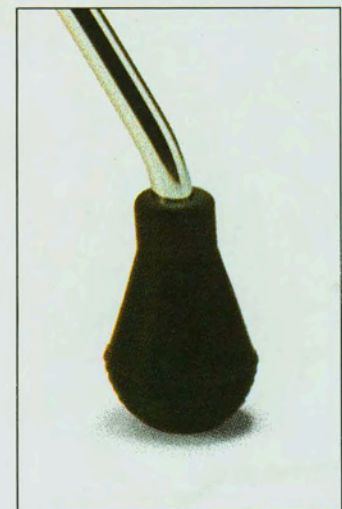

Wood is a natural product. Sonor drums with wood finishes always have a characteristic grain and a natural color. Therefore, two drums with wood finishes can never look exactly the same.













LK 1184 MB



LK 1105 CL













LK 1106 OL



LK 1127 MB

Suggested combinations for Sonorlite

Drum Set Code										
LK 1184	LD 547x	LG 18	LT 12	LFT 14	Z 5370	Z 5470	Z 5270	Z 5511b	Z 5570	
LK 1105	LD 557	LG 20	LT 12 LT 13	LFT 15	Z 5370	Z 5470	2x Z 5270	Z 5513b	Z 5570	
LK 1106	LD 557	LG 20	LT 12 LT 13 LT 14 LT 15		Z 5370	Z 5470	2x Z 5270	Z 5513b	Z 5570	Z 5275
LK 1127	LD 557	LG 22	LT 10 LT 12 LT 13 LT 14	LFT 16	Z 5370	Z 5470	4x Z 5270 Z 5273		Z 5570	2x Z 5275
Your personal choice										



# Phonic Phonic Plus

*Phonic and Phonic Plus drums are the foundation of the Sonor drum program. It is an extensive series with superior sound and great versatility. You may choose from the following pearl finishes: Gloss Black (CB), Gloss White (CW), Candy Apple Red (KR), and the wood finish Red Mahogany (MR). Phonic drum shells are made in the proven standard sizes. The extended shells of the Phonic Plus series produce additional volume. Drums from both series are interchangeable and can be combined in one drum set.*

## The Phonic and Phonic Plus Sound

All Phonic and Phonic Plus drums have a 9-ply shell made from high-quality beech. They are renowned for their full sound and high projection. Within the Sonor program, Phonic and Phonic Plus drums offer the largest choice of shell sizes.

With Sonor's wide range of mounting systems you have the opportunity to compose a set to suit your specific needs and sound requirements.



*Phonic Plus Drum Set XK 1228  
in Gloss White (CW)*

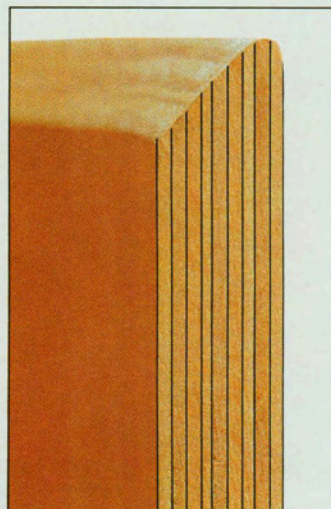

*Cutaway of a 9-ply Phonic  
Phonic Plus drum shell. The  
bearing edge of the shell,  
bevelled to 45°, ensures a perfect  
resting of the head and produces  
an effective sound projection.*



# Phonic Phonic Plus Snare Drums

Cat. No.	Shell sizes
D 420	14" x 3½"
D 505	14" x 5¾"
D 506	14" x 6½"
D 516	14" x 6½"
D 508x	14" x 8"
D 518x	14" x 8"



D 508x



Phonic and Phonic Plus Snare Drums are available with wood or metal shells, wood shells made from 9-ply beech-wood, metal shells from seamless ferro-manganese steel, finishes of the wood shells in Red Mahogany (MR), Gloss Black (CB), Gloss White (CW), Candy Apple Red (KR), D 516 veneered inside and outside with Genuine Rosewood. D 420 with standard snare strainer, D 505, D 506, D 516 with "Throw-off" snare strainer and D 508x and D 518x with "Throw-off II" snare strainer, snares with 24 strands, seamless rims from ferro-manganese steel, tension screws with "Snap-lock" (pat.), except D 420, oscillographically tuned batter and snare heads, adjustable external muffler.

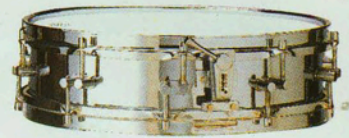

D 420

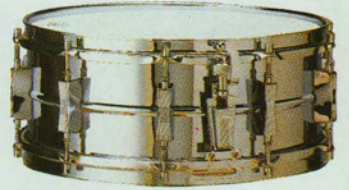

D 505



D 516



D 518x MR

# Phonic Phonic Plus Bass Drums

Cat. No.	Shell sizes
G 318	18" x 14"
G 320	20" x 14"
G 322	22" x 14"
G 324	24" x 14"
G 20	20" x 17"
G 22	22" x 18"
G 24	24" x 18"

G 22 CB



9-ply beech shell, shell mount for tom toms fixed at 4 points, prism clamp for bass drum spurs, spurs convertible from rubber tips to metal spikes, metal rims. Phonic with white Ambassador batter and front heads, Phonic Plus with Pin Stripe batter head and transparent Ambassador front head, felt strip muffler.

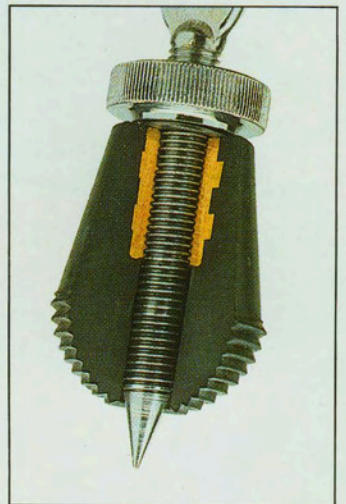

G 322 CW

Sonor Phonic and Phonic Plus drums are available in the following finishes:

- CB** Gloss Black
- CW** Gloss White
- KR** Candy Apple Red
- MR** Red Mahogany





XK 1229 MR







# Phonic Phonic Plus Tom Toms

Cat. No.	Shell sizes
T 780	8" x 8"
T 720	10" x 8"
T 722	12" x 8"
T 723	13" x 9"
T 724	14" x 10"
T 725	15" x 12"
T 8	8" x 8"
T 10	10" x 10"
T 12	12" x 12"
T 13	13" x 13"
T 14	14" x 14"
T 15	15" x 15"



9-ply beech-wood shell, shell mount fixed at 2 points, seamless rims from ferro-manganese steel, tension screws with "Snap-lock" (pat.). Phonic with white Ambassador batter and bottom heads, Phonic Plus with Pin Stripe batter head and transparent Ambassador bottom head, adjustable external muffler.



T 14 KR

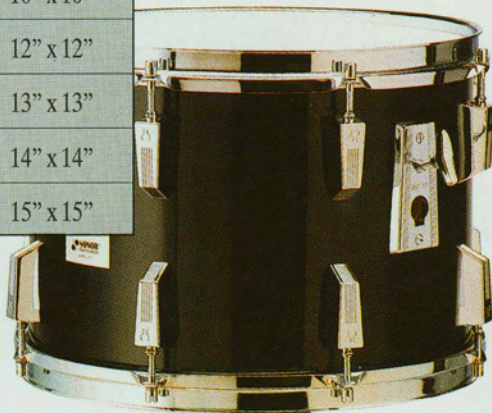

T 724 CB



CB



CW



KR



MR

# Phonic Phonic Plus Floor Toms

Cat. No.	Shell sizes
T 734	14" x 14"
T 736	16" x 16"
T 738	18" x 16"
FT 15	15" x 17"
FT 16	16" x 18"
FT 18	18" x 19"



9-ply beech-wood shell, prism clamp for floor tom legs, legs with solid rubber feet, seamless rims from ferro-manganese steel, tension screws with "Snap-lock" (pat.). Phonic with white Ambassador batter and bottom head, Phonic Plus with Pin Stripe batter head and transparent Ambassador bottom head, adjustable external muffler.



FT 16 MR



T 736 CW







  
**SONOR®**  
PERCUSSION  
No. \_\_\_\_\_  
GENUINE MAHOGANY VENEER  
MADE IN GERMANY

  
LUDWIG  
MADE IN GERMANY



















Suggested combinations for the Phonic and Phonic Plus Drum Sets

Drum Set Code										
XK 984	D 505	G 318	T 722	T 734	Z 5370	Z 5470	Z 5270	Z 5511b	Z 5570	
XK 925	D 506	G 322	T 723 T 724	T 736	Z 5370	Z 5470	2x Z 5270	Z 5513b	Z 5570	
XK 1225	D 518x	G 22	T 13 T 14	FT 16	Z 5370	Z 5470	2x Z 5270	Z 5513b	Z 5570	
XK 1246	D 518x	G 24	T 14 T 15	FT 16 FT 18	Z 5370	Z 5470	3x Z 5270	Z 5513b	Z 5570	
Your personal choice										



# Percussion

Sonor conga drums and bongos are aimed at the demanding percussionist. Each instrument is individually handcrafted from selected wood by a skilled craftsman. Sizes and design meet professional standards.

**L 810** Tumbadora  
12½" (32 cms) head dia.,  
28¾" (73 cms) height

**L 811** Conga  
11¾" (30 cms) head dia.,  
28¾" (73 cms) height

**L 812** Quinto  
11" (28 cms) head dia.,  
28¾" (73 cms) height

**L 851** Bongos, with wood shells, central tensioning  
6" x 6¾" (15 x 17 cms),  
8" x 6¾" (20 x 17 cms)

**L 852** Bongos, with wood shells, strong outside tensioning  
7¼" x 6¼" (18 x 16 cms),  
8½" x 6¼" (22 x 16 cms)



*The connecting part of all bongos has two holes for the stand and for a cow bell holder*



**Z 7210** low stand for L 810  
**Z 7211** low stand for L 811  
**Z 7212** low stand for L 812  
**Z 8210** high stand for L 810  
**Z 8211** high stand for L 811  
**Z 8212** high stand for L 812

**Z 7204** stand for bongos, with double braced legs and rubber tips



L 811 Z 7211

L 810 Z 7210

L 812 Z 7212



# Hardware

**Signature Series Hardware** with instantly convertible "flip-over" rubber tips to metal spikes (DGM), pre-set "fix-clamps" for easy set-up, large lever grips for swift tightening, double braced legs with solid stainless steel riveting.

**HLZ 5285** double tom stand

**HLZ 5580** snare drum stand with quick-release on-and-off lever

**Phonic Plus Hardware** with double braced legs for support, legs equipped with solid rubber tips, steel ring clamps for secure height adjustments.

## Drummer's thrones

**Z 5803** drummer's throne, upholstered, adjustable height, foldable legs

**Z 5810** drummer's throne, upholstered, threaded height adjustment for quick and accurate set-up

**Z 5812** most comfortable drummer's throne with saddle and back rest, ideal for long sessions, quick and accurate height adjustment with heavy duty base

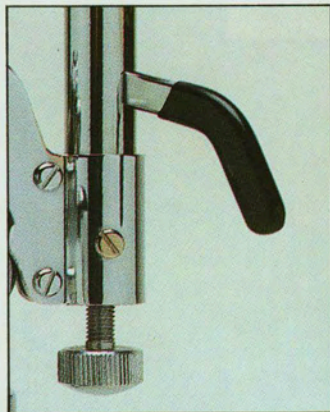

**Z 5275** double tom stand

**Z 5570** snare drum stand with quick-release on-and-off lever

**Z 5579** extension tube for Z 5570 and HLZ 5580

**Z 7204** bongo stand



Z 5812

Z 5810

Z 5803

Z 7204

Z 5570





Z 5579

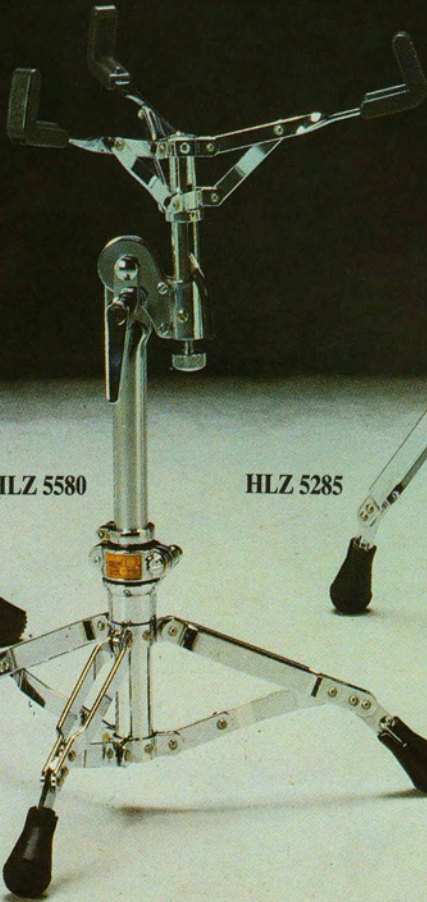

HLZ 5580

HLZ 5285



Z 5275





Z 5272

Z 5270

HLZ 5280

Z 5278



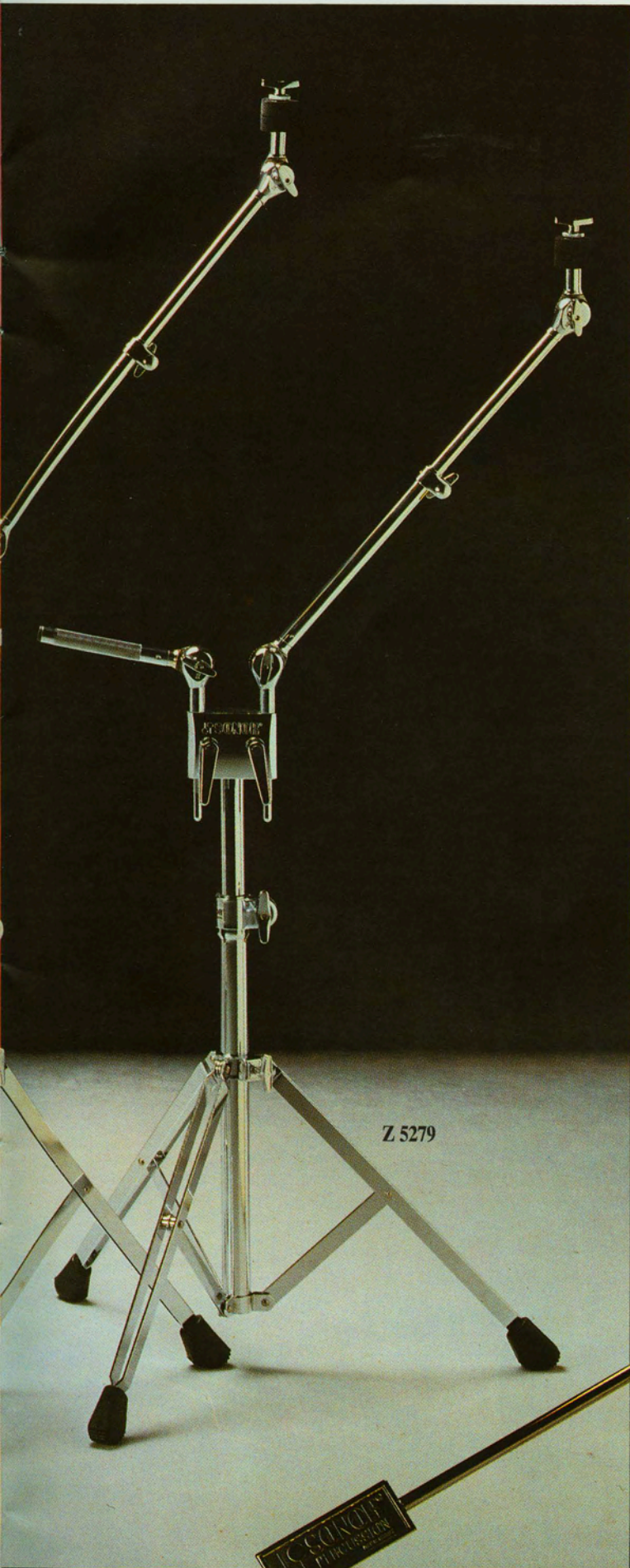

**Signature Series Cymbal Stand** with instantly convertible "flip-over" rubber tips to metal spurs (DGM), pre-set "fix-clamps", large lever grips for easy tightening, double braced legs.

**HLZ 5280** cymbal stand

**Phonic Plus Cymbal Stand** with double braced legs, solid rubber feet, steel ring clamps for secure height adjustments

**Z 5272** light weight single braced cymbal stand

**Z 5270** heavy duty double braced cymbal stand

**Z 5278** double cymbal stand

**Z 5279** double stand for cymbal/tom tom

**Z 5273** cymbal boom arm without tilter

**Z 5277** cymbal extension arm without tilter

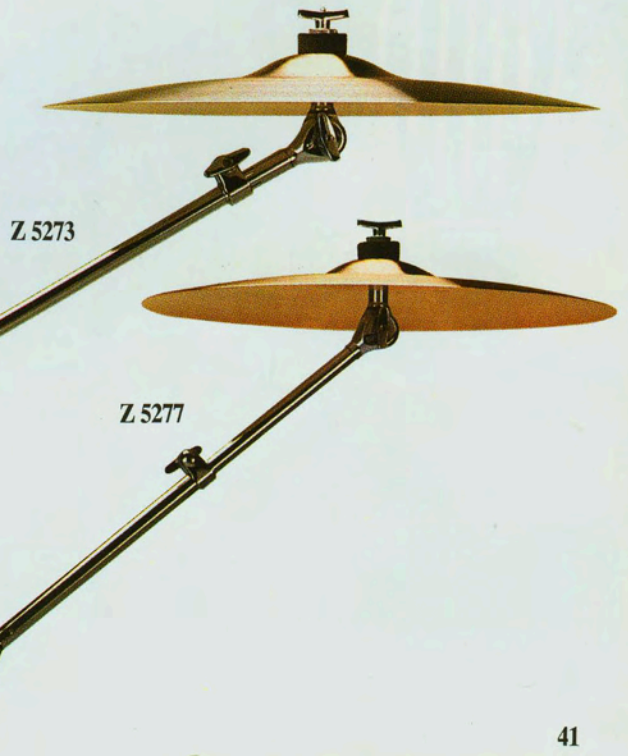



# Bass Drum Pedals

## HLZ 5380

Signature Series bass drum pedal with rugged double steel chain, foot board holder with cast-in brass bushing (pat. pend.), adjustable conical felt beater with tempered steel shaft, two roller bearings for smooth and fast action, comes complete with three springs – soft, medium and hard, foot board with metal and vulcanized rubber inserts (DGM), height adjustable base, king-size clamp screw to allow swift attaching of the pedal to the bass drum rim.

## Illustrations:

- ① rugged double steel chain and footboard holder with cast-in brass bushing (pat. pend.)
- ② clamp screw and clamp lever to allow swift locking to the bass drum rim
- ③ Four types of beaters:
  - Sch 20 felt beater
  - Sch 21 wool and leather beater
  - Sch 24 wood beater
  - Sch 26 quick beater

- ① conical felt beater
- ② tempered steel shaft
- ③ wing nut for simple adjustment of the spring tension
- ④ knurled nut for setting the spring tension
- ⑤ infinitely adjustable tension spring
- ⑥ rugged double steel chain
- ⑦ clamp screw for swift attachment to the bass drum rim
- ⑧ two roller bearings for smooth and fast action
- ⑨ locking screw for adjustment of spring holder position
- ⑩ foot board with metal and vulcanized rubber inserts: prevents slipping but still allows liberty of movement
- ⑪ toe stop
- ⑫ slotted screws for height adjustment of base and foot board
- ⑬ clamp lever for swift attachment to the bass drum rim
- ⑭ spring loaded spurs to ensure a secure hold to the floor
- ⑮ fixed struts prevent an upward folding of the foot plate during play

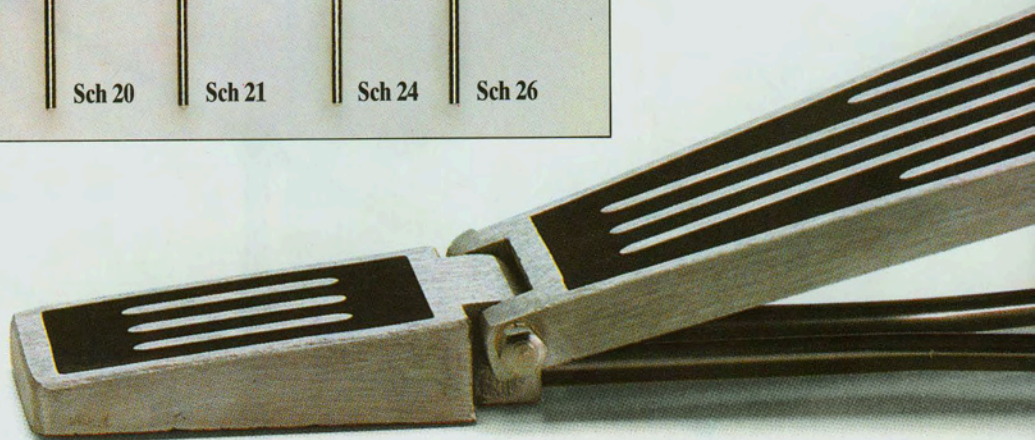
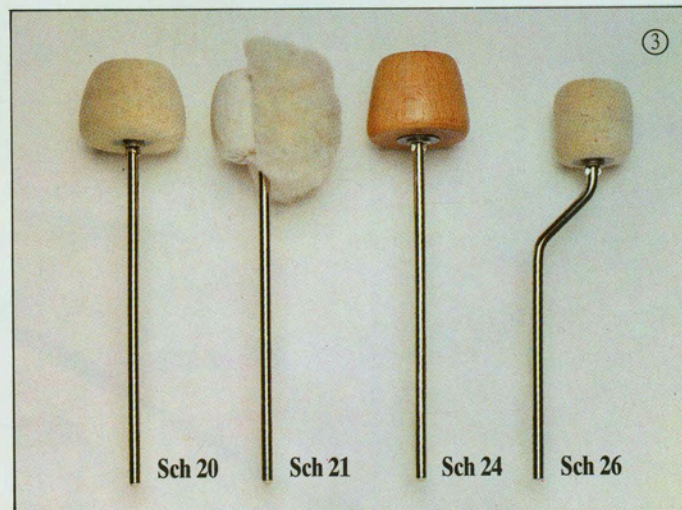
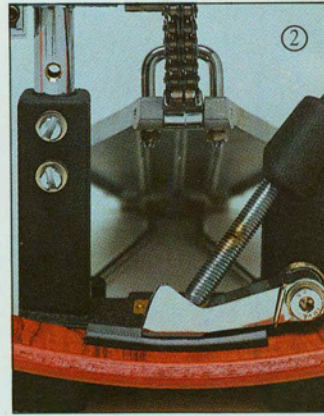
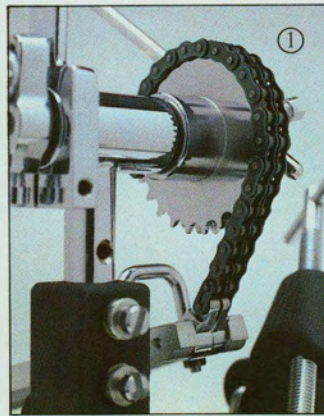
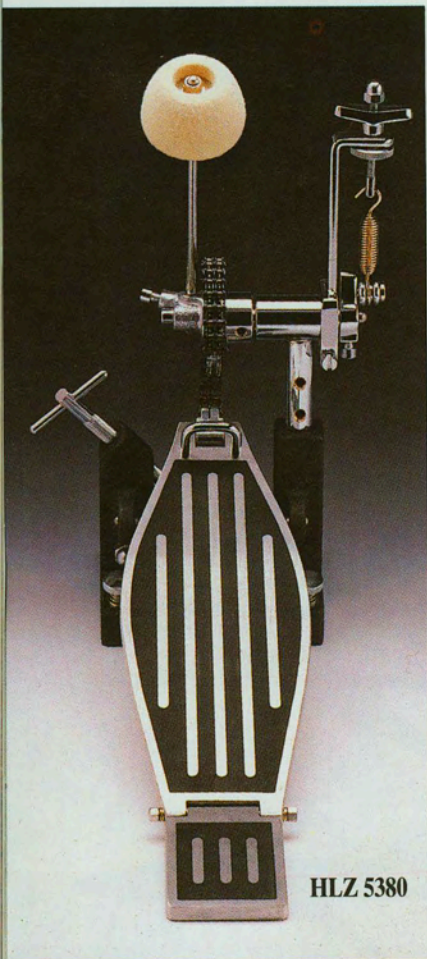



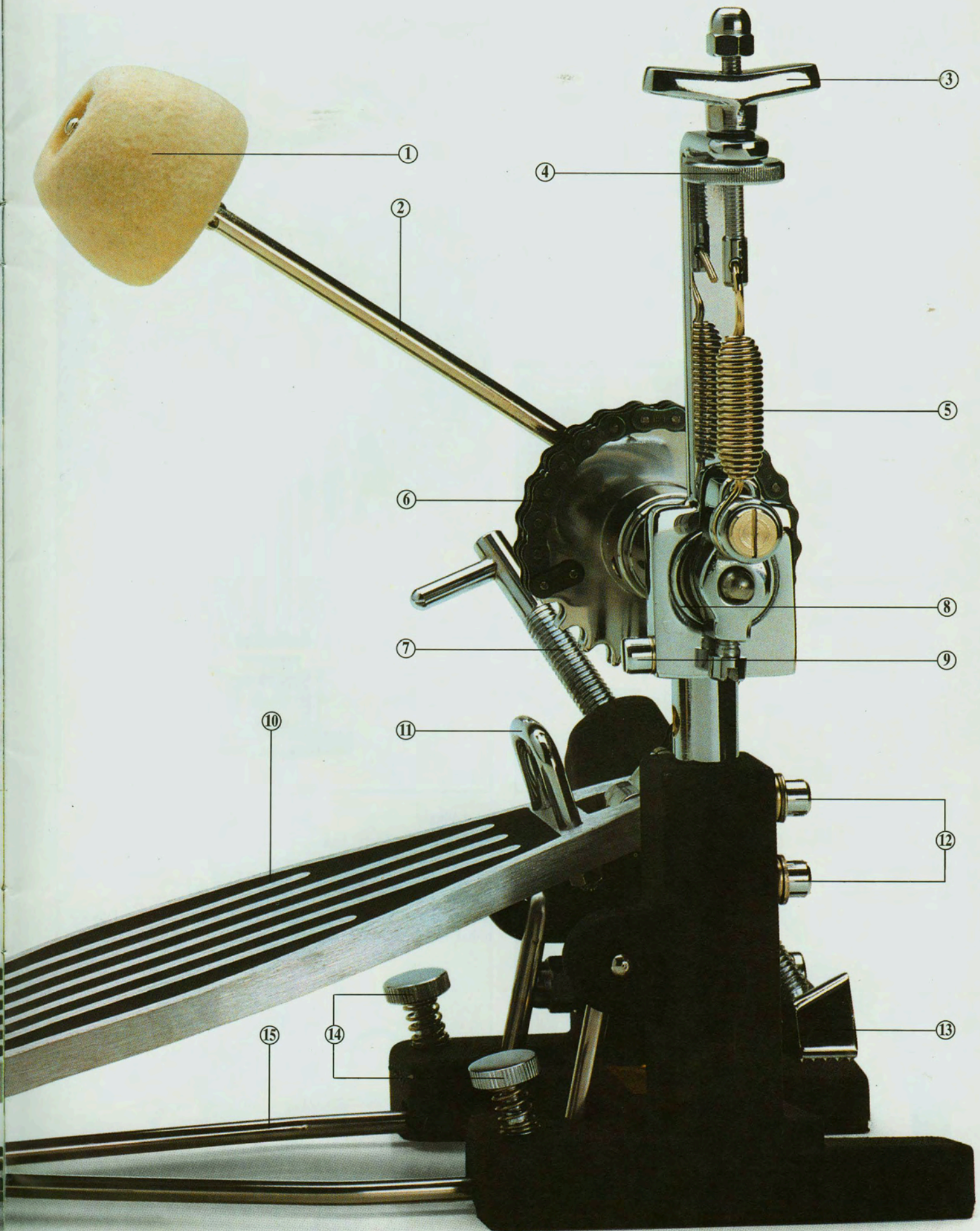



# Bass Drum Pedals

## Z 5370

Phonic Plus bass drum pedal with two upright pillars, two roller bearings, conical felt beater with adjustable tempered steel shaft, adjustable tension spring, complete with three springs – soft, medium and hard, adjustable height foot plate with toe stop, clamp lever that allows easy attachment to the bass drum rim.

## Z 5371

Bass drum pedal identical to model Z 5370, except for a smaller metal foot board.

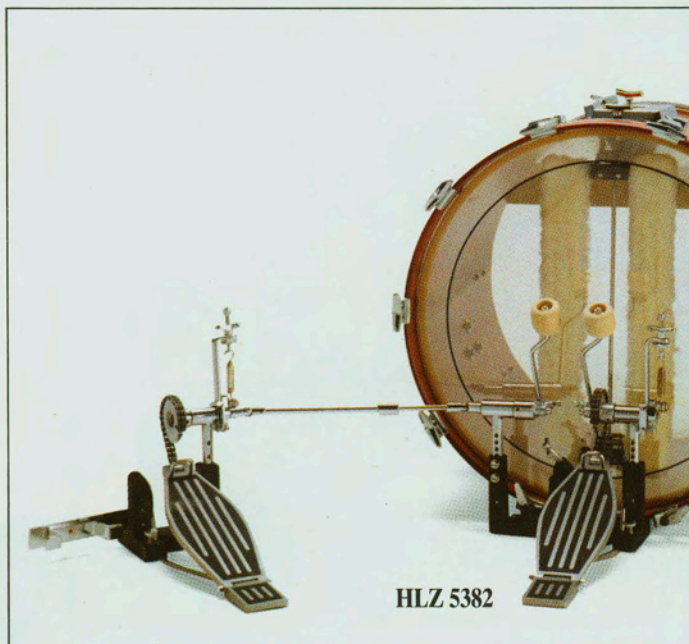
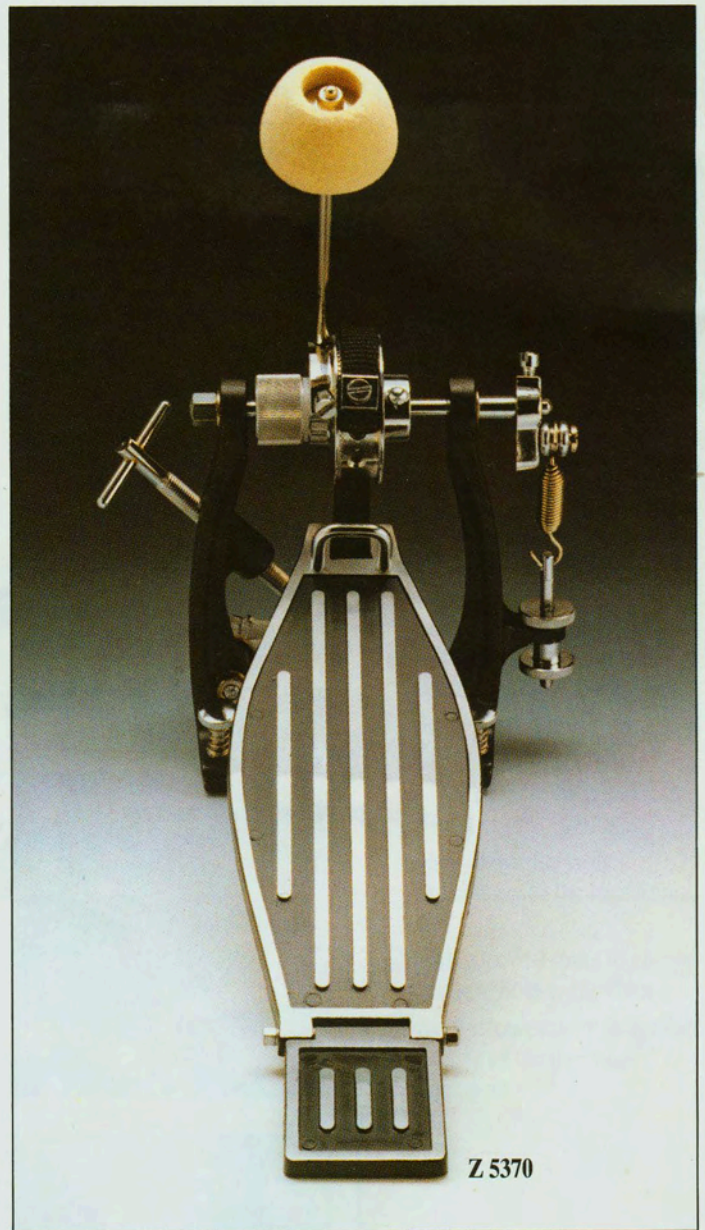
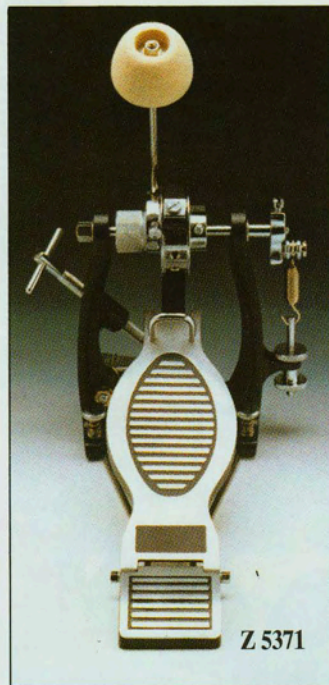

## HLZ 5382

Signature Series double bass drum pedal, identical to model HLZ 5380, but gives double bass drum effect, adjustable pedal spacing, connection piece for hi-hat, two special felt beaters.





# Hi-Hats

## HLZ 5480

Signature Series hi-hat with adjustable spring tension, clutch with roller locking device (pat. pend.) to tightly secure top cymbal, bottom cymbal seat with angle adjustment screw, "flip-over" rubber tips to metal spurs for secure hold on every kind of floor (DGM), rugged steel pull chain (DGM), foot plate integrating vulcanized rubber with metal inserts (DGM), pre-set "fix-clamps".

Sonor developed the clutch with a roller locking device (pat. pend.) to ensure an absolutely secure and reliable adjustment of the top cymbal. Slight finger tightening of the regulating screw is all that is necessary to fix the locking device. A clamping plate presses the rollers against the centre pull rod, eliminating any chance of slippage. A pressure spring brings the rollers back to their original position when the screw is released.

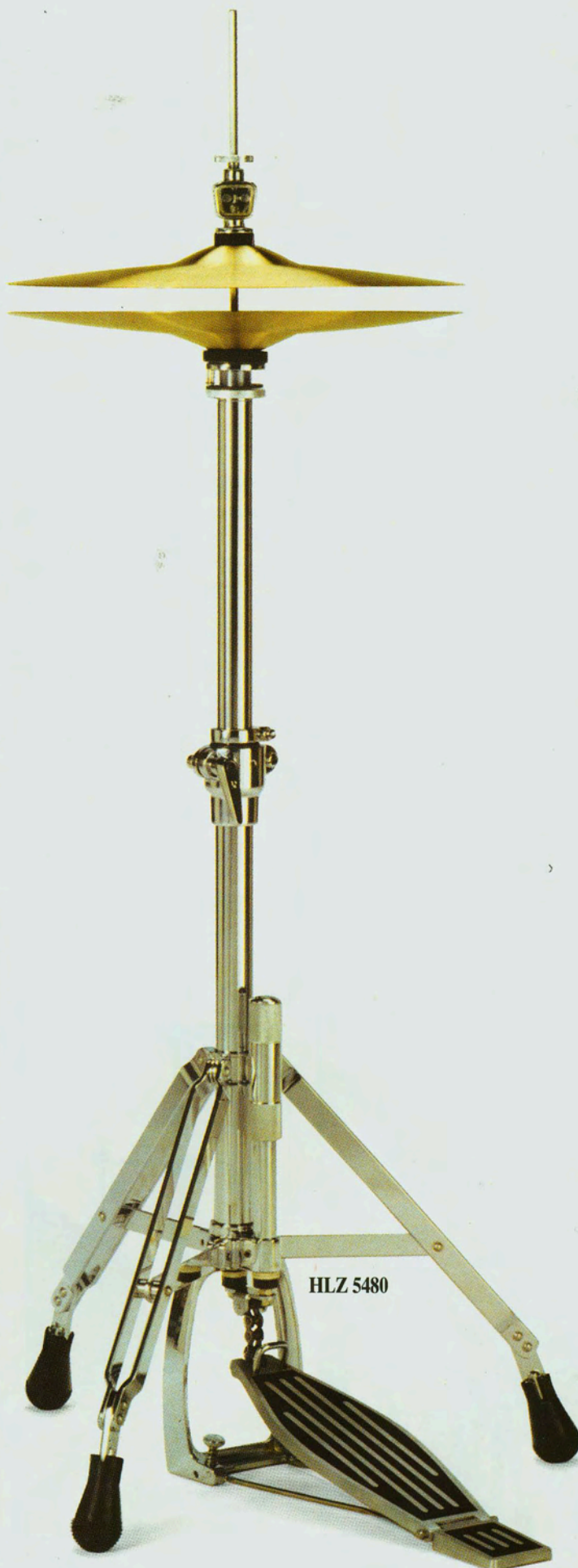
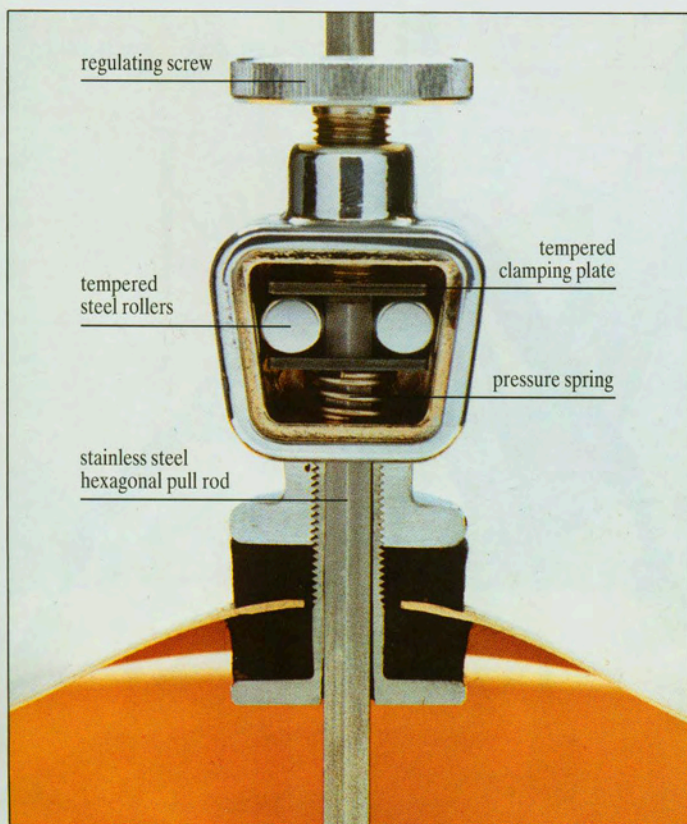



# Hi-Hats

## Z 5474

Phonic Plus hi-hat with solid riveted double braced legs, externally adjustable tension spring, stainless steel hexagonal pull rod prevents loosening of the clutch, pressure cast metal foot plate with toe stop, felt muffled pull strap, convertible rubber tips to metal spikes, bottom cymbal seat adjusts to allow 7 different angles (pat. pend.)

## Z 5470

Phonic Plus hi-hat, identical to Z 5474, except that the tension is adjustable by changing the inner springs, comes with two extra springs of different tension

## HLZ 5489

Signature Series legless hi-hat includes clamp (Z 5515) for attaching hi-hat to a double bass drum set

## Z 5515

clamp only

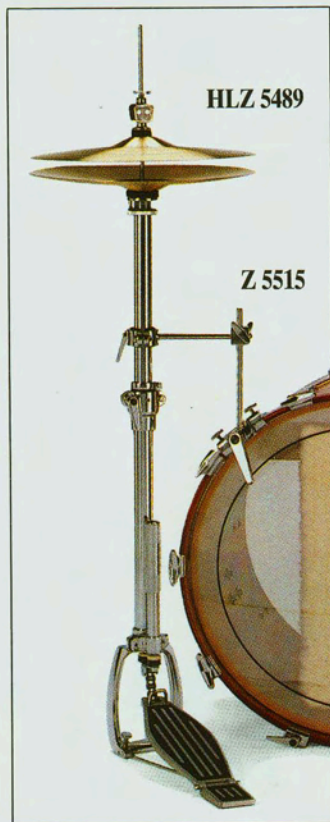
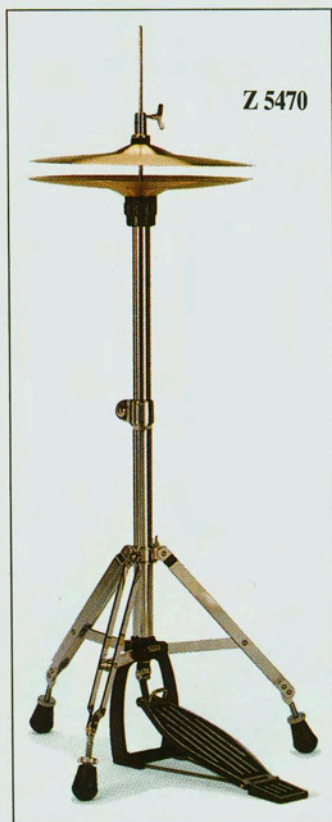
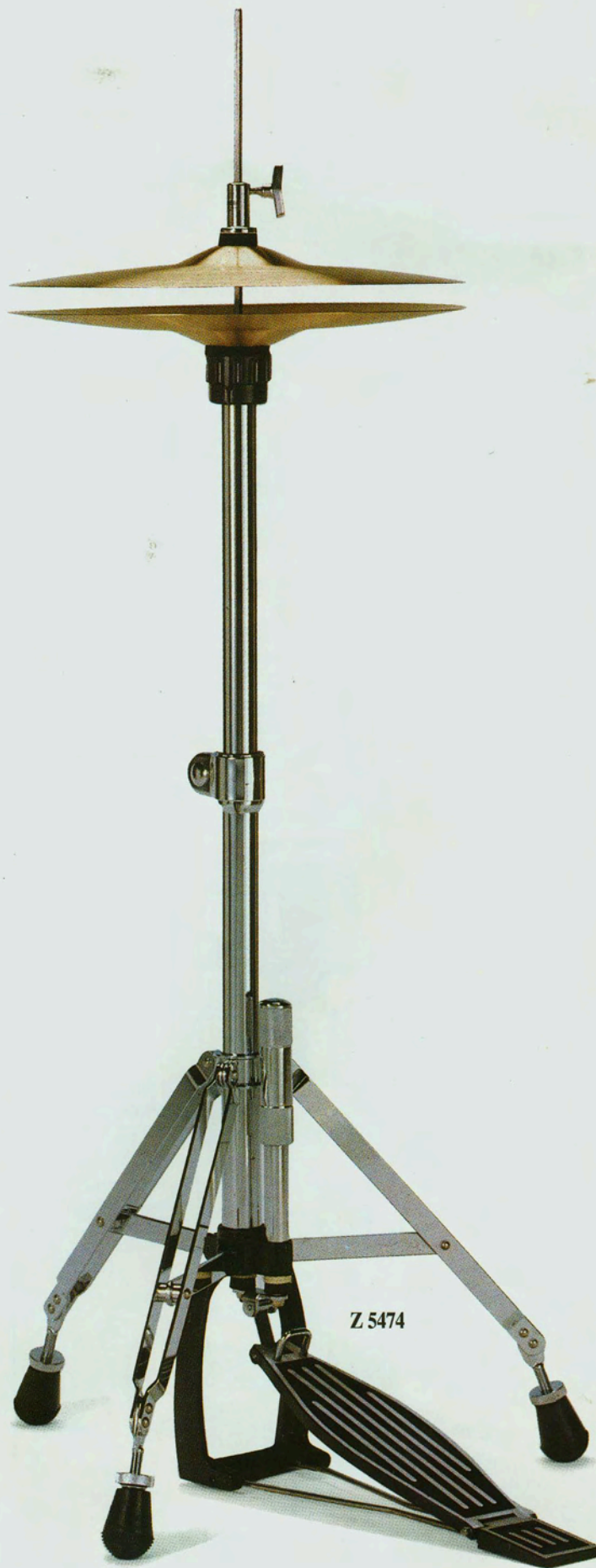



# The Sonor Holder System

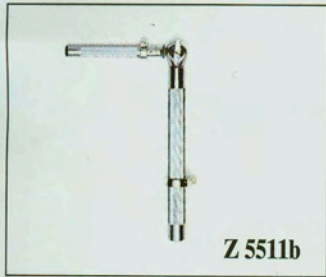

Z 5511b

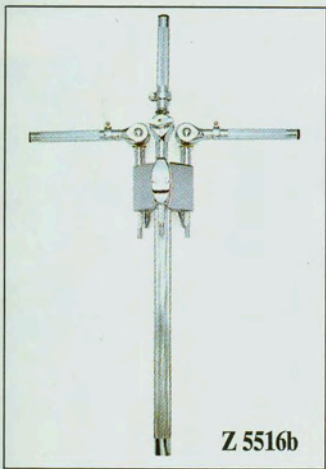

Z 5516b

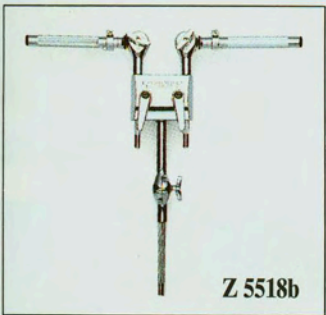

Z 5518b

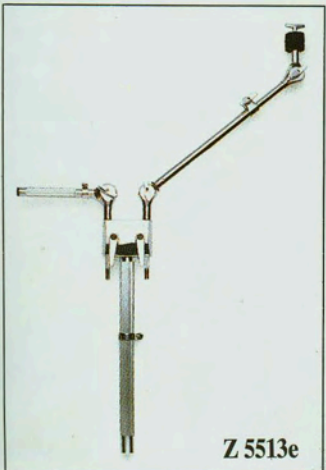

Z 5513e

The Sonor holder system allows a large number of secure set-ups to fit any drummer's needs. The double tom holder (Z 5513b) is the nucleus of this system, with an attachment for prism clamp Z 5507c for expansion.

- Z 5511b Single Tom Holder
- Z 5513b Double Tom Holder
- Z 5516b Triple Tom Holder
- Z 5518b Additional Double Tom Holder
- Z 5513e Double Holder for Cymbal/Tom Tom
- Z 5508c Tom Tom Arm

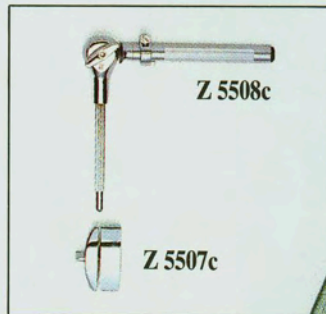

Z 5508c

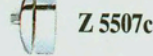

Z 5507c

- Z 5507c Prism Clamp
- Z 5274 Cymbal Arm with tilter

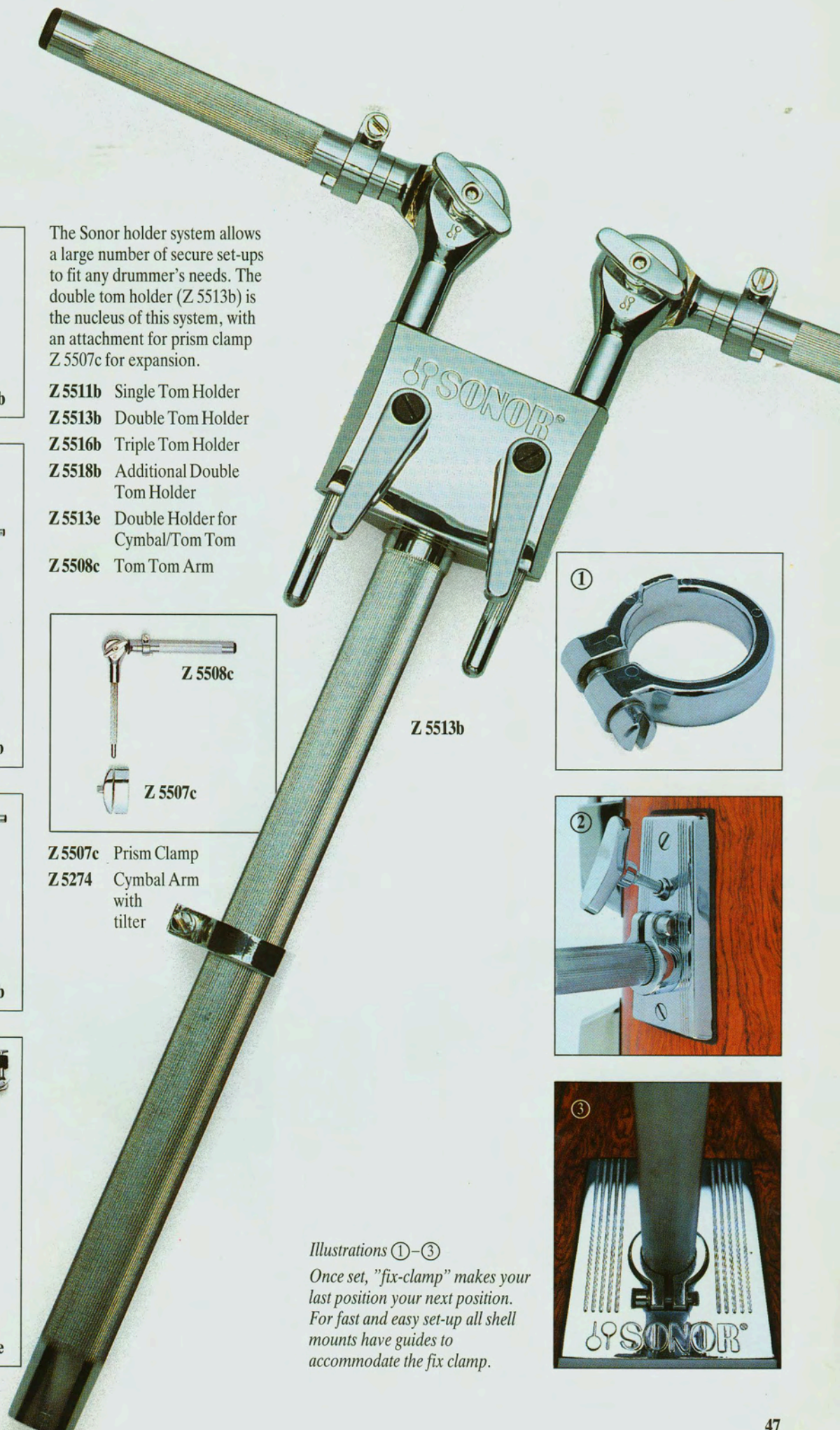

Z 5513b

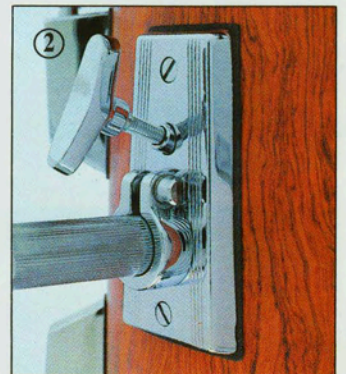

Illustrations ①-③

Once set, "fix-clamp" makes your last position your next position. For fast and easy set-up all shell mounts have guides to accommodate the fix clamp.



# The Sonor Holder System

- ①  
Single Tom Holder  
**Z 5511b**
- ②  
Double Tom Holder  
**Z 5513b**
- ③  
Double Holder for Cymbal/  
Tom Tom  
**Z 5513e**
- ④  
Triple Tom Holder  
**Z 5516b**
- ⑤  
Triple Holder for two Tom Toms  
and one Cymbal  
**Z 5513b + Z 5507c + Z 5274**
- ⑥  
Triple Holder for one Tom Tom  
and two Cymbals  
**Z 5513e + Z 5507c + Z 5274  
+ Z 5277**
- ⑦  
Quadruple Tom Holder  
**Z 5513b + Z 5507c + Z 5518b**
- ⑧  
Quadruple Holder for three  
Tom Toms and one Cymbal  
**Z 5513b + Z 5507c + Z 5518b  
+ Z 5274**
- ⑨  
Quadruple Holder for two  
Tom Toms and two Cymbals  
**Z 5513b + Z 5507c + Z 5518b  
+ 2 x Z 5274**
- ⑩  
Quintuple Holder for four  
Tom Toms and one Cymbal  
**Z 5513b + 2 x Z 5507c + Z 5518b  
+ Z 5274**
- ⑪  
Sixfold Holder  
**Z 5513b + 2 x Z 5507c  
+ 2 x Z 5518b**
- ⑫  
Sixfold Holder for four  
Tom Toms and two Cymbals  
**Z 5513b + 2 x Z 5507c  
+ 2 x Z 5518b + 2 x Z 5274**

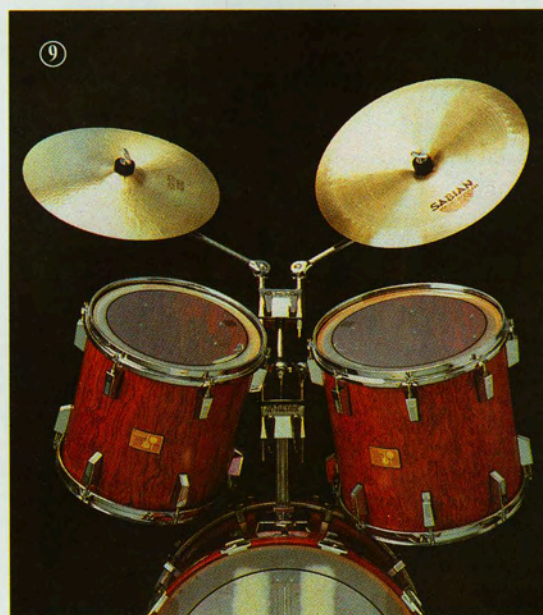







# Vario Clamp System

This system allows a great number of set-ups that were never possible before. Its prism mechanism clamps tightly and guarantees secure adjustment. Tubes and rods measuring between 6 and 32 mms can be assembled with the Vario Clamp. A ratchet link allows not only height and side adjustments, but also a wide variety of angle positions. For fast assembly the Vario Clamp has a folding mechanism which opens the prism.

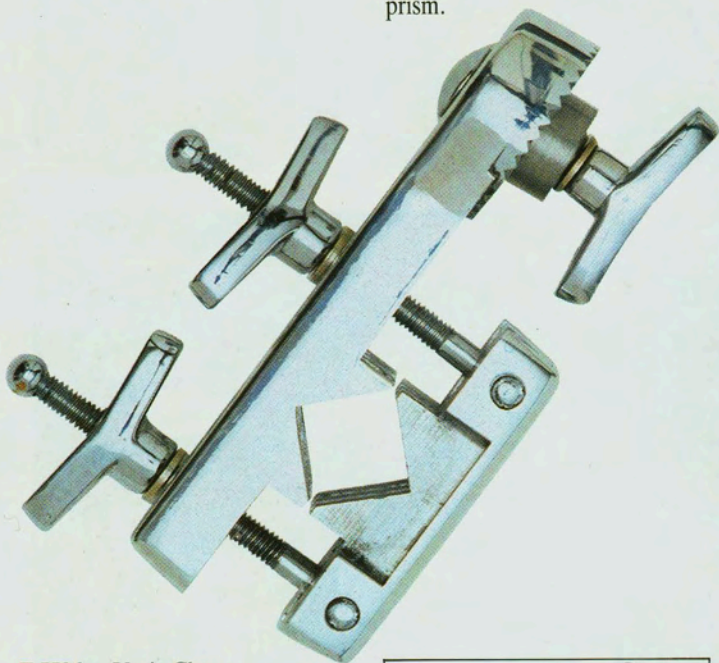

Z 5526a Vario Clamp  
Z 5526b Vario Clamp

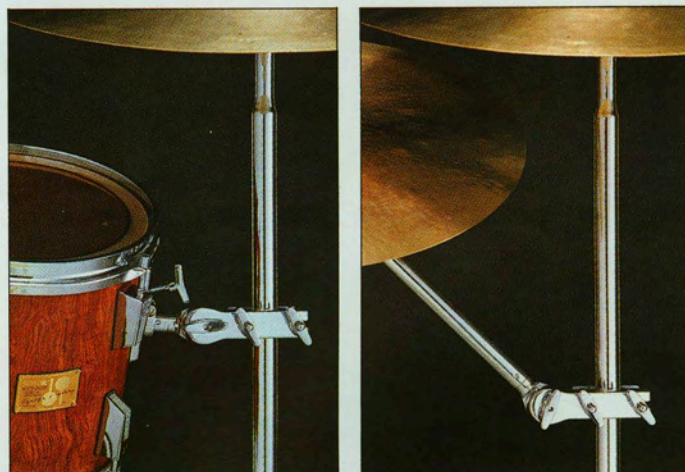
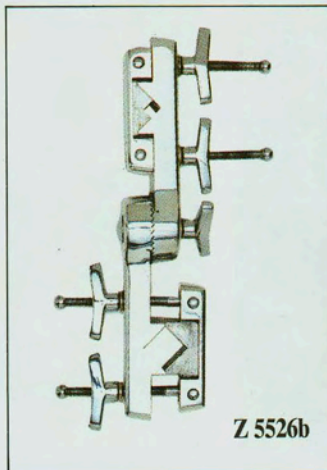
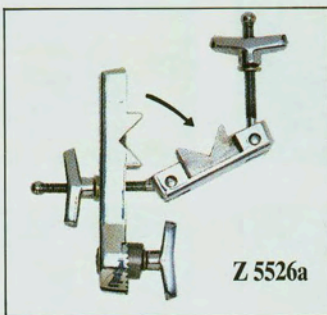



# Accessories

**Z9101** T-Shirt  
100% cotton, bordeaux with white imprint,  
Sizes: S, M, L, XL

**Z9100** Sweat Shirt  
100% cotton, bordeaux with white imprint,  
Sizes: S, M, L, XL

**Z9104** Tour Jacket  
100% cotton, black with white imprint,  
Sizes: S, M, L, XL

**Z9103** towel  
100% cotton, pink, with bordeaux imprint

**Z9300** practice pad

**Z5111** external muffler, small

**Z5112** external muffler, large

**Z5070** spin key

**Z5071** drum key, long

**Z5072** drum key, short

**Z9210** Drum Care Kit  
consisting of wood polish, chrome polish, light machine oil, lube and cloth, complete in a black vinyl bag

**Z9301** Remo Muffl's, with foam-o-ring

**Z9302** Remo Muffl's, with foam disc

Muffl's consist of a plastic tray, a ring control, an o-ring and one or two full foam discs. Muffl's offer four different levels of sound control:

1. Use plastic tray only under the topside drum head. Cuts out 80% of the overring without altering the basic drum sound.
2. Add the ring control's foam o-ring for complete elimination of overring.
3. Use the plastic tray with one full foam disc under the topside batter head. Produces a much dryer sound.
4. Add the sound control's second foam disc resting on the bottom head to cut out virtually all of the head's resonance. Changes any tom into a silent practice tom.



Z 9101

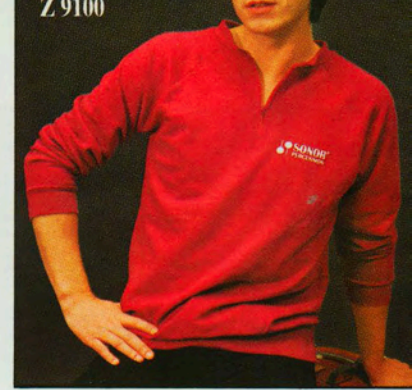

Z 9100



Z 9104



Z 9100



Z 9103



Z 9300



Z 5111

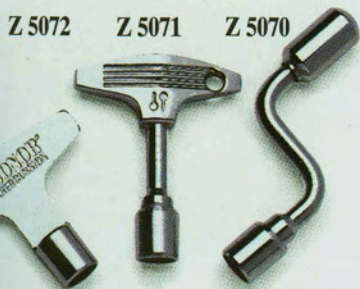

Z 5072

Z 5071

Z 5070



Z 9210

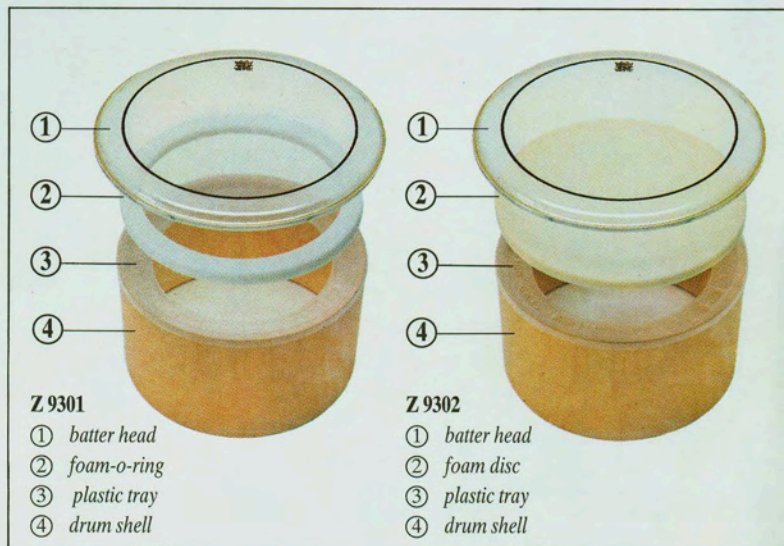

Z 9301

- ① batter head
- ② foam-o-ring
- ③ plastic tray
- ④ drum shell

Z 9302

- ① batter head
- ② foam disc
- ③ plastic tray
- ④ drum shell



# Sabian Cymbals

Sabian is a new company born from years of experience. Exciting new sounds and startling good looks are the Sabian hallmark. Created by combining the most advanced methods of production with the centuries old tradition of craftsmanship still practiced by their cymbal makers, some of

whom have brought experience from Istanbul to the Sabian plant in Canada. Each cymbal is cast from the best raw materials available, to which Sabian adds their own unique processes and a level of skill that's rare in the cymbal industry today.

	Cymbal dia.	8"	10"	12"	13"	14"	15"	16"	17"	18"	19"	20"	21"	22"	24"
Sabian AA	Splash	20805	21005	21205											
	Extra Thin Crash				21336	21436	21536	21636	21736	21836					
	Thin Crash				21306	21406	21506	21606	21706	21806					
	Medium Thin Crash							21607	21707	21807	21907	22007			
	Medium Crash							21608	21708	21808	21908	22008			
	Heavy (Rock) Crash							21609	21709	21809	21909	22009			
	Crash Ride							21611	21711	21811	21911	22011	22111	22211	
	Thin Ride							21610	21710	21810	21910	22010			
	Medium Ride							21612	21712	21812	21912	22012	22112	22212	22412
	Medium Heavy Ride							21613	21713	21813	21913	22013	22113	22213	22413
	Heavy (Rock) Ride											22014	22114	22214	22414
	Dry Ride												22135	22235	
	Flat Bell									21817		22017		22217	
	Mini Bell									21818		22018		22218	
	Chinese Flat									21815		22015		22215	
Chinese Regular									21816		22016		22216		
Sabian HH	Splash	10805	11005												
	Thin Crash					11406	11506	11606	11706	11806	11906	12006			
	Medium Thin Crash					11407	11507	11607	11707	11807	11907	12007			
	Crash Ride									11811	11911	12011	12111		
	Medium Ride									11812	11912	12012	12112	12212	12412
	Heavy Ride										11914	12014	12114	12214	12414
	Chinese Regular									11816		12016		12216	
Sabian B 20	Crash							31606							
	Crash Ride									31811					
	Ride											32012			
Sabian AA Hi Hats	Light Hats				21301	21401	21501								
	Regular Hi-Hats				21302	21402	21502	21602							
	Rock Hats					21403	21503								
	Flat Hats				21304	21404	21504								
Sabian HH	Hi-Hat			11302	11402	11502	11602								
Sabian B 20	Hi-Hat				31402										
Sabian AA Classical	French									21819		22019		22219	22419
	Viennese							21620		21820		22020		22220	
	Concert Band				21421	21521	21621		21821		22021		22221		
	Marching				21422	21522	21622		21822		22022		22222	22422	
Sabian HH Classical	Viennese						11620	11720	11820	11920	12020	12120	12220		
	Germanic						11624	11724	11824	11924	12024	12124	12224		

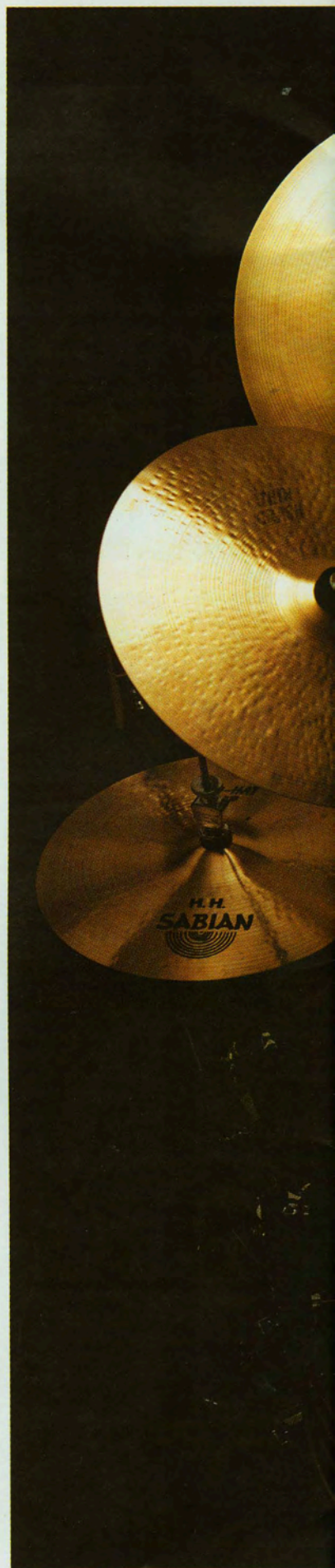







# Sticks Mallets Brushes

Sonor Drum Sticks are made from first-quality hickory and maple wood.

- Z 5613** Sonor Hickory with wood tip (3, 4, 5, 6, 8)
- Z 5614** Sonor Maple with wood tip (7, 10)
- Z 5615** Sonor Hickory with nylon tip (3N, 4N, 5N, 8N)
- Sch 107** Tom Tom Mallet with flannel head

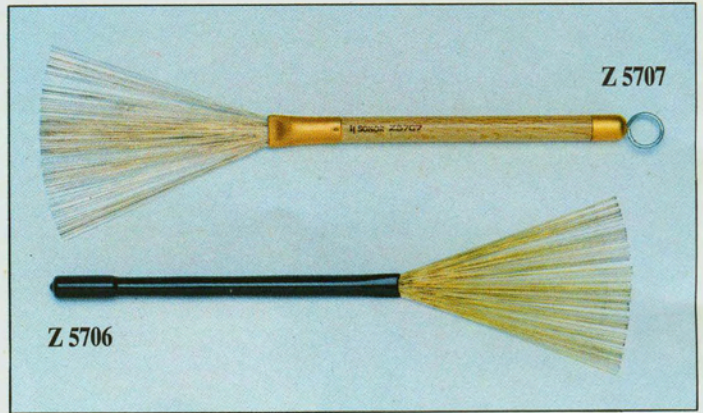

- Sch 60** Tom Tom Mallet with felt head
- Z 5707** brushes with wooden shaft and loop end
- Z 5706** brushes with plastic shaft

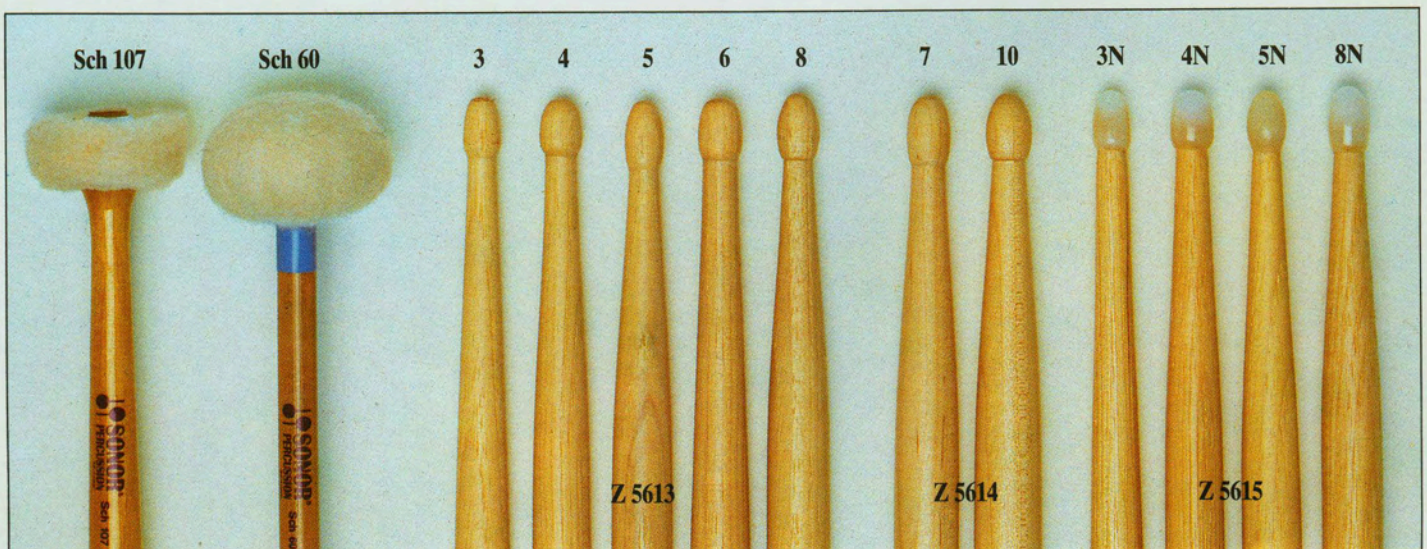



SD 6 Swizzle B

Vic Firth drum sticks are made from hand-selected hickory and maple and are always of the same form and weight. Strict controls ensure unvarying quality and excellent finish of these drum sticks.

**Z 5616** Vic Firth Hickory with wood tip (5A, 5B, 7A, 8D, Rock)

**Z 5616** Vic Firth Maple with wood tip (SD9, SD1, SD2)

**Z 5617** Vic Firth Hickory with nylon tip (5AN, 5BN)

Pro Mark drum sticks are made from selected Japanese Oak.

**Z 5606** Pro Mark White Oak with wood tip (808, 3A, 747, 5B, 11A, Professional)

**Z 5607** Pro Mark White Oak with nylon tip (747N, 7AN, 3AN)

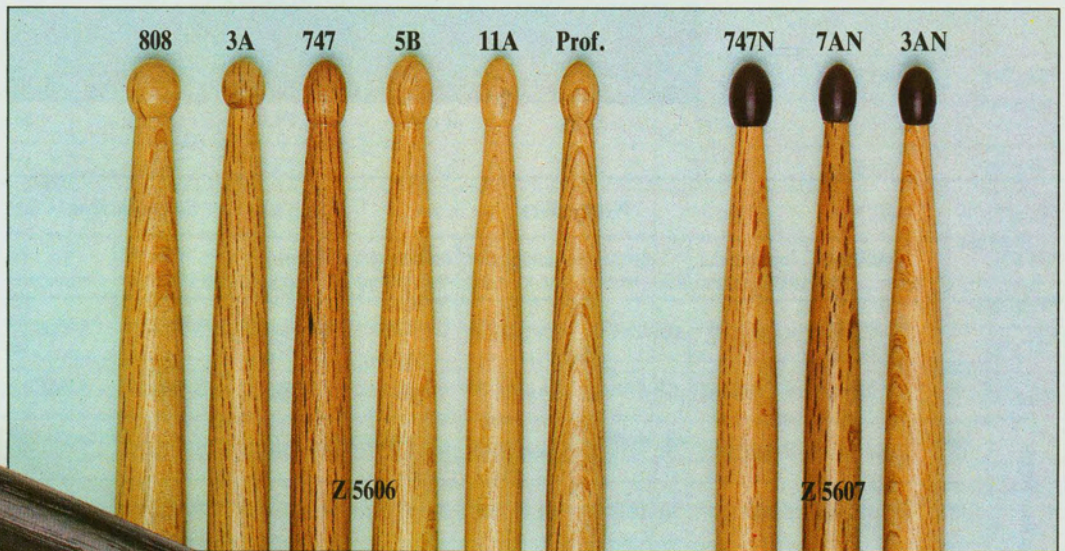
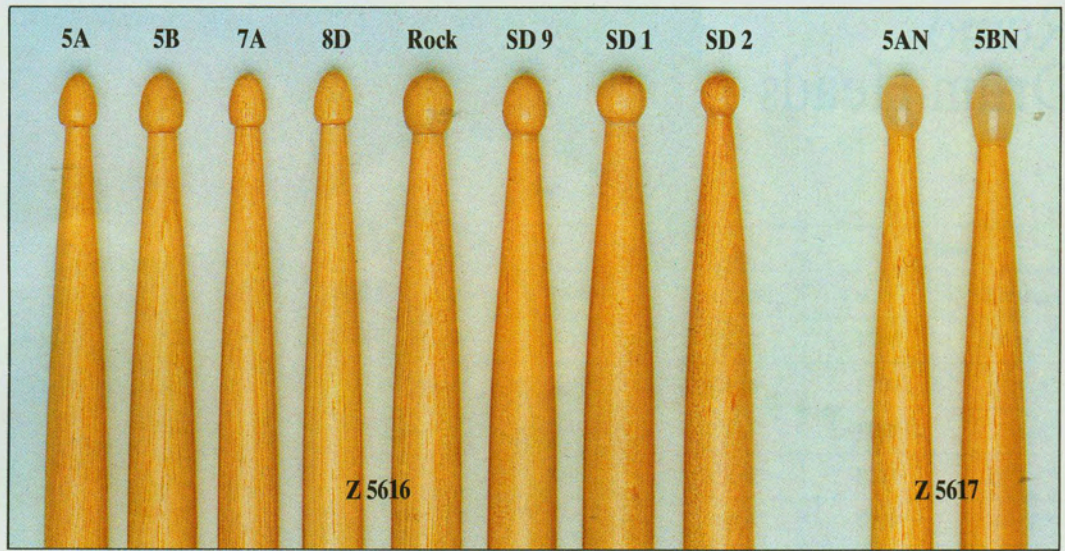

**Z 5616** "Steve Gadd Model" Vic Firth, made of selected hickory, black finish



# Remo Drum Heads

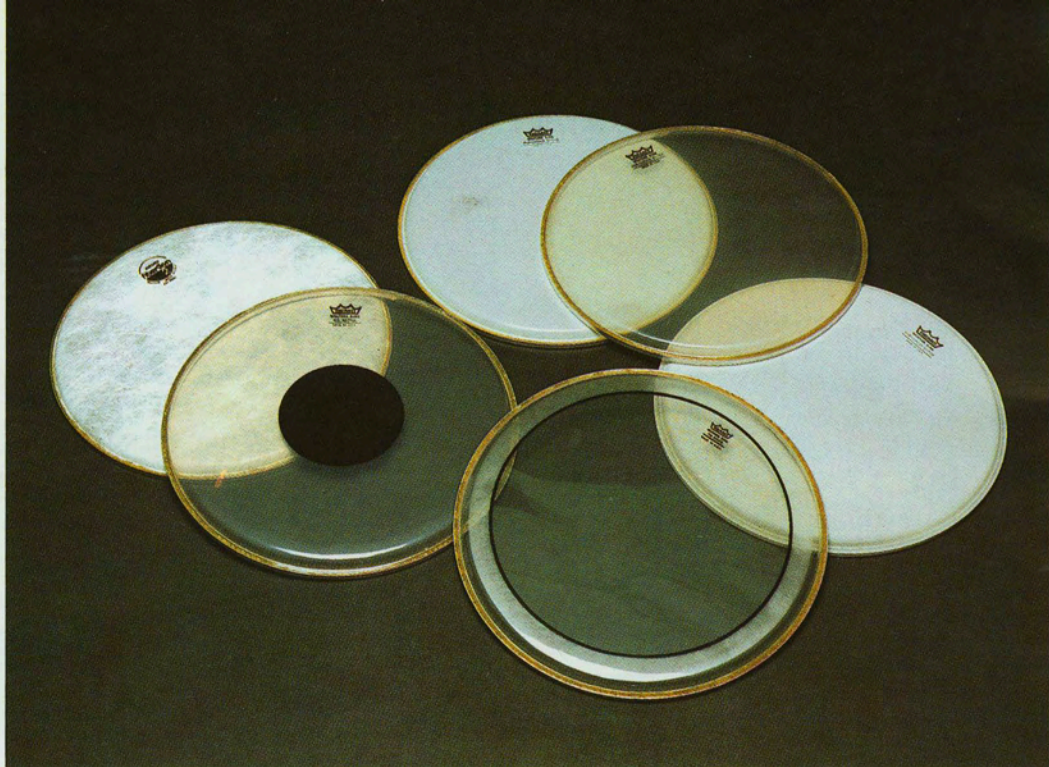

Head dia.	Weather King						Controlled Sound CS		Pin Stripe	Fiber Skyn 2		
	Diplomat white, coated	Ambassador white, coated	Emperor white, coated	Ambassador smooth white	Ambassador transparent	Emperor transparent	CS smooth white	CS transparent	transparent	medium	thin	
Snare Drum and Tom Tom Heads	6"	BD-0106-00	BA-0106-00	BE-0106-00	BA-0206-00	BA-0306-00	BE-0306-00	CS-0206-10	CS-0306-10	PS-0306-00	FM-0506-00	FT-0506-00
	8"	BD-0108-00	BA-0108-00	BE-0108-00	BA-0208-00	BA-0308-00	BE-0308-00	CS-0208-10	CS-0308-10	PS-0308-00	FM-0508-00	FT-0508-00
	10"	BD-0110-00	BA-0110-00	BE-0110-00	BA-0210-00	BA-0310-00	BE-0310-00	CS-0210-10	CS-0310-10	PS-0310-00	FM-0510-00	FT-0510-00
	12"	BD-0112-00	BA-0112-00	BE-0112-00	BA-0212-00	BA-0312-00	BE-0312-00	CS-0212-10	CS-0312-10	PS-0312-00	FM-0512-00	FT-0512-00
	13"	BD-0113-00	BA-0113-00	BE-0113-00	BA-0213-00	BA-0313-00	BE-0313-00	CS-0213-10	CS-0313-10	PS-0313-00	FM-0513-00	FT-0513-00
	14"	BD-0114-00	BA-0114-00	BE-0114-00	BA-0214-00	BA-0314-00	BE-0314-00	CS-0214-10	CS-0314-10	PS-0314-00	FM-0514-00	FT-0514-00
	15"	BD-0115-00	BA-0115-00	BE-0115-00	BA-0215-00	BA-0315-00	BE-0315-00	CS-0215-10	CS-0315-10	PS-0315-00	FM-0515-00	FT-0515-00
	16"	BD-0116-00	BA-0116-00	BE-0116-00	BA-0216-00	BA-0316-00	BE-0316-00	CS-0216-10	CS-0316-10	PS-0316-00	FM-0516-00	FT-0516-00
	18"	BD-0118-00	BA-0118-00	BE-0118-00	BA-0218-00	BA-0318-00	BE-0318-00	CS-0218-10	CS-0318-10	PS-0318-00	FM-0518-00	FT-0518-00
Bass Drum Heads	18"	-	BR-1118-00	BB-1118-00	BR-1218-00	BR-1318-00	BB-1318-00	CS-1218-10	CS-1318-00	PS-1318-00	FM-1518-00	-
	20"	-	BR-1120-00	BB-1120-00	BR-1220-00	BR-1320-00	BB-1320-00	CS-1220-10	CS-1320-00	PS-1320-00	FM-1520-00	-
	22"	-	BR-1122-00	BB-1122-00	BR-1222-00	BR-1322-00	BB-1322-00	CS-1222-10	CS-1322-00	PS-1322-00	FM-1522-00	-
	24"	-	BR-1124-00	BB-1124-00	BR-1224-00	BR-1324-00	BB-1324-00	CS-1224-10	CS-1324-00	PS-1324-00	FM-1524-00	-
	26"	-	BR-1126-00	BB-1126-00	BR-1226-00	BR-1326-00	BB-1326-00	CS-1226-10	CS-1326-00	PS-1326-00	FM-1526-00	-
Snare Heads	13"	SD-0113-00	SA-0113-00	SE-0113-00	-	-	-	-	-	-	-	-
	14"	SD-0114-00	SA-0114-00	SE-0114-00	-	-	-	-	-	-	-	-
	15"	SD-0115-00	SA-0115-00	SE-0115-00	-	-	-	-	-	-	-	-



# Master Series Chart

	Shell dia.	Signature Series		Sonorlite		Phonic Plus		Phonic	
		Cat. No.	Shell sizes	Cat. No.	Shell sizes	Cat. No.	Shell sizes	Cat. No.	Shell sizes
Tom Toms	8"	<b>HLT 8</b>	8" x 8"	<b>LT 8</b>	8" x 8"	<b>T 8</b>	8" x 8"	<b>T 780</b>	8" x 8"
	10"	<b>HLT 10</b>	10" x 10"	<b>LT 10</b>	10" x 9"	<b>T 10</b>	10" x 10"	<b>T 720</b>	10" x 8"
	12"	<b>HLT 12</b>	12" x 12"	<b>LT 12</b>	12" x 10"	<b>T 12</b>	12" x 12"	<b>T 722</b>	12" x 8"
	13"	<b>HLT 13</b>	13" x 13"	<b>LT 13</b>	13" x 11"	<b>T 13</b>	13" x 13"	<b>T 723</b>	13" x 9"
	14"	<b>HLT 14</b>	14" x 14"	<b>LT 14</b>	14" x 12"	<b>T 14</b>	14" x 14"	<b>T 724</b>	14" x 10"
	15"	<b>HLT 15</b>	15" x 15"	<b>LT 15</b>	15" x 13"	<b>T 15</b>	15" x 15"	<b>T 725</b>	15" x 12"
	16"	<b>HLT 16</b>	16" x 16"	-	-	-	-	-	-
Floor Toms	14"	<b>HLFT 14</b>	14" x 16"	<b>LFT 14</b>	14" x 15"	-	-	<b>T 734</b>	14" x 14"
	15"	<b>HLFT 15</b>	15" x 17"	<b>LFT 15</b>	15" x 16"	<b>FT 15</b>	15" x 17"	-	-
	16"	<b>HLFT 16</b>	16" x 18"	<b>LFT 16</b>	16" x 17"	<b>FT 16</b>	16" x 18"	<b>T 736</b>	16" x 16"
	18"	<b>HLFT 18</b>	18" x 19"	<b>LFT 18</b>	18" x 18"	<b>FT 18</b>	18" x 19"	<b>T 738</b>	18" x 16"
Bass Drums	18"	<b>HLG 18</b>	18" x 16"	<b>LG 18</b>	18" x 15"	-	-	<b>G 318</b>	18" x 14"
	20"	<b>HLG 20</b>	20" x 17"	<b>LG 20</b>	20" x 16"	<b>G 20</b>	20" x 17"	<b>G 320</b>	20" x 14"
	22"	<b>HLG 22</b>	22" x 18"	<b>LG 22</b>	22" x 17"	<b>G 22</b>	22" x 18"	<b>G 322</b>	22" x 14"
	24"	<b>HLG 24</b>	24" x 18"	<b>LG 24</b>	24" x 17"	<b>G 24</b>	24" x 18"	<b>G 324</b>	24" x 14"
Snare Drums	Shell depth	Signature Serie		Sonorlite		Phonic Plus		Phonic	
	3½"	-	-	-	-	-	-	<b>D 420</b>	14" x 3½"
	5¾"	-	-	-	-	-	-	<b>D 505</b>	14" x 5¾"
	6½"	<b>HLD 581, 582</b>	14" x 6½"	-	-	-	-	<b>D 506, 516</b>	14" x 6½"
	7¼"	-	-	<b>LD 557, 547x</b>	14 x 7¼"	-	-	-	-
	8"	<b>HLD 580, 588</b>	14" x 8"	-	-	<b>D 508x, 518x</b>	14" x 8"	-	-

Features at a glance	Signature Series				Sonorlite				Phonic/Phonic Plus				Phonic/Phonic Plus				Performer			
	Heavy		Light						with gloss finish				with wood finish							
12-ply shell	●	●	●	●	●	●	●	●	●	●	●	●	●	●	●	●	●	●	●	●
9-ply shell									●	●	●	●	●	●	●	●	●	●	●	●
6-ply shell																			●	●
12 mms shell	●	●	●	●																
10 mms shell									●	●	●	●					●			
9 mms shell													●	●	●	●				
7 mms shell					●	●	●	●	●	●									●	●
6 mms shell									●	●										
Beech	●	●	●	●					●	●	●	●	●	●	●	●	●	●	●	●
Birch					●	●	●	●	●	●	●	●								



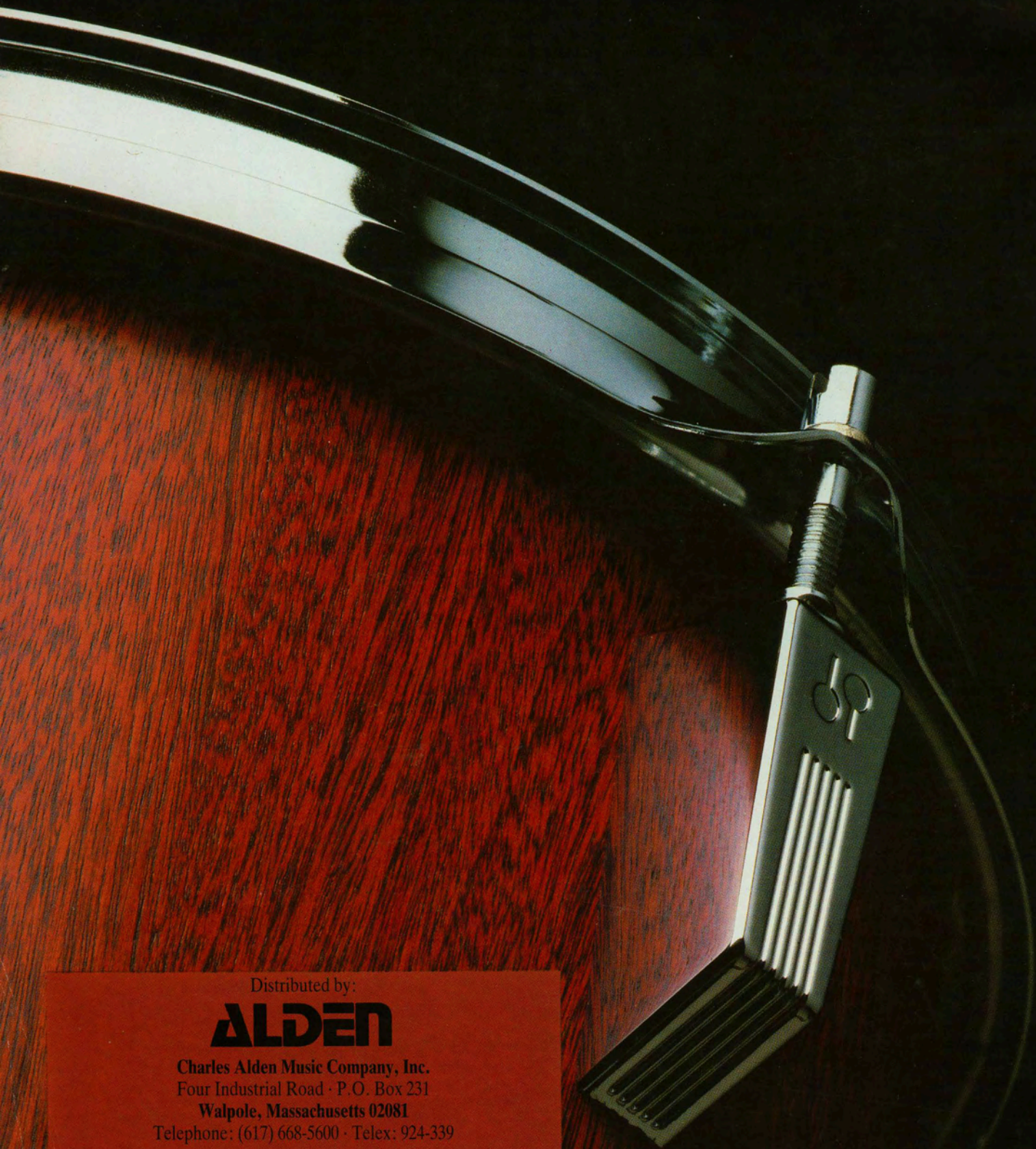

Distributed by:

**ALDEN**

Charles Alden Music Company, Inc.  
Four Industrial Road · P.O. Box 231  
Walpole, Massachusetts 02081  
Telephone: (617) 668-5600 · Telex: 924-339

© 1984 Johs. Link KG · Printed in Germany