

SINCE 1924
Sam Ash MUSIC STORES
MUSICAL INSTRUMENTS
SOLD • REPAIRED • RENTED
BROOKLYN • HEMPSTEAD • MANHATTAN
HUNTINGTON STATION • WHITE PLAINS

TAMA DRUMS

BILLY COBHAM





SUPERSTAR
9600 Series
 AVAILABLE COLOR



NATURAL MAPLE



NATURAL WALNUT



M-58 PLATINA

FIBRESTAR
9200 Series
 AVAILABLE COLOR



M-58 PLATINA



M-53 METALIC WHITE



M-55 MIDNIGHT BLUE
(METALIC BLACK)

IMPERIALSTAR
8500 Series
 AVAILABLE COLOR



M-58 PLATINA



M-53 METALIC WHITE



M-55 MIDNIGHT BLUE
(METALIC BLACK)



M-60 HAIRLINE CHROME



P-28 JET BLACK



M-54 METALIC GOLD



M-52 METALIC BLUE



M-51 METALIC RED

THE STRONGEST NEW NAME IN DRUMS

TAMA SUPERSTAR

... is the strongest new wood shell in the industry. The exclusive Tama "heat compression" process assures a perfectly round shell that won't warp and won't de-laminate. The specially selected hard birch and specially compounded adhesives combine to make a shell that's both tough and resonant, with all the warm and fat tones you could ask for.

Superstar drums are available in natural or walnut stain lacquer finishes or in Tama Platina for a more roadworthy finish.

TAMA FIBRESTAR

... AT LAST, A FIBREGLASS SHELL WITH TONE! Tama Fibrestar drums are carefully constructed of layered-up fibreglass. And not just any fibreglass, either. Tama uses only "Black Fibre" fibreglass, the strongest there is. The special Tama finishing process puts the most accurate sound edge on the shell. Expect a powerful and brilliant tone from Tama Fibrestar Drums!

TAMA IMPERIALSTAR

THE HEAVYWEIGHT Tama Imperialstar drums have become the heavyweight standard of the industry. Tried and proven on the road and in the studio. The 9-ply heat compressed shell is additionally strengthened by reinforcement rims. The inside of Imperial Star shells is finished with the exclusive "Zola-Coat". This finish provides a perfect moisture barrier for consistency of sound.

TAMA "NO SPRING" LUGS

Heavy duty Tama lugs are mirror chrome plated and feature the Tama Exclusive "No Spring" insert. A nylon bushing retains the insert and eliminates rattles and collapsed springs. Tama Drum lugs are threaded to U.S. Standard threads to accept any U.S. made drum rod.

TAMA 2-WAY SPURS AND LEGS

Tama bass drum spurs and tom tom legs feature the Tama 2-Way convertible tip. The rubber tip easily retracts to expose a sharp and gripping anchor tip. Tama bass drum spurs are also slanted forward 15° to virtually eliminate bass drum creep.

TAMA TOM TOM HOLDERS

The heaviest and most versatile in the industry. All Tama tom toms and concert toms have the same brackets, so mixing types and sizes no longer presents any set-up problems. Now it's easier than ever before to custom design your own Tama set.

TAMA "ONE-TOUCH" TONE CONTROL

The only tone control that allows you to preset the precise amount of muting, and then bring it in and out with the flick of a knob.

TAMA SHELL SUPPORTER

With many drummers playing single headed bass drums, the Tama shell support can perform several functions. It will prevent ovaling of the shell due to tom tom weight, prevent damage in transit, and keep a pillow or other muffler in place.

TAMA SNARE DRUMS-THREE SHELLS-THREE STRAINERS

Whatever your purpose or preference, Tama has the combination for you. Seamless metal, Black fibreglass, or natural wood, with either **HG** parallel action, **CL** compound lever, or **SS** single side adjustment strainers.

TAMA HARDWARE-THE NEW STANDARD OF THE INDUSTRY

And now a step further ahead with the choice of three leg styles to fit your choice. Single leg, double leg or the new aluminum die-cast legs with 2-way tips. The telescoping sections of Tama stands are all fitted with the Tama exclusive nylon bushing clamp. This special design requires only fingertip pressure to hold firmly and will not bend, dent or distort the stand shafts. Tama—the makers of the original cymbal boom stand are still far ahead of the closest competition.

NEW TAMA KING-BEAT BASS DRUM PEDAL

The most distinctive and versatile new pedal in years. It features: adjustable footboard heel, adjustable compression spring, adjustable beater stroke angle, and a new one-touch rim clamp for easy set up.

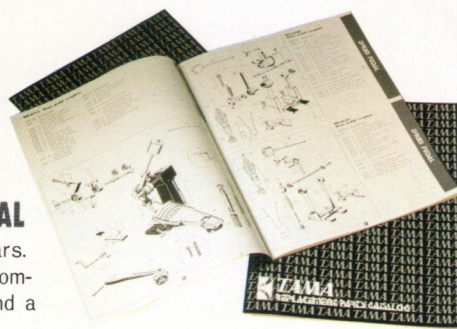
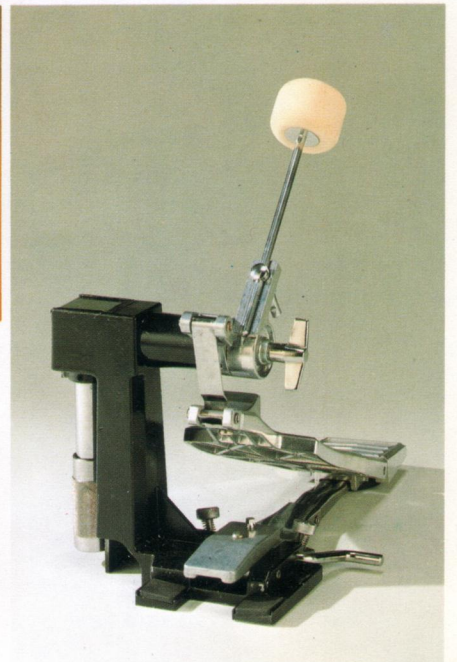
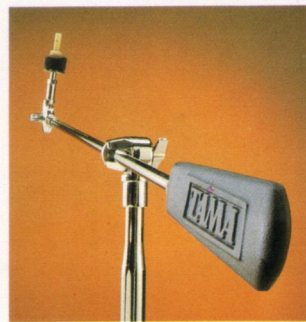
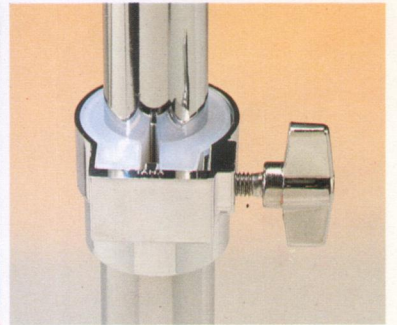
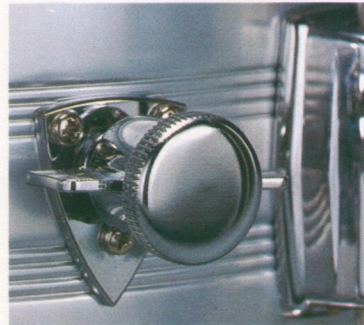
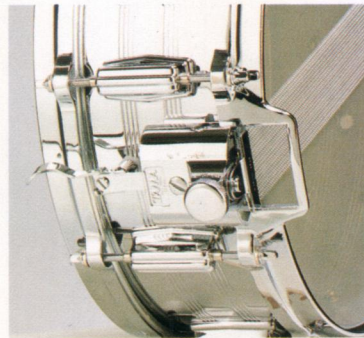
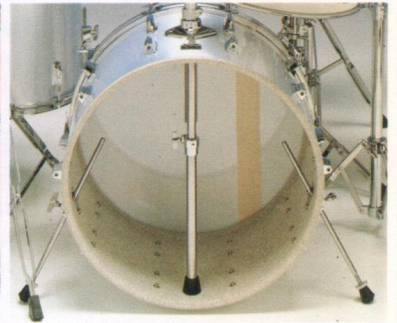
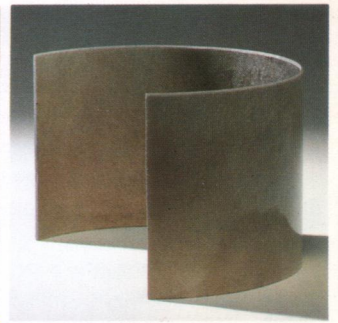
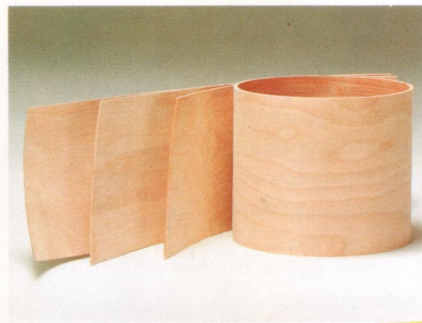

SUPERSTAR 9600 SERIES

TAMA SUPERSTAR 9600

Tama Superstar Drums—the warmest wood sound around. Only the most select and specially cured birch is heat compression formed into Tama Superstar shells. Tama ambassador heads are fitted for a big, warm and fat tone you'll have to play yourself to appreciate.

Hardware—Superstar drum outfits feature Tama SPARTAN hardware with new die-cast legs for lightweight strength. The stands feature 2-way convertible tips for stability on any surface. The hardware also features nylon bushing clamps for secure position and years of trouble free service.

Tama Superstar outfits also feature the new King-Beat bass drum pedal. This pedal features an entirely new footboard concept, designed for durability and comfort. The footboard is curved to fit the sole of your shoe. The toe stopper and deep anti-skid grooves combine to prevent slipping. And the heel height is adjustable to the most comfortable and least fatiguing position.

And to put the drive into your Superstar set is the new Tama King beat snare with a seamless metal shell and die cast hoops. The KG parallel action snare strainer is the smoothest and most adjustable ever offered.

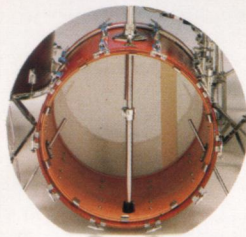

AVAILABLE DRUM SIZES

BASS DRUMS

9618	14"×18"	9620	14"×20"
9622	14"×22"	9624	14"×24"

TOM TOMS

9612	8"×12"	9613	9"×13"
9614	10"×14"	9615	12"×15"

FLOOR TOM TOMS

9634	14"×14"	9636	16"×16"
9638	16"×18"		

CONCERT TOM TOMS

9663	9"×13"	9664	10"×14"
9665	12"×15"	9666	14"×16"

AVAILABLE DRUM FINISHES

- Natural Maple (mat finish)
- Natural Walnut (mat finish)
- Plantina (covered finish)



SUPERSTAR 9T OUTFIT NO.9049

- 9622 14"×22" Bass drums (2)
- 6682 Double tom tom holders (2)
- 8005 5"×14" Metal snare drum
- 9612 8"×12" Tom tom
- 9613 9"×13" Tom tom
- 9614 10"×14" Tom tom
- 9615 12"×15" Tom tom
- 9636 16"×16" Floor tom tom
- 9638 16"×18" Floor tom tom
- 6755.....Drum pedals (2)
- 6920.....Snare drum stand
- 6925.....Hi-hat stand
- 6922.....Cymbal stands (2)
- 6082.....Drum sticks

Cymbals not included.
Finish shown: Natural Maple.





SUPERSTAR
OUTFIT NO.9040 **5T/22**

- 9622 14"×22" Bass drum
- 6682 Double tom tom holder
- 8005 5"×14" Metal snare drum
- 9612 8"×12" Tom tom
- 9613 9"×13" Tom tom
- 9636 16"×16" Floor tom tom
- 6755.....Drum pedal.
- 6920.....Snare drum stand.
- 6925.....Hi-hat stand.
- 6922.....Cymbal stands (2)
- 6082.....Drum sticks.

Cymbals not included.
Finish shown : Natural Walnut.



SUPERSTAR
OUTFIT NO.9034 **4T/18**

- 9618 14"×18" Bass drum
- 6681 Single tom tom holder
- 8005 5"×14" Metal snare drum
- 9612 8"×12" Tom tom
- 9634 14"×14" Floor tom tom
- 6755.....Drum pedal
- 6920.....Snare drum stand
- 6925.....Hi-hat stand
- 6922.....Cymbal stands (2)
- 6080.....Drum sticks
- 6095.....Wire brushes

Cymbals not included.
Finish shown : Platina.



FIBRESTAR 9200 SERIES

TAMA FIBRESTAR 9200

The layered-up fibreglass shell and special lathe-finished sound edge add up to the most precise fibreglass shell ever made. Fibre-Star sets are fitted with Tama CS heads for a solid punchy tone with unequalled power and attack.

Fibre-Star drum outfits feature Tama Titan twin leg hardware. Titan hardware has earned a reputation for roadie-proof durability with some of America's hardest playing and hardest touring bands. The new nylon bushing clamps are already getting rave reviews from professional drummers.

The new King-Beat bass drum pedal uses a new compression spring principle that gives a more consistent and smoother action than any other system. The external adjustment gives you the opportunity to fine tune the King-Beat pedal quickly and without hassles.

Fibre-Star outfits also feature the new Tama King-Beat snare. The new King-Beat strainer features separate tension and head pressure adjustments for the "just right" sound.

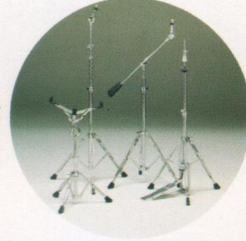
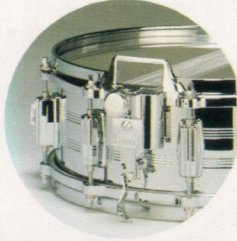
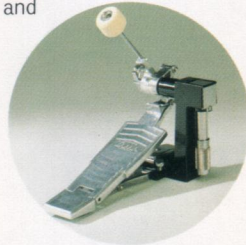
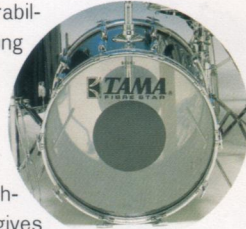
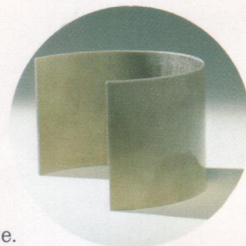

AVAILABLE DRUM SIZES

BASS DRUMS

9222CS 14" x 22" 9224CS 14" x 24"

TOM TOMS

9212CS 8" x 12" 9213CS 9" x 13"
9214CS 10" x 14" 9215CS 12" x 15"

FLOOR TOM TOMS

9234CS 14" x 14" 9236CS 16" x 16"
9238CS 16" x 18"

CONCERT TOM TOMS

9256 5 1/2" x 6" 9258 5 1/2" x 8"
9260 6 1/2" x 10" 9262 8" x 12"
9263 9" x 13" 9264 10" x 14"
9265 12" x 15" 9266 14" x 16"

AVAILABLE DRUM FINISHES

- M-58 Platina
- M-55 Midnight Blue
(Metalic Black)
- M-53 Metalic White



FIBRESTAR FS-8X OUTFIT NO.9298

- 9222CS 14" x 22" Bass drum
- 6682 Double tom tom holder
- 8005 5" x 14" Metal snare drum
- 9213CS 9" x 13" Tom tom
- 9214CS 10" x 14" Tom tom
- 9260 6 1/2" x 10" Concert tom tom
- 9262 8" x 12" Concert tom tom
- 9236CS 16" x 16" Floor tom tom
- 9238CS 16" x 18" Floor tom tom

- 6755..... Drum pedal
- 6890..... Snare drum stand
- 6895..... Hi-hat stand
- 6892..... Cymbal stand
- 6894..... Cymbal stand
- 6899..... Tom tom stand
- 6082..... Drum sticks

Cymbals not included.
Finish shown: M-55 Midnight Blue.
(Metalic Black)



FIBRESTAR OUTFIT NO.9294 **FS-4T**

- 9222CS 14"×22" Bass drum
- 6681 Single tom tom holder
- 8005 5"×14" Metal snare drum
- 9213CS 9"×13" Tom tom
- 9236CS 16"×16" Floor tom tom

- 6755.....Drum pedal
- 6890.....Snare drum stand
- 6895.....Hi-hat stand
- 6892.....Cymbal stand
- 6894.....Cymbal stand
- 6082.....Drum sticks

Cymbals not included.



FIBRESTAR OUTFIT NO.9295 **FS-5T**

- 9222CS 14"×22" Bass drum
- 6682 Double tom tom holder
- 8005 5"×14" Metal snare drum
- 9212CS 8"×12" Tom tom
- 9213CS 9"×13" Tom tom
- 9236CS 16"×16" Floor tom tom

- 6755.....Drum pedal
- 6890.....Snare drum stand
- 6895.....Hi-hat stand
- 6892.....Cymbal stand
- 6894.....Cymbal stand
- 6082.....Drum sticks

Cymbals not included.



FIBRESTAR OUTFIT NO.9296 **FS-6T**

- 9222CS 14"×22" Bass drum
- 6682-3T Triple tom tom holder
- 8005 5"×14" Metal snare drum
- 9212CS 8"×12" Tom tom
- 9213CS 9"×13" Tom tom
- 9214CS 10"×14" Tom tom
- 9236CS 16"×16" Floor tom tom

- 6755.....Drum pedal
- 6890.....Snare drum stand
- 6895.....Hi-hat stand
- 6892.....Cymbal stand
- 6894.....Cymbal stand
- 6082.....Drum sticks

Cymbals not included.



FIBRESTAR OUTFIT NO.9299 **FS-9C**

- 9224CS 14"×24" Bass drum
- 6682 Double tom tom holder
- 8005 5"×14" Metal snare drum
- 9260 6½"×10" Concert tom tom
- 9262 8"×12" Concert tom tom
- 9263 9"×13" Concert tom tom
- 9264 10"×14" Concert tom tom
- 9265 12"×15" Concert tom tom
- 9266 14"×16" Concert tom tom
- 9238 16"×18" Floor tom tom

- 6755.....Drum pedal
- 6890.....Snare drum stand
- 6895.....Hi-hat stand
- 6892.....Cymbal stand
- 6894.....Cymbal stand
- 6899.....Tom tom stands (2)
- 6082.....Drum sticks

Cymbals not included.

Finish shown : M-55 Midnight Blue.
(Metallic Black)

IMPERIALSTAR 8500CS SERIES

TAMA IMPERIALSTAR 8500CS

The 9-ply heat-compression shell is additionally strengthened by two reinforcing rims inside the shell. The inside of the shell is finished in a special "Zola Coat" to seal out moisture. Imperialstar 8500CS sets are equipped with Remo CS Controlled sound heads for the powerful sound of today's music. Imperialstar Saturn Series outfits include Tama concert toms with new Tama All-Angle hardware.

Imperialstar drum outfits feature Tama Titan twin leg hardware. Tama Titan hardware has earned a reputation for roadie-proof durability with some of America's hardest playing and hardest touring bands. The new nylon bushing-clamps are already getting rave reviews from professional drummers.

The new Tama King-Beat pedal features an adjustable stroke angle, completely independent of spring tension and footboard angle. The impact angle of the beater is precisely calculated to put the power where you need it on the drum head.

The new Tama King-Beat snare features Tama PC die-cast hoops. PC hoops are die-cast to a perfect circle for perfect alignment and fit of the head and the shell.

And since PC hoops don't bend or give, rimshots are bigger, louder and cleaner.

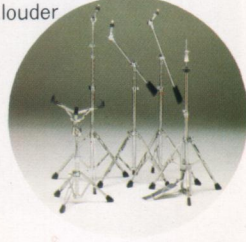
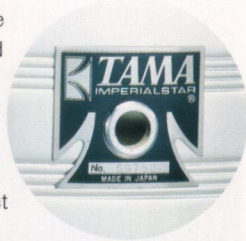
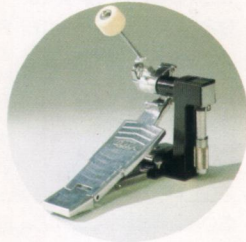

AVAILABLE DRUM SIZES

BASS DRUMS

8522CS 14" x 22" 8524CS 14" x 24"

TOM TOMS

8512CS 8" x 12" 8513CS 9" x 13"
8514CS 10" x 14" 8515CS 12" x 15"

FLOOR TOM TOMS

8536CS 16" x 16" 8538CS 16" x 18"

CONCERT TOM TOMS

8556 5 1/2" x 6" 8558 5 1/2" x 8"
8560 6 1/2" x 10" 8562 8" x 12"
8563 9" x 13" 8564 10" x 14"
8565 12" x 15" 8566 14" x 16"

AVAILABLE DRUM FINISHES

- M-58 Platina
- M-55 Midnight Blue (Metalic Black)
- M-53 Metalic White



IMPERIALSTAR SATURN 12+1 OUTFIT NO.8993

- 8522CS 14" x 22" Bass drums (2)
- 6682 Double tom tom holders (2)
- 8005 5" x 14" Metal snare drum
- 8556 5 1/2" x 6" Concert tom tom
- 8558 5 1/2" x 8" Concert tom tom
- 8560 6 1/2" x 10" Concert tom tom
- 8562 8" x 12" Concert tom tom
- 8563 9" x 13" Concert tom tom
- 8564 10" x 14" Concert tom tom
- 8565 12" x 15" Concert tom tom
- 8566 14" x 16" Concert tom tom
- 8536CS 16" x 16" Floor tom tom
- 8538CS 16" x 18" Floor tom tom
- 6755.....Drum pedals (2)
- 6890.....Snare drum stand
- 6895.....Hi-hat stand
- 6892.....Cymbal stand
- 6894.....Cymbal stands (2)
- 6899.....Tom tom stands (2)
- 6082.....Drum sticks

Cymbals not included.
Finish shown: M-58 Platina.

IMPERIALSTAR SATURN 9

OUTFIT NO.8989

- 8522CS 14" x 22" Bass drum
- 6682 Double tom tom holder
- 8005 5" x 14" Metal snare drum
- 8560 6 1/2" x 10" Concert tom tom
- 8562 8" x 12" Concert tom tom
- 8563 9" x 13" Concert tom tom
- 8564 10" x 14" Concert tom tom
- 8565 12" x 15" Concert tom tom
- 8566 14" x 16" Concert tom tom
- 8538CS 16" x 18" Floor tom tom

- 6755.....Drum pedal
- 6890.....Snare drum stand
- 6895.....Hi-hat stand
- 6892.....Cymbal stand
- 6894.....Cymbal stands (2)
- 6899.....Tom tom stands (2)
- 6082.....Drum sticks

Cymbals not included.
Finish shown : M-58 Platina



IMPERIALSTAR SATURN 7

OUTFIT NO.8987

- 8522CS 14" x 22" Bass drum
- 6682 Double tom tom holder
- 8005 5" x 14" Metal snare drum
- 8563 9" x 13" Concert tom tom
- 8564 10" x 14" Concert tom tom
- 8565 12" x 15" Concert tom tom
- 8566 14" x 16" Concert tom tom
- 8538CS 16" x 18" Floor tom tom

- 6755.....Drum pedal
- 6890.....Snare drum stand
- 6895.....Hi-hat stand
- 6892.....Cymbal stand
- 6894.....Cymbal stands (2)
- 6899.....Tom tom stand
- 6082.....Drum sticks

Cymbals not included.
Finish shown : M-58 Platina

IMPERIALSTAR 8500 SERIES

TAMA IMPERIALSTAR 8500

The 9-ply Imperialstar shell is heat compression formed and additionally strengthened by two reinforcement rims. The "Zola Coat" tone finish completely seals out moisture for assured consistent tone. Imperialstar 8500 Series sets are fitted with Tama Ambassador heads for the best all-purpose performance. The bass drums feature metal hoops for added strength. The special profile of the hoop is designed to provide an excellent mount for the bass drum pedal.

Imperialstar outfits feature Tama Titan twin leg hardware. Titan hardware has earned the reputation for roadie-proof durability with some of America's hardest playing and hardest touring bands. The new nylon bushing-clamps are already getting rave reviews from professional drummers.

The new Tama King-Beat pedal is the most innovative pedal to hit the market in years. It's designed for the most effective transfer of power from your foot to the drum head, so you can play faster, louder and longer with less fatigue.

The new Tama King-Beat snare features a deep-drawn seamless shell for consistency of response around the drum. The sound edge is a mere 2mm radius for nearly unlimited freedom of head vibration.

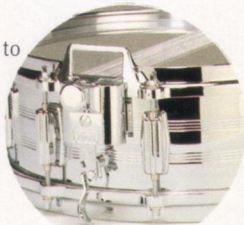
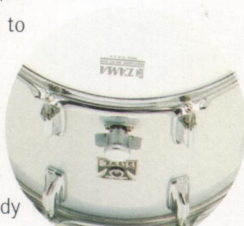
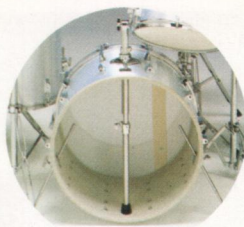

AVAILABLE DRUM SIZES

BASS DRUMS

8518	14" x 18"	8520	14" x 20"
8522	14" x 22"	8524	14" x 24"
8526	14" x 26"		

TOM TOMS

8512	8" x 12"	8513	9" x 13"
8514	10" x 14"	8515	12" x 15"

FLOOR TOM TOMS

8534	14" x 14"	8536	16" x 16"
8538	16" x 18"		

CONCERT TOM TOMS

8556	5 1/2" x 6"	8558	5 1/2" x 8"
8560	6 1/2" x 10"	8562	8" x 12"
8563	9" x 13"	8564	10" x 14"
8565	12" x 15"	8566	14" x 16"

AVAILABLE DRUM FINISHES

- M-51 Metallic Red
- M-52 Metallic Blue
- M-53 Metallic White
- M-54 Metallic Gold
- M-55 Midnight Blue (Metalic Black)
- M-58 Platina
- M-60 Hairline Chrome
- P-28 Jet Black

IMPERIALSTAR MARS 8 OUTFIT NO.8908

- 8524 14" x 24" Bass drum
- 6682 Double tom tom holder
- 8005 5" x 14" Metal snare drum
- 8512 8" x 12" Tom tom
- 8513 9" x 13" Tom tom
- 8514 10" x 14" Tom tom
- 8515 12" x 15" Tom tom
- 8536 16" x 16" Floor tom tom
- 8538 16" x 18" Floor tom tom
- 6755.....Drum pedal
- 6890.....Snare drum stand
- 6895.....Hi-hat stand
- 6892.....Cymbal stands (2)
- 6899.....Tom tom stand
- 6082.....Drum sticks

Cymbals not included.
Finish shown: M-53 Metallic White.



IMPERIALSTAR MARS 4 OUTFIT NO.8904

- 8522 14"×22" Bass drum
- 6681 Single tom tom holder
- 8005 5"×14" Metal snare drum
- 8513 9"×13" Tom tom
- 8536 16"×16" Floor tom tom
- 6755.....Drum pedal
- 6890.....Snare drum stand
- 6895.....Hi-hat stand
- 6892.....Cymbal stands (2)
- 6082.....Drum sticks

Cymbals not included.



IMPERIALSTAR MARS 5A OUTFIT NO.8935

- 8522 14"×22" Bass drum
- 6682 Double tom tom Holder
- 8005 5"×14" Metal snare drum
- 8512 8"×12" Tom tom
- 8513 9"×13" Tom tom
- 8536 16"×16" Floor tom tom
- 6755.....Drum pedal
- 6890.....Snare drum stand
- 6895.....Hi-hat stand
- 6892.....Cymbal stands (2)
- 6082.....Drum sticks

Cymbals not included.



IMPERIALSTAR MARS 6 OUTFIT NO.8936

- 8522 14"×22" Bass drum
- 6682-3T Triple tom tom holder
- 8005 5"×14" Metal snare drum
- 8512 8"×12" Tom tom
- 8513 9"×13" Tom tom
- 8514 10"×14" Tom tom
- 8536 16"×16" Floor tom tom
- 6755.....Drum pedal
- 6890.....Snare drum stand
- 6895.....Hi-hat stand
- 6892.....Cymbal stands (2)
- 6082.....Drum sticks

Cymbals not included.



IMPERIALSTAR MERCURY OUTFIT

HI-BEAT DRUM PEDAL NO.6740
Adjustable beater stroke angle.
Easy spring adjustment.
Built-in anchor.
Positive beater clamp.
Heavy duty cam strap.

METAL SNARE DRUM NO.8045
Seamless metal shell.
TAMA PC die-cast hoops.
One-touch tone control.
TAMA ambassador drum heads.
CL compound lever strainer.

MERCURY DRUM STANDS
Single legs with wide-stance tripod base.
Excellent stability and light weight.



IMPERIALSTAR MERCURY 4 OUTFIT NO.8704

- 8522 14"×22" Bass drum
- 6681 Single tom tom holder
- 8045 5"×14" Metal snare drum
- 8513 9"×13" Tom tom
- 8536 16"×16" Floor tom tom
- 6740.....Drum pedal
- 6870.....Snare drum stand
- 6875.....Hi-hat stand
- 6872.....Cymbal stands (2)
- 6080.....Drum sticks
- 6095.....Wire brushes

Finish shown: M-54 Metallic Gold.
Cymbals not included.



IMPERIALSTAR MERCURY 5 OUTFIT NO.8705

- 8522 14"×22" Bass drum
- 6682 Double tom tom holder
- 8045 5"×14" Metal snare drum
- 8512 8"×12" Tom tom
- 8513 9"×13" Tom tom
- 8536 16"×16" Floor tom tom
- 6740.....Drum pedal
- 6870.....Snare drum stand
- 6875.....Hi-hat stand
- 6872.....Cymbal stands (2)
- 6080.....Drum sticks
- 6095.....Wire brushes

Cymbals not included.



CONCERT TOM TOMS & BONGOS



AUGUSTAR CONCERT TOM TOMS

SUPERSTAR 9600 Series

9663 9" x 13"	9665 12" x 15"
9664 10" x 14"	9666 14" x 16"
6899 Stand	6899 Stand
Low-Pitch outfit NO.9669	

FIBRESTAR 9200 Series

9256 5 1/2" x 6"	9260 6 1/2" x 10"
9258 5 1/2" x 8"	9262 8" x 12"
6899 Stand	6899 Stand
Hi-Pitch outfit NO.9268	
9263 9" x 13"	9265 12" x 15"
9264 10" x 14"	9266 14" x 16"
6899 Stand	6899 Stand
Low-Pitch outfit NO.9269	
Complete 8-pcs outfit NO.9270	

IMPERIALSTAR 8500 Series

8556 5 1/2" x 6"	8560 6 1/2" x 10"
8558 5 1/2" x 8"	8562 8" x 12"
6899 Stand	6899 Stand
Hi-Pitch outfit NO.8568	
8563 9" x 13"	8565 12" x 15"
8564 10" x 14"	8566 14" x 16"
6899 Stand	6899 Stand
Low-Pitch outfit NO.8569	
Complete 8-pcs outfit NO.8570	

TAMA AUGUSTAR CONCERT TOM TOMS & STANDS



CONCERT TOM TOM STANDS

The new Tama All-Angle concert tom tom stand allows concert tom toms to be interchanged and mixed with regular tom toms. Both tom toms feature the same bracket, giving you complete freedom of set-up.

- NO.6899 Fully adjustable to usable 55" height.
- NO.6899ST Allows tom toms to be adjusted to approximately the height of floor tom toms.



BONGOS, STANDS & HOLDERS

- CONCERT STICK BONGOS
NO.8502 with C.S. heads.
- FIBRE-SKIN BONGOS
NO.8504 with fibre-skin heads.
- BONGO STAND
NO.6843 fully adjustable.
- HOOP MOUNT BONGO HOLDER
NO.50-L
- TUBE MOUNT BONGO HOLDER
NO.60-L

IMPERIALSTAR MARS 4 OUTFIT NO.8904

- 8522 14"×22" Bass drum
- 6681 Single tom tom holder
- 8005 5"×14" Metal snare drum
- 8513 9"×13" Tom tom
- 8536 16"×16" Floor tom tom
- 6755.....Drum pedal
- 6890.....Snare drum stand
- 6895.....Hi-hat stand
- 6892.....Cymbal stands (2)
- 6082.....Drum sticks

Cymbals not included.



IMPERIALSTAR MARS 5A OUTFIT NO.8935

- 8522 14"×22" Bass drum
- 6682 Double tom tom Holder
- 8005 5"×14" Metal snare drum
- 8512 8"×12" Tom tom
- 8513 9"×13" Tom tom
- 8536 16"×16" Floor tom tom
- 6755.....Drum pedal
- 6890.....Snare drum stand
- 6895.....Hi-hat stand
- 6892.....Cymbal stands (2)
- 6082.....Drum sticks

Cymbals not included.



IMPERIALSTAR MARS 6 OUTFIT NO.8936

- 8522 14"×22" Bass drum
- 6682-3T Triple tom tom holder
- 8005 5"×14" Metal snare drum
- 8512 8"×12" Tom tom
- 8513 9"×13" Tom tom
- 8514 10"×14" Tom tom
- 8536 16"×16" Floor tom tom
- 6755.....Drum pedal
- 6890.....Snare drum stand
- 6895.....Hi-hat stand
- 6892.....Cymbal stands (2)
- 6082.....Drum sticks

Cymbals not included.



IMPERIALSTAR MERCURY OUTFIT

HI-BEAT DRUM PEDAL NO.6740
Adjustable beater stroke angle.
Easy spring adjustment.
Built-in anchor.
Positive beater clamp.
Heavy duty cam strap.

METAL SNARE DRUM NO.8045
Seamless metal shell.
TAMA PC die-cast hoops.
One-touch tone control.
TAMA ambassador drum heads.
CL compound lever strainer.

MERCURY DRUM STANDS
Single legs with wide-stance tripod base.
Excellent stability and light weight.

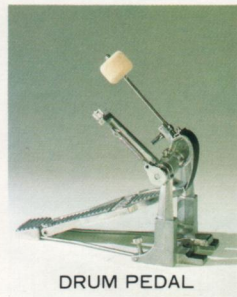
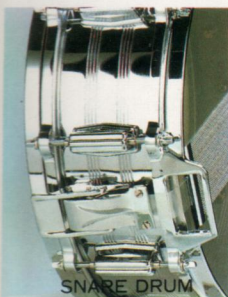

IMPERIALSTAR MERCURY 4 OUTFIT NO.8704

- 8522 14"×22" Bass drum
- 6681 Single tom tom holder
- 8045 5"×14" Metal snare drum
- 8513 9"×13" Tom tom
- 8536 16"×16" Floor tom tom
- 6740.....Drum pedal
- 6870.....Snare drum stand
- 6875.....Hi-hat stand
- 6872.....Cymbal stands (2)
- 6080.....Drum sticks
- 6095.....Wire brushes

Finish shown: M-54 Metallic Gold.
Cymbals not included.



IMPERIALSTAR MERCURY 5 OUTFIT NO.8705

- 8522 14"×22" Bass drum
- 6682 Double tom tom holder
- 8045 5"×14" Metal snare drum
- 8512 8"×12" Tom tom
- 8513 9"×13" Tom tom
- 8536 16"×16" Floor tom tom
- 6740.....Drum pedal
- 6870.....Snare drum stand
- 6875.....Hi-hat stand
- 6872.....Cymbal stands (2)
- 6080.....Drum sticks
- 6095.....Wire brushes

Cymbals not included.



CONCERT TOM TOMS & BONGOS



AUGUSTAR CONCERT TOM TOMS

SUPERSTAR 9600 Series

9663 9" x 13"	9665 12" x 15"
9664 10" x 14"	9666 14" x 16"
6899 Stand	6899 Stand
Low-Pitch outfit NO.9669	

FIBRESTAR 9200 Series

9256 5 1/2" x 6"	9260 6 1/2" x 10"
9258 5 1/2" x 8"	9262 8" x 12"
6899 Stand	6899 Stand
Hi-Pitch outfit NO.9268	
9263 9" x 13"	9265 12" x 15"
9264 10" x 14"	9266 14" x 16"
6899 Stand	6899 Stand
Low-Pitch outfit NO.9269	
Complete 8-pcs outfit NO.9270	

IMPERIALSTAR 8500 Series

8556 5 1/2" x 6"	8560 6 1/2" x 10"
8558 5 1/2" x 8"	8562 8" x 12"
6899 Stand	6899 Stand
Hi-Pitch outfit NO.8568	
8563 9" x 13"	8565 12" x 15"
8564 10" x 14"	8566 14" x 16"
6899 Stand	6899 Stand
Low-Pitch outfit NO.8569	
Complete 8-pcs outfit NO.8570	

TAMA AUGUSTAR CONCERT TOM TOMS & STANDS



CONCERT TOM TOM STANDS

The new Tama All-Angle concert tom tom stand allows concert tom toms to be interchanged and mixed with regular tom toms. Both tom toms feature the same bracket, giving you complete freedom of set-up.

- NO.6899 Fully adjustable to usable 55" height.
- NO.6899ST Allows tom toms to be adjusted to approximately the height of floor tom toms.



BONGOS, STANDS & HOLDERS

- CONCERT STICK BONGOS NO.8502 with C.S. heads.
- FIBRE-SKIN BONGOS NO.8504 with fibre-skin heads.
- BONGO STAND NO.6843 fully adjustable.
- HOOP MOUNT BONGO HOLDER NO.50-L
- TUBE MOUNT BONGO HOLDER NO.60-L



GEORGE BENSON GROUP

《DRUMS》 DENNIS DAVIS



① SEAMLESS METAL SHELL

Tama seamless snare drum shells are constructed by a special process which assures a perfectly round shell every time. Your drum heads will fit perfectly, and will be easier to tune and keep in tune. The uniform thickness of Tama seamless snare drum shells gives you a consistency of tone you'll have to hear to believe. Tama seamless shell snare drums have a warm, fat sound that won't break up or choke even in the fastest, loudest rolls. The inner flanges of the shell are set at a perfect 45° angle for added strength and increased acoustic response when playing near the edge of the head. And speaking of acoustic response, the shell edges are formed with a mere 2 millimeter radius giving the heads unlimited freedom of vibration.

② TAMA PC DIE-CAST HOOPS

The perfect complement for the Tama seamless shell is the Tama PC die-cast hoop. Tama PC hoops have many advantages over conventional hoops. First of all, the Tama PC hoop is die-cast to a perfect circle to assure a perfect fit to both the drum head and the shell. Tama PC hoops won't flex the way conventional hoops will, so tuning and head tension is more consistent and accurate all the way around. And because Tama PC hoops are solid and warp-free, rim shots are bigger, crisper and cleaner than ever before. All Tama PC hoops feature 10 lug tension for even, accurate and precise tuning.

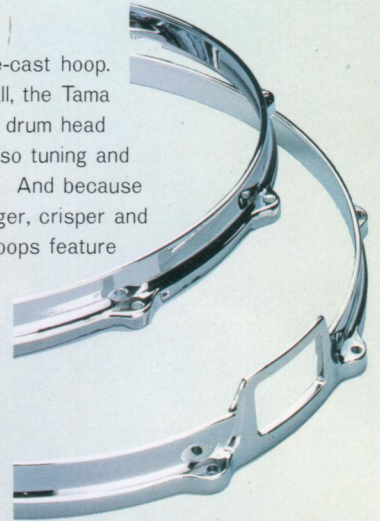

③ ONE-TOUCH TONE CONTROL

The Tama One-Touch tone control is one of our exclusive features that drummers rave about. The exact amount of tone control can be preset and brought in and out on cue-precise and accurate every time. You won't ever again have to waste time searching for that "just right" sound.

④ CHOICE OF SNARE STRAINERS

No snare strainer can satisfy the needs of every drummer, so Tama offers you three specially engineered snare strainers from which to choose. The Tama **KG** parallel-Action strainer offers the finest adjustment over the widest range, with separate snare tension and head pressure adjustments. Snare operation is exactly parallel to the head surface and there are no strings or tabs to stretch or break. The Tama **CL** Compound Lever strainer is a rugged die cast unit that provides accurate fine tuning and quick, positive operation particularly when using extra-wide snares. The Tama **SS** Compact Lever strainer puts the tension adjustment and on/off lever on the same side of the drum. The Tama SS strainer is a simple and functional design that will fit the needs of most drummers.

⑤ TAMA AMBASSADOR DRUM HEADS

TAMA ambassador snare and batter heads are the finest and most sensitive heads available today. All Tama snare drums feature special design ambassador heads for the best and most consistent response possible.



TAMA SNARE DRUMS



WOOD SHELL

KG Series NO.9605 5" x 14"
 NO.9606 6 1/2" x 14"
KG parallel action strainer.

SS Series NO.9675 5" x 14"
 NO.9676 6 1/2" x 14"
SS lever strainer.

Batter : Cana-sonic.
 Snare : Tama Ambassador.
 PC die-cast hoops.
 One-touch tone control.

Available in
 Natural Maple finish.
 Natural Walnut finish.

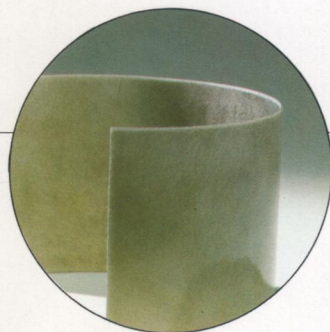
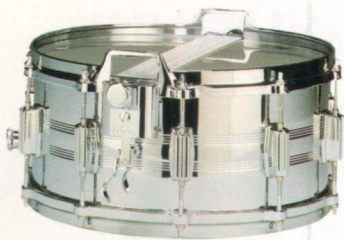

METAL SHELL

KG Series NO.8005 5" x 14"
 NO.8006 6 1/2" x 14"
 TAMA ambassador heads.
KG parallel action strainer.
 PC die-cast hoops.
 One-touch tone control.
 Seamless metal shell.

CL Series NO.8045 5" x 14"
 NO.8046 6 1/2" x 14"
 TAMA ambassador heads.
CL compound lever strainer.
 PC die-cast hoops.
 One-touch tone control.
 Seamless metal shell.

SS Series NO.8075 5" x 14"
 TAMA ambassador heads.
SS lever strainer.
 PC die-cast hoops.
 One-touch tone control.
 Seamless metal shell.



FIBREGLASS SHELL

KG Series NO.9205 5" x 14"
 NO.9206 6 1/2" x 14"
KG parallel action strainer.

CL Series NO.9245 5" x 14"
CL compound lever strainer.

SS Series NO.9275 5" x 14"
SS lever strainer.

Batter : Cana-sonic
 Snare : Tama ambassador
 PC die-cast hoops
 One-touch tone control.

Available in
 M-58 Platina
 M-55 Midnight Blue
 M-53 Metallic White



**TAMA KING-BEAT BASS DRUM PEDAL
NO.6755**

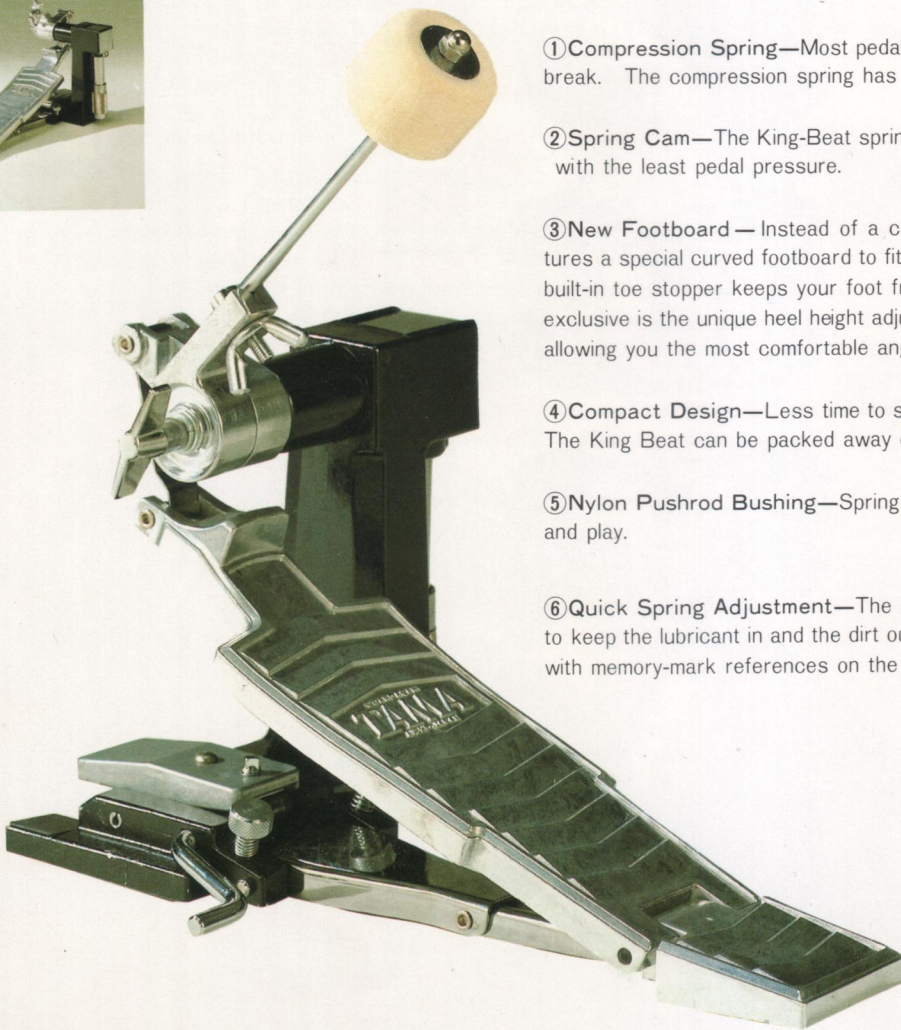
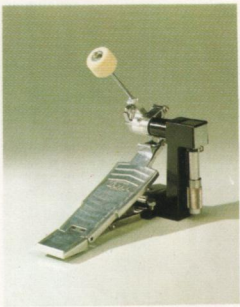

① **Compression Spring**—Most pedals employ an expansion spring which can stretch and break. The compression spring has excellent durability and very smooth action.

② **Spring Cam**—The King-Beat spring is cam actuated, giving a quick and positive stroke with the least pedal pressure.

③ **New Footboard**—Instead of a conventional flat footboard, the Tama King Beat features a special curved footboard to fit the natural curvature of the sole of your shoe. The built-in toe stopper keeps your foot from slipping for more positive action. Another Tama exclusive is the unique heel height adjustment completely independent of other adjustments, allowing you the most comfortable angle.

④ **Compact Design**—Less time to set up and break down with the one-touch rim clamp. The King Beat can be packed away easily without extensive breakdown.

⑤ **Nylon Pushrod Bushing**—Spring pushrod is seated in a nylon bushing eliminating noise and play.

⑥ **Quick Spring Adjustment**—The compression spring is contained in a sealed housing to keep the lubricant in and the dirt out. The simple external adjustment is quick and easy with memory-mark references on the spring housing.

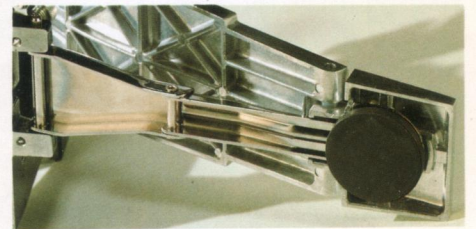

**HI-BEAT BASS DRUM PEDAL
NO.6740**

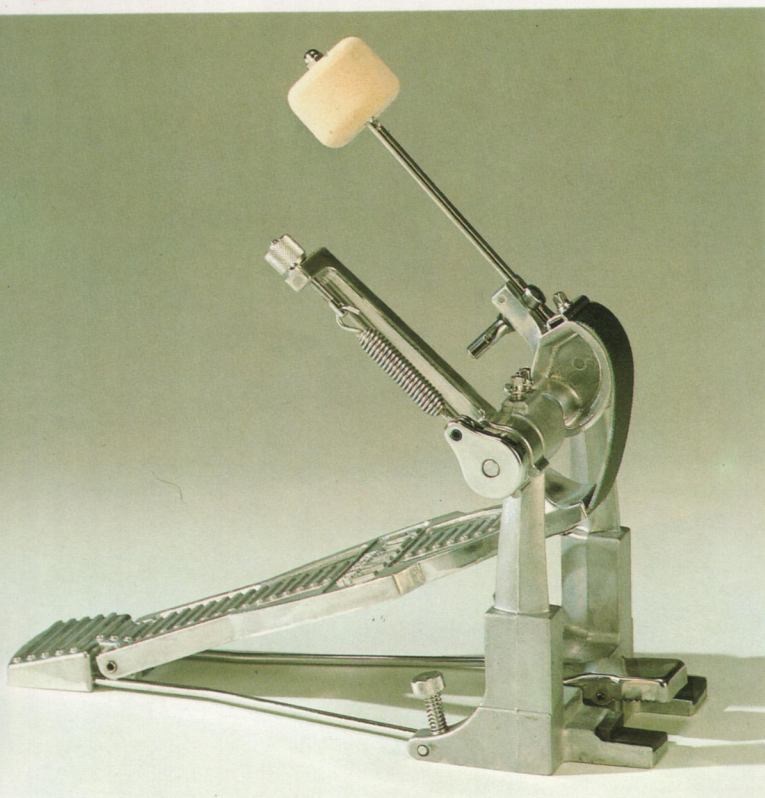

① **Easy Spring Adjustment**—The spring is easily adjusted and the positive lock keeps it where you set it.

② **Adjustable Beater Stroke Angle**—Independent of spring tension for any playing style.

③ **Built-in Anchors**—Help stop bass drum creep, Fully adjustable.

④ **Positive Beater Clamp**—Holds the beater without slipping or marring and weakening the beater shaft. Adjustable length for different bass drum sizes.

⑤ **Heavy Duty Cam Strap**—Specially processed and woven industrial nylon strap is many times stronger than leather. For smooth transfer of power from footboard to beater cam.

SNARE DRUM STANDS

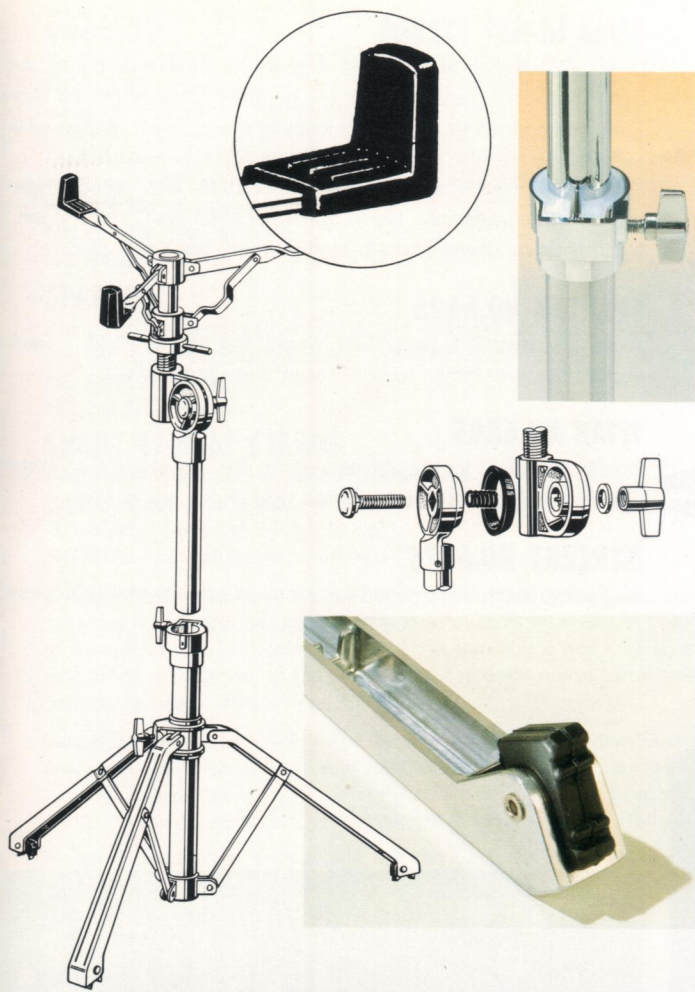

TAMA SNARE STANDS

All Tama snare stands feature the Tama exclusive nylon bushing clamp for smooth positive height adjustment and long service. Fully adjustable tripod legs for stability and versatility. Tama exclusive brake drum angle adjustment lets you set the angle precisely where you want it. Unique brake drum design (pat. pend.) locks perfectly with fingertip pressure. Molded in-place rubber tips won't pull off. Won't mar snare drum and can't rattle.

SPARTAN NO.6920

Aluminum die-cast legs for light weight and high strength. Two-way convertible tips with either rubber stoppers or stage spikes.

TITAN NO.6890

Double steel legs for the utmost stability and the widest leg span in the industry. The fan-shaped rubber tip provides rigid grip in any position.

MERCURY NO.6870

Single leg, wide-stance tripod for excellent stability and light weight.



NO.6920



NO.6890



NO.6870

TAMA HI-HAT STANDS

TAMA HI-HAT STANDS

Direct Pull Action—Smooth and noiseless Independent Spring Adjustment—Quick and easy, Separate from rod housing. New, Improved Cymbal Seat—Easy and positive tilt adjustment locks in place. Special tapered interior for easy set-up.

The Solid Tama Clutch features a special 15° lock screw angle for positive, no-slip adjustment. Nylon cymbal lock nut won't come loose. Nylon Bushing Clamp—Smooth, positive, quiet, won't mar shaft.

SPARTAN NO.6925

Aluminum die-cast legs for light weight and high strength. Two-way convertible tips with either rubber stoppers or stage spikes.

TITAN NO.6895

Double steel legs for the utmost stability and widest leg span in the industry. The fan-shaped rubber tip provides rigid grip in any position.

MERCURY NO.6875

Single leg, wide-stance tripod for excellent stability and light weight.

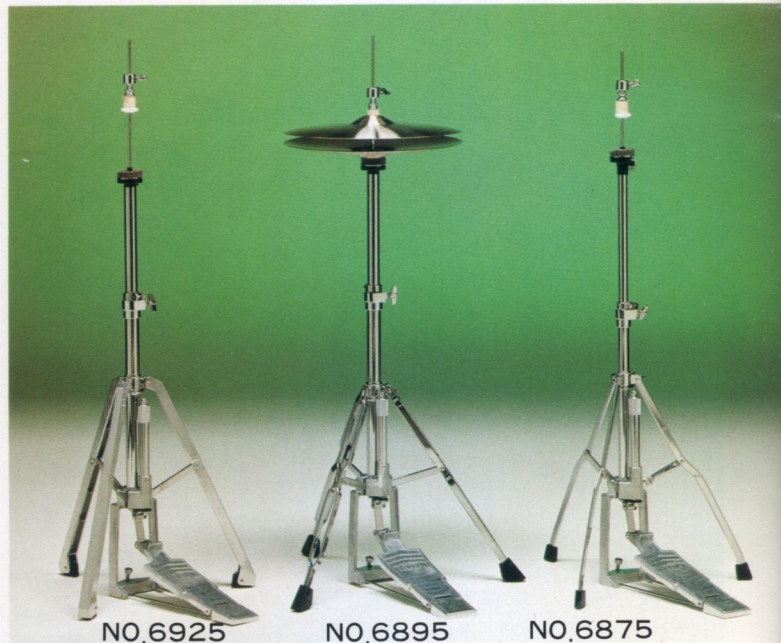

NO.6925

NO.6895

NO.6875



HI-HAT BRACE NO.6323

For double bass drummers who want a close-in hi-hat stand. Connects firmly to bass drum and hi-hat stand at any position.

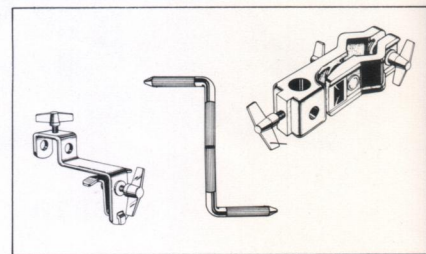

TAMA CYMBAL STANDS

MERCURY

Single leg, wide-stance tripod for excellent stability and light weight.
NO.6872 Straight.

TITAN

Double steel legs for the utmost stability and the widest leg span in the industry. The fan-shaped rubber tip provides rigid grip in any position.
NO.6892 Straight.
NO.6893 Double angle.
NO.6894 Boom.

SPARTAN

Aluminum die-cast legs for light weight and high strength. Two-way convertible tips with either rubber stoppers or stage spikes.
NO.6922 Straight.
NO.6924 Boom.

SHORT CYMBAL STANDS

Short cymbal stands for special applications. Smaller tripod legs fit into limited areas.
NO.6921 Spartan model, straight.
NO.6891 Titan model, straight.

Cymbal Mate—Made of a special nylon-fibreglass combination, the Cymbal Mate is the most versatile cymbal locknut-retainer available. Because of its hardness and durability, it won't fracture and it won't let your cymbals crack or wear out at the hole. Offset retainer converts for any cymbal holding need. (Pat. Pend.)

Nylon Bushing Clamp—Housed in a die-cast bracket, the Tama nylon bushing clamp holds telescoping stand sections firmly, without denting or marring. Designed to hold perfectly with only fingertip pressure. Your Tama stands will remain in perfect shape for years. (Pat. Pend.)

Boom Stands—The original and still the best, the Tama boom stand is often imitated, but never equalled. The special design ratchet clamp holds the boom arm securely at any angle. The new Tama cast iron counterweight helps balance heavy cymbals, yet folds compactly.

CYMBAL HOLDERS

NO.6630 Shell mount Cymbal Holder.
NO.6628 Hoop mount Cymbal Holder.

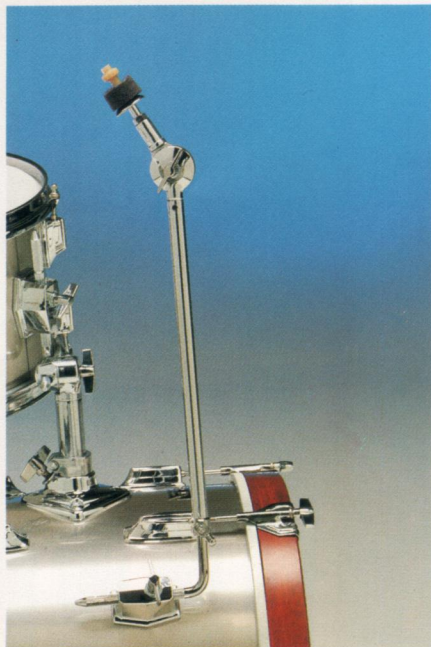
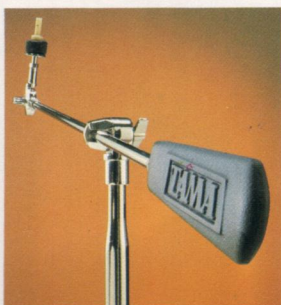
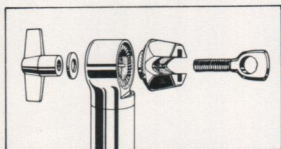
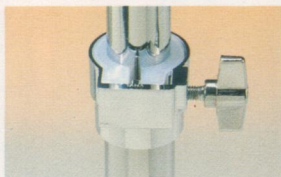
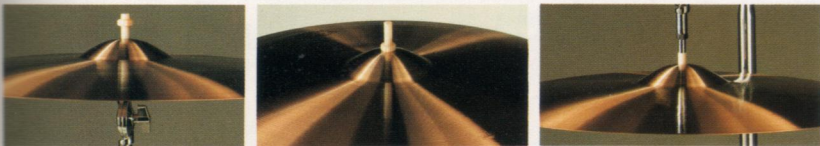

NO.6872

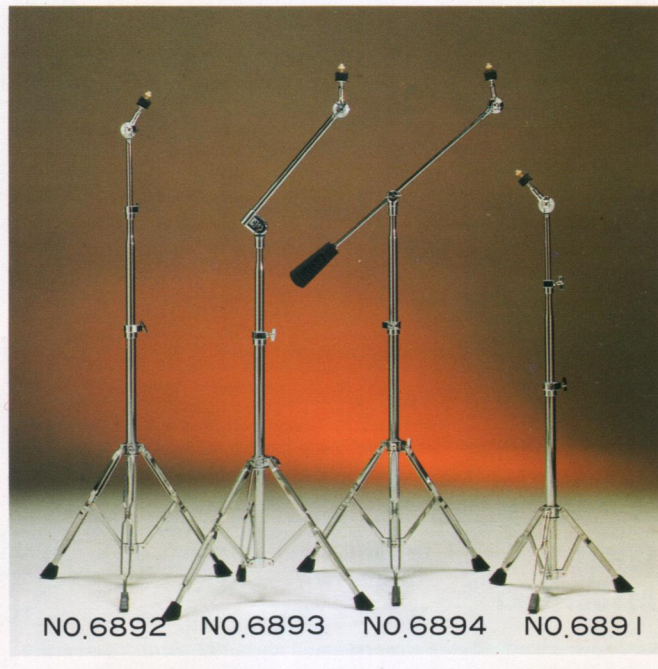
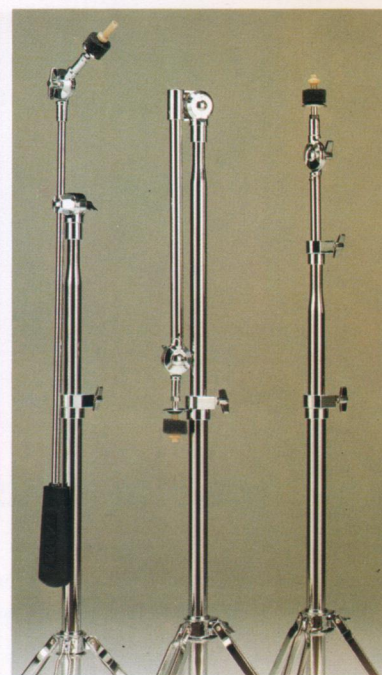

NO.6892 NO.6893 NO.6894 NO.6891



NO.6922 NO.6924 NO.6921

THRONES & STICKS



NO.6790

NO.6785

TAMA DRUM THRONES

Tama Titan Thrones use a double lock height adjustment for the best stability available. Thick foam cushion lets you play for hours without tiring. The Tama Titan Throne is becoming increasingly popular with keyboard players and guitarists, too.

- NO.6790 Titan Drum Throne.
- NO.6785 Mercury Drum Throne.



TAMA DRUM COVERS

BASS DRUMS

- NO.7188..... 14"×18"
- NO.7190..... 14"×20"
- NO.7192..... 14"×22"
- NO.7194..... 14"×24"
- NO.7196..... 14"×26"

FLOOR TOM TOMS

- NO.7174..... 14"×14"
- NO.7176..... 16"×16"
- NO.7178..... 16"×18"

TOM TOMS

- NO.7160.....6½"×10"
- NO.7162..... 8"×12"
- NO.7163..... 9"×13"
- NO.7164..... 10"×14"
- NO.7165..... 12"×15"
- NO.7166..... 14"×16"

SNARE DRUMS

- NO.7155..... 5"×14"
- NO.7156.....6½"×14"

CYMBAL BAGS

- NO.7180.....20"
- NO.7182.....22"
- NO.7184.....24"

TAMA DRUM STICKS

MODEL NO.	NO.6080 WOOD MODEL								NO.6082 WOOD MODEL						NO.6083	NO.6090 NYLON TIP MODEL					NO.6092 NYLON TIP				
	F	9A	5A	7A	3A	PRO 104	ROCK 105	ROCK 202	11A	5B	303	305B	2B	1S		2S	3S	9AN	5AN	7AN	ROCK 105N	ROCK 202N	5BN	2BN	2SN
LENGTH	405	380	405	390	400	405	410	405	405	405	410	405	405	425	425	430	380	405	390	410	405	405	405	405	425
% & INCH	16"	15"	16"	15½"	15¾"	16"	16¾"	16"	16"	16"	16¾"	16"	16"	16¾"	16¾"	17"	15"	16"	15¾"	16¾"	16"	16"	16"	16"	16¾"
THICKNESS	11.5	12.0	13.0	13.0	14.0	14.0	14.0	14.0	15.0	15.0	15.0	15.0	16.0	16.0	16.0	17.5	12.0	13.0	13.0	14.0	14.0	15.0	16.0	16.0	

STICKS ASSORTMENT

- NO.300N (NYLON TIP)
- TOTAL : 12 prs.
- 9AN.....3 prs.
- 5AN.....3 prs.
- 7AN.....3 prs.
- 5BN.....3 prs.

- NO.300W (WOOD)
- TOTAL : 12 prs.
- 9A.....3 prs.
- 5A.....3 prs.
- 7A.....3 prs.
- 5B.....3 prs.

STICK BAG NO.7170

DRUM BRUSHES NO.6095

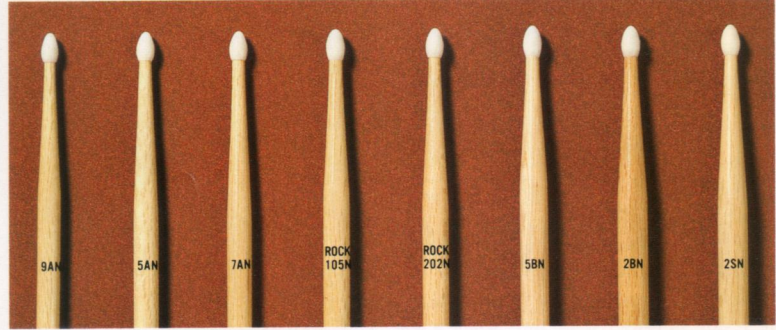
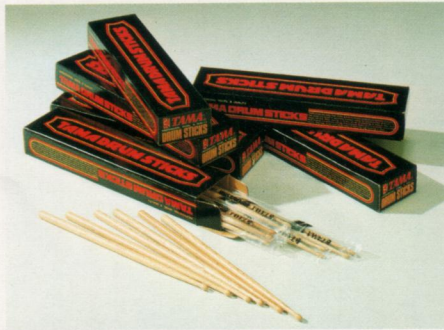

TOM TOM HOLDERS & STANDS

TAMA TOM TOM HOLDERS & STANDS



The Tama bass drum bracket will accept any Tama tom tom holder and is completely interchangeable throughout the line.

Tama double headed tom toms and concert tom toms both feature the same mounting bracket and are completely interchangeable. The three dimensional adjustment of Tama tom tom holders gives you a drum set up of any angle or position.

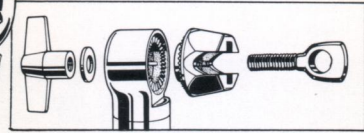

TAMA "KEY-LOCK"

A simple and effective way of giving your drum set a memory. A "Key-Lock" clamp fits on the tom tom holder and aligns with a keyway on the bass drum plate, giving you a preset height and angle.

Mini "Key-Locks" are installed on tom tom holder "L" rods and locate into keyways on the tom tom brackets. The Tama "Key-Lock" system is simple and effective, without cumbersome and expensive hardware. There are no parts that intrude into the drum shell and rob tone.

Tama tom tom holders also feature memory lines on rotating parts and interlocking teeth on the "L" rods for a rock solid mount.

TRIPLE TOM TOM ADAPTOR NO.67-L

Converts any Tama double tom tom holder or stand to a triple tom tom holder in seconds.

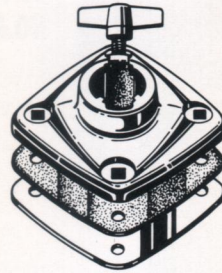
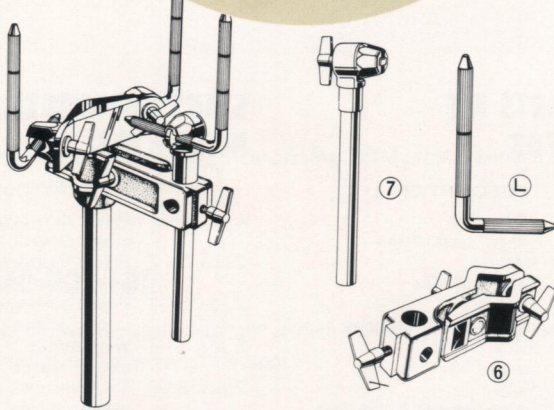

NO.668 I
Single tom tom holder, complete set.
NO.668 I-A

Single tom tom holder, less bass drum mount casting & bracket.



NO.6682
Double tom tom holder, complete set.
NO.6682-A

Double tom tom holder, less bass drum mount casting & brackets.



NO.6682-3T
Triple tom tom holder, complete set.
NO.67-L

Triple tom tom adaptor.



NO.6899
Double tom tom stand.
NO.6899ST
Short model tom tom stand.
NO.6899-3T
Triple tom tom stand.

SPURS & LEGS

NO.6580 Bass drum spurs, set.

NO.6575 Floor tom tom legs, set of 3.

Tama retractable bass drum spurs are heavy duty spurs at their best. They slant forward at 15° to positively insure against bass drum creep. The two-way convertible tips can be used as either rubber bumpers or stage spikes.



SHELL SUPPORTER

NO.6635

Playing with the front bass drum head removed can result in a slight ovaling of the shell after a period of time, particularly when large tom toms are mounted on the drum. You can stop this from happening by installing a Tama shell supporter. This adjustable supporter will bear the weight of the tom toms and will also keep a pillow or muffler in place.



DRUM PARTS KIT NO.DK-6703

DESCRIPTION

- 2 pcs. DK-1 "T" rods
usage: bass drums
- 10 pcs. DK-2 washers
usage: all rods
- 2 pcs. DK-3 Hooks
usage: bass drum rods
- 5 pcs. DK-4 Rods
usage: floor tom toms
- 10 pcs. DK-5 Rods
usage: snares & tom toms
- 2 pcs. DK-6 Lugs
usage: tom toms
- 1 pc. DK-7 Lug
usage: snare drums
- 1 pc. DK-8 Lug
usage: bass drums
- 10 pcs. DK-9 Lug nuts
usage: all lugs
- 10 pcs. DK-10 Nylon lug nut stoppers
usage: all lugs
- 10 pcs. DK-11 Mounting screws
usage: all lugs
- 2 pcs. DK-12 Rubber tips
usage: spurs & legs
- 2 pcs. DK-13 Thumb screws
usage: tom holders & spurs
- 5 pcs. DK-14 Plastic straps
usage: snappy snares
- 1 pc. DK-15 Eye bolt assembly
usage: mounting brackets
- 2 pcs. DK-16 Wing nuts
usage: tom tom holder & brackets
- 1 pc. DK-17 Eye bolt assembly
usage: tom tom holders
- 1 pc. DK-18 Hex wrench w/5 hex nuts
usage: tom tom holders & brackets (extra use)
- 2 pcs. DK-19 Snare butt plates w/screws
usage: snare butts
- 2 pcs. DK-20 Tone control dampers
usage: all drums

STAND PARTS KIT NO.SK-6701

DESCRIPTION

- 4 pcs. SK-1 Plastic bushings w/pin
usage: stands (big 28.6)
- 2 pcs. SK-2 Plastic bushings w/pin
usage: stands (medium 22.2)
- 2 pcs. SK-3 Plastic bushings w/pin
usage: stands (small 19.1)
- 3 pcs. SK-4 Wing screws
usage: stands
- 2 pcs. SK-5 Thumb screws
usage: stands
- 2 pcs. SK-6 Rubber tip assemblies
usage: stands (6920-6925)
- 2 pcs. SK-7 Rubber tips
usage: stands (6890-6895)
- 2 pcs. SK-8 Rubber tips
usage: stands (6870-6875)
- 2 pcs. SK-9 Felt washers
usage: hi-hat bottom seat
- 2 pcs. SK-10 Metal washers
usage: hi-hat bottom seat
- 2 pcs. SK-11 Bolt & nut assemblies
usage: hi-hat bottom seat
- 1 pc. SK-12 Hi-hat strrap assembly
usage: hi-hat stands
- 3 pcs. SK-13 Non-loose hex nuts
usage: hi-hat stands
- 1 pc. SK-14 Hi-hat clutch, complete
usage: hi-hat stands
- 2 pcs. SK-15 Non-loose plastic nuts
usage: hi-hat stands
- 1 pc. SK-16 Snare bolt & nut assembly
usage: snare stands
- 2 pcs. SK-17 Wing nuts
usage: stands & brackets
- 1 pc. SK-18 Cymbal tilter assembly
usage: cymbal stands
- 3 pcs. SK-19 Nylon treaded tube
usage: cymbal stands
- 1 pc. SK-20 Bolt & nut assembly
usage: cymbal stands

TAMA DRUMS REPLACEMENTS CATALOG

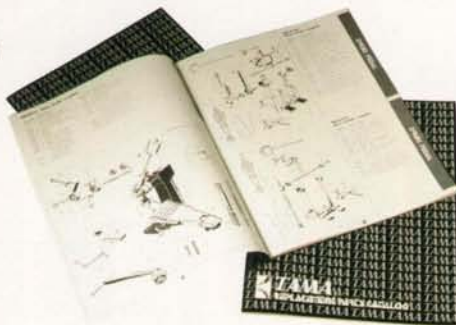

MIKE STANDS & HOLDERS



TAMA MIKE STANDS & HOLDERS

- 6 Multi-clamp
- 7 Ratchet arm
- A Mike holder w/counter weight.
- B Mike holder aluminum 60.
- C Mike holder aluminum 30.
- D Mike holder aluminum "L".
- 67-A 6 multi-clamp, 7 ratchet arm and A mike holder.
- 67-B 6 multi-clamp, 7 ratchet arm and B mike holder.
- 67-C 6 multi-clamp, 7 ratchet arm and C mike holder.
- 60-D 6 multi-clamp.....D mike holder.

Another new idea from Tama that opens up a world of versatility for your drum set. The Multi-Clamp line of accessories allows you to mount mikes, cymbals, tom toms, percussion accessories and music holders to your existing stands for a versatile and neat stage set up.

MIKE STAND NO.6000

Specially designed for drum miking. Double-leg TITAN tripod section is stable enough to hold several mikes.

MIKE STAND NO.6100

Designed for drummers, guitarists and other musicians. Superb stability and easy compact fold-down and transport.

